

ASSEMBLY INSTRUCTION

SKU CODE: N733LQQMV0808

INSTRUCTIONS DE MONTAGE

SKU CODE: N733LQQMV0808

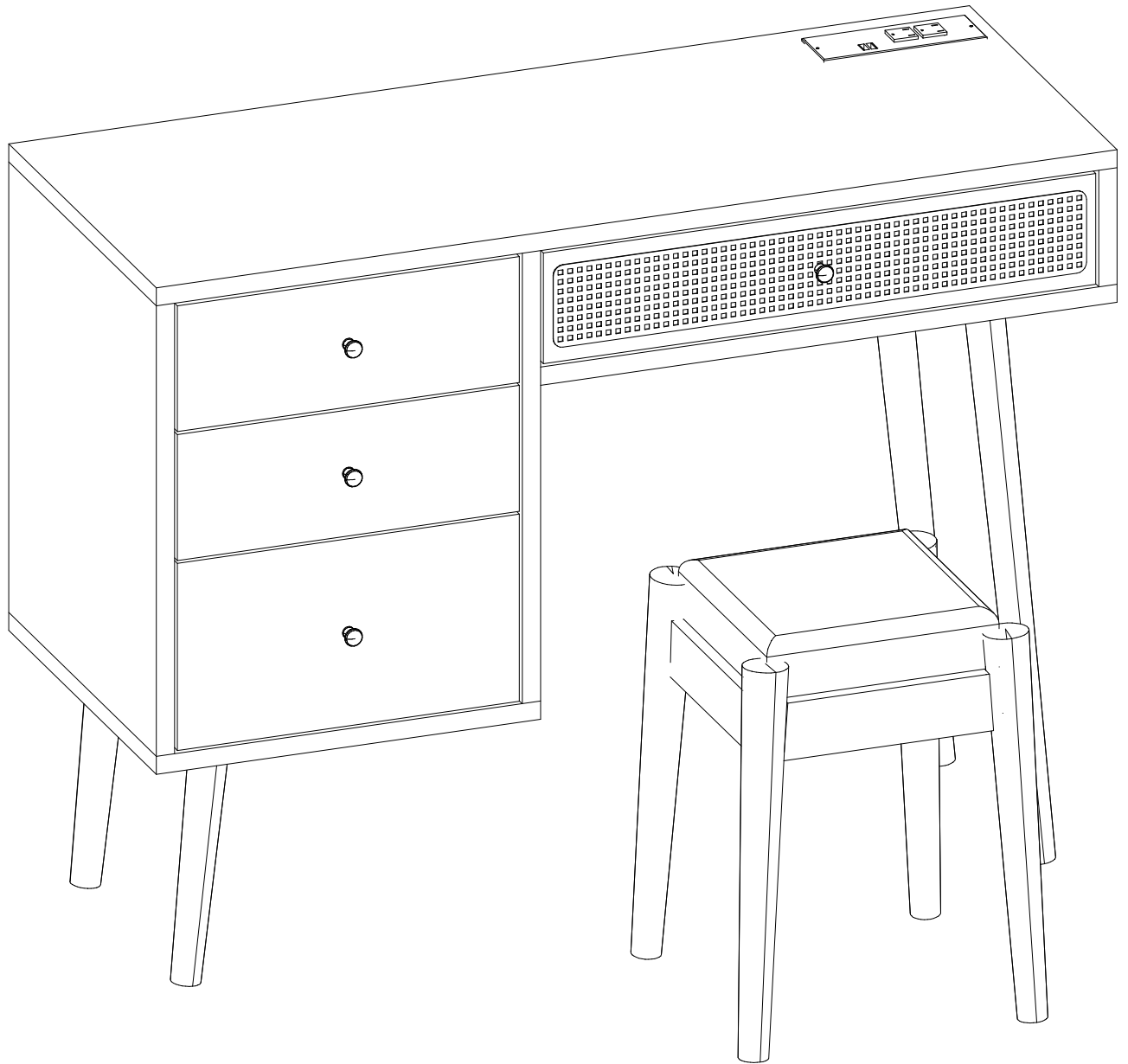



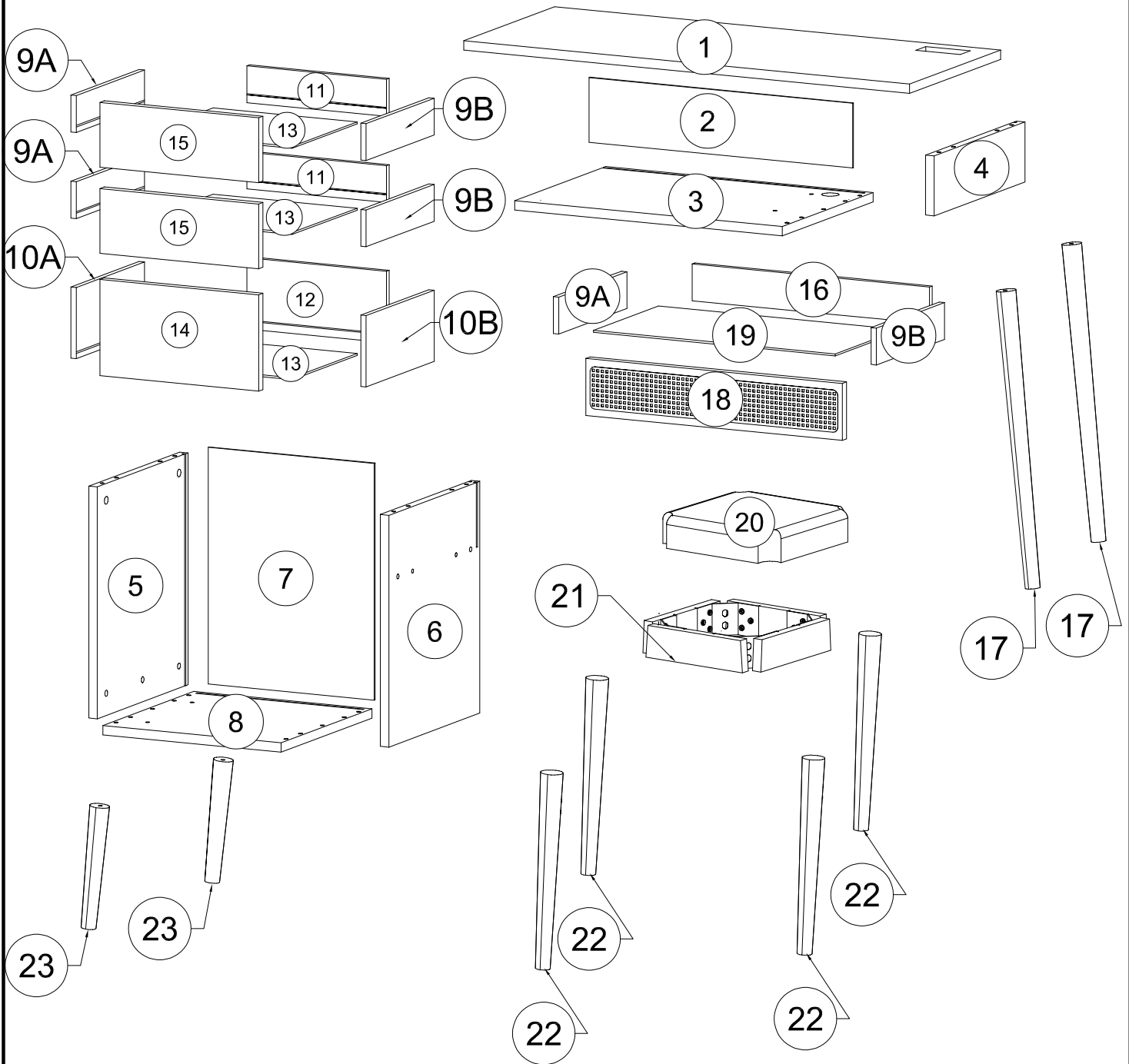

ASSEMBLY INSTRUCTION

INSTRUCTIONS DE MONTAGE

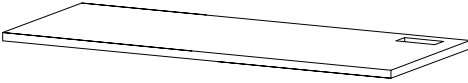

Part List N733LQQMV0808

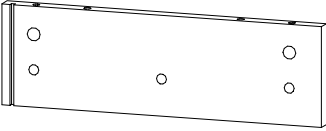
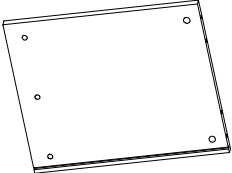
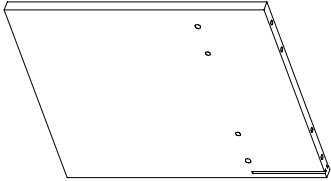
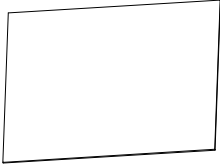
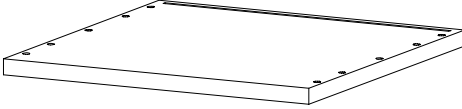
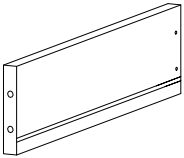
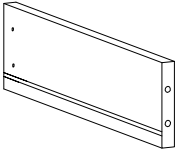
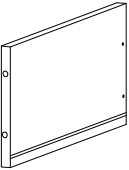
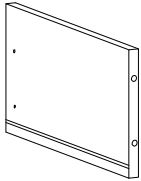
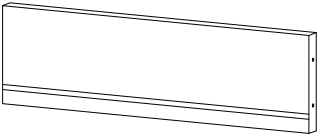
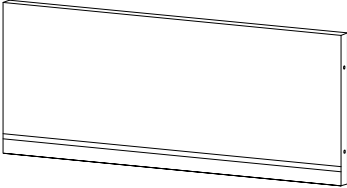
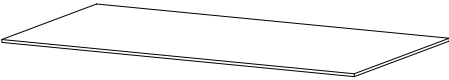
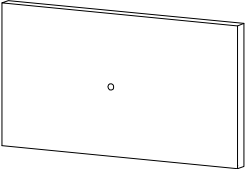
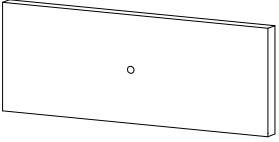
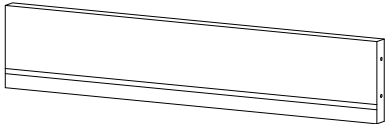
Liste des pièces N733LQQMV0808

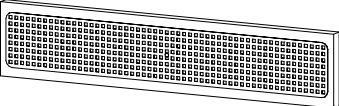
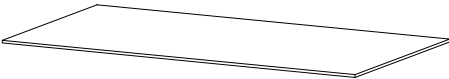
<p>1</p>  <p>WOODEN TABLE TOP - 1pc PLATEAU EN BOIS - 1pièces</p>	<p>2</p>  <p>PANEL - 1pc PANNEAU- 1pièces</p>	<p>3</p>  <p>BOTTOM OF THE TABLE - 1pc BAS DE TABLEAU - 1pièces</p>
<p>4</p>  <p>SIDE EDGE OF THE TABLE - 1pc BORD LATÉRAL DE LA TABLE - 1pièces</p>	<p>5</p>  <p>SIDE EDGE OF THE TABLE - 1pc BORD LATÉRAL DE LA TABLE - 1pièces</p>	<p>6</p>  <p>SIDE EDGE OF THE TABLE - 1pc BORD LATÉRAL DE LA TABLE - 1pièces</p>
<p>7</p>  <p>PANEL - 1pc PANNEAU- 1pièces</p>	<p>8</p>  <p>BOTTOM OF THE TABLE - 1pc BAS DE TABLEAU - 1pièces</p>	<p>9A</p>  <p>DRAWER-SIDE Panels-3pcs Panneaux CÔTÉ TIROIR-3pièces</p>
<p>9B</p>  <p>DRAWER-SIDE Panels-3pcs Panneaux CÔTÉ TIROIR-3pièces</p>	<p>10A</p>  <p>DRAWER-SIDE Panels-1pc Panneaux CÔTÉ TIROIR-1pièces</p>	<p>10B</p>  <p>DRAWER-SIDE Panels-1pc Panneaux CÔTÉ TIROIR-1pièces</p>
<p>11</p>  <p>DRAWER-Back Panels-2pcs Panneaux arrière de tiroir-2pièces</p>	<p>12</p>  <p>DRAWER-Back Panels-1pc Panneaux arrière de tiroir-1pièces</p>	<p>13</p>  <p>PANEL - 3pcs PANNEAU - 3pièces</p>
<p>14</p>  <p>DRAWER-FRONT Panels-1pc Panneaux AVANT DE TIROIR-1pièces</p>	<p>15</p>  <p>DRAWER-FRONT Panels-2pcs Panneaux AVANT DE TIROIR-2pièces</p>	<p>16</p>  <p>DRAWER-Back Panels-1pc Panneaux arrière de tiroir-1pièces</p>
<p>17</p>  <p>FOOT - 2pcs PIED - 2pièces</p>	<p>18</p>  <p>DRAWER-FRONT Panels-1pc Panneaux AVANT DE TIROIR-1pièces</p>	<p>19</p>  <p>PANEL - 1pc PANNEAU- 1pièces</p>

Part List N733LQQMV0808

Liste des pièces N733LQQMV0808

20

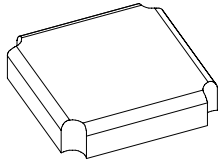

CUSHIONS - 1pc
COUSSINS - 1pièces

21

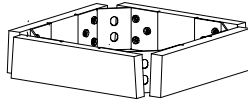

CHAIR FRAME - 1pc
CADRE DE CHAISE - 1pièces

22

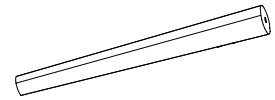

FOOT - 4pcs
PIED - 4pièces



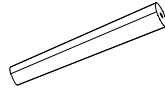





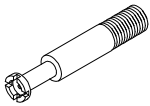

23

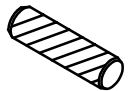
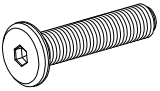

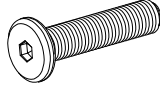
FOOT - 2pcs
PIED - 2pièces

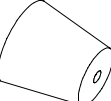
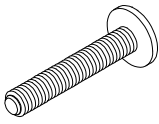
Hardware List N733LQQMV0808-BK

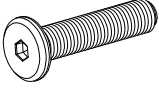
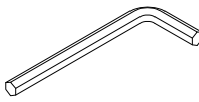
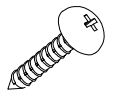
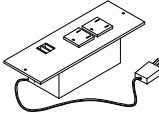
Liste du matériel N733LQQMV0808-BK

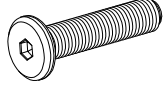
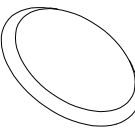

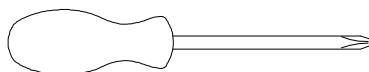
A  Link 1 - 8 pcs Lien 1 - 8 pièces	B  Link 2 - 8 pcs Lien 2 - 8 pièces	C  Ø8 x 30 mm Wood dowel 18pcs Cheville en bois Ø8 x 30 mm 18pièces
D  1/4" x 30mm Hex-Head bolts 4pcs Boulons à tête hexagonale 1/4" x 30 mm 4pièces	E  1/4" x 15mm Horizontal -Hole bolts 12pcs Boulons à trou horizontal 1/4" x 15 mm 12pièces	F  1/4" x 60mm Hex-Head bolts 9pcs Boulons à tête hexagonale 1/4" x 60 mm 9pièces
G  #4 x 30 mm Wood Screws 32pcs Vis à bois n° 4 x 30 mm 32pièces	H  CABINET DOOR HANDLES - 4pcs POIGNÉES DE PORTE D'ARMOIRE - 4pièces	R  M4 x 35mm Hex-Head bolts 4pcs Boulons à tête hexagonale M4 x 35 mm - 4pièces
J  #4 x 50 mm Wood Screws 4pcs Vis à bois n° 4 x 50 mm 4pièces	K  1/4" x 40mm Hex-Head bolts 8pcs Boulons à tête hexagonale 1/4" x 40 mm 8pièces	L  Allen Key 1pcs Clé Allen 1pièces
M  #4 x 15 mm Wood Screws 2pcs Vis à bois n° 4 x 15 mm 2pièces	N  USB Power Outlet 1 pc Prise de courant USB 1pièces	O  #4 x 35 mm Wood Screws 8pcs Vis à bois n° 4 x 35 mm 8pièces
P  1/4" x 50mm Hex-Head bolts 3pcs Boulons à tête hexagonale 1/4" x 50 mm 3pièces	I  Plastic button 8pcs Boutons en plastique 8pièces	



Assembly Tools Required (Not Included)
Outils d'assemblage requis (non inclus)

STEP 1: Following below illustration:

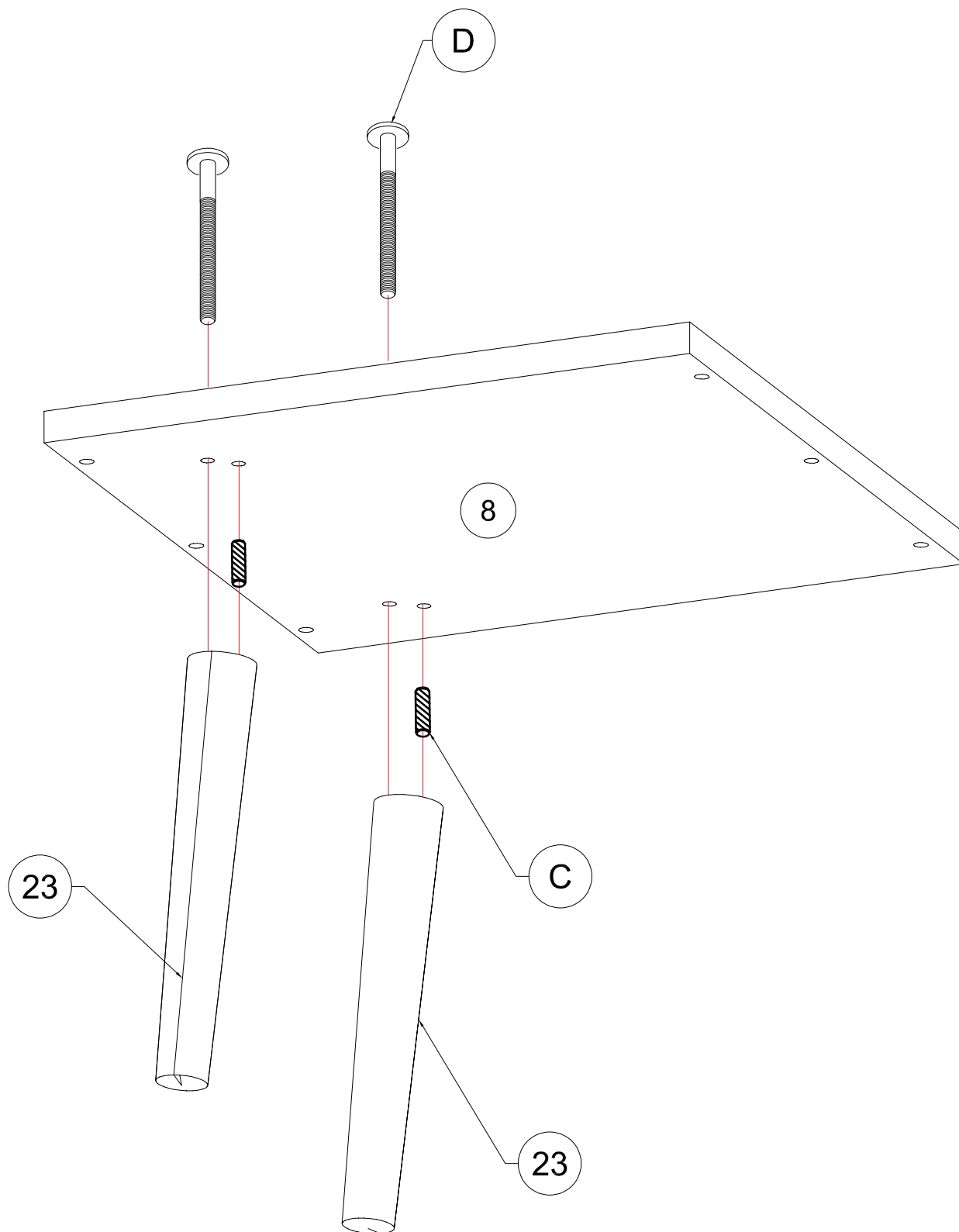

ÉTAPE 1 : Suivez l'illustration ci-dessous :

C 	D 
2pcs	2pcs



STEP 2: Following below illustration:

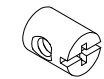
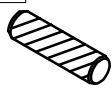

ÉTAPE 2 : Suivez l'illustration ci-dessous :

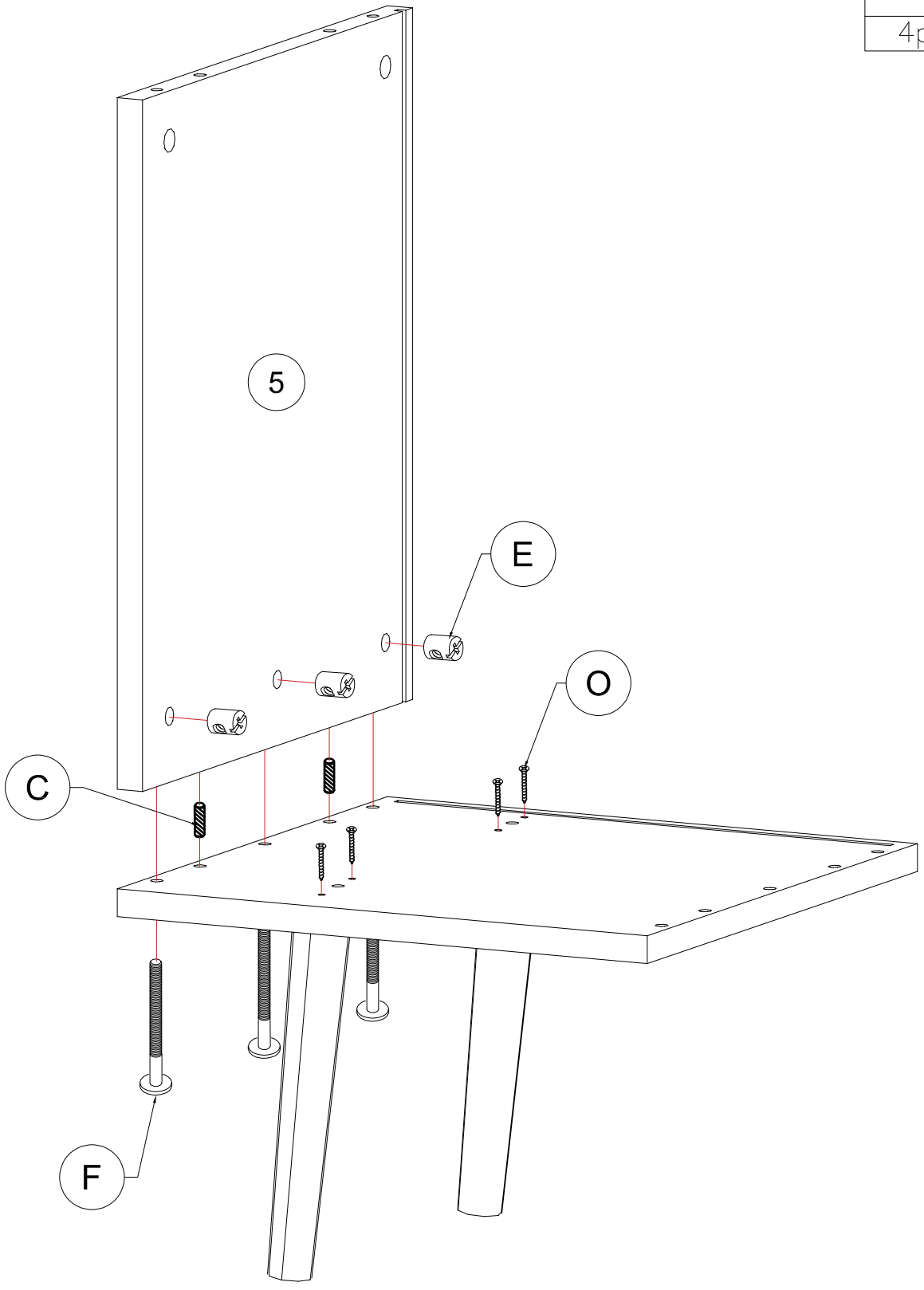
F 	E 	C 
3pcs	3pcs	2pcs
		O 
		4pcs



STEP 3: Following below illustration:

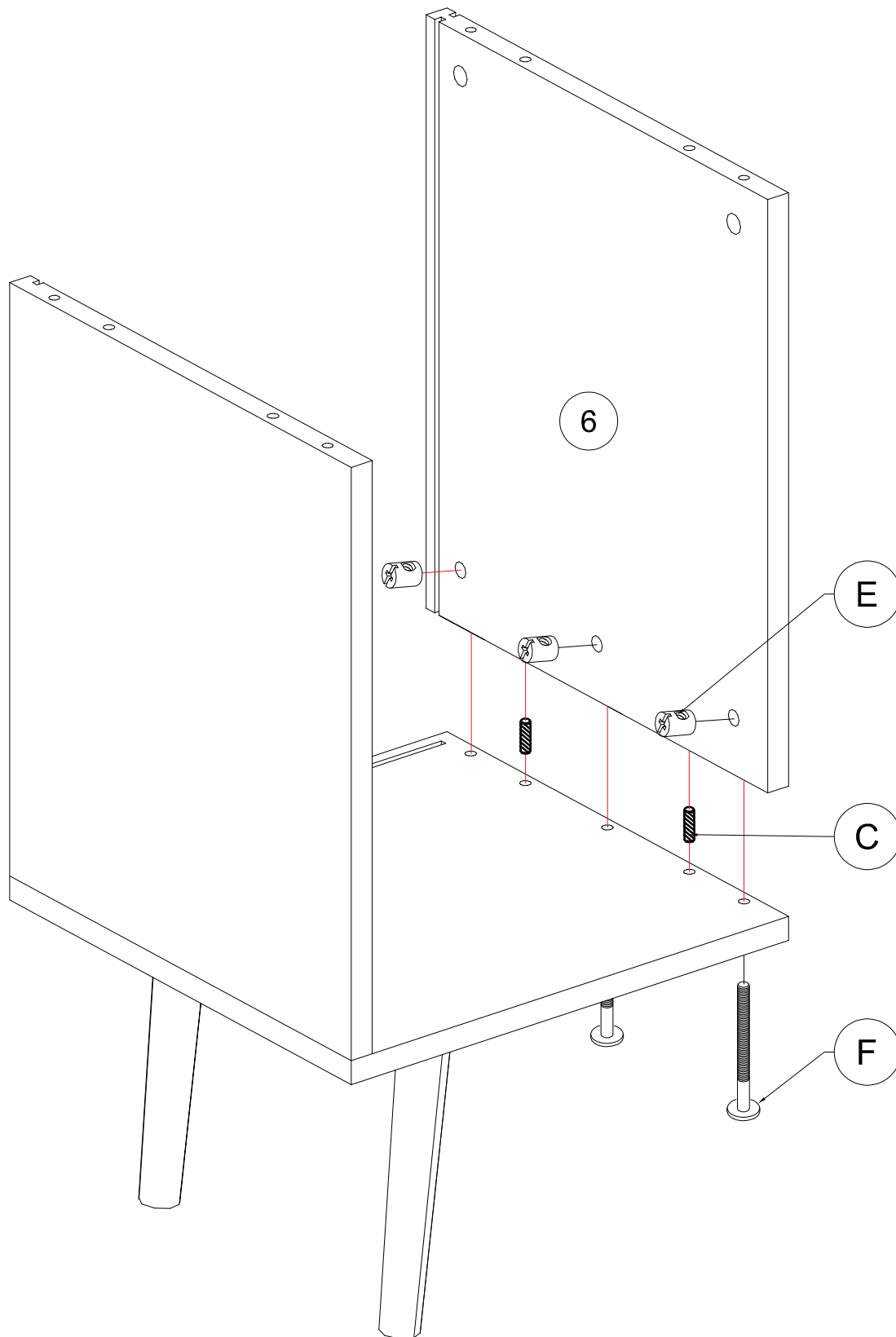

ÉTAPE 3 : Suivez l'illustration ci-dessous :

F	E	C
		
3pcs	3pcs	2pcs



STEP 4: Following below illustration:



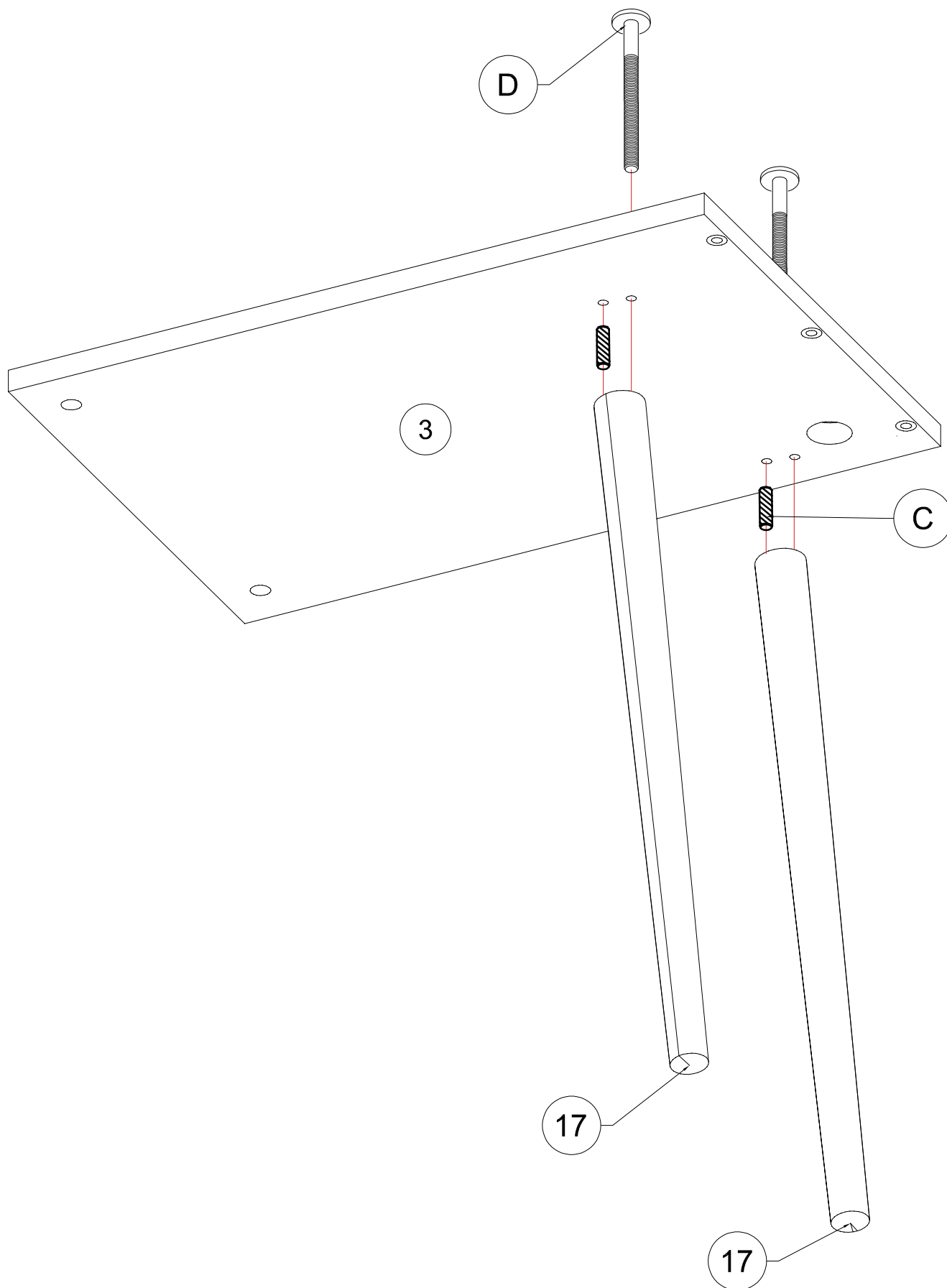

ÉTAPE 4 : Suivez l'illustration ci-dessous :

C 	D 
2pcs	2pcs



STEP 5: Following below illustration:

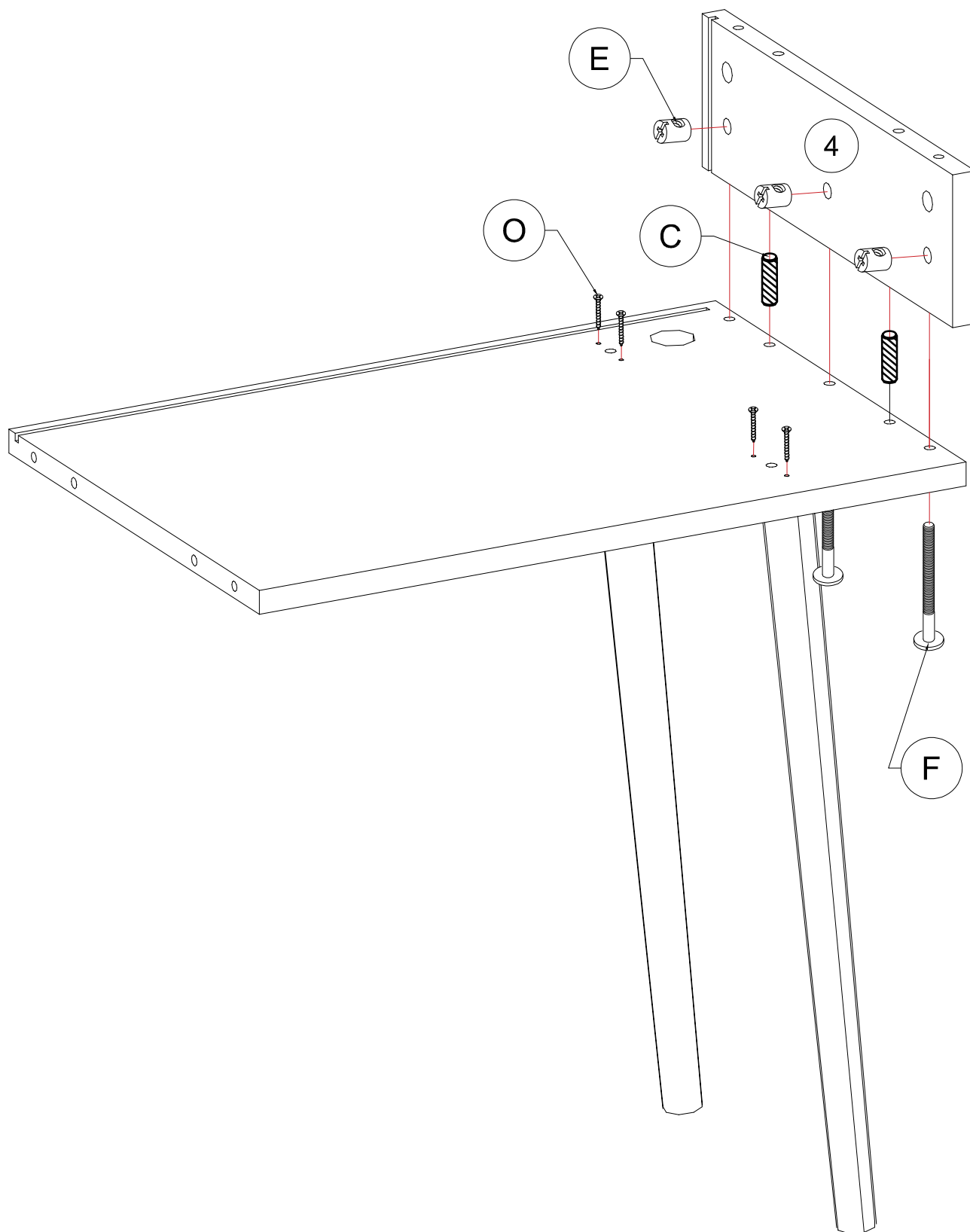

ÉTAPE 5 : Suivez l'illustration ci-dessous :

F 	E 	C 
3pcs	3pcs	2pcs
O 		
4pcs		

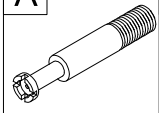

STEP 6: Following below illustration:

ÉTAPE 6 : Suivez l'illustration ci-dessous :

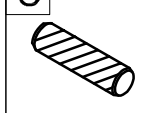
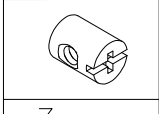
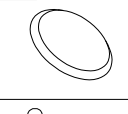
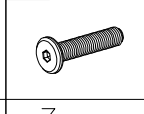
A 	B 	C 
2pcs	2pcs	2pcs
E 	I 	P 
3pcs	2pcs	3pcs

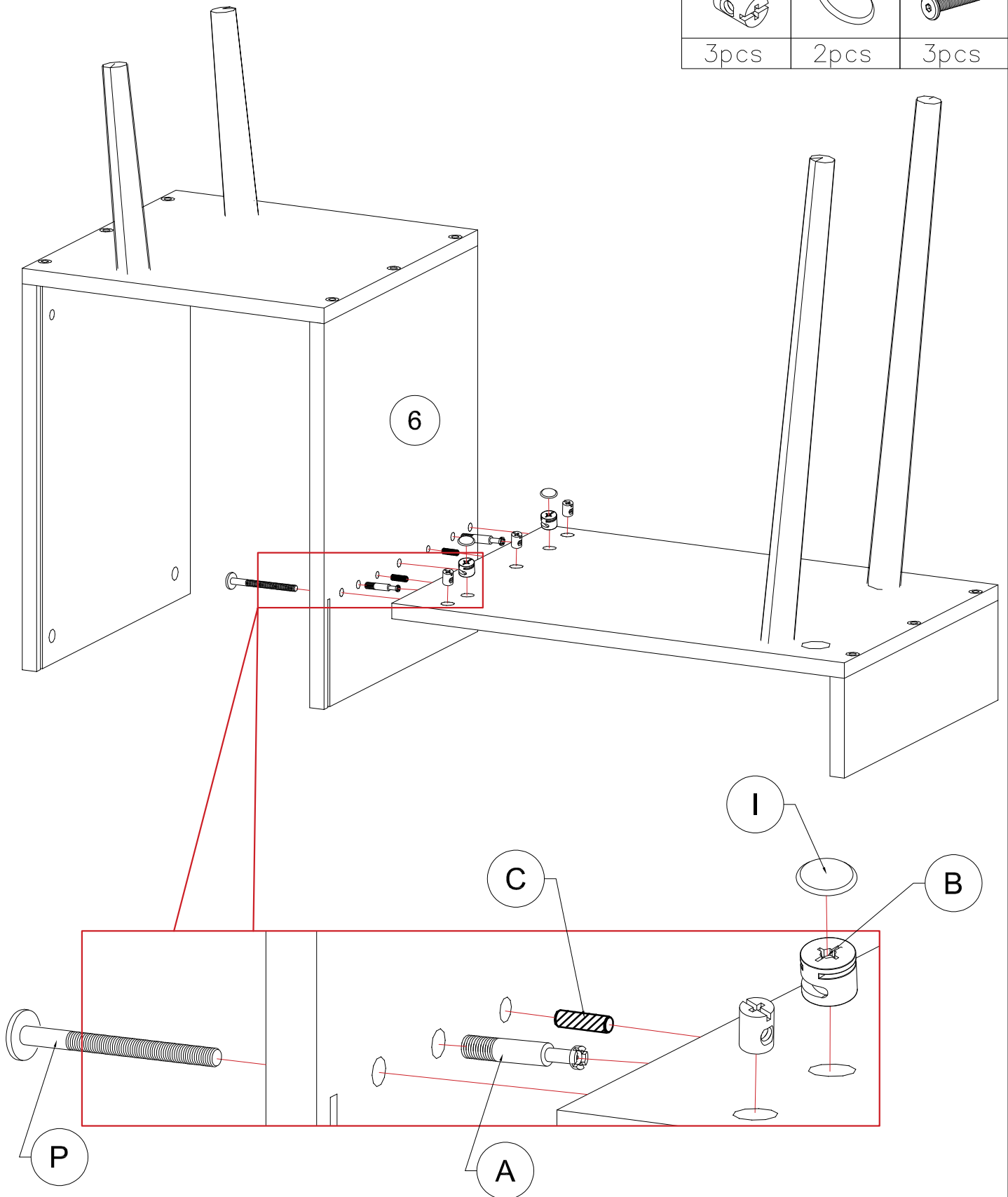



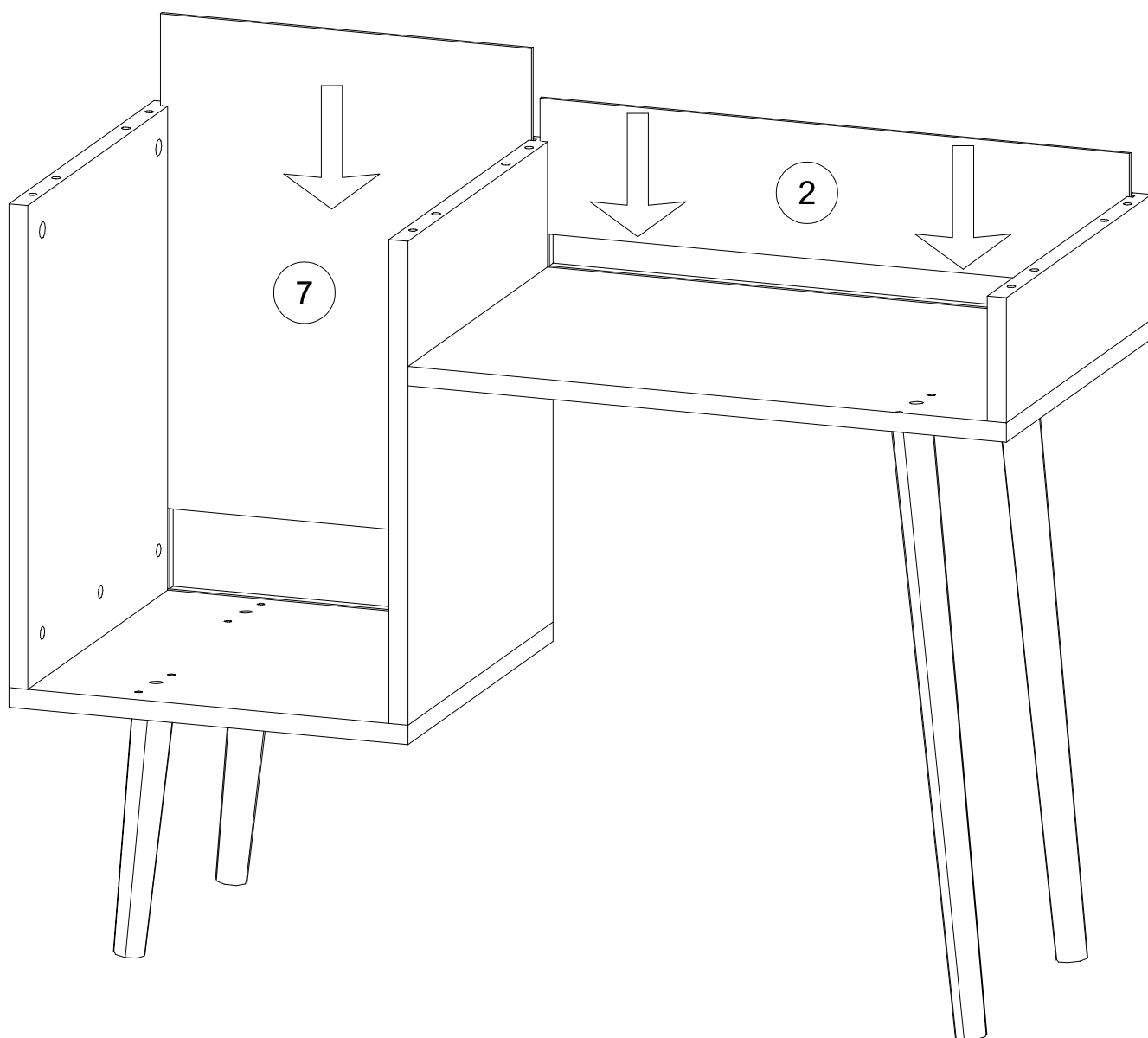

STEP 7: Following below illustration:

ÉTAPE 7 : Suivez l'illustration ci-dessous :

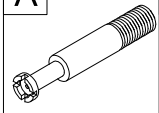

STEP 8: Following below illustration:

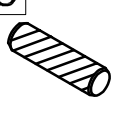
ÉTAPE 8 : Suivez l'illustration ci-dessous :

A 	B 	C 
6pcs	6pcs	6pcs
I 		
6pcs		

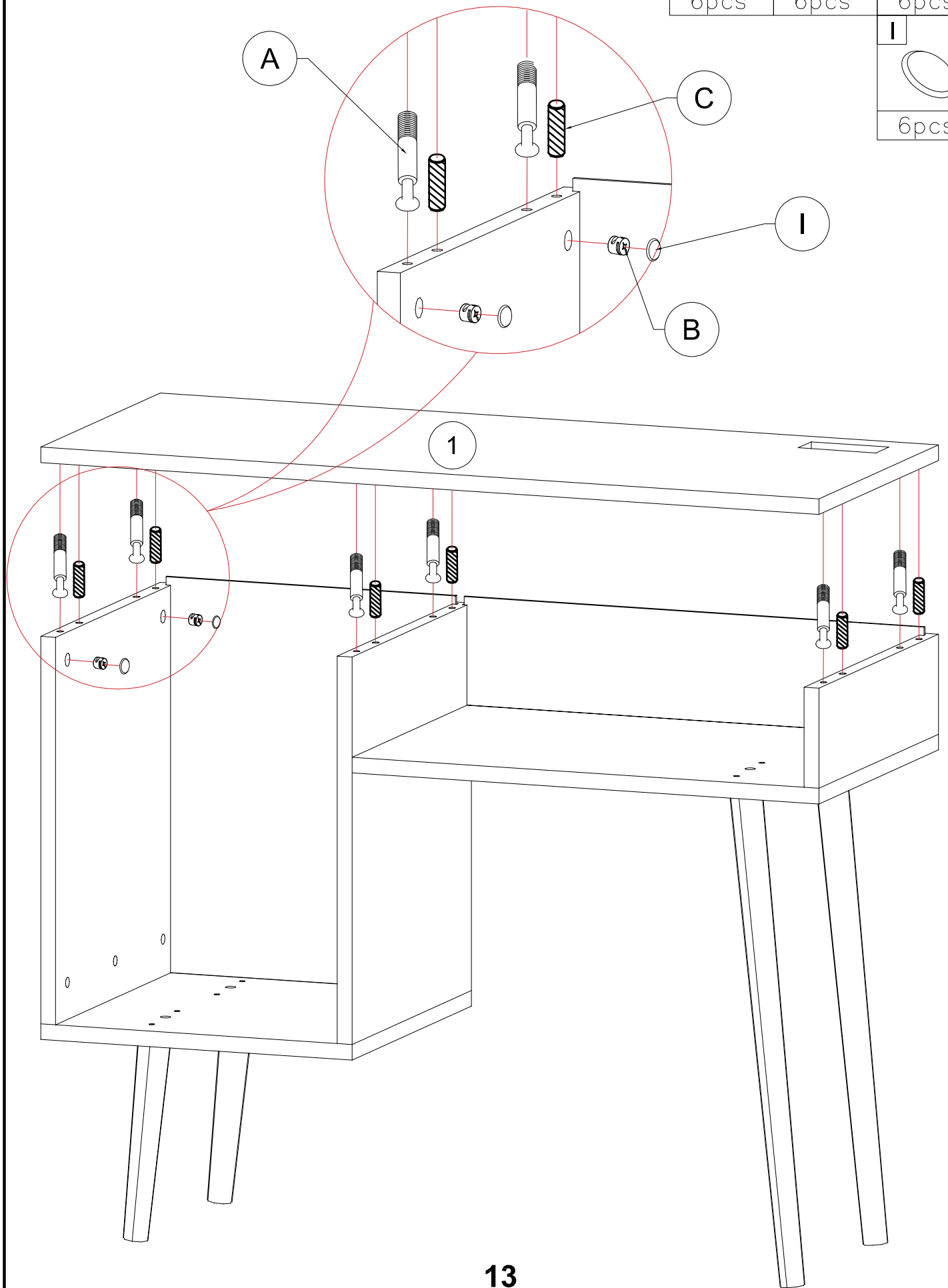

STEP 9.1: Following below illustration:

ÉTAPE 9.1 : Suivez l'illustration ci-dessous :

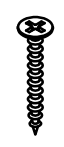
G	
8pcs	

X2

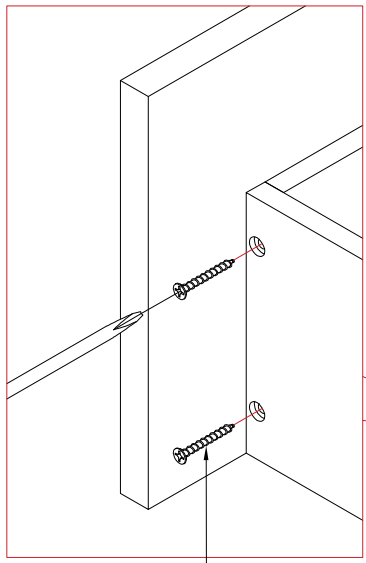

G

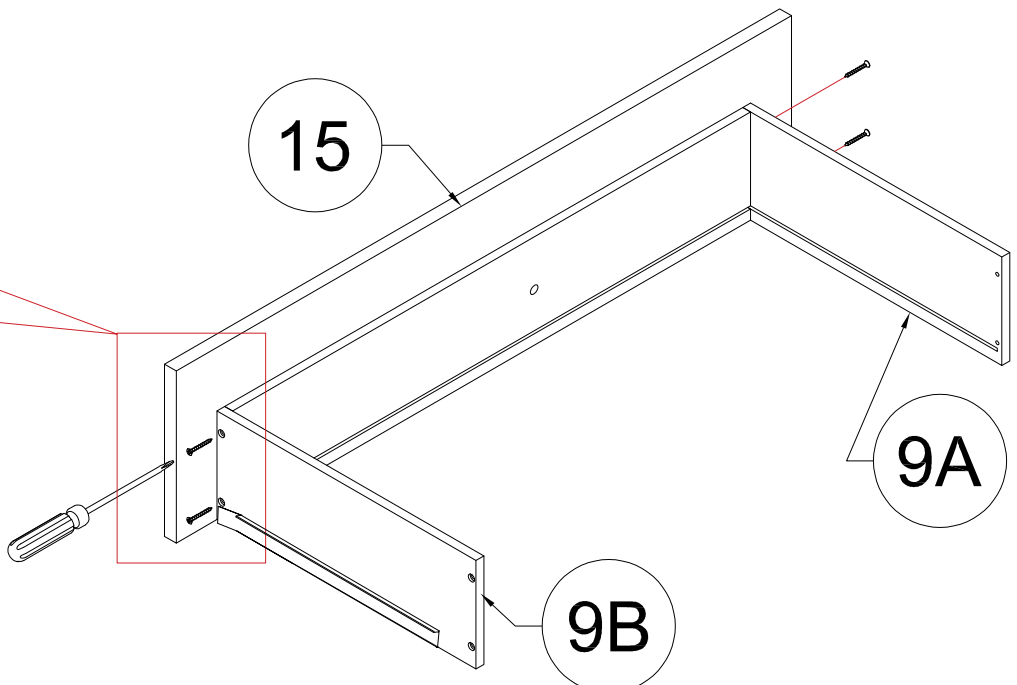

15

9A

9B

STEP 9.2: Following below illustration:

ÉTAPE 9.2 : Suivez l'illustration ci-dessous :

X2

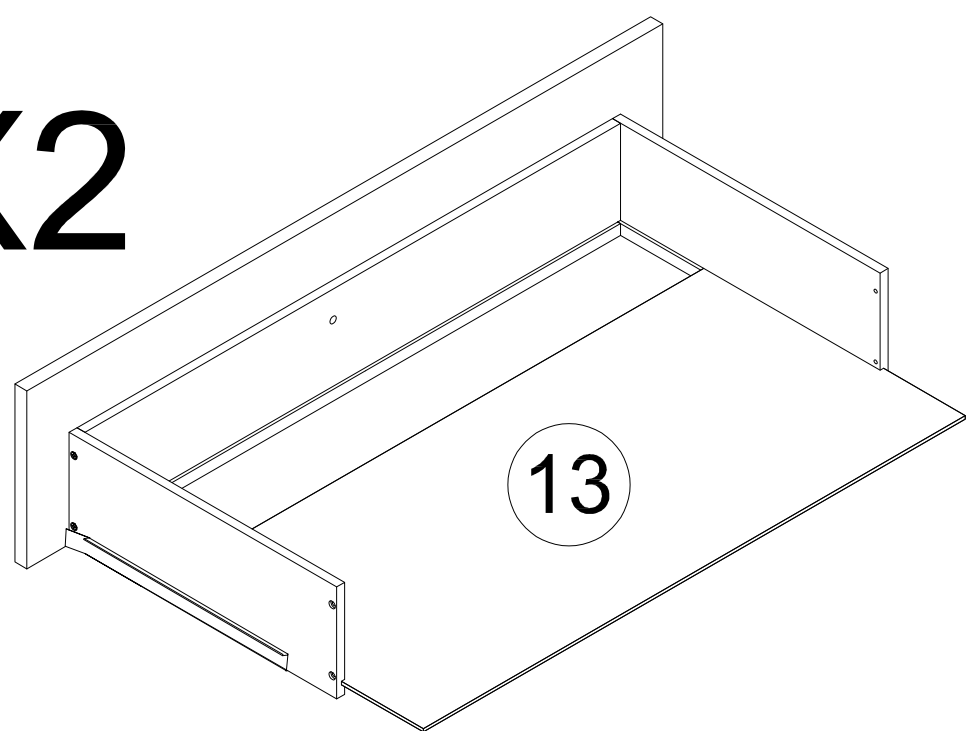



13

14

STEP 10.1: Following below illustration:

ÉTAPE 10.1 : Suivez l'illustration ci-dessous :

G		H		R	
8pcs		2pcs		2pcs	

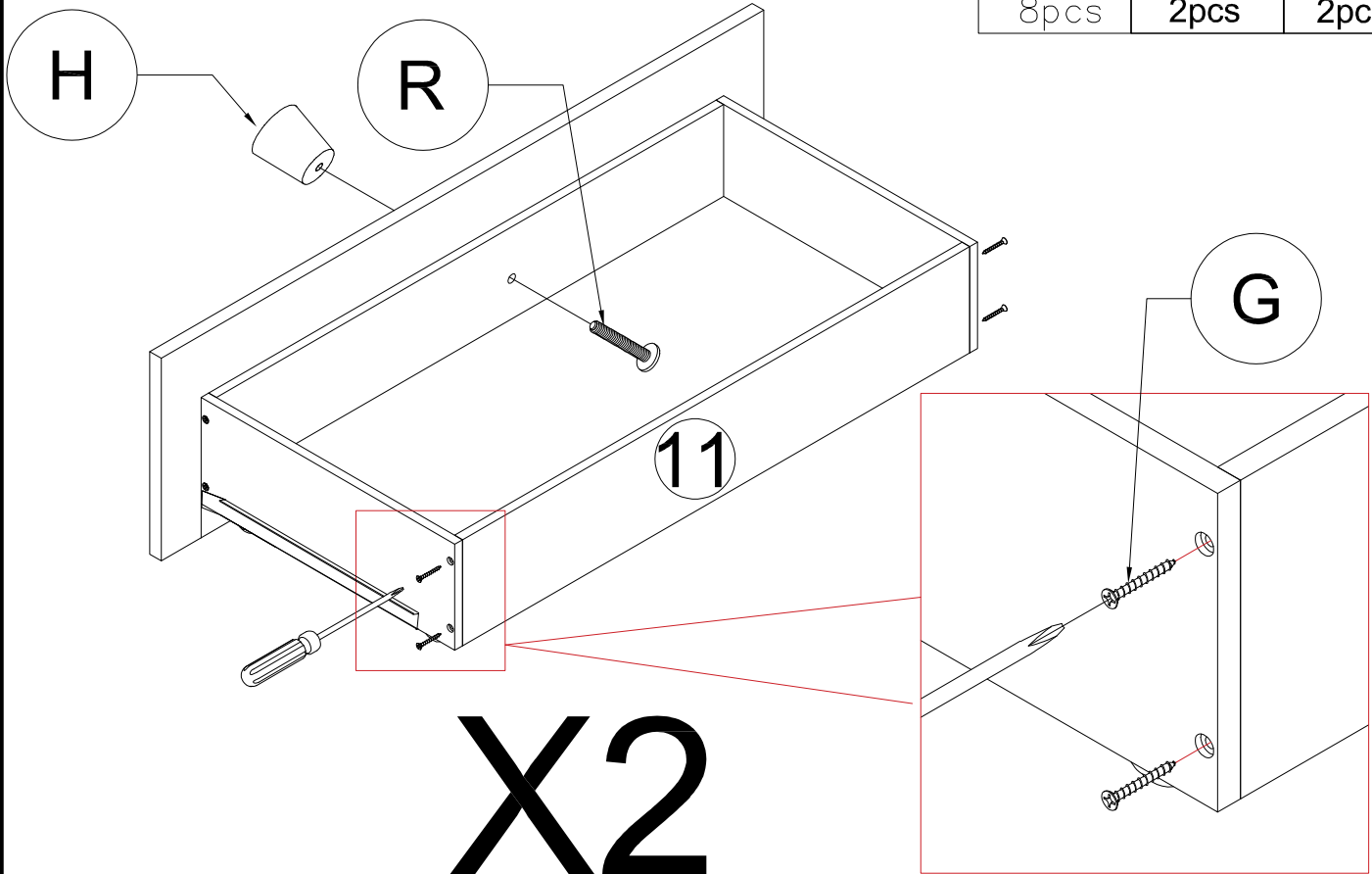

STEP 10.2: Following below illustration:

ÉTAPE 10.2 : Suivez l'illustration ci-dessous :

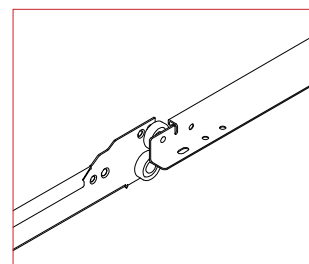
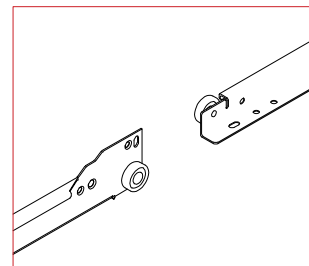
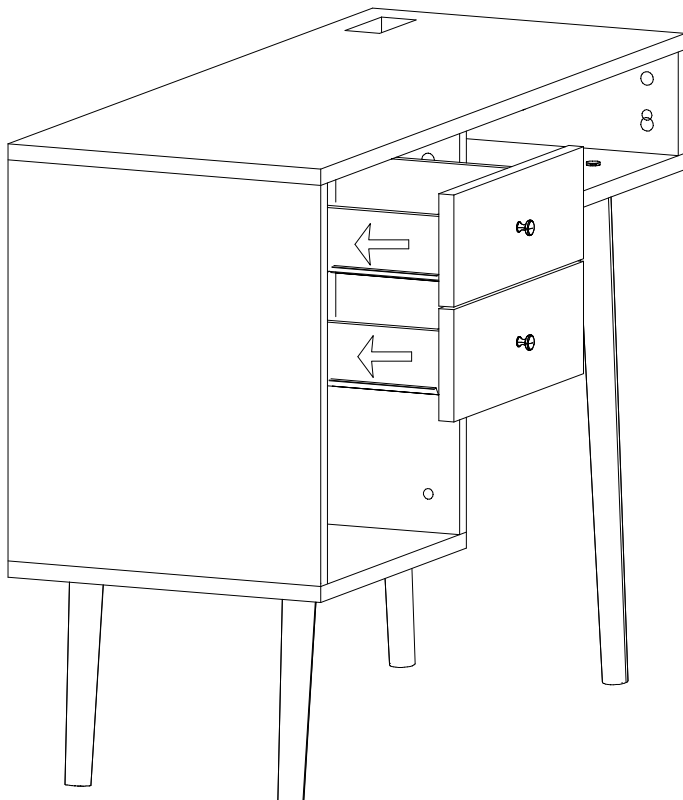

STEP 11.1: Following below illustration:

ÉTAPE 11.1 : Suivez l'illustration ci-dessous :

G



4pcs

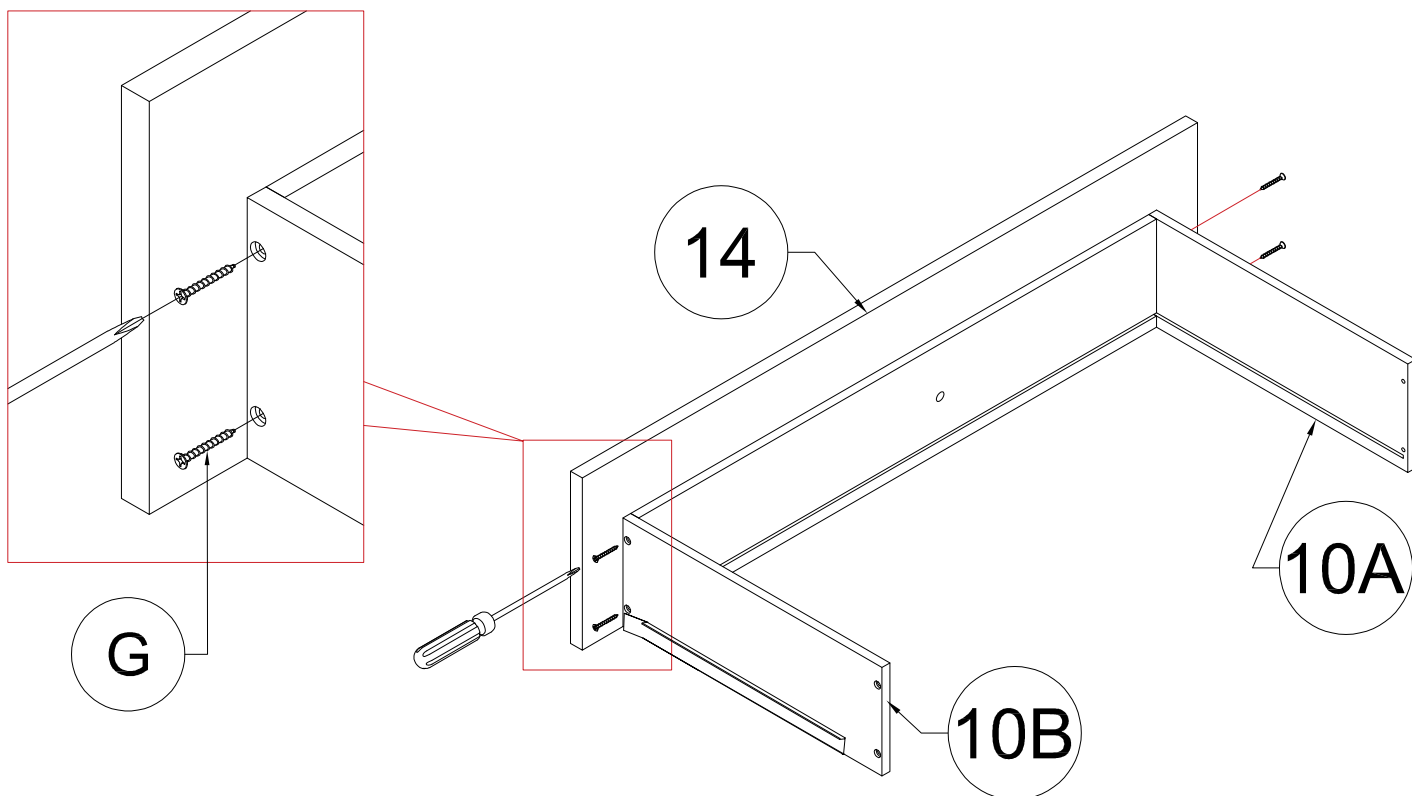

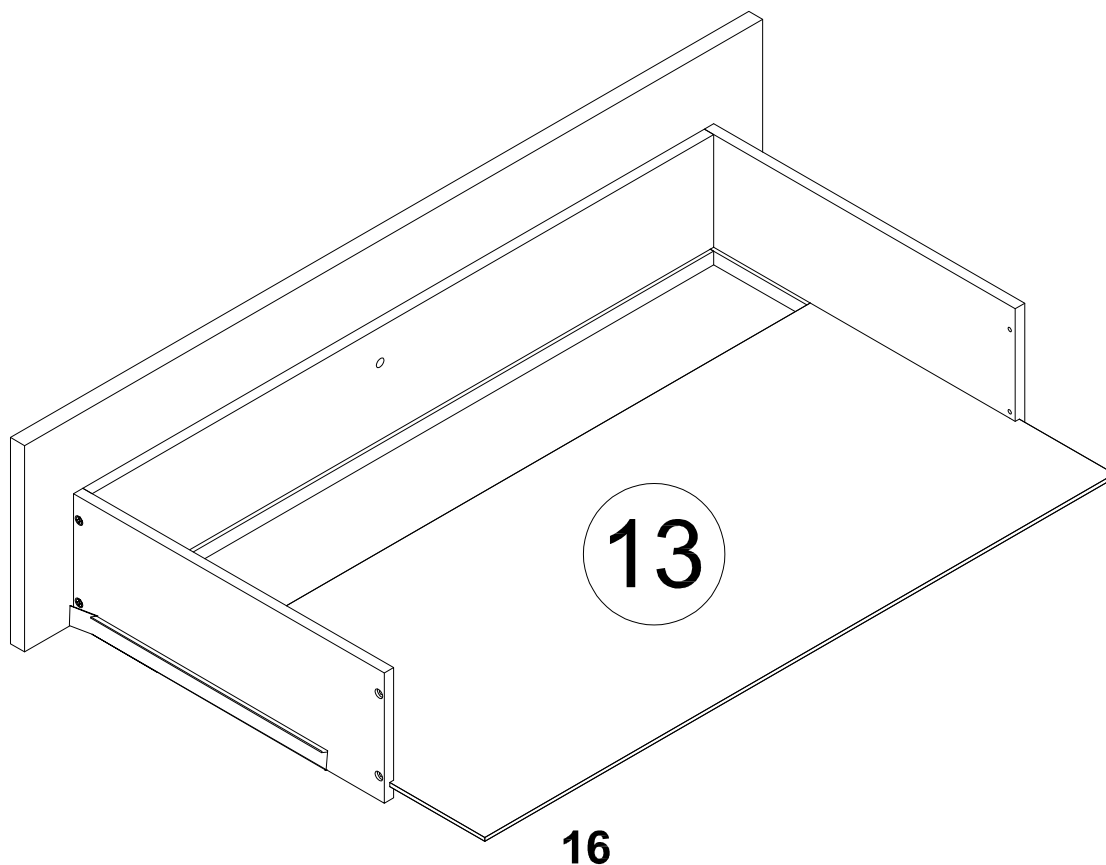

STEP 11.2: Following below illustration:

ÉTAPE 11.2 : Suivez l'illustration ci-dessous :



STEP 12.1: Following below illustration:

ÉTAPE 12.1 : Suivez l'illustration ci-dessous :

G		H		R	
	4pcs		1pc		1pc

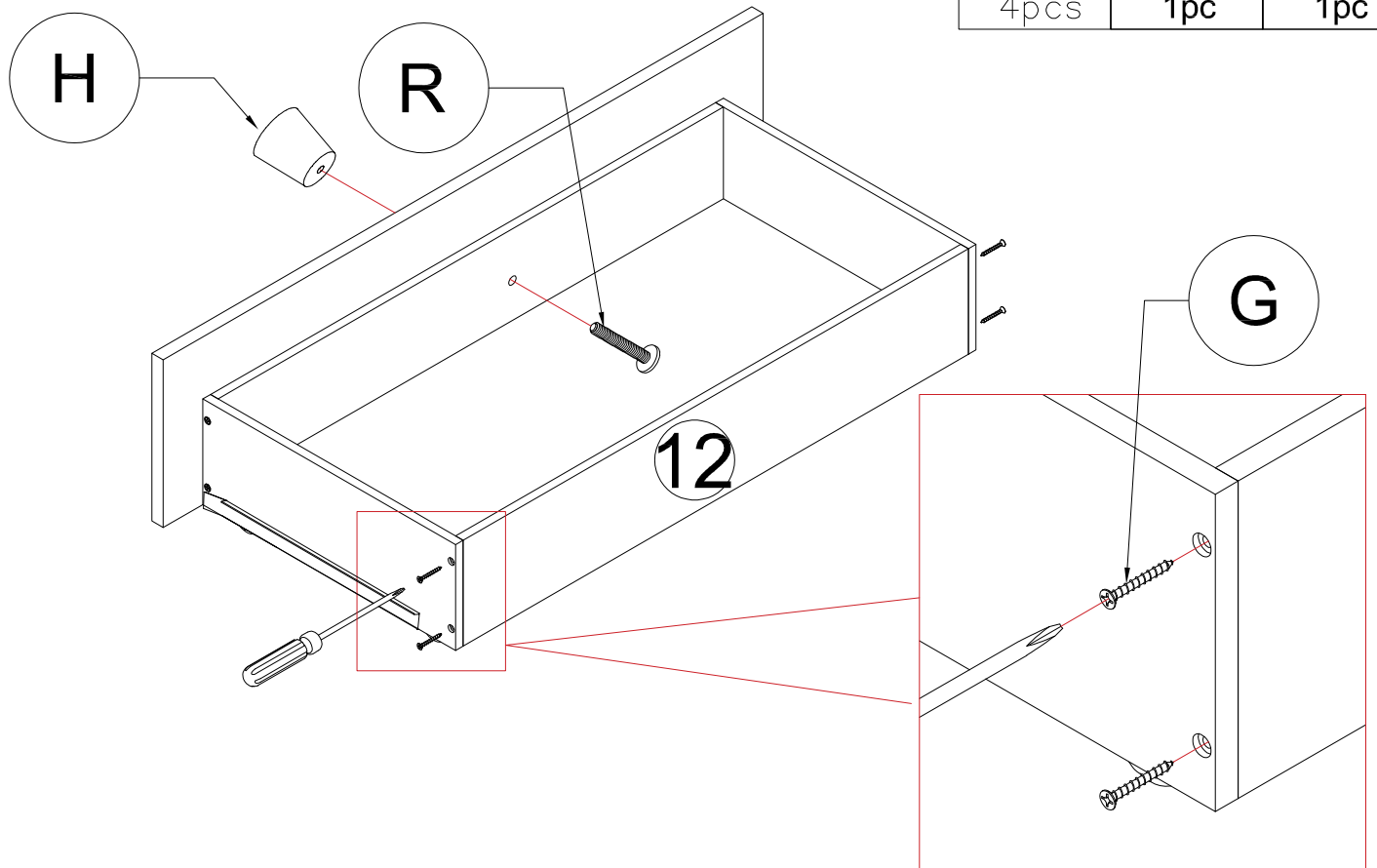

STEP 12.2: Following below illustration:

ÉTAPE 12.2 : Suivez l'illustration ci-dessous :

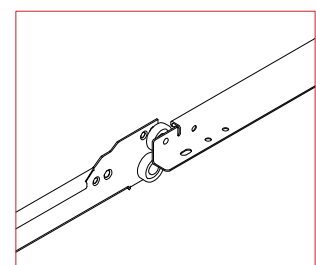
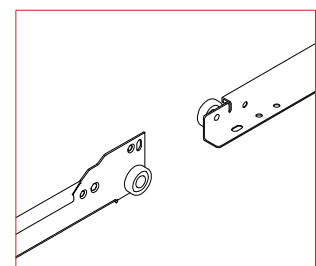
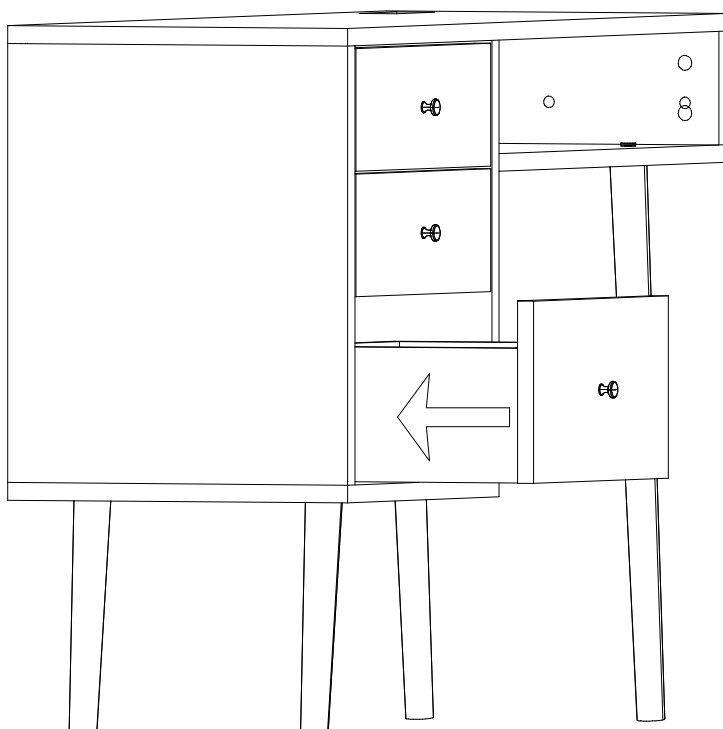

STEP 13.1: Following below illustration:

ÉTAPE 13.1 : Suivez l'illustration ci-dessous :

G	
4pcs	

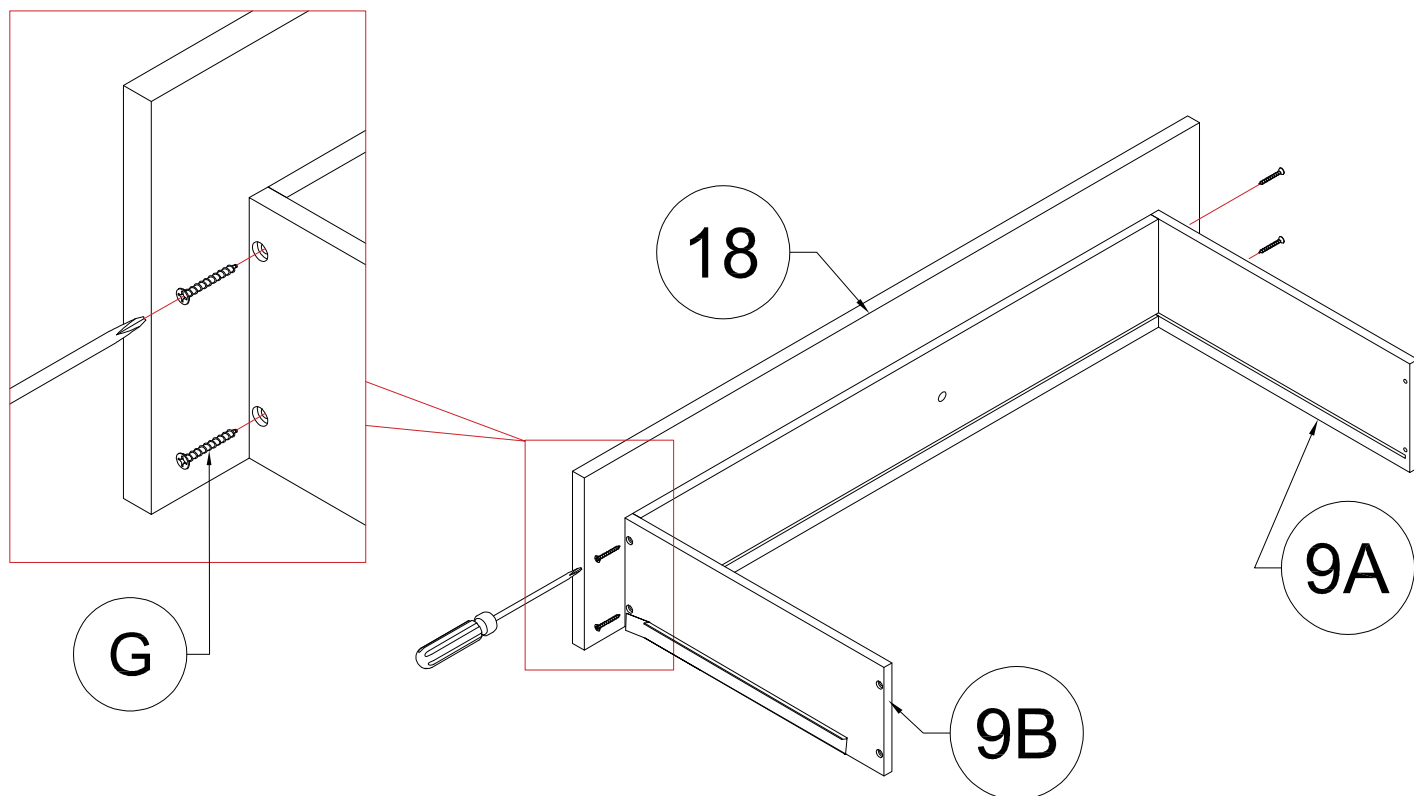

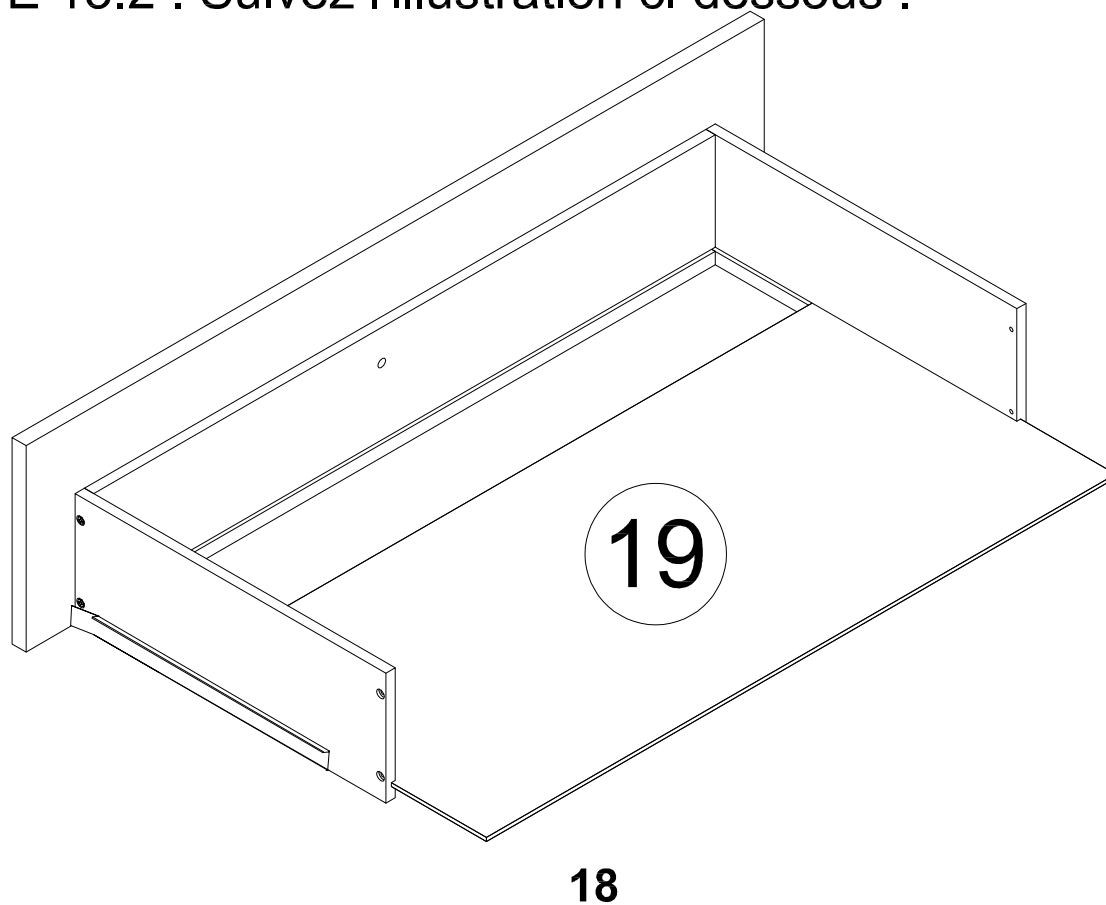

STEP 13.2: Following below illustration:

ÉTAPE 13.2 : Suivez l'illustration ci-dessous :



STEP 14.1: Following below illustration:

ÉTAPE 14.1 : Suivez l'illustration ci-dessous :

G		H		R	
	4pcs		1pc		1pc

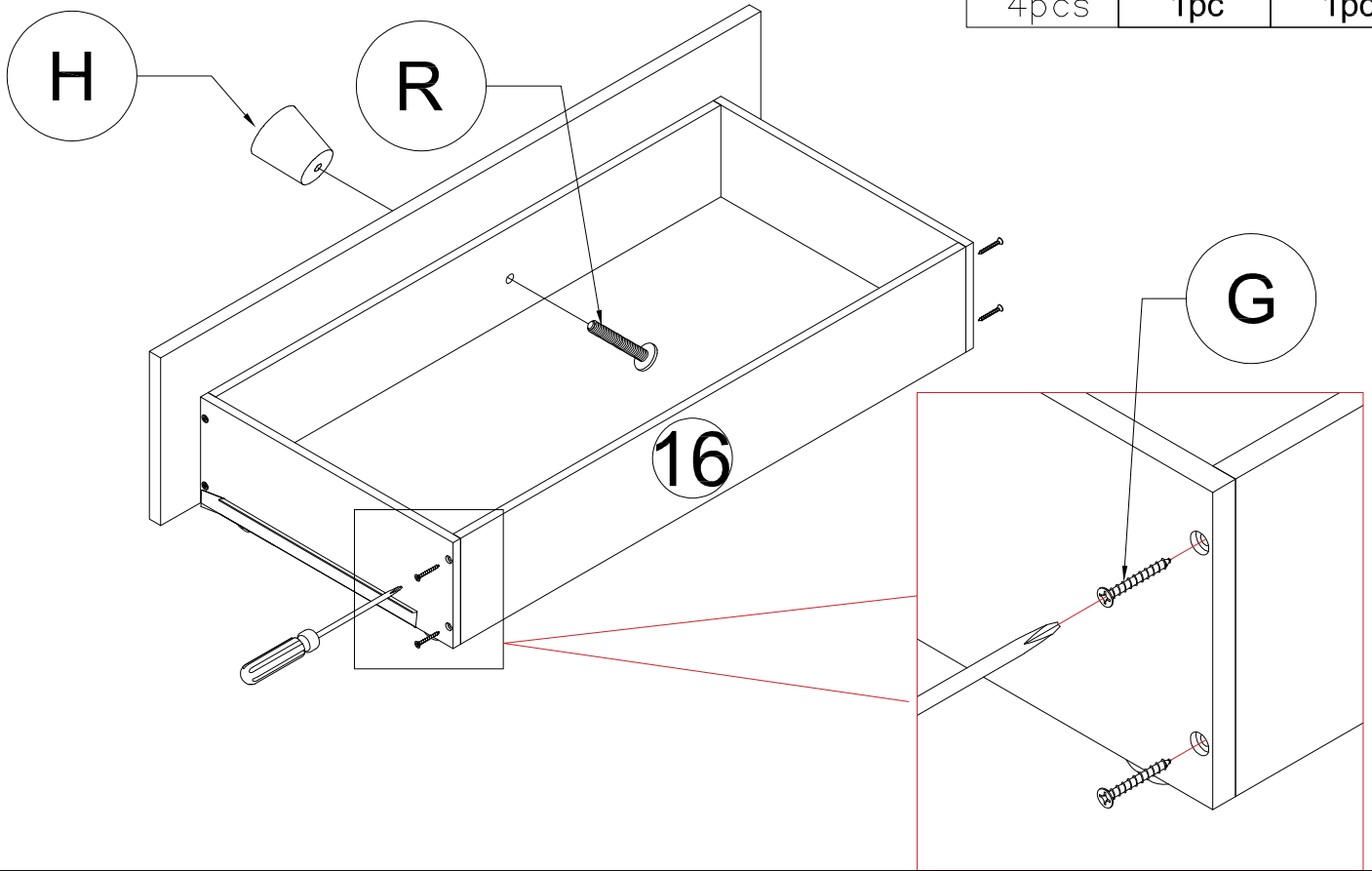

STEP 14.2: Following below illustration:

ÉTAPE 14.2 : Suivez l'illustration ci-dessous :

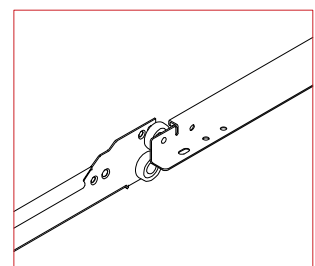
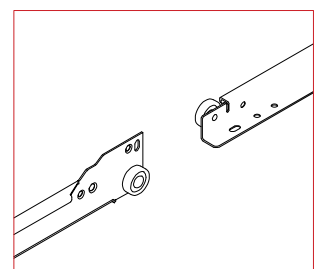
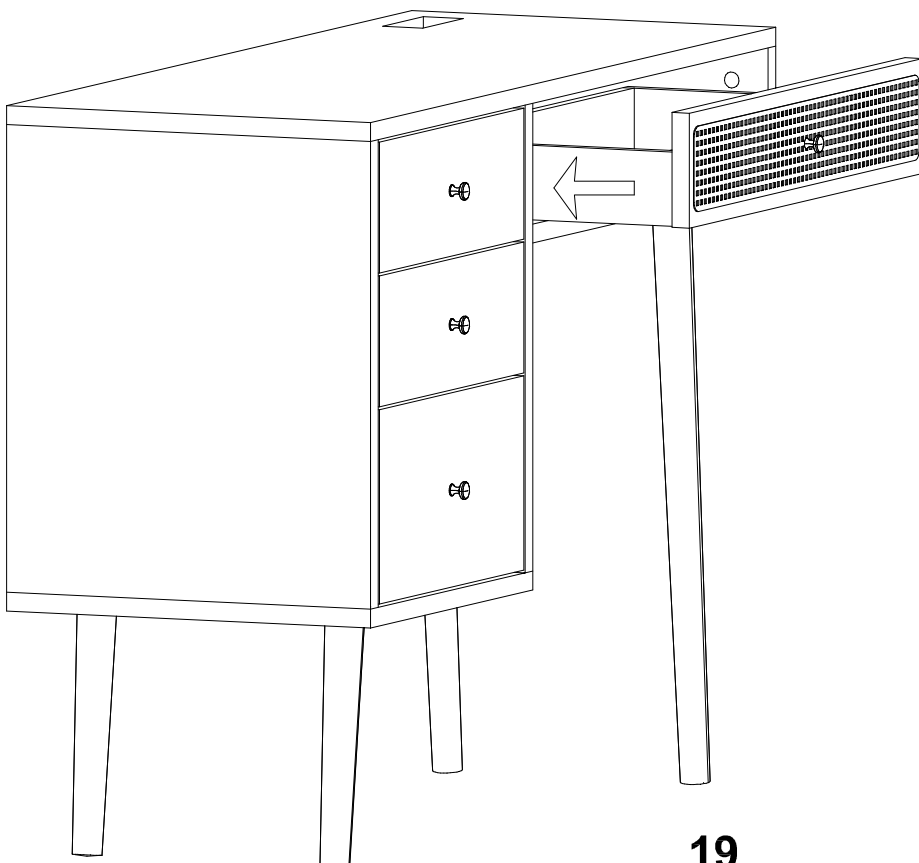

STEP 15: Following below illustration:

ÉTAPE 15 : Suivez l'illustration ci-dessous :

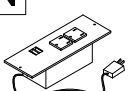
M		N	
2pcs		1pc	

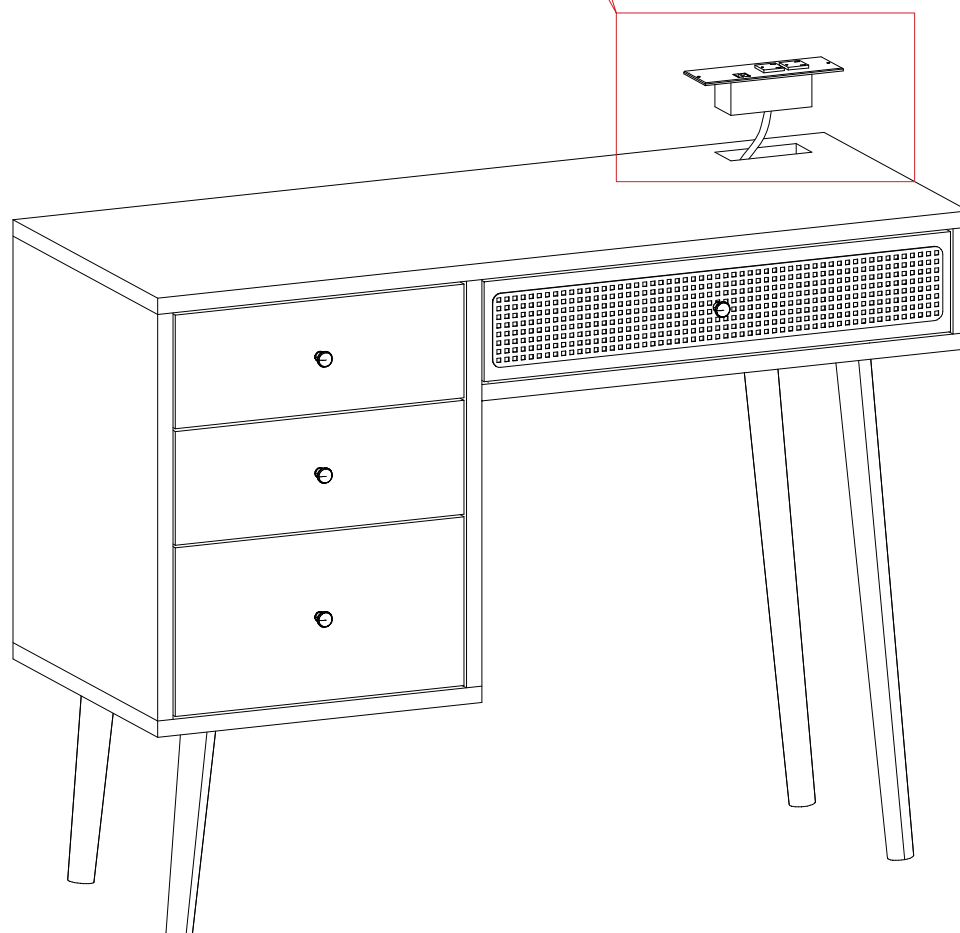
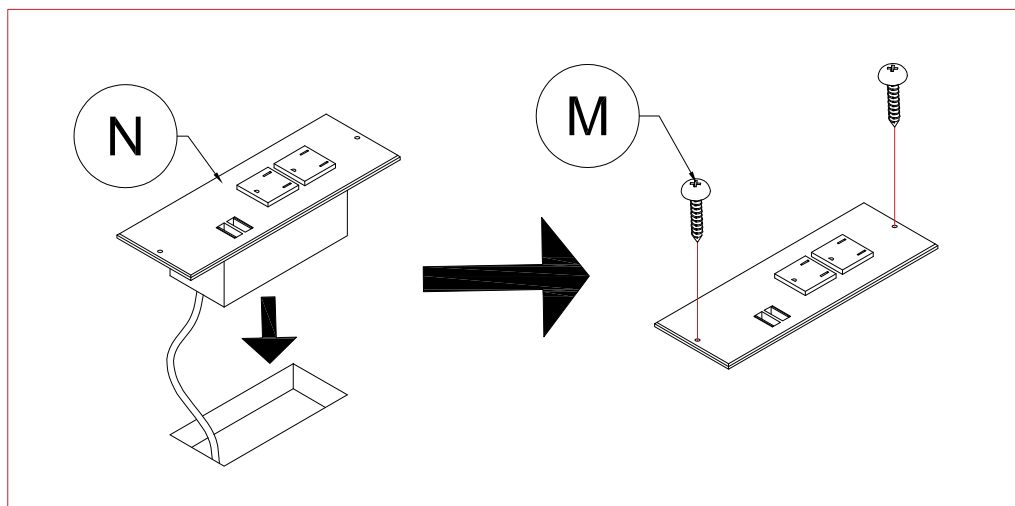

STEP 16: Following below illustration:

ÉTAPE 16 : Suivez l'illustration ci-dessous :

K



8pcs

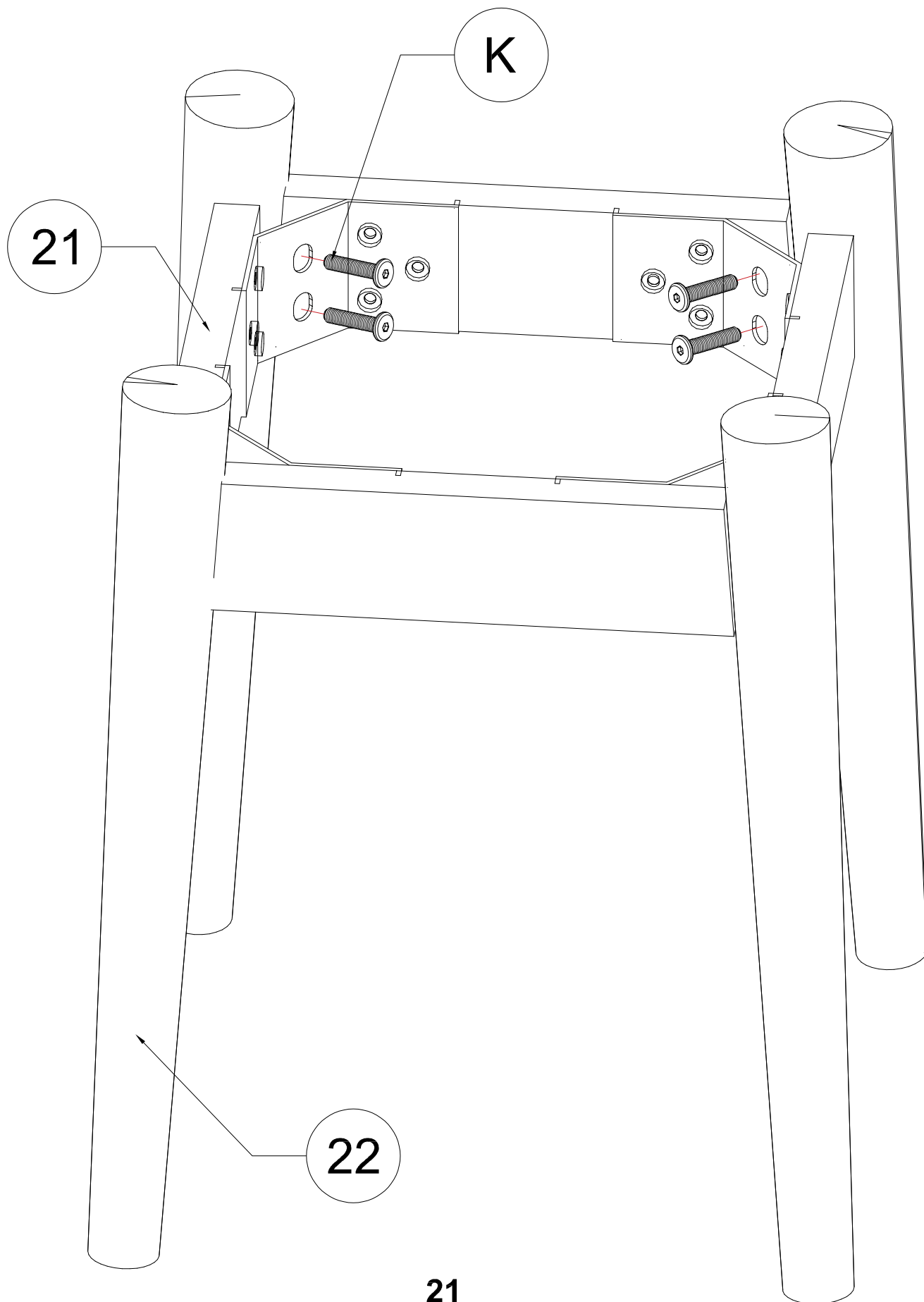

STEP 17: Following below illustration:

ÉTAPE 17 : Suivez l'illustration ci-dessous :

J	
4pcs	

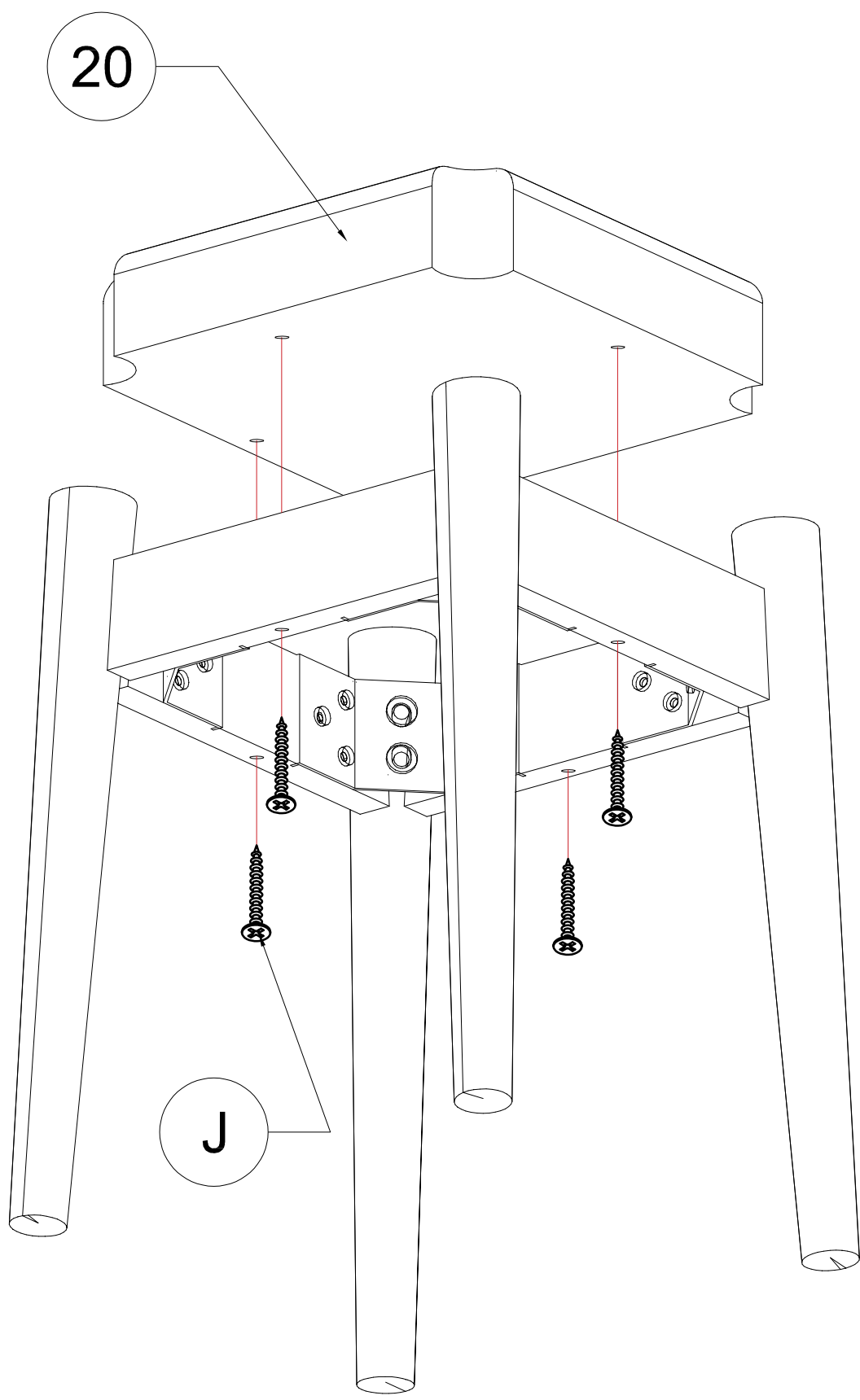

20

J

22

FINISH

