

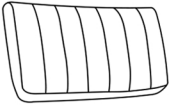



PARTS AND HARDWARE LIST

				 M6*40mm	
A*1	B*1	C*2	D*1	E*8	G*1

ASSEMBLY STEPS

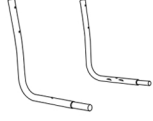
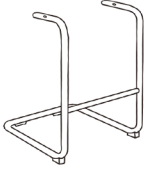
Assembly tip: Just tighten the screws to 80% before all of them are aligned. After all the screws are aligned, tighten the remaining parts.

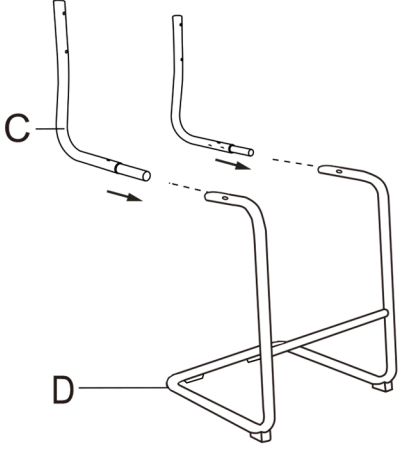
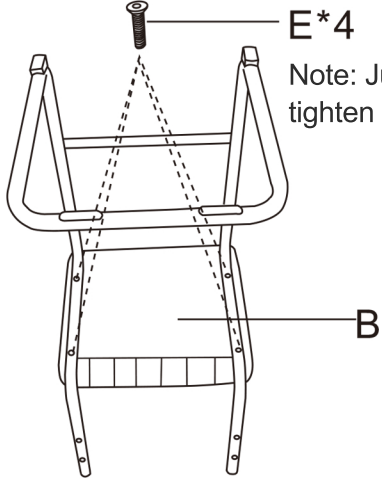
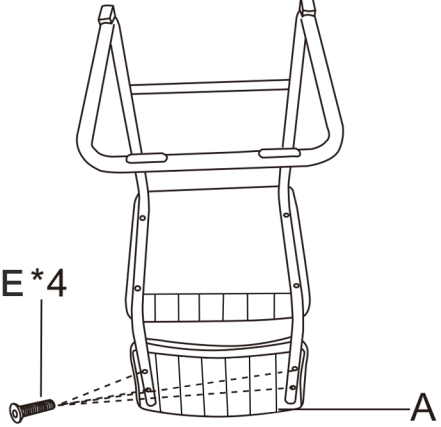
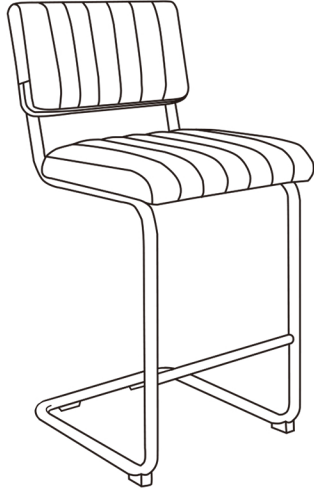
 <p>STEP 1. Insert frame parts (C) into the holes of part (D) as shown.</p>	 <p>STEP 2. All bolts/screws are lined up and inserted into the holes, attach seat cushion (B) to the metal unit part (E*4) assembled as shown, secure it well by using bolt and wrench.</p>
 <p>STEP 3. All bolts/screws are lined up and inserted into the holes, attach back part (A) to the metal unit part (E*4) assembled as shown, secure it well by using bolt and wrench.</p>	 <p>STEP 4. Finished chair</p>