

ASSEMBLY INSTRUCTION

DESCRIPTION: ROUND END TABLE

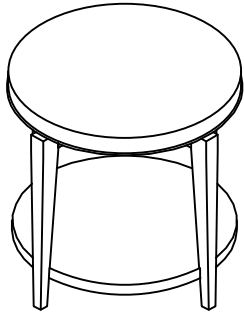

PARTS LIST

NO.	SKETCH	DESCRIPTION	QTY
1		Top	1pc
2		Shelf	1pc
3		Legs	4pcs
4		Rail-1	1pc
5		Rail-2	1pc

6

HARDWARE LIST

NO.	SKETCH	DESCRIPTION	SIZE	QTY
A		Curved washer	1/4"*24*8*12mm	8pcs
B		Flat washer	Ø1/4"*16mm	17pcs
C		Lock washer	Ø1/4"	17pcs
D		Bolt	Ø1/4"*55mm	17pcs
E		Allen wrench	M4	1pc

STEP 1

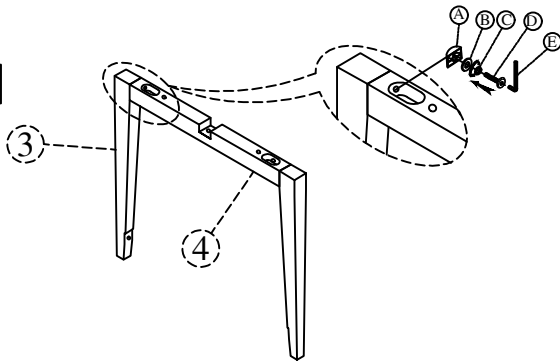

STEP 2

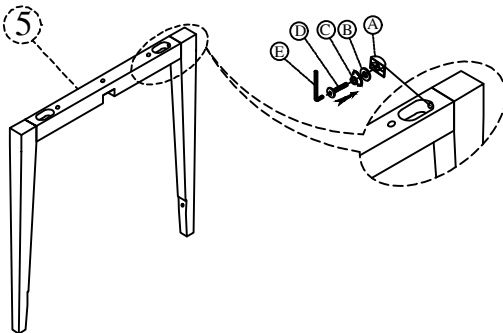

STEP 3

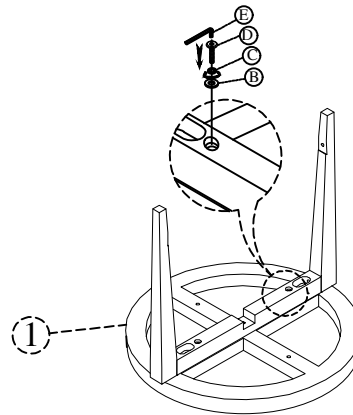

STEP 4

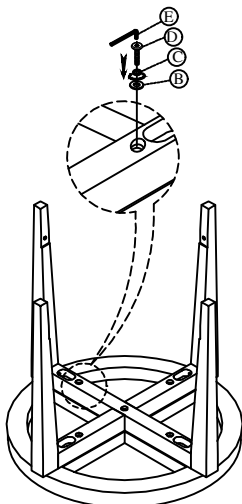

STEP 5

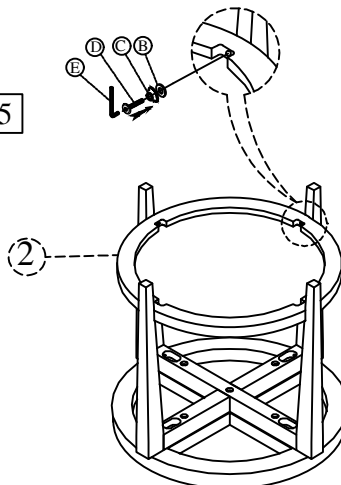

FINISH

