

ASSEMBLY INSTRUCTIONS

ASSEMBLY INSTRUCTIONS

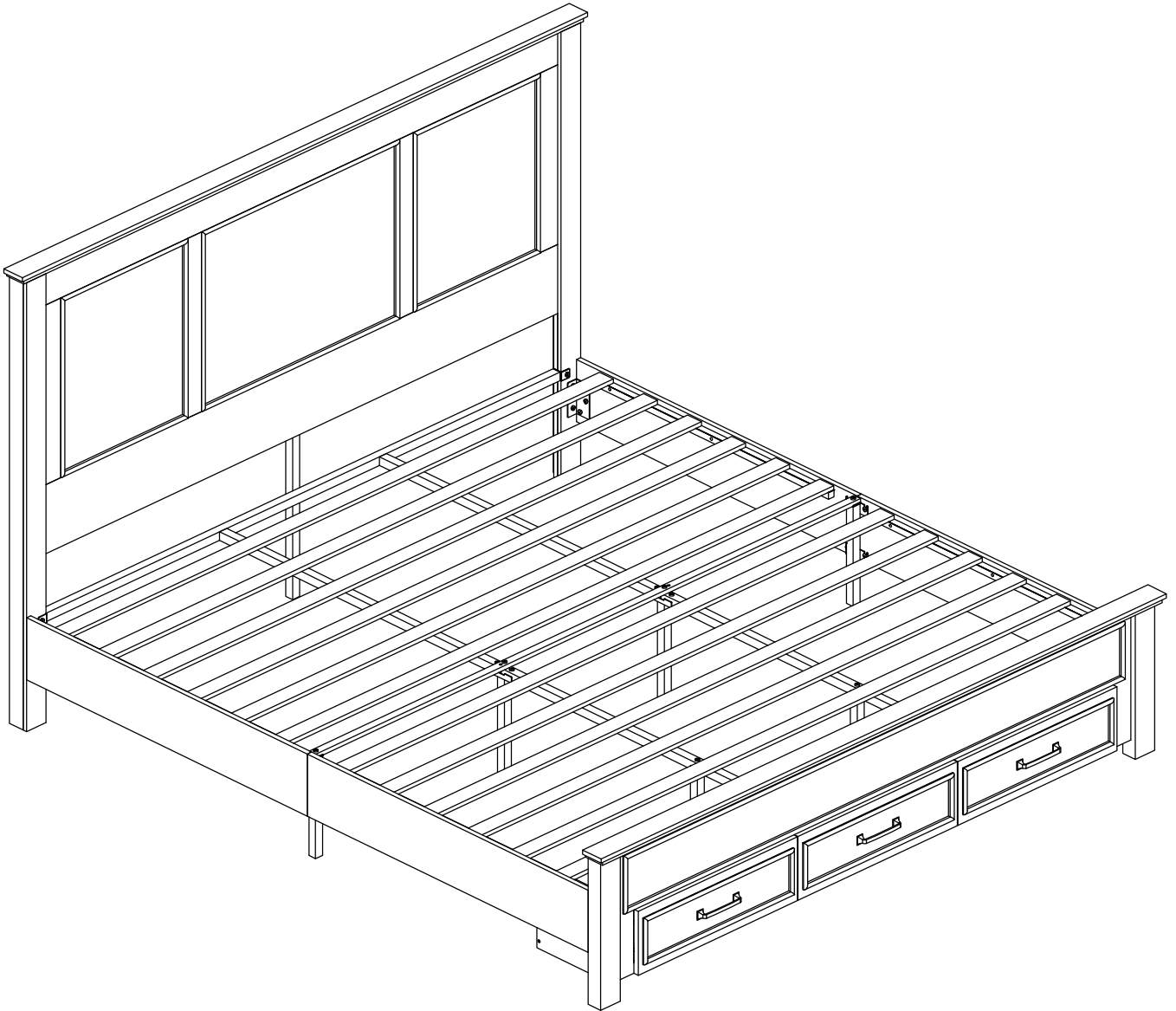

Dear Customers,
Thank you for purchasing our product. Please read this instruction manual carefully after receiving this product. It will help you assemble this product quickly, safely and correctly. You can keep this manual for future reference.
MADE IN CHINA

ASSEMBLY INSTRUCTIONS



Please follow the instruction manuals and use a pad to protect the product during your assembly.

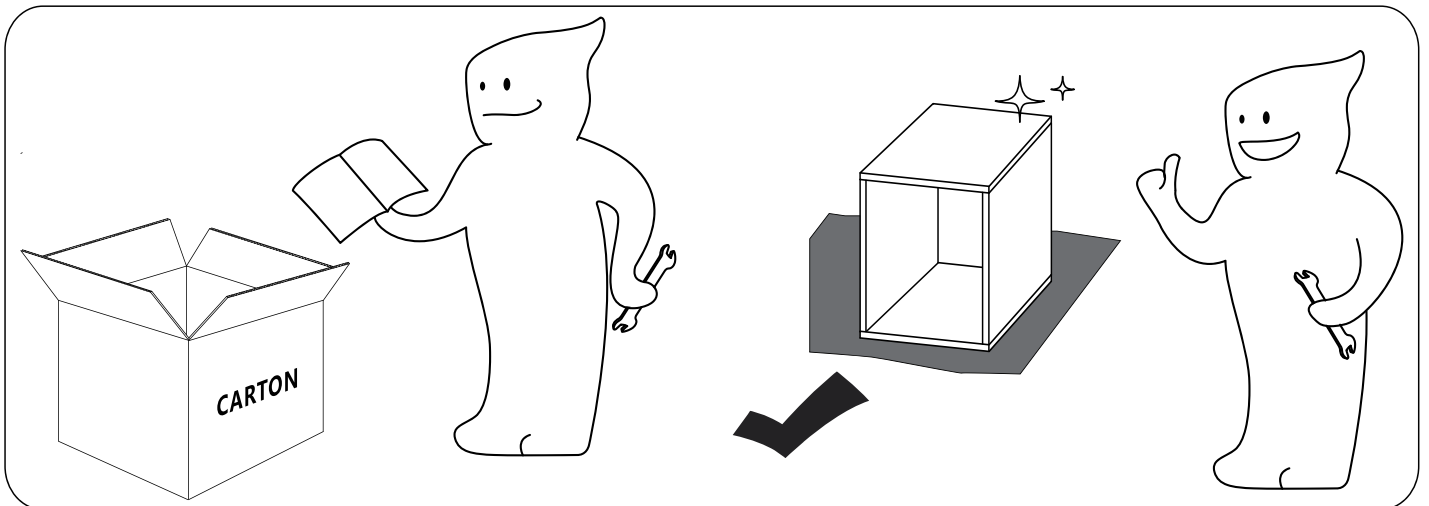
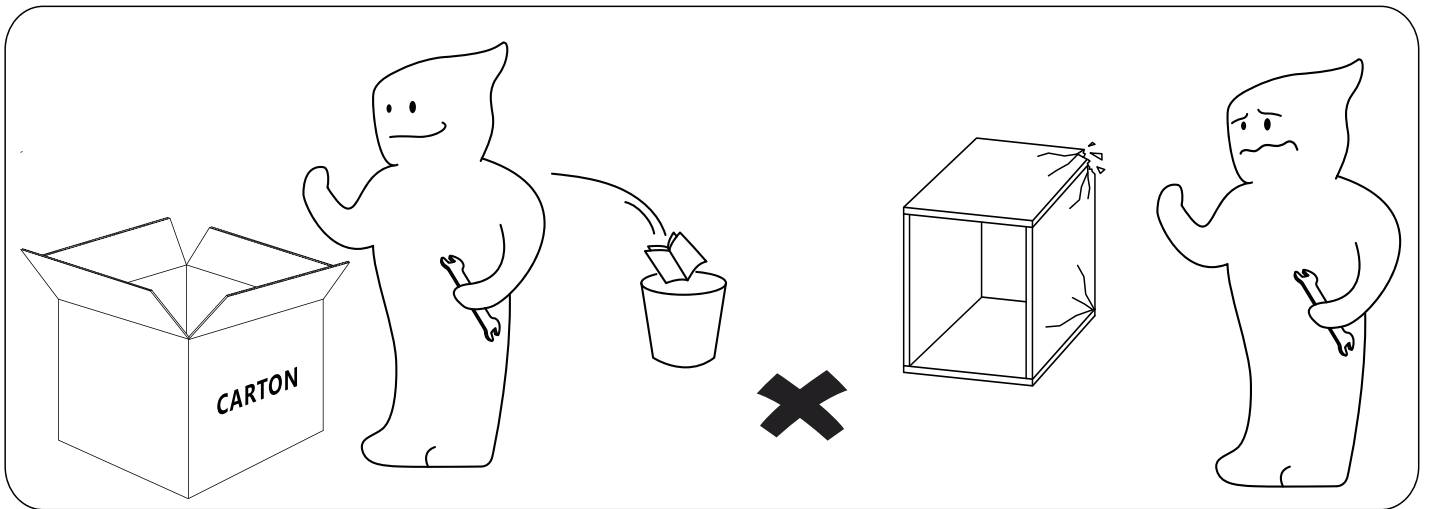

Note:

1. Should be assembled on flat ground to keep balance.
2. Before completing the installation, do not tighten the screws.

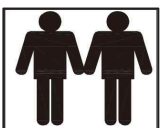



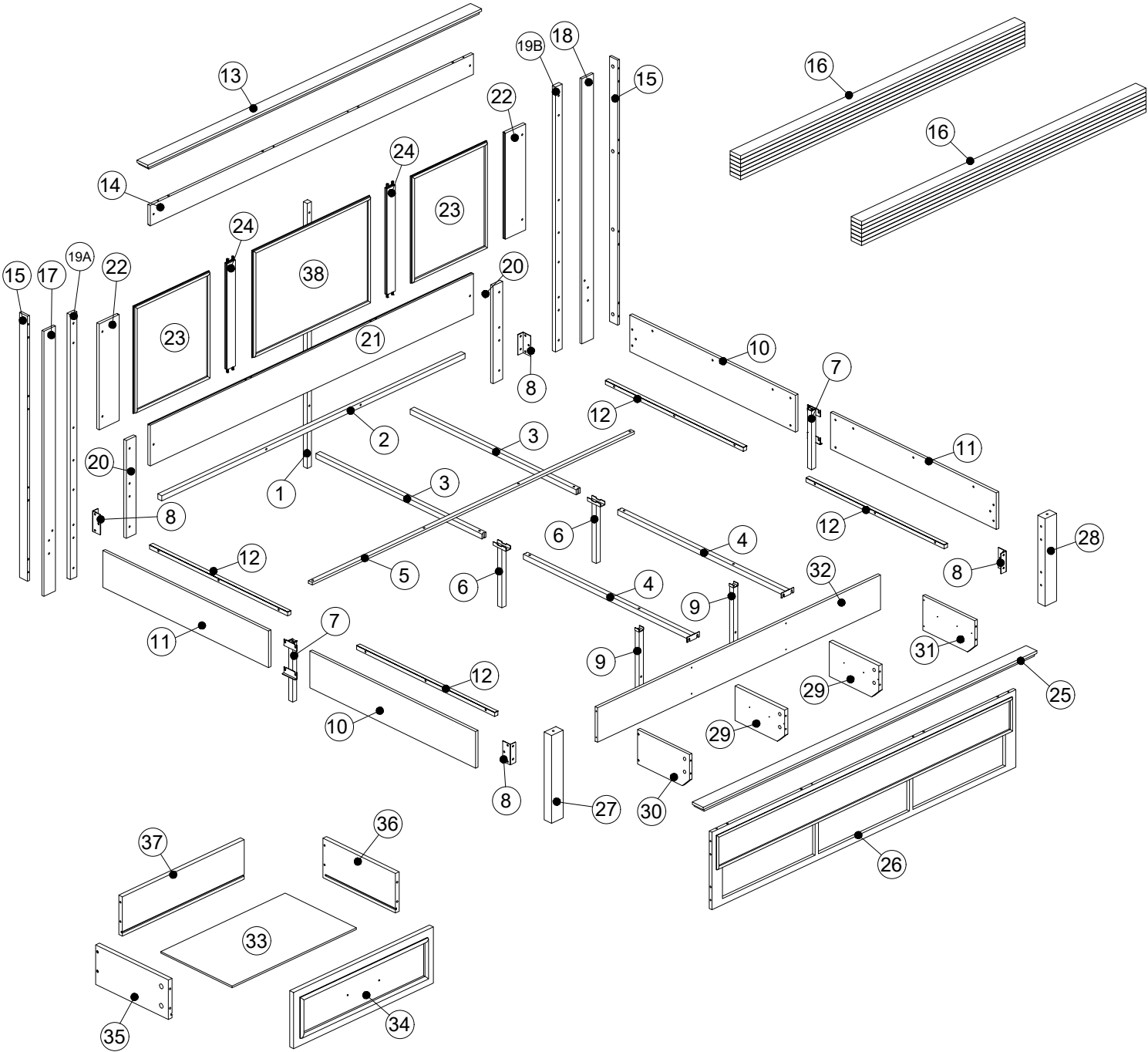

For easier and better assembly, **2** or more adults are required.

ASSEMBLY INSTRUCTIONS



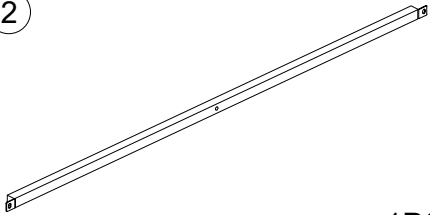
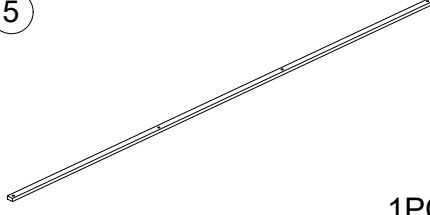
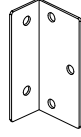
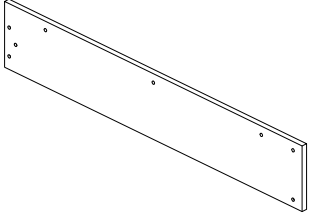
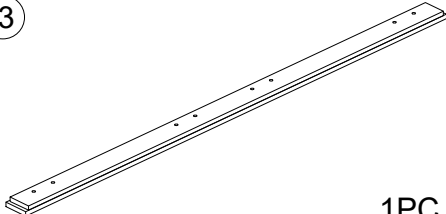
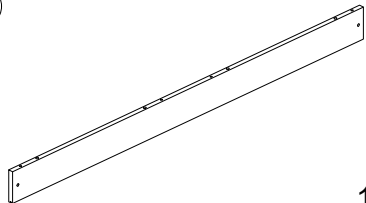
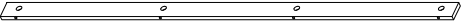
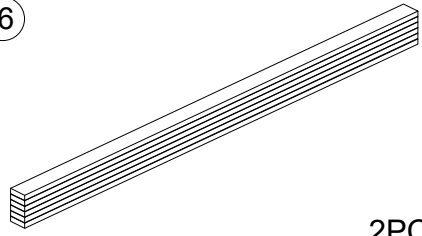

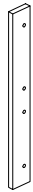
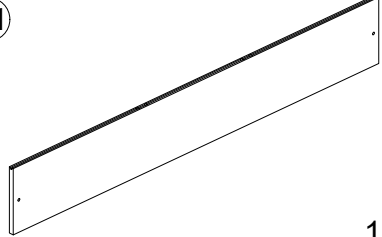

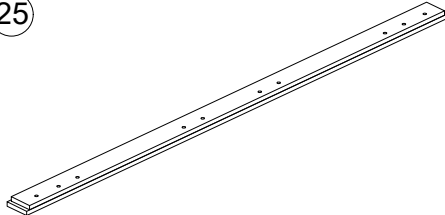
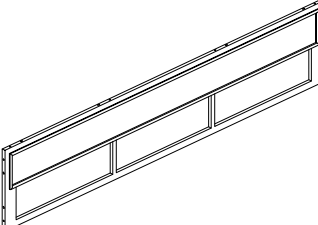
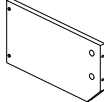
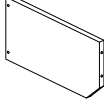
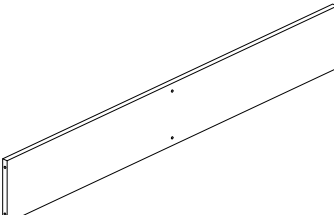
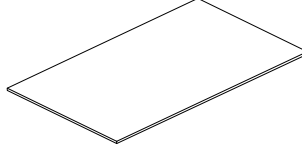

ASSEMBLY INSTRUCTIONS

In Box 1

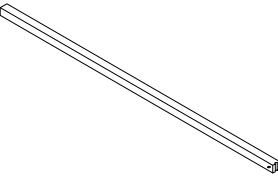
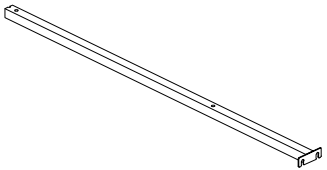
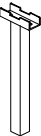
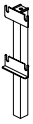
 <p>2</p> <p>1PC</p>	 <p>5</p> <p>1PC</p>	 <p>8</p> <p>4PCS</p>
 <p>10</p> <p>1PC</p>	 <p>13</p> <p>1PC</p>	 <p>14</p> <p>1PC</p>
 <p>15</p> <p>2PCS</p>	 <p>16</p> <p>2PCS</p>	 <p>17</p> <p>1PC</p>
 <p>18</p> <p>1PC</p>	 <p>20</p> <p>1PC</p>	 <p>21</p> <p>1PC</p>
 <p>22</p> <p>2PCS</p>	 <p>24</p> <p>2PCS</p>	 <p>25</p> <p>1PC</p>
 <p>26</p> <p>1PC</p>	 <p>30</p> <p>1PC</p>	 <p>31</p> <p>1PC</p>
 <p>32</p> <p>1PC</p>	 <p>33</p> <p>3PCS</p>	

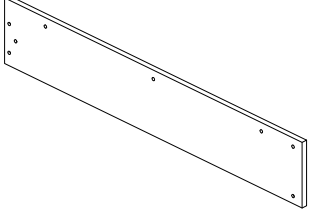
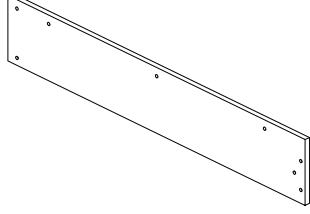
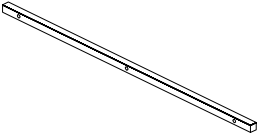
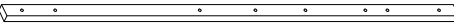
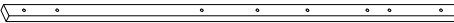

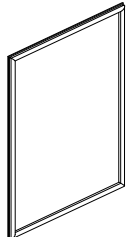

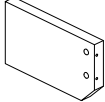
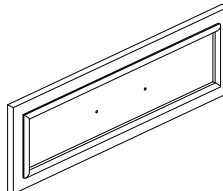
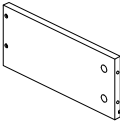
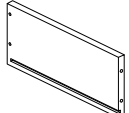
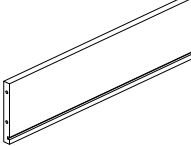
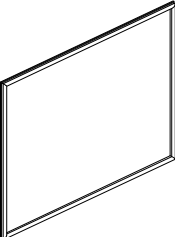

ASSEMBLY INSTRUCTIONS

In Box 2

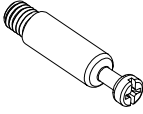
<p>①</p>  <p>1PC</p>	<p>③</p>  <p>2PCS</p>	<p>④</p>  <p>2PCS</p>
<p>⑥</p>  <p>2PCS</p>	<p>⑦</p>  <p>2PCS</p>	<p>⑨</p>  <p>2PCS</p>
<p>⑩</p>  <p>1PC</p>	<p>⑪</p>  <p>2PCS</p>	<p>⑫</p>  <p>4PCS</p>
<p>⑰A</p>  <p>1PC</p>	<p>⑰B</p>  <p>1PC</p>	<p>⑳</p>  <p>1PC</p>
<p>⑳</p>  <p>2PCS</p>	<p>㉓</p>  <p>1PC</p>	<p>㉔</p>  <p>1PC</p>
<p>㉖</p>  <p>2PCS</p>	<p>㉘</p>  <p>3PCS</p>	<p>㉙</p>  <p>3PCS</p>
<p>㉚</p>  <p>3PCS</p>	<p>㉜</p>  <p>3PCS</p>	<p>㉝</p>  <p>1PC</p>

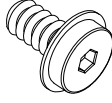
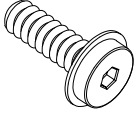
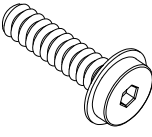
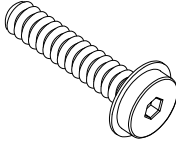
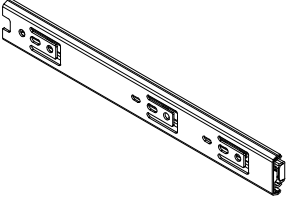
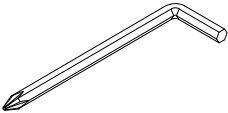
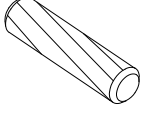
ASSEMBLY INSTRUCTIONS

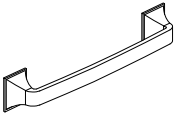
In Box 1

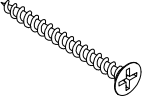
<p>A</p>  <p>40PCS+1PC</p>	<p>B</p>  <p>40PCS+1PC</p>	<p>C</p>  <p>M8*12mm 30PCS+1PC</p>
<p>D</p>  <p>M8*35mm 4PCS</p>	<p>E</p>  <p>M8*30mm 14PCS+1PC</p>	<p>F</p>  <p>M8*45mm 27PCS+1PC</p>
<p>G</p>  <p>6PCS</p>	<p>H</p>  <p>M5 1PC</p>	<p>I</p>  <p>Ø6*30mm 22PCS+1PC</p>
<p>J</p>  <p>6PCS</p>	<p>K</p>  <p>3PCS</p>	<p>L</p>  <p>Ø3.5*15mm 36PCS+1PC</p>
<p>M</p>  <p>Ø4*30mm 20PCS+1PC</p>		

ASSEMBLY INSTRUCTIONS

1

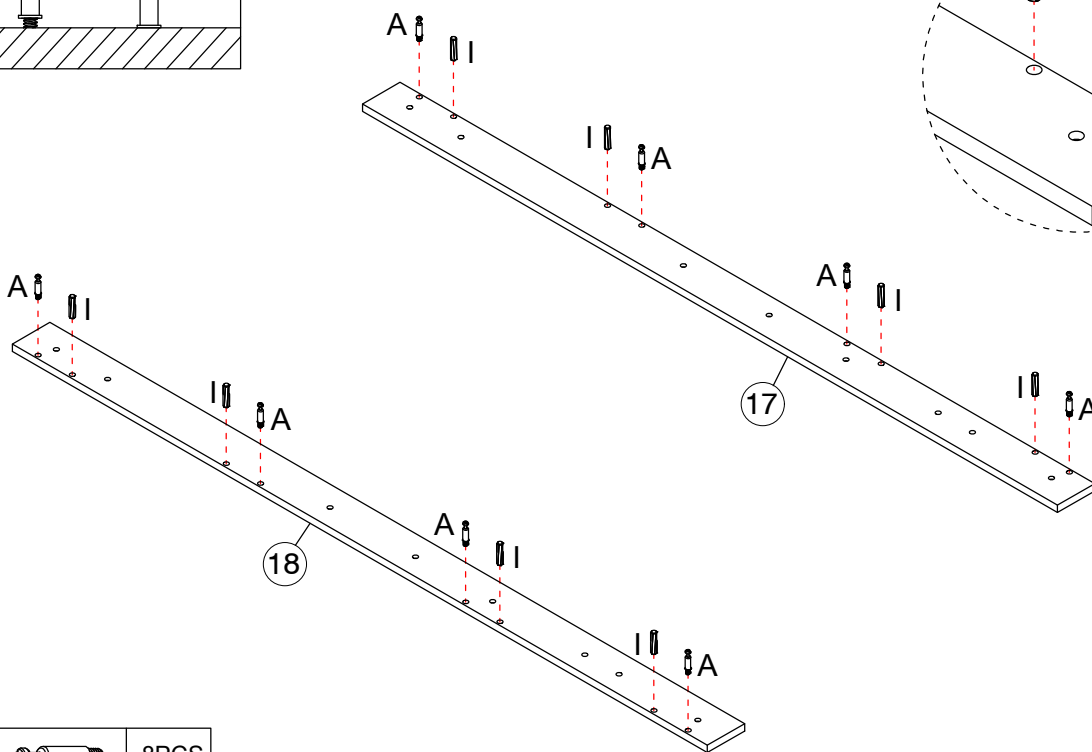
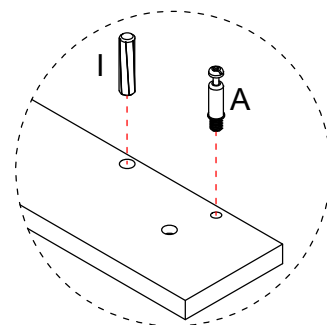
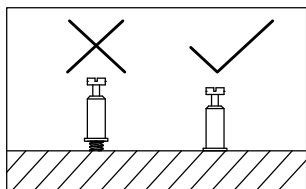

A		8PCS
I		8PCS

2

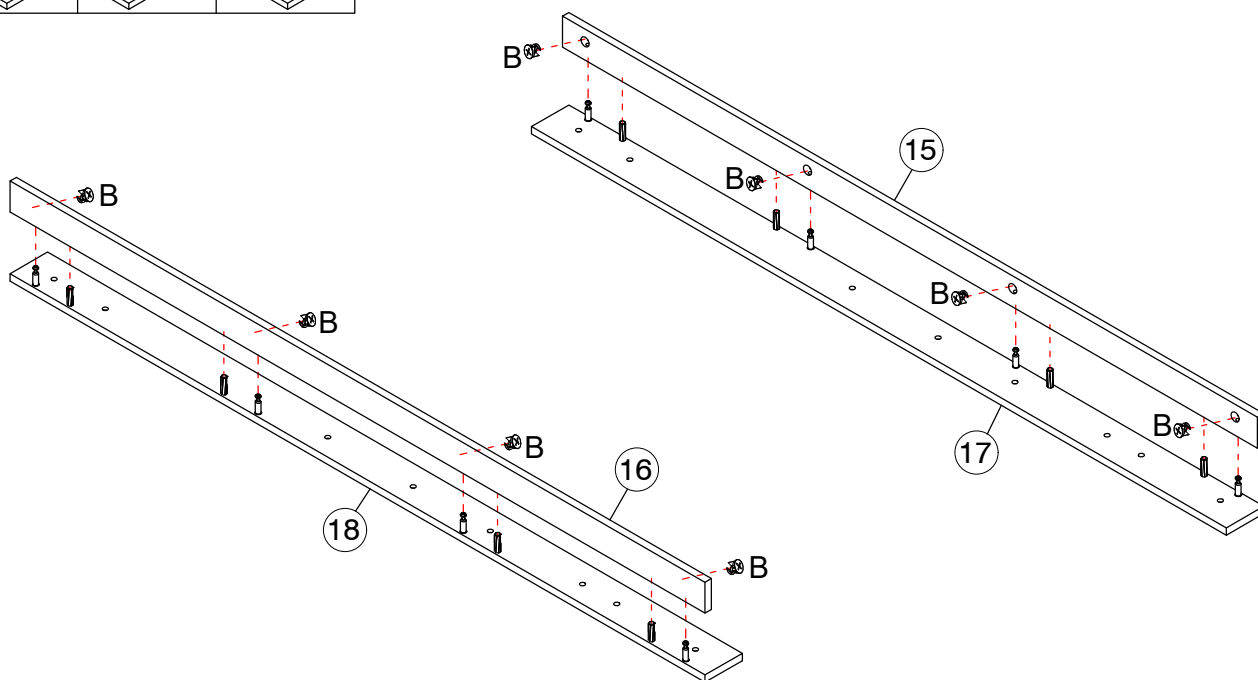
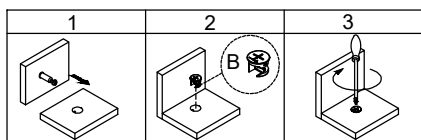

B		8PCS
---	--	------

ASSEMBLY INSTRUCTIONS

3

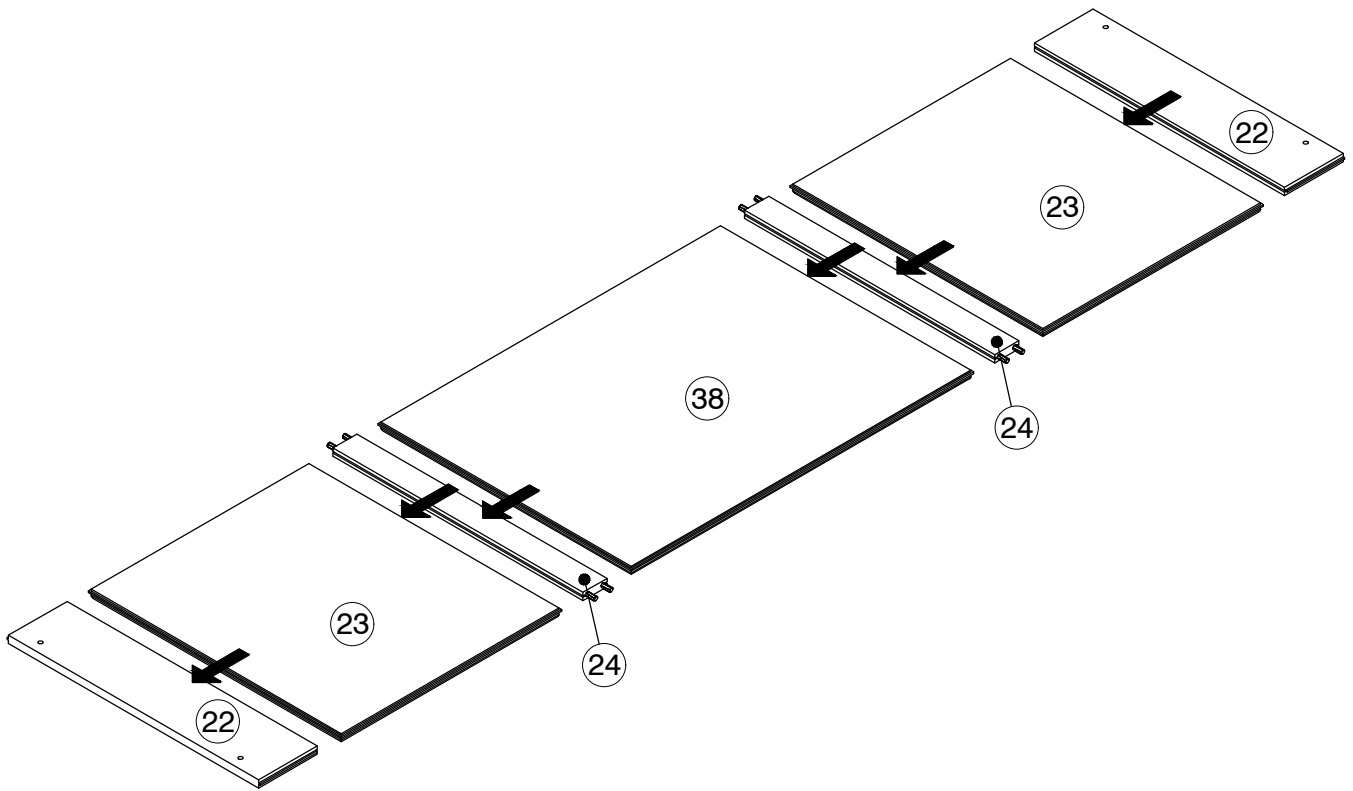

4

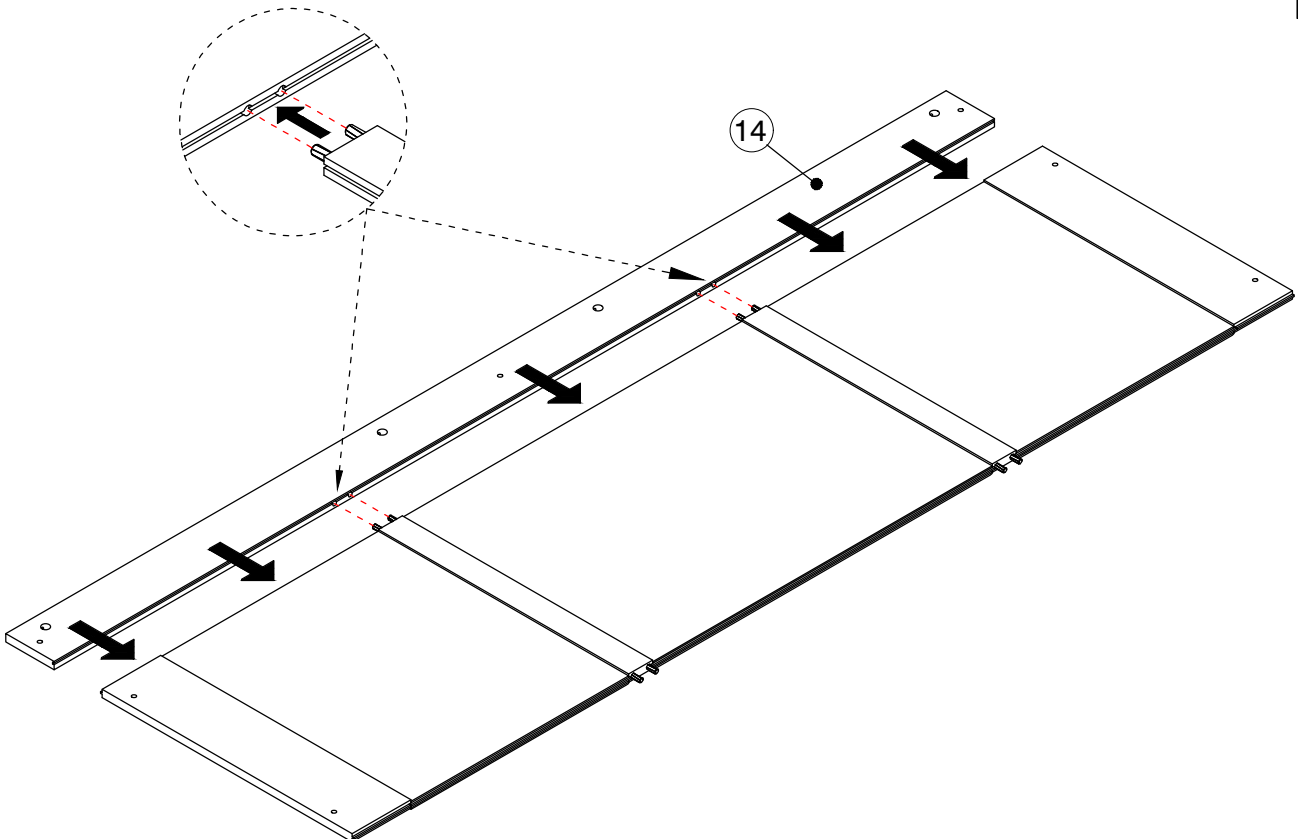

ASSEMBLY INSTRUCTIONS

5

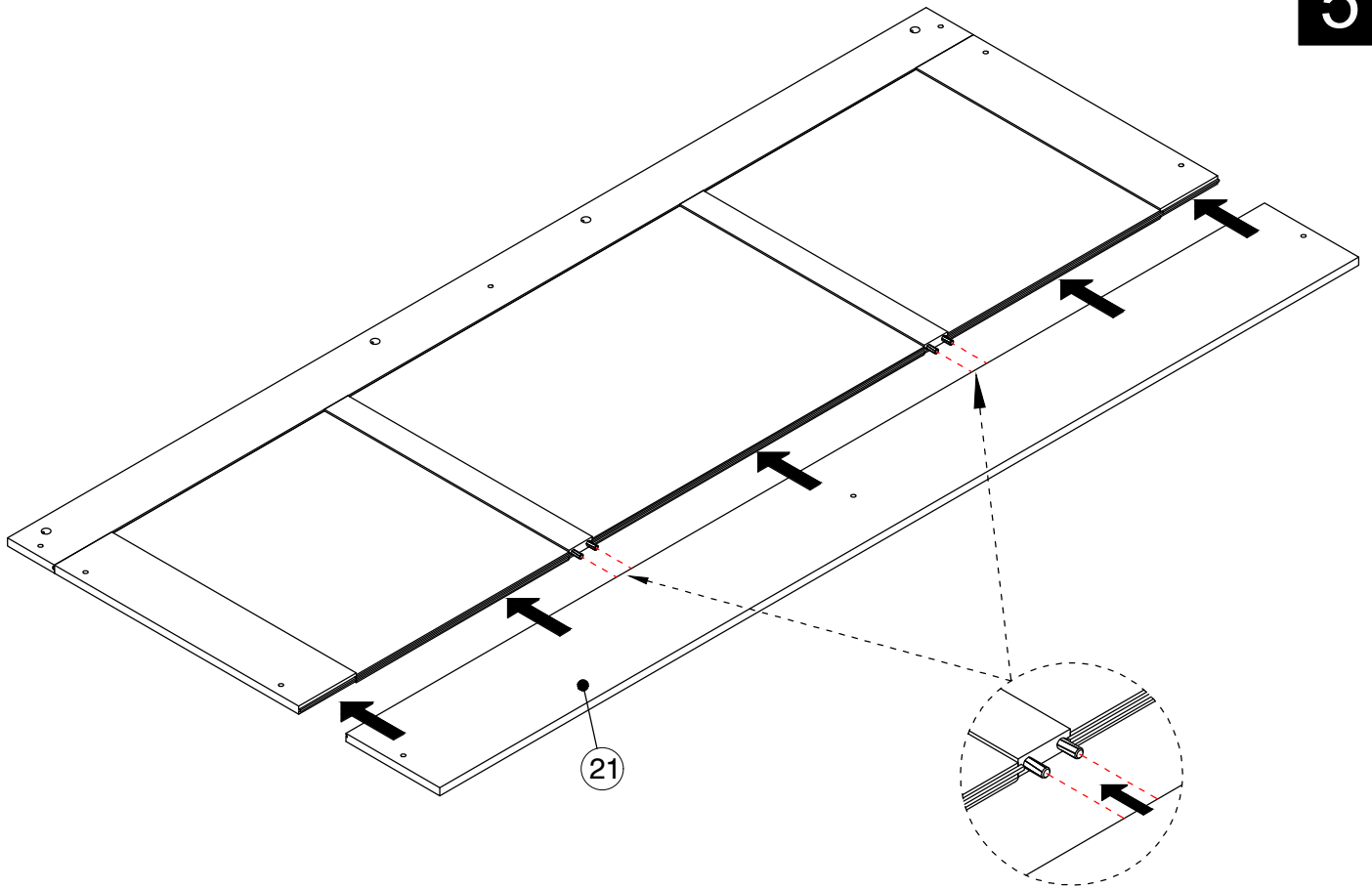

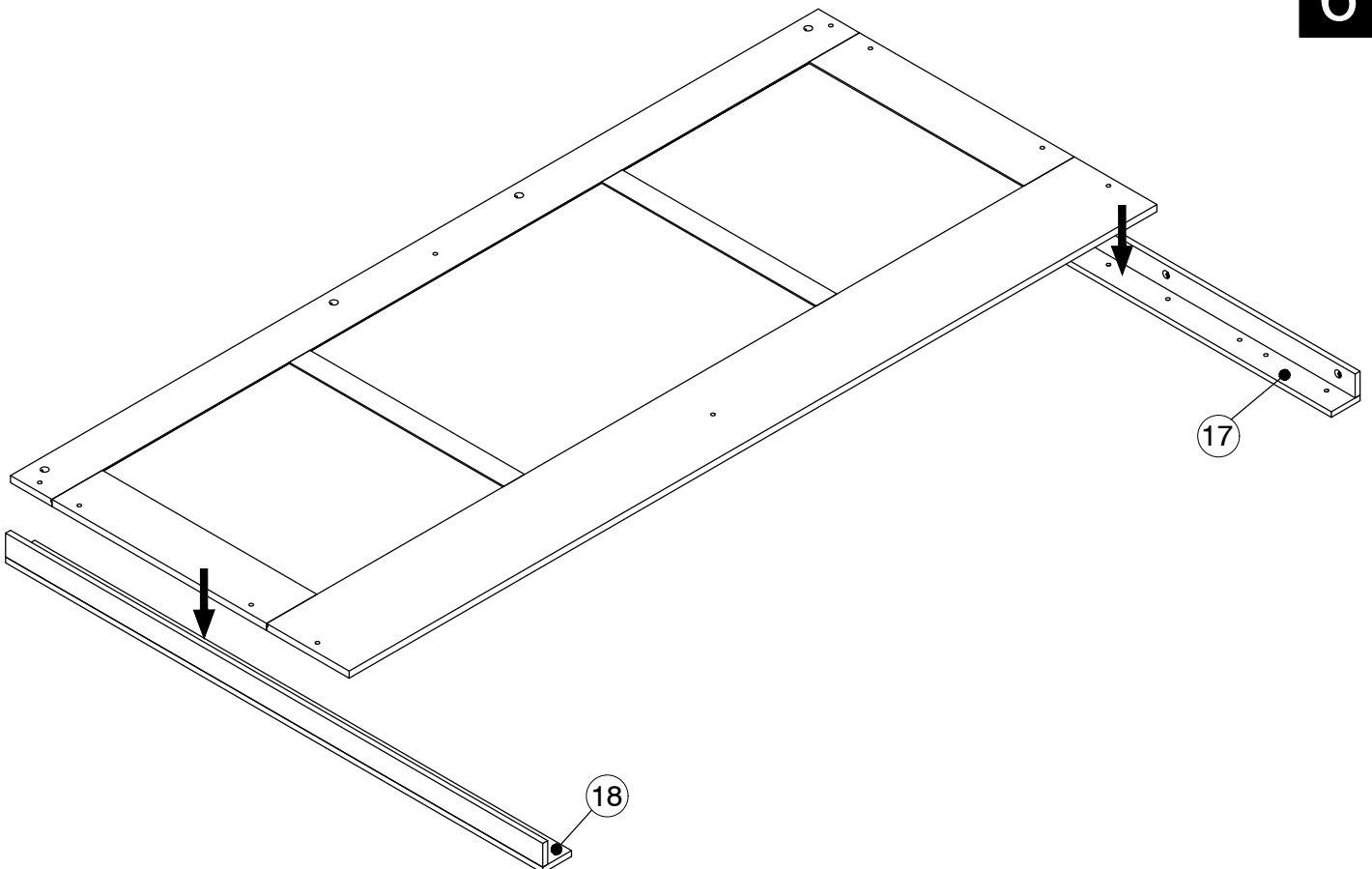

6



ASSEMBLY INSTRUCTIONS

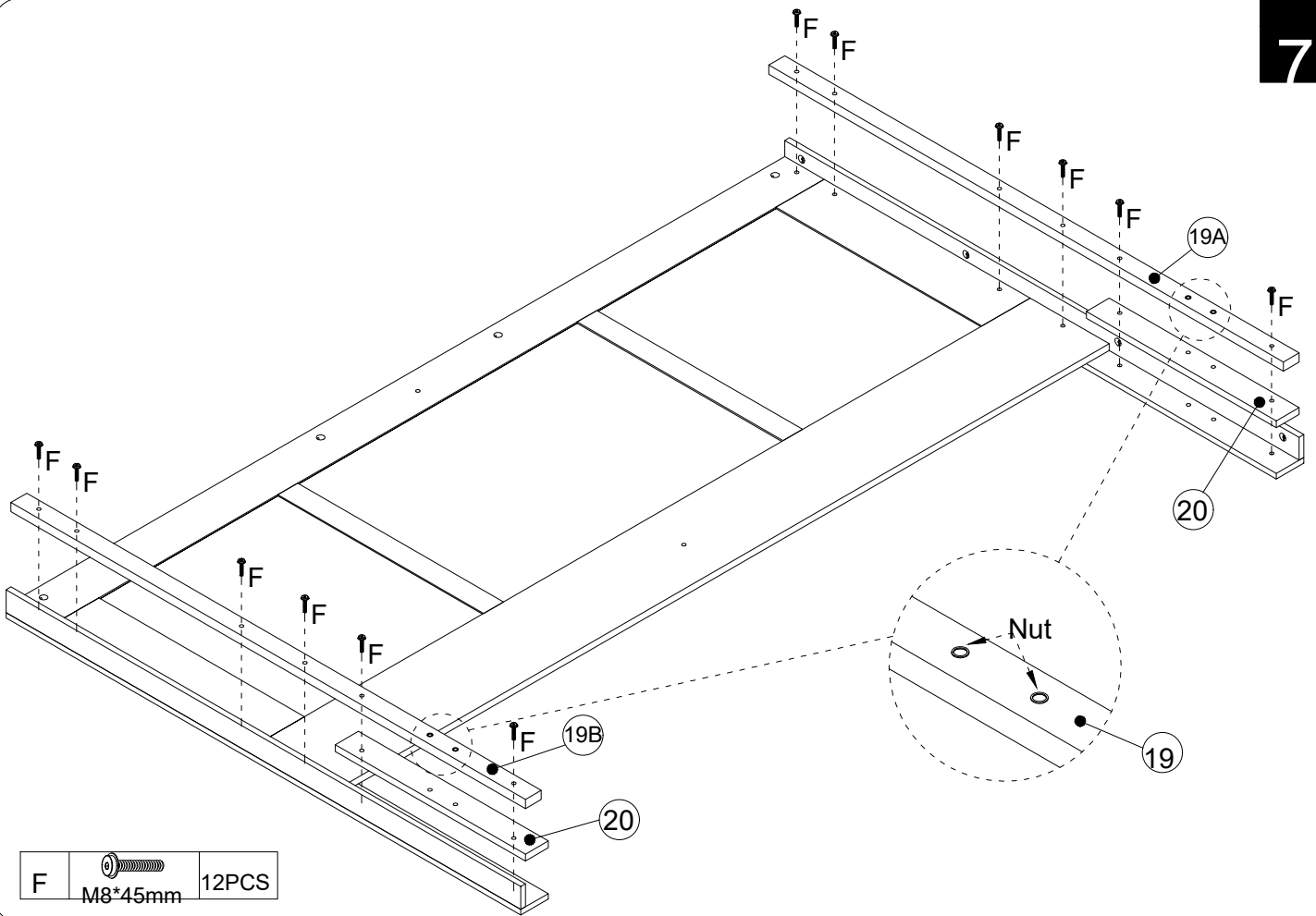

7

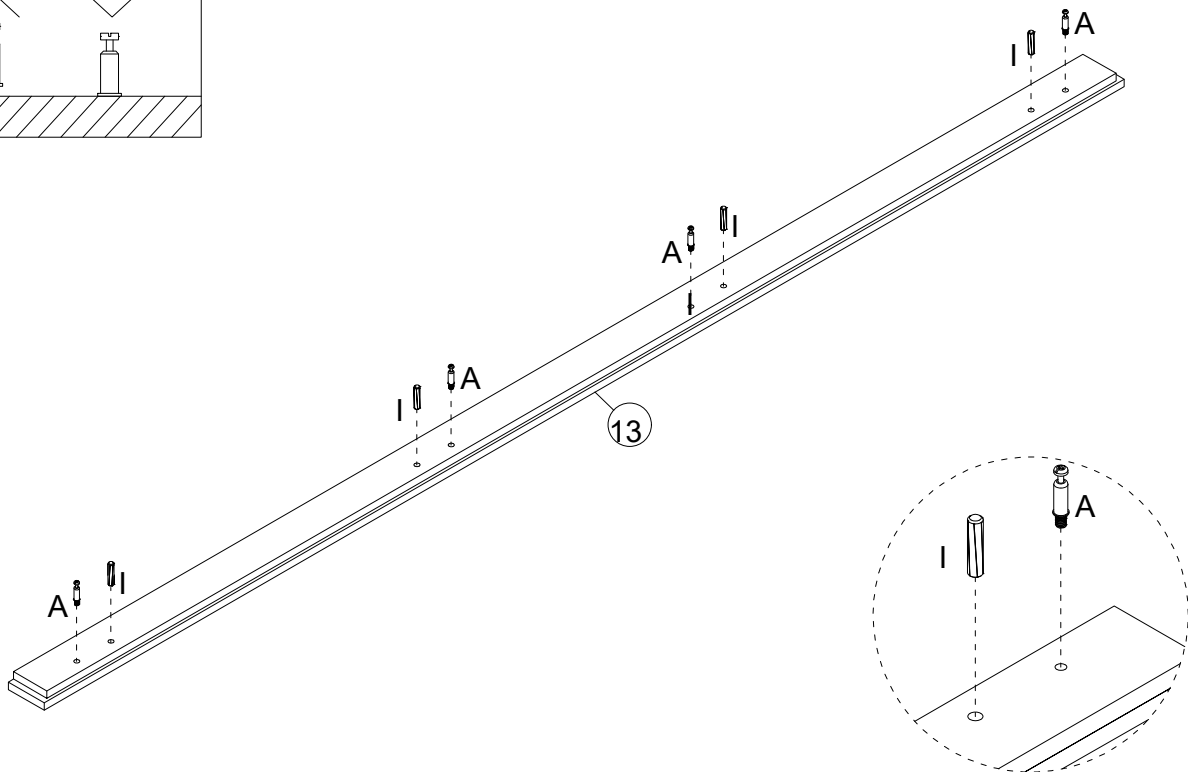
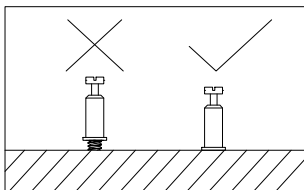

F		12PCS
M8*45mm		

8



A		4PCS
I		4PCS
Ø6*30mm		

ASSEMBLY INSTRUCTIONS

9

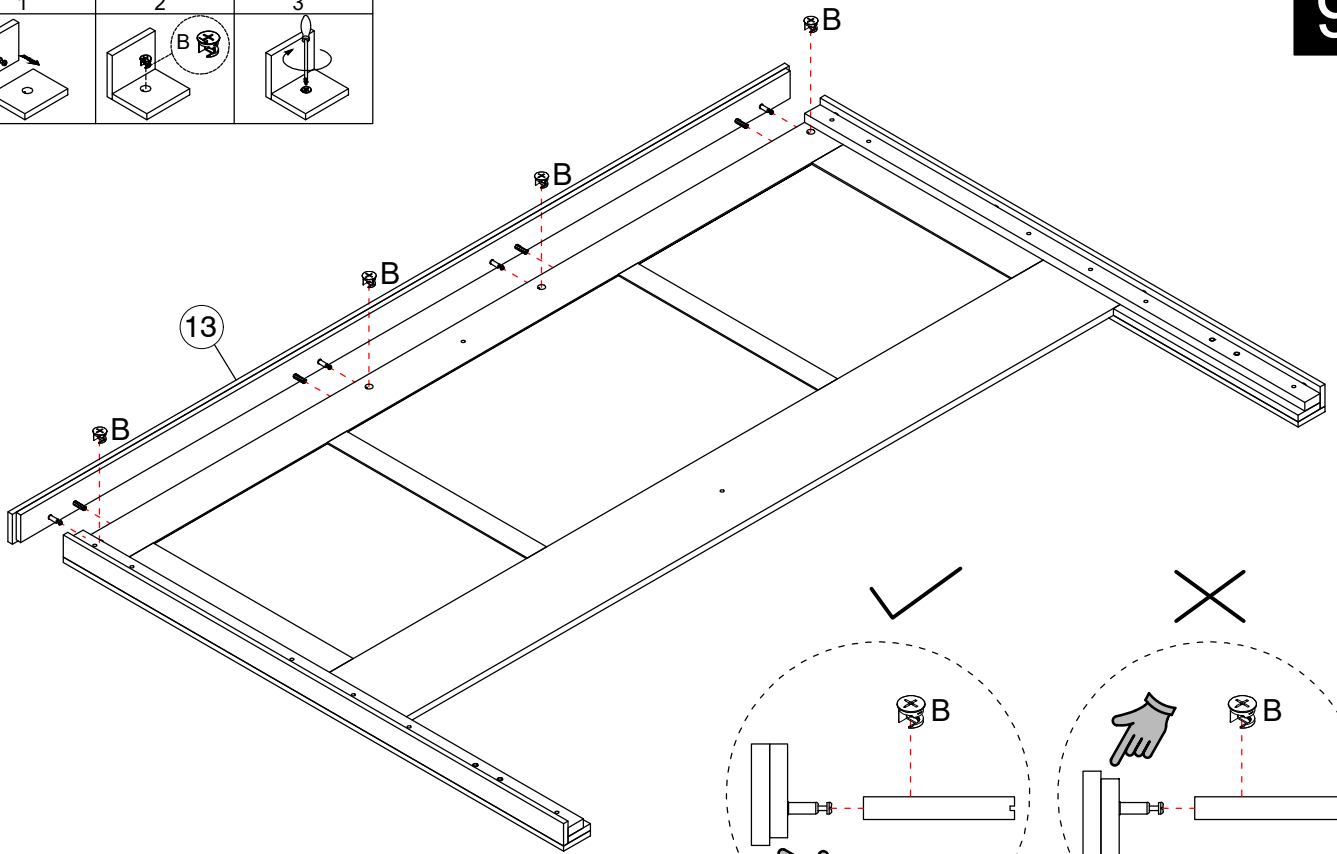
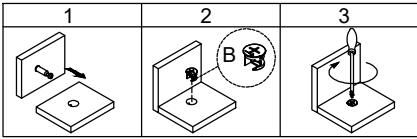

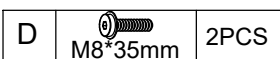
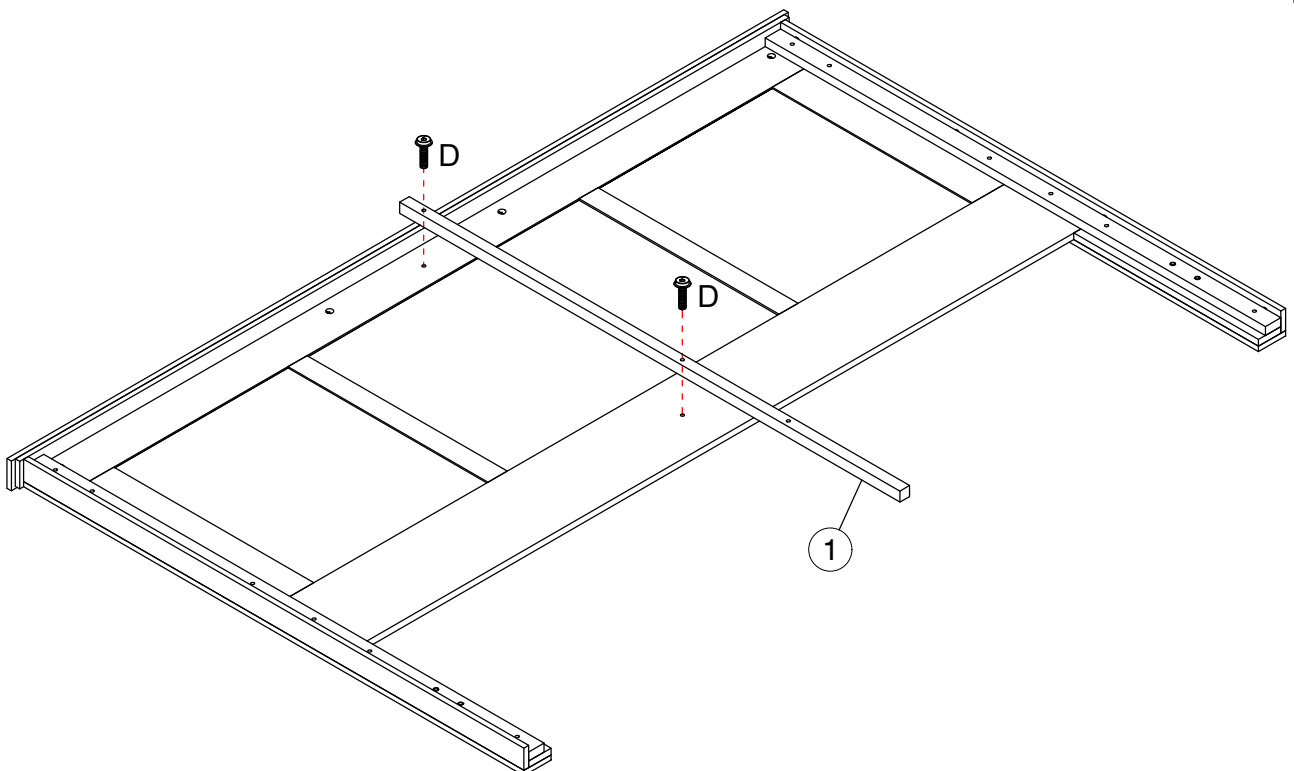

10

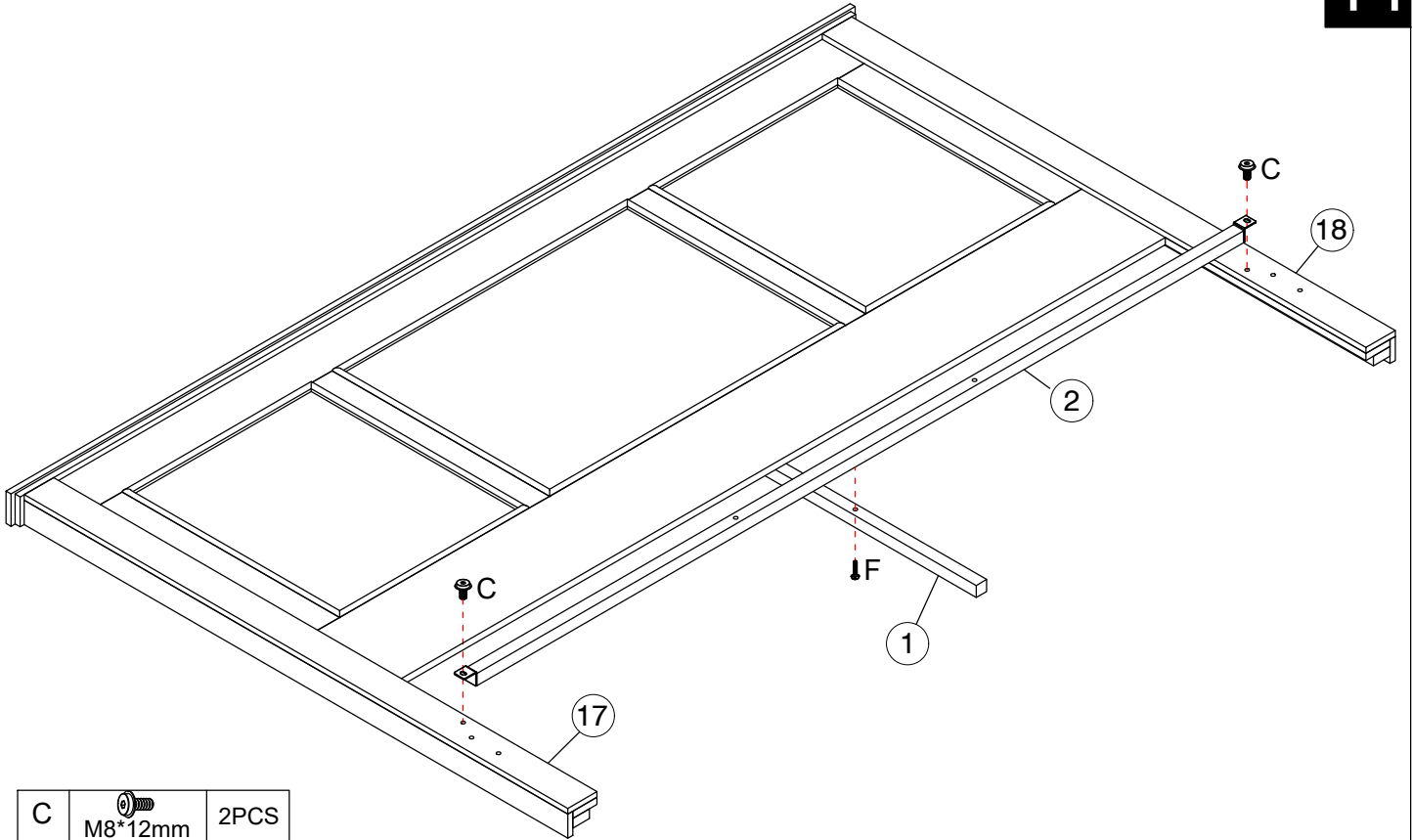

ASSEMBLY INSTRUCTIONS

11



C	 M8*12mm	2PCS
F	 M8*45mm	1PC

12

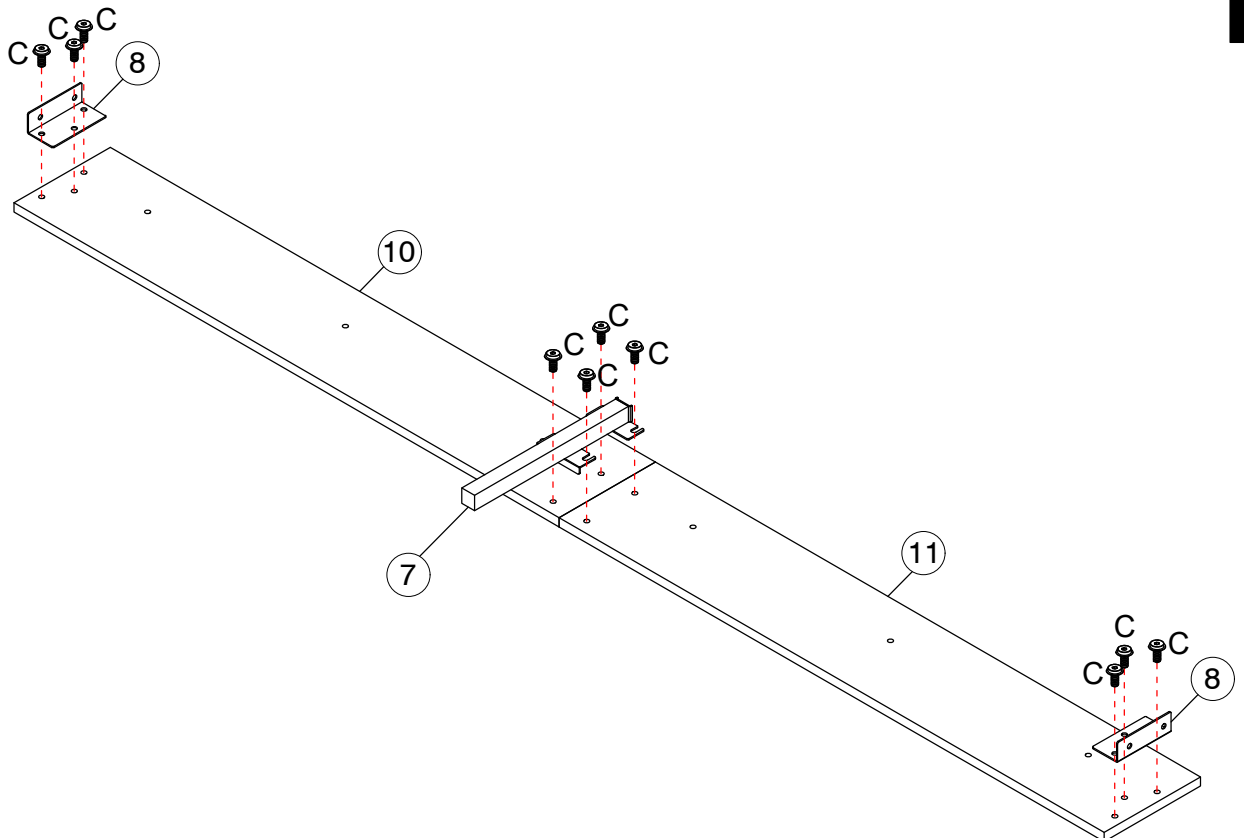



C	 M8*12mm	20PCS
---	---	-------

x2

ASSEMBLY INSTRUCTIONS

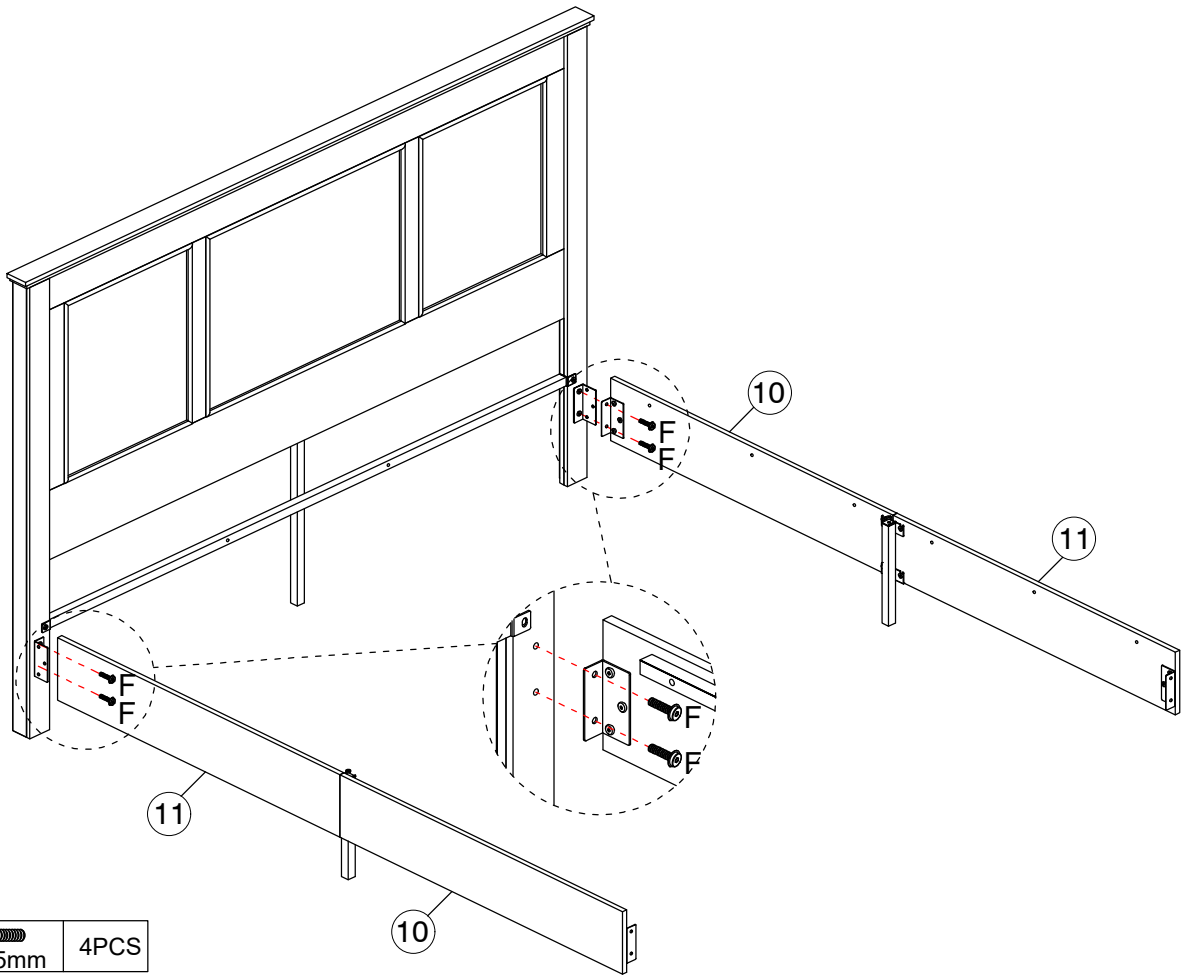
13



F  M8*45mm 4PCS

14

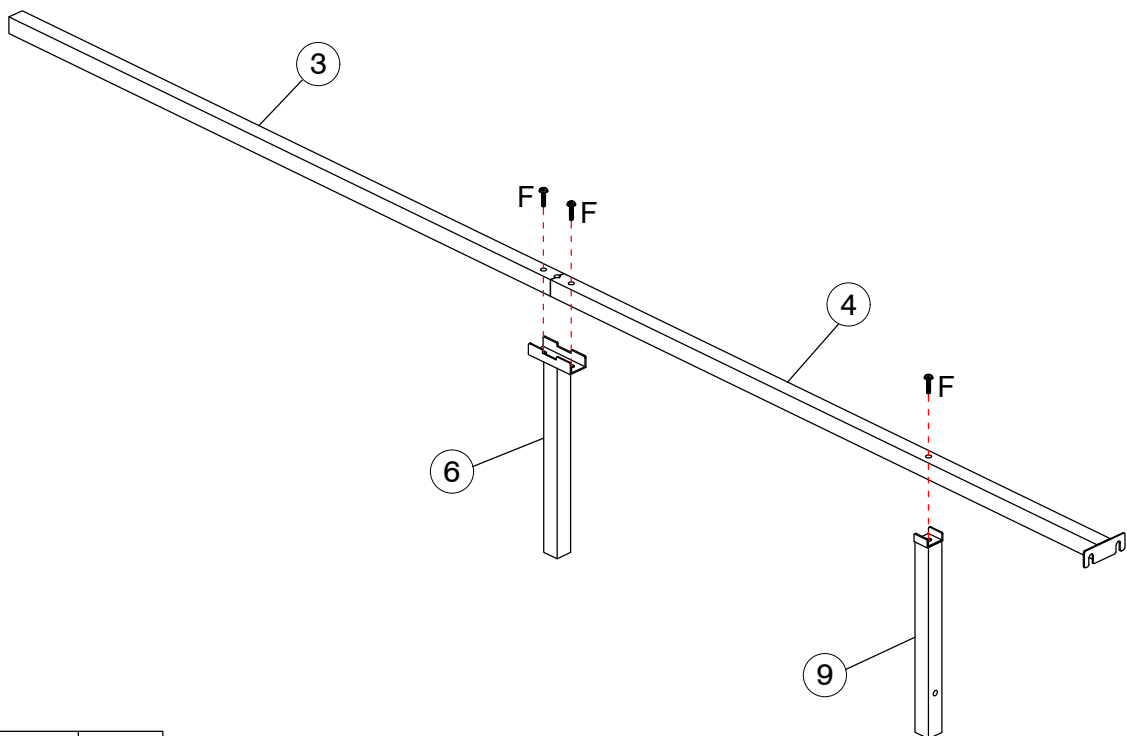



F  M8*45mm 6PCS

x2

ASSEMBLY INSTRUCTIONS

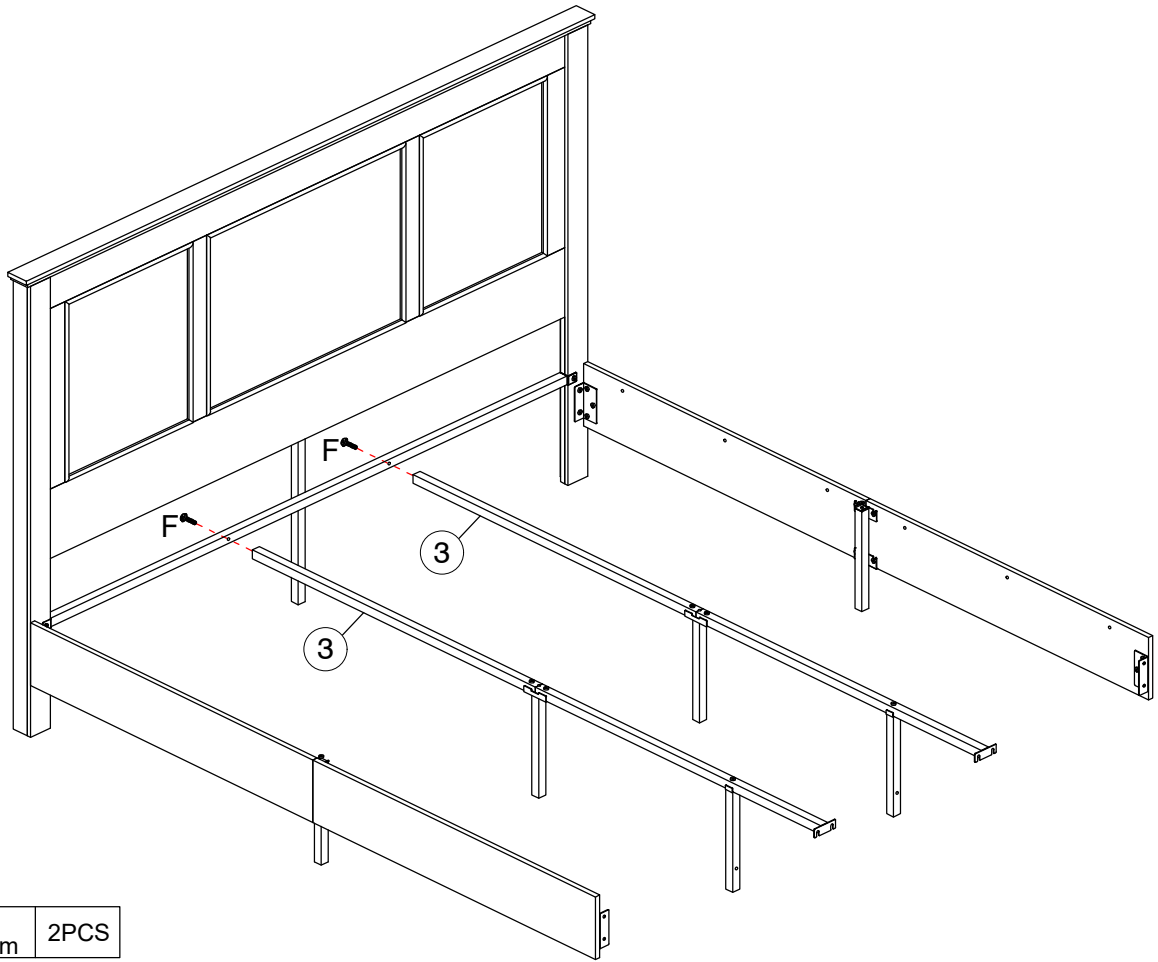

15

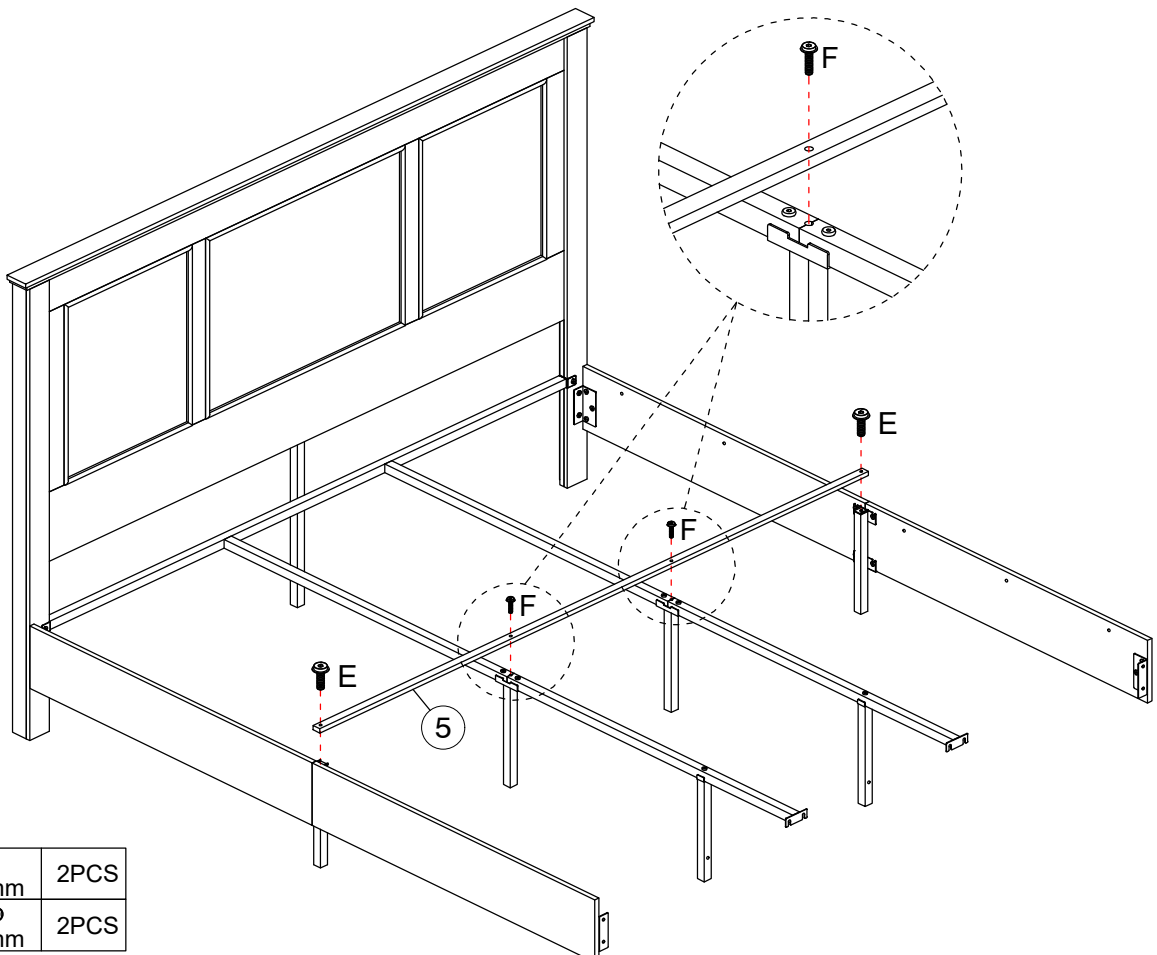

F		2PCS
---	---	------

16



E		2PCS
F		2PCS

ASSEMBLY INSTRUCTIONS

17

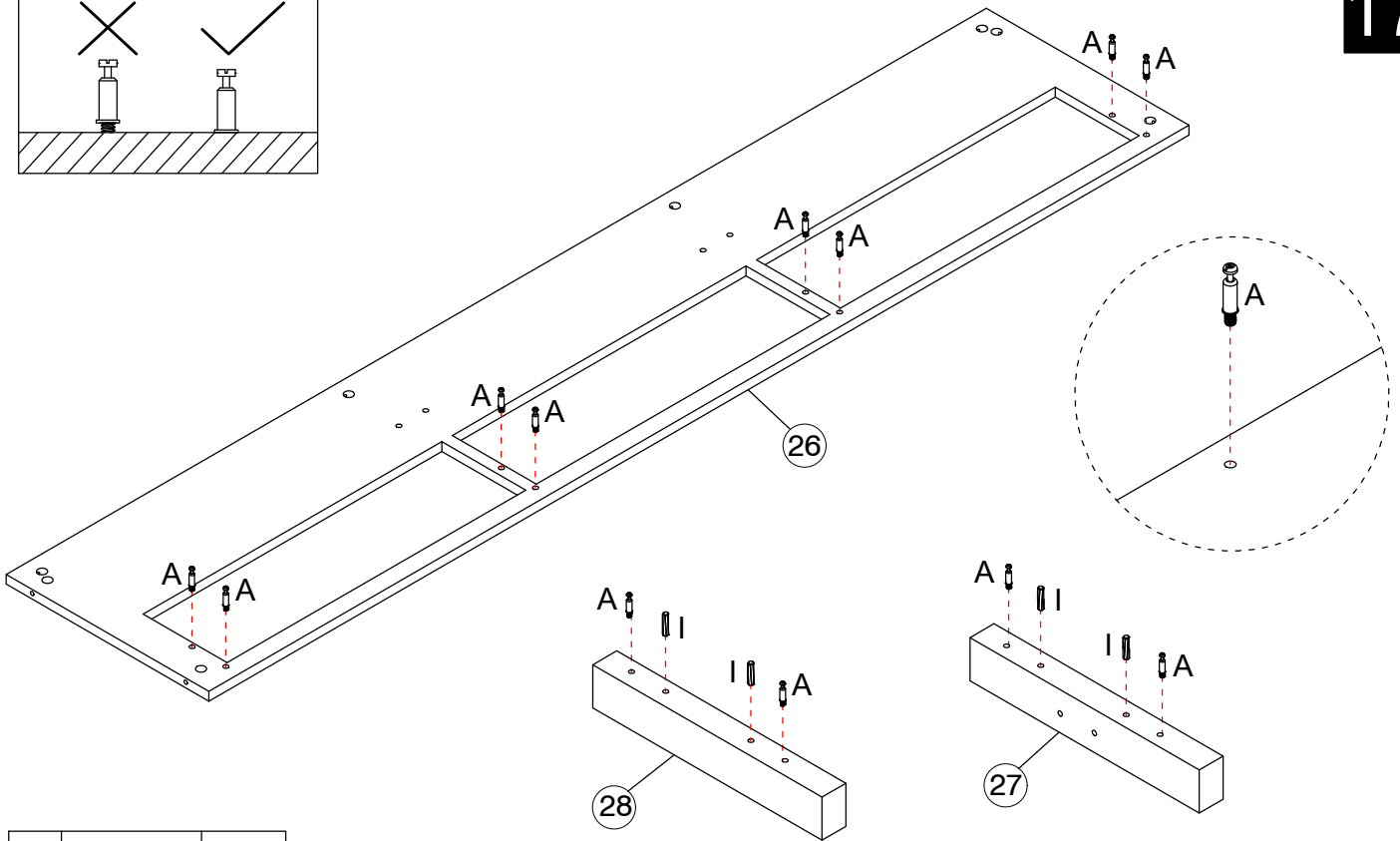
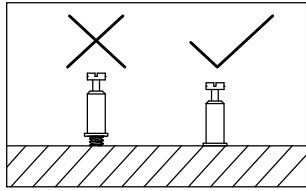

A		10PCS
I		4PCS

18

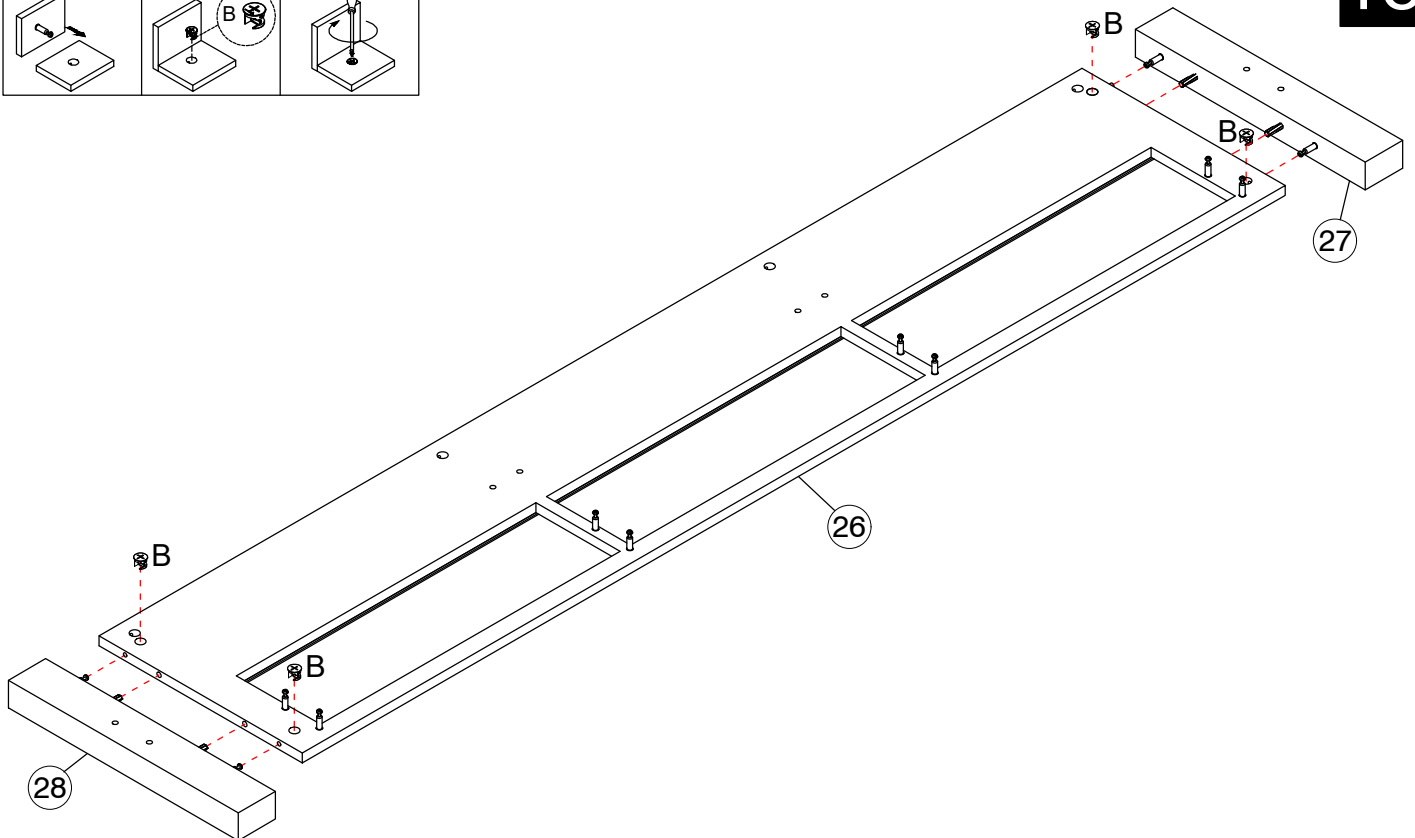
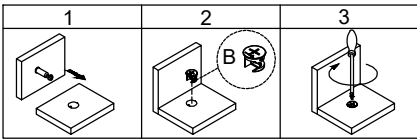

B		4PCS
---	--	------

ASSEMBLY INSTRUCTIONS

19

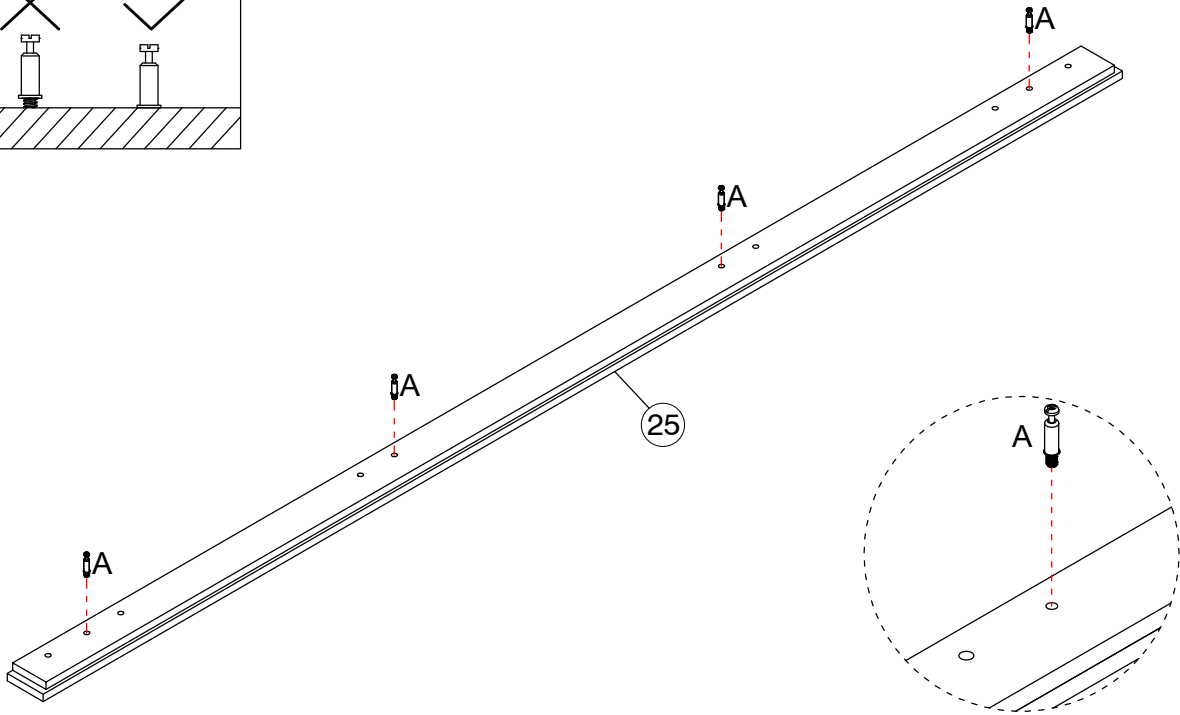
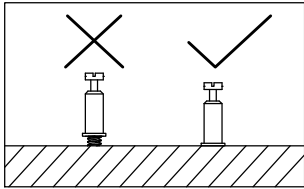

A		4PCS
---	--	------

20

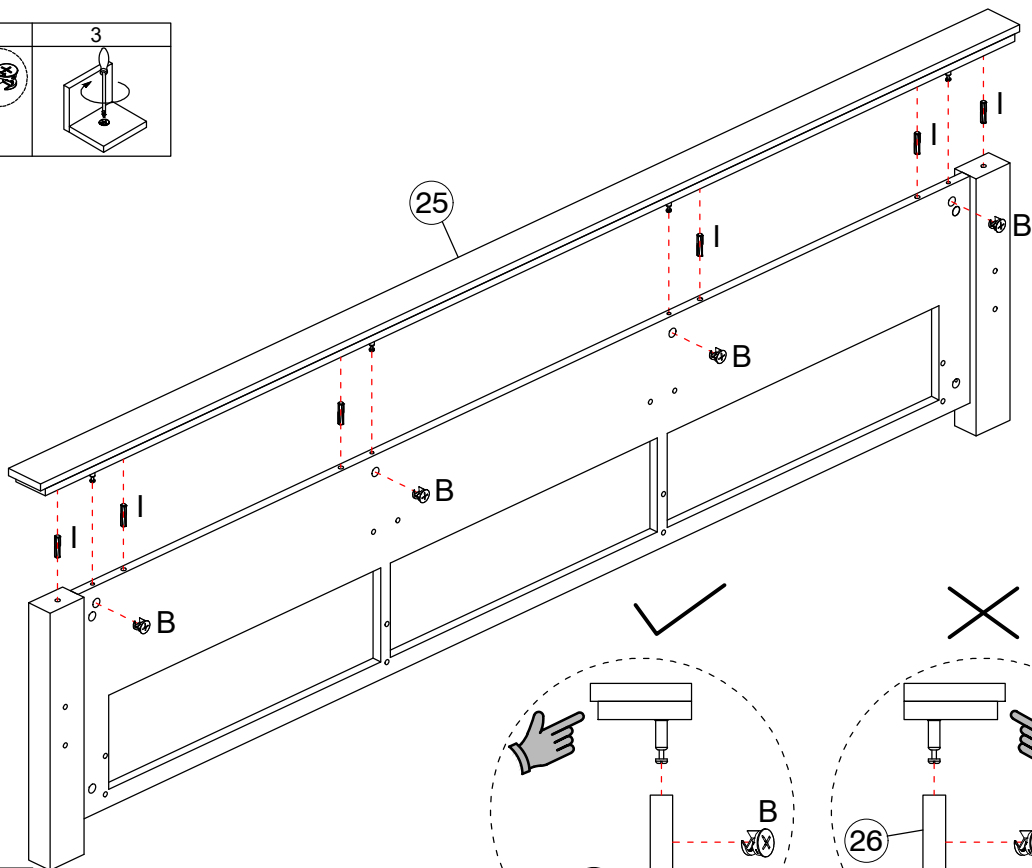
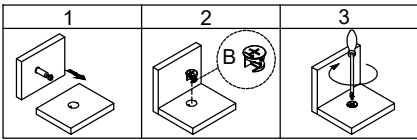

B		4PCS
I		6PCS

ASSEMBLY INSTRUCTIONS

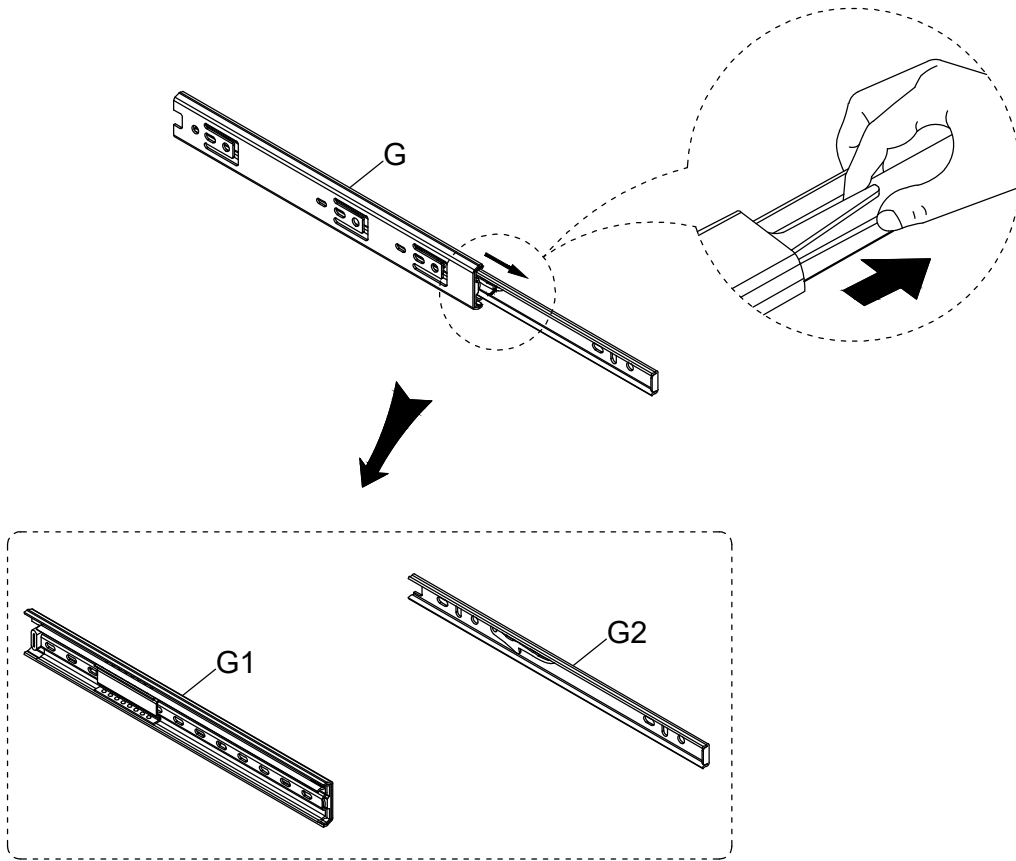

21

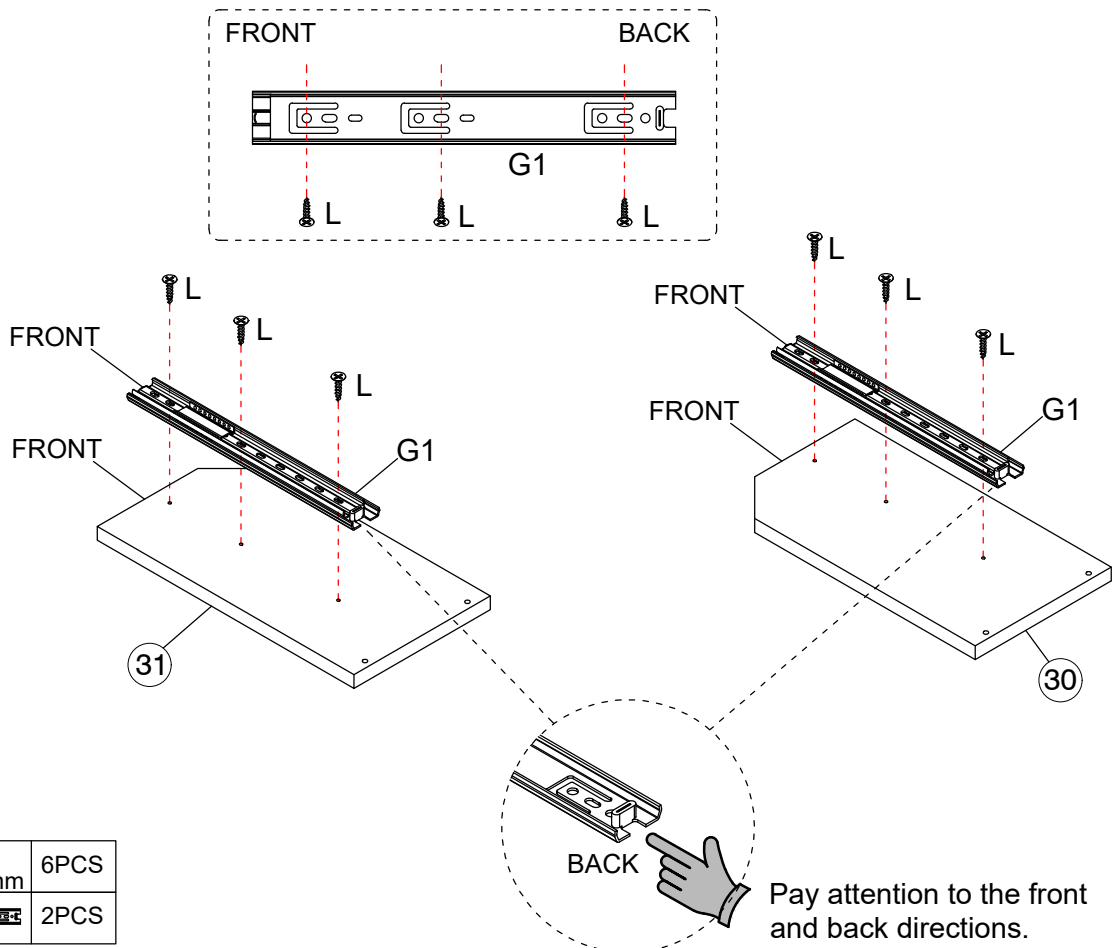

x6

22





L	 Ø3.5*15mm	6PCS
G1		2PCS

Pay attention to the front and back directions.

ASSEMBLY INSTRUCTIONS

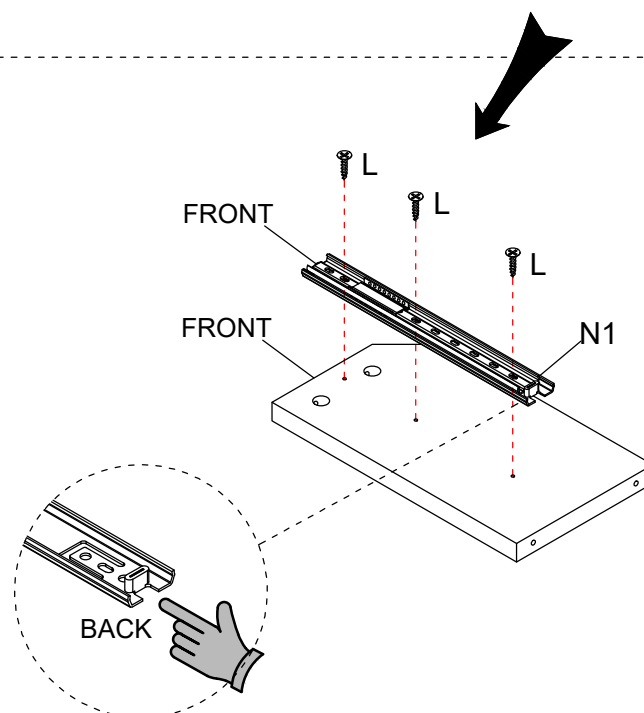
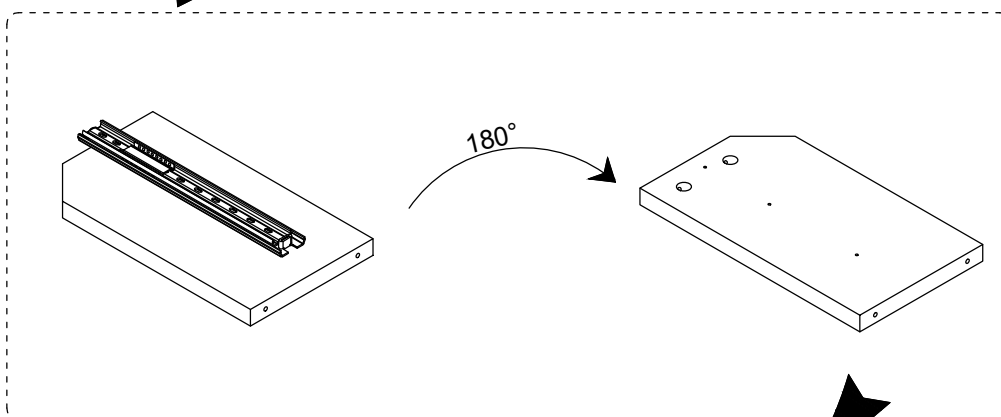
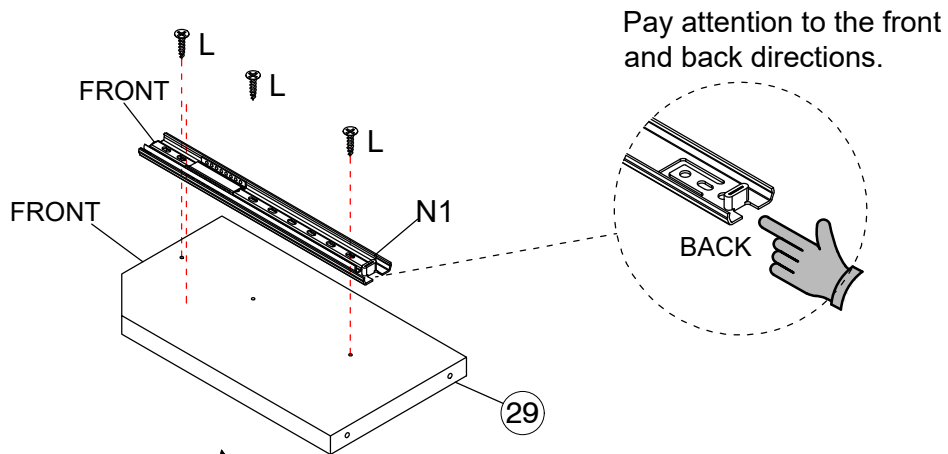
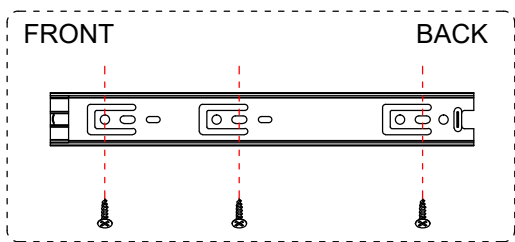
23



L	 Ø3.5*15mm	6PCS
N1		2PCS

x2

ASSEMBLY INSTRUCTIONS

24

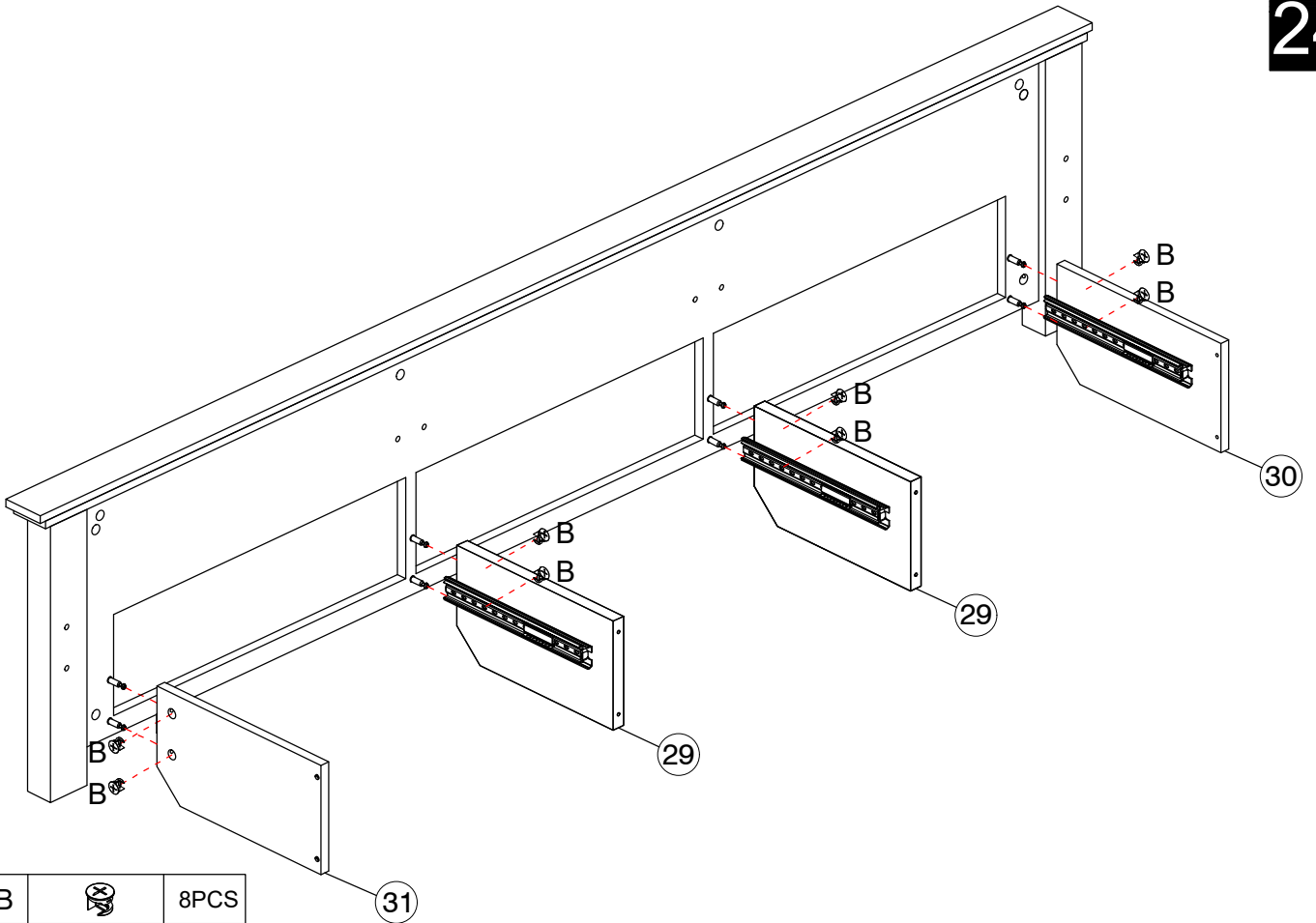

25

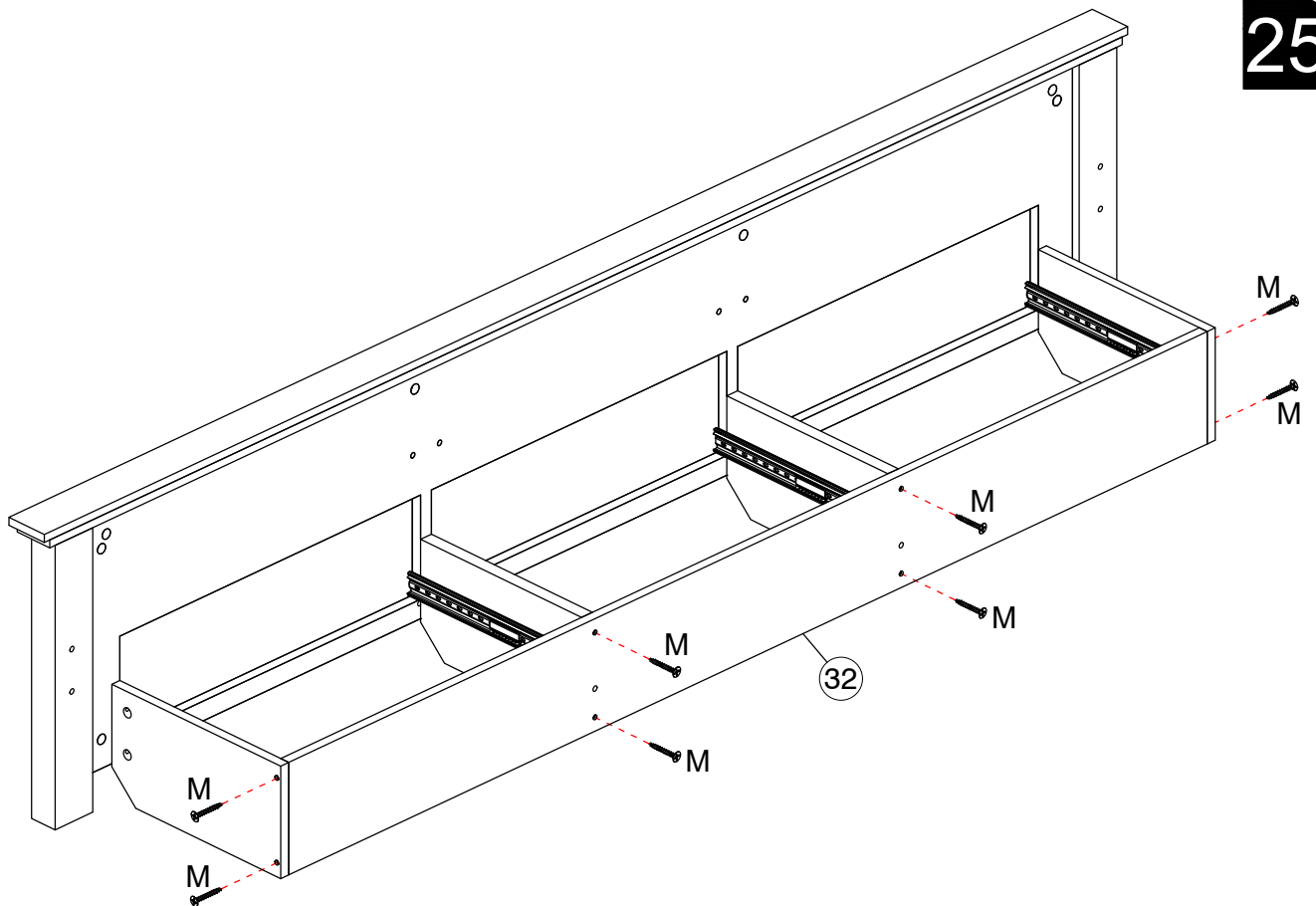

ASSEMBLY INSTRUCTIONS

26

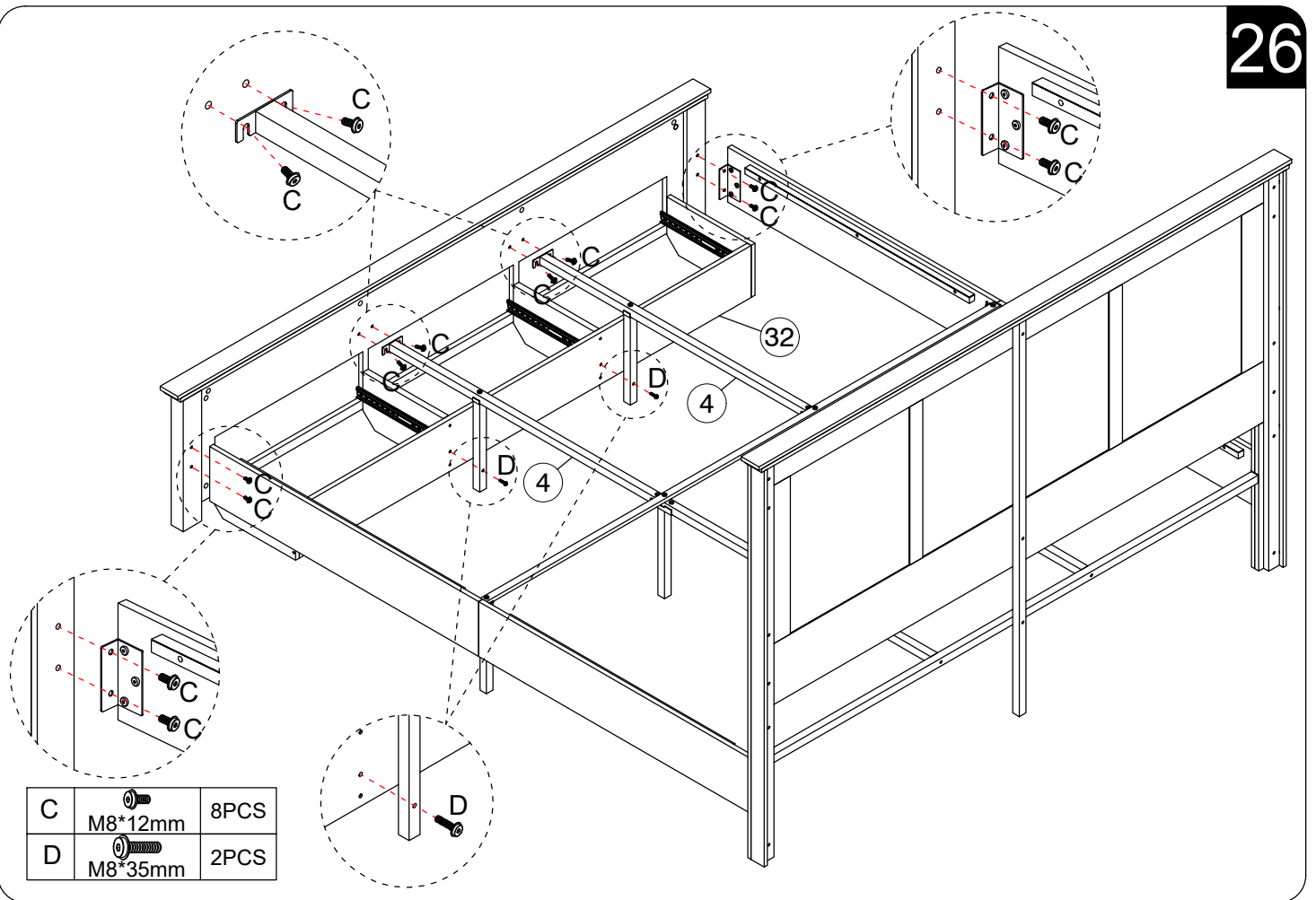

27

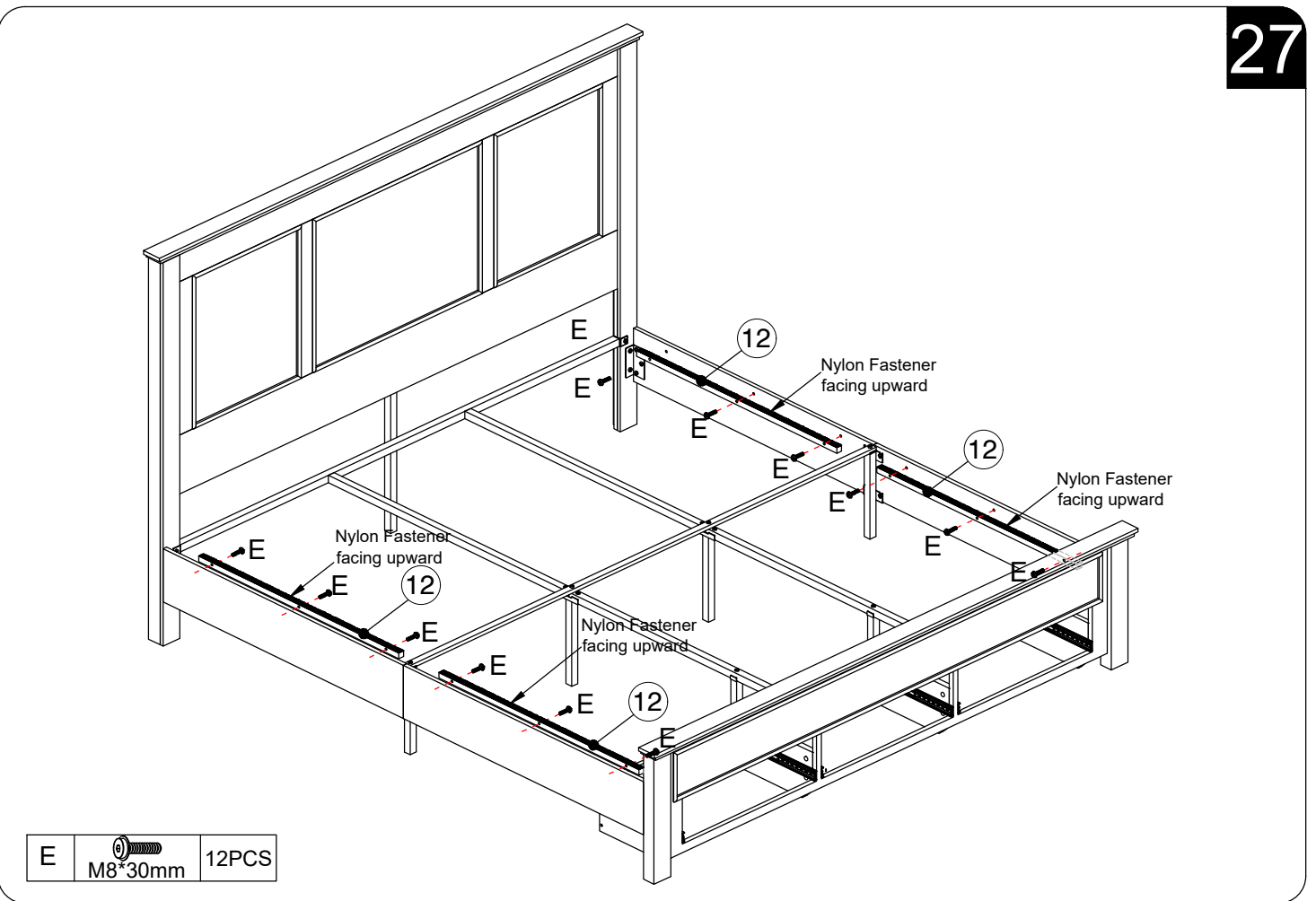

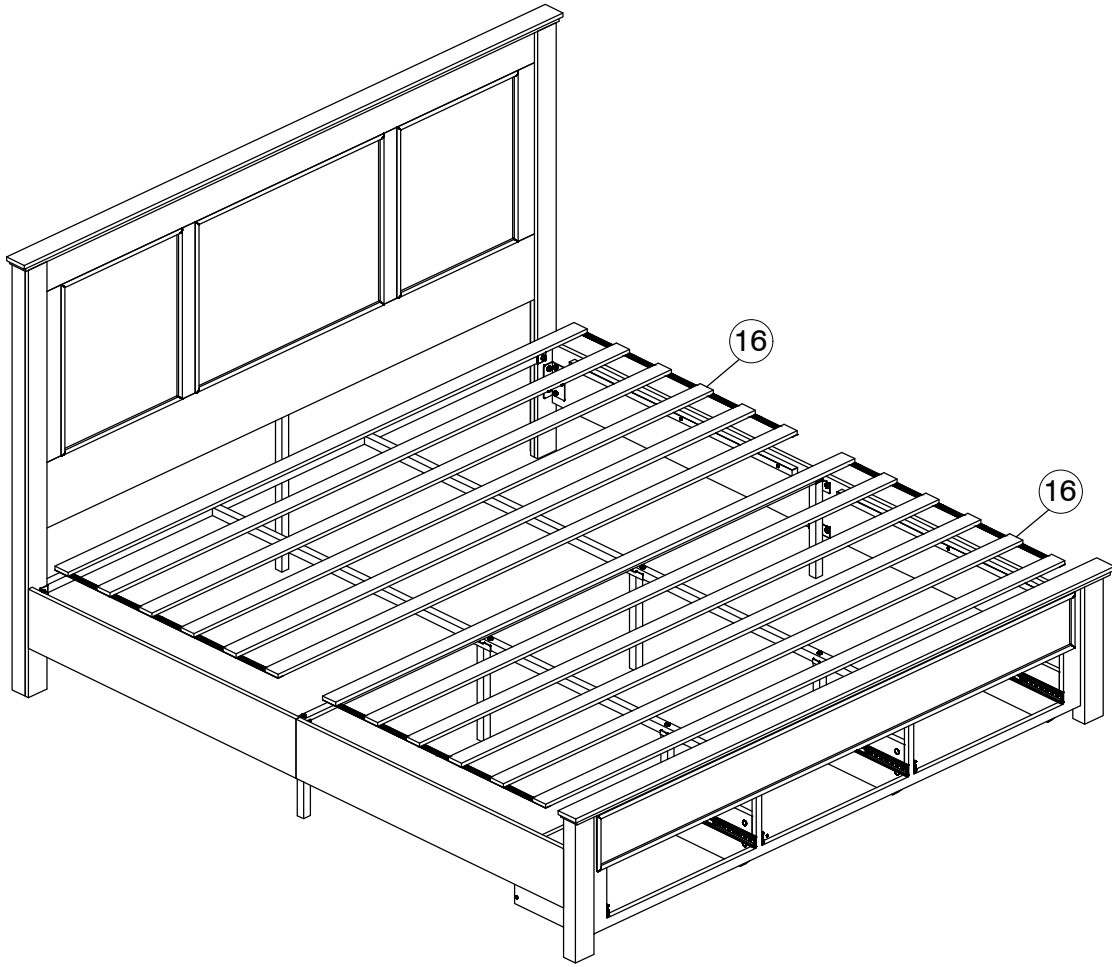

ASSEMBLY INSTRUCTIONS

28

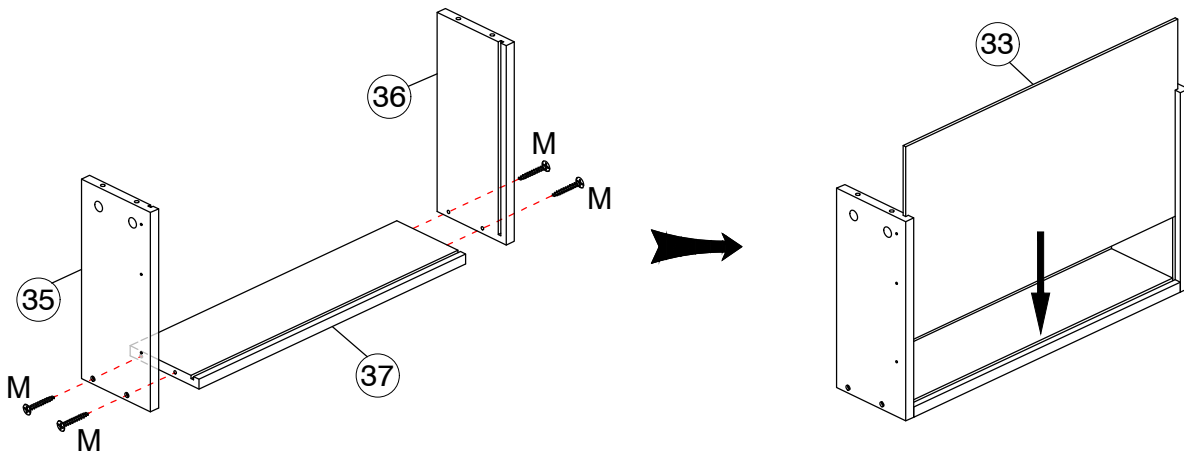
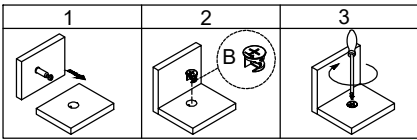

29



M		12PCS
---	---	-------

Ø4*30mm

x3

ASSEMBLY INSTRUCTIONS

30

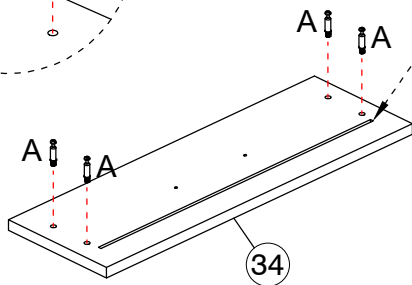
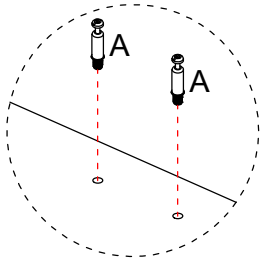
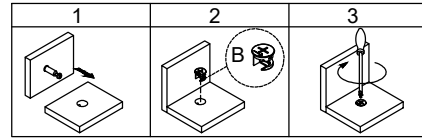
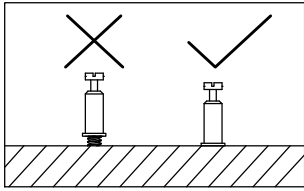

When installing, make sure the groove on part 34 aligns with part 33.

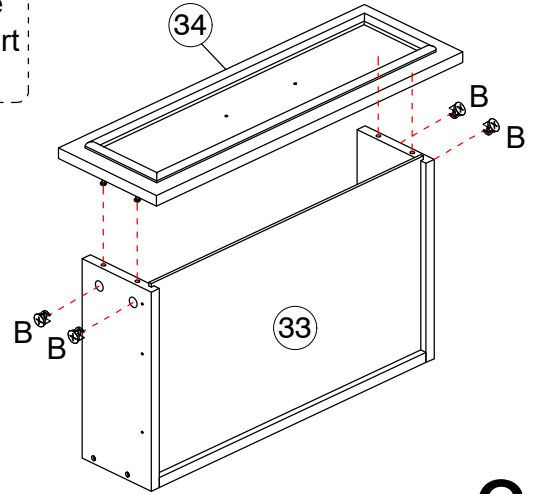

x3

A		12PCS
B		12PCS

31

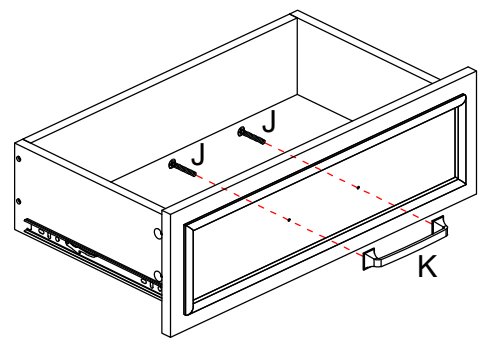
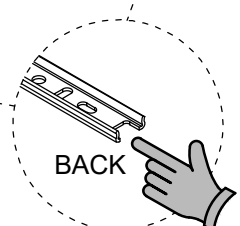
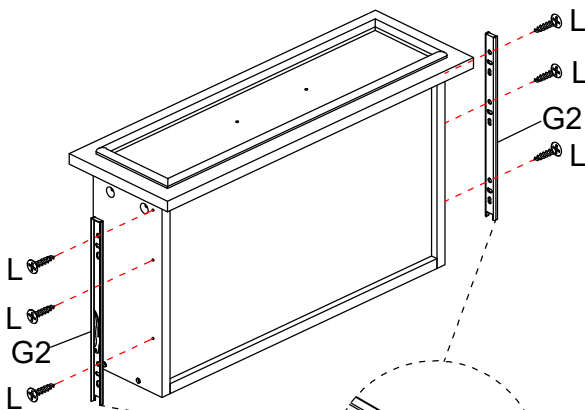
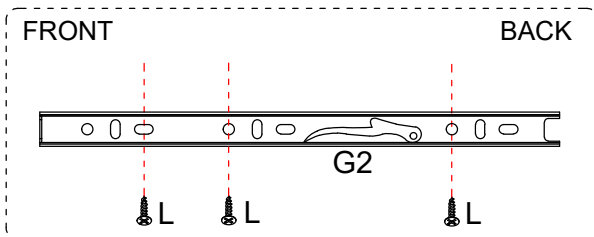

x3

L		18PCS
G2		6PCS

J		6PCS
K		3PCS

Try to find a partner to install with you, which can speed up the installation efficiency and shorten the time.

Please make sure that the balls in the tracks on both sides are pulled to the top, and then insert the tracks to ensure smooth entry.

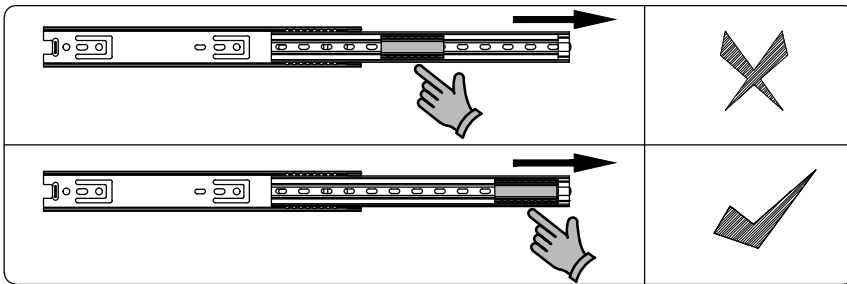

1. Drawers must be horizontally put into the cabinets.
2. Make sure both sides sliders match well to avoid damage.

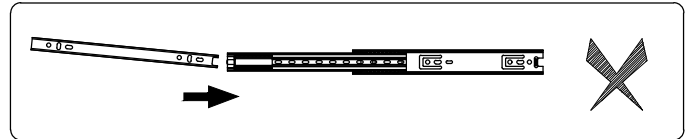
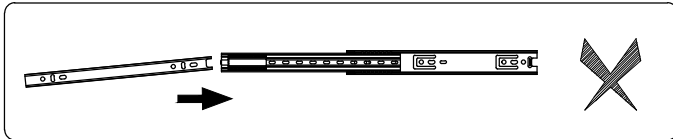
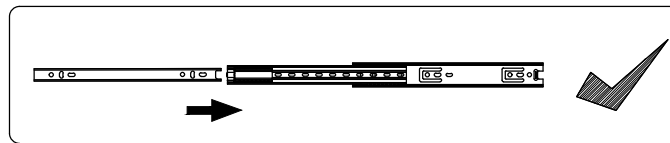

Attention:

1. Pull out the rail installed on the cabinet.
 2. Align the slide runners on the drawer with the unit and push it carefully inside until it stops.
- * If the drawer does not go in smoothly, please take it out and repeat the steps.

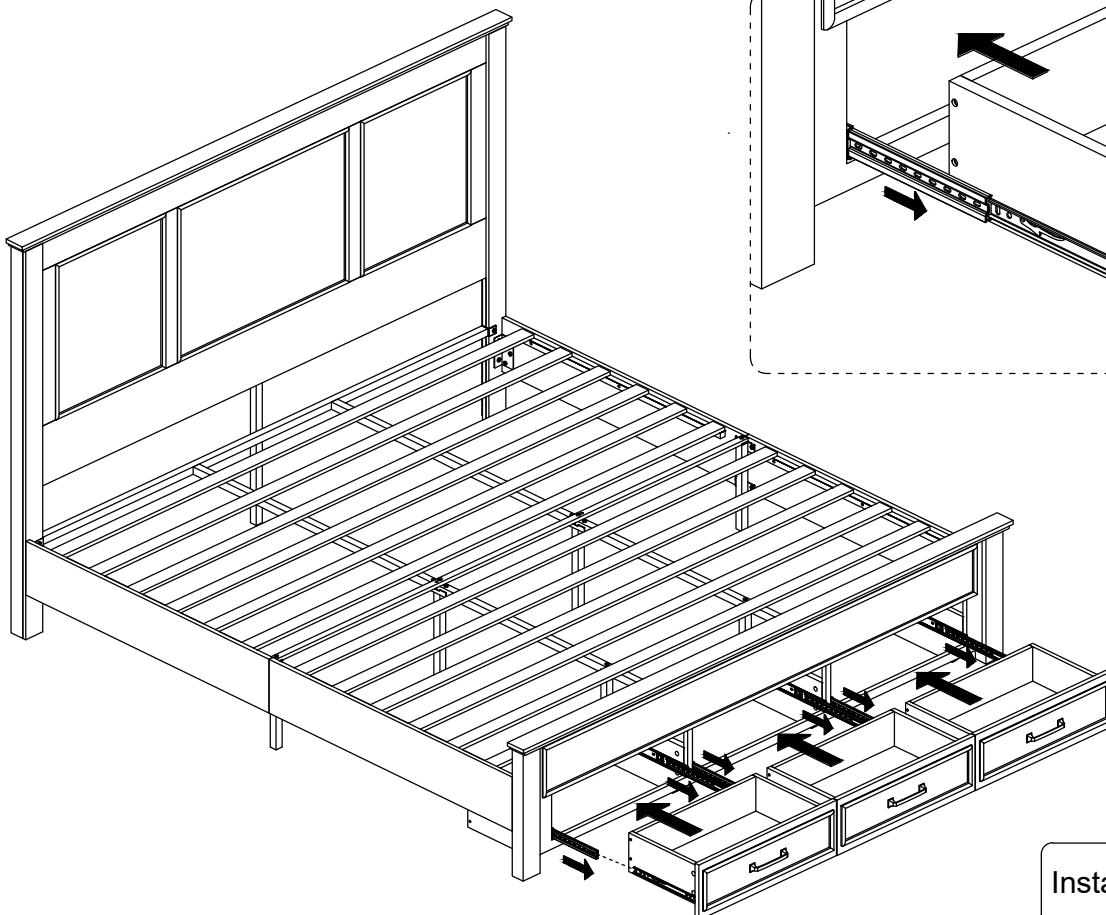

Installation Complete