

# Assembly Instructions

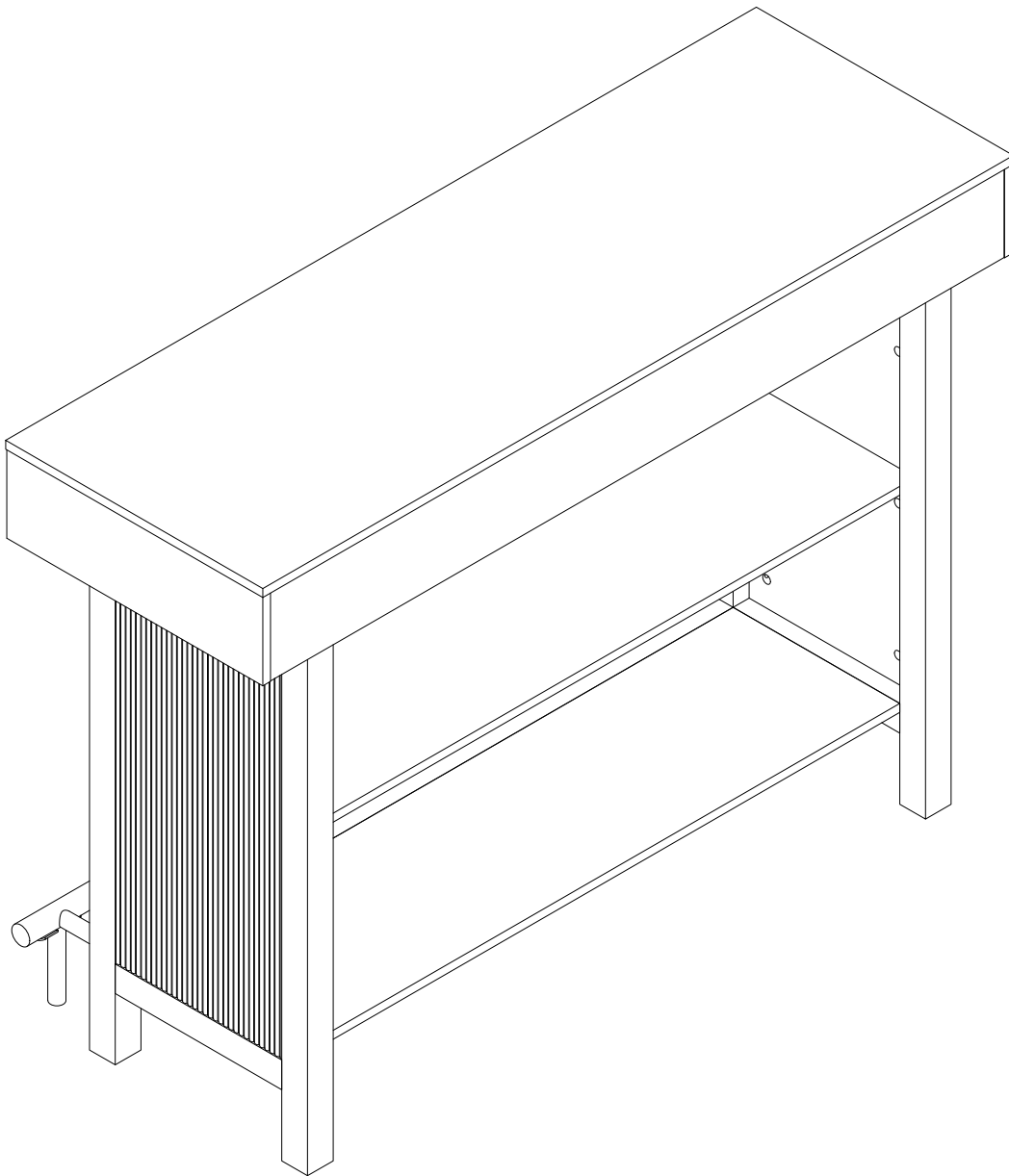

---

Bar Table

---

# Contact Us

## We're here to help you.

Your satisfaction is our top priority. If you encounter any issues with this product, such as missing or damaged parts, we're here to help. Please retain the original packaging and take photos of the packaging and the product, then contact us as soon as possible.

### Warm Tips

1. Carefully read these instructions and keep them for future reference.
2. Check the parts list and confirm everything's there before starting assembly.
3. When assembling, put all parts on a soft, smooth surface like a carpet to avoid scratches.
4. Don't fully tighten screws until all parts are confirmed in place to avoid misalignment.

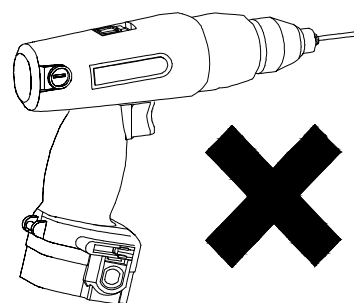
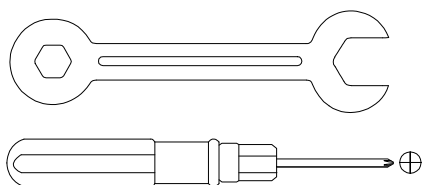
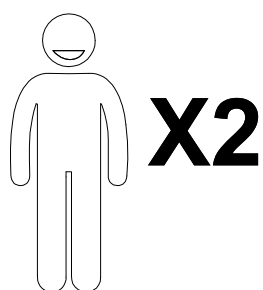

We recommend using hand tools for assembly.

If an electric screwdriver is used, reduce power and torque to avoid damage to the product.

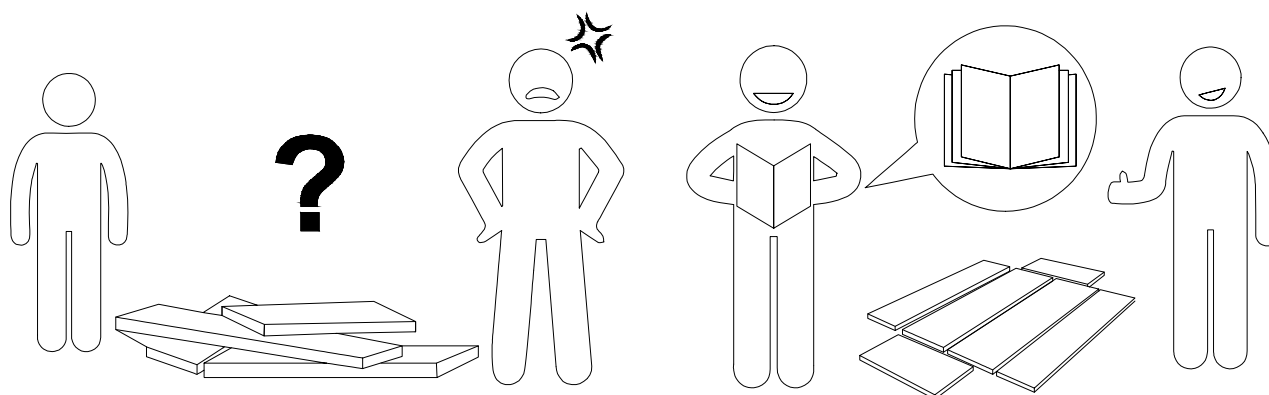

## AVOID SCRATCHES

In order to avoid scratching, this furniture should be assembled on a soft surface, such as a rug.

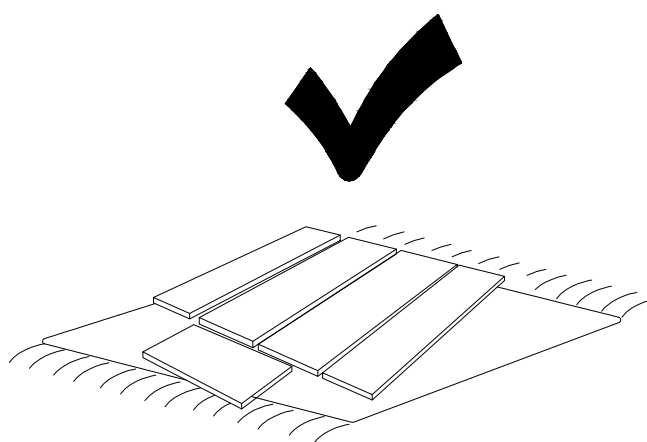
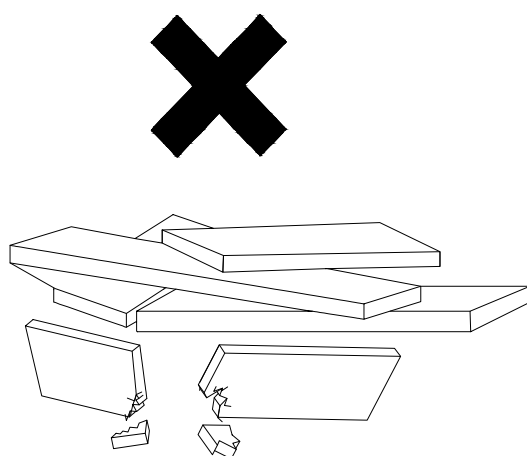

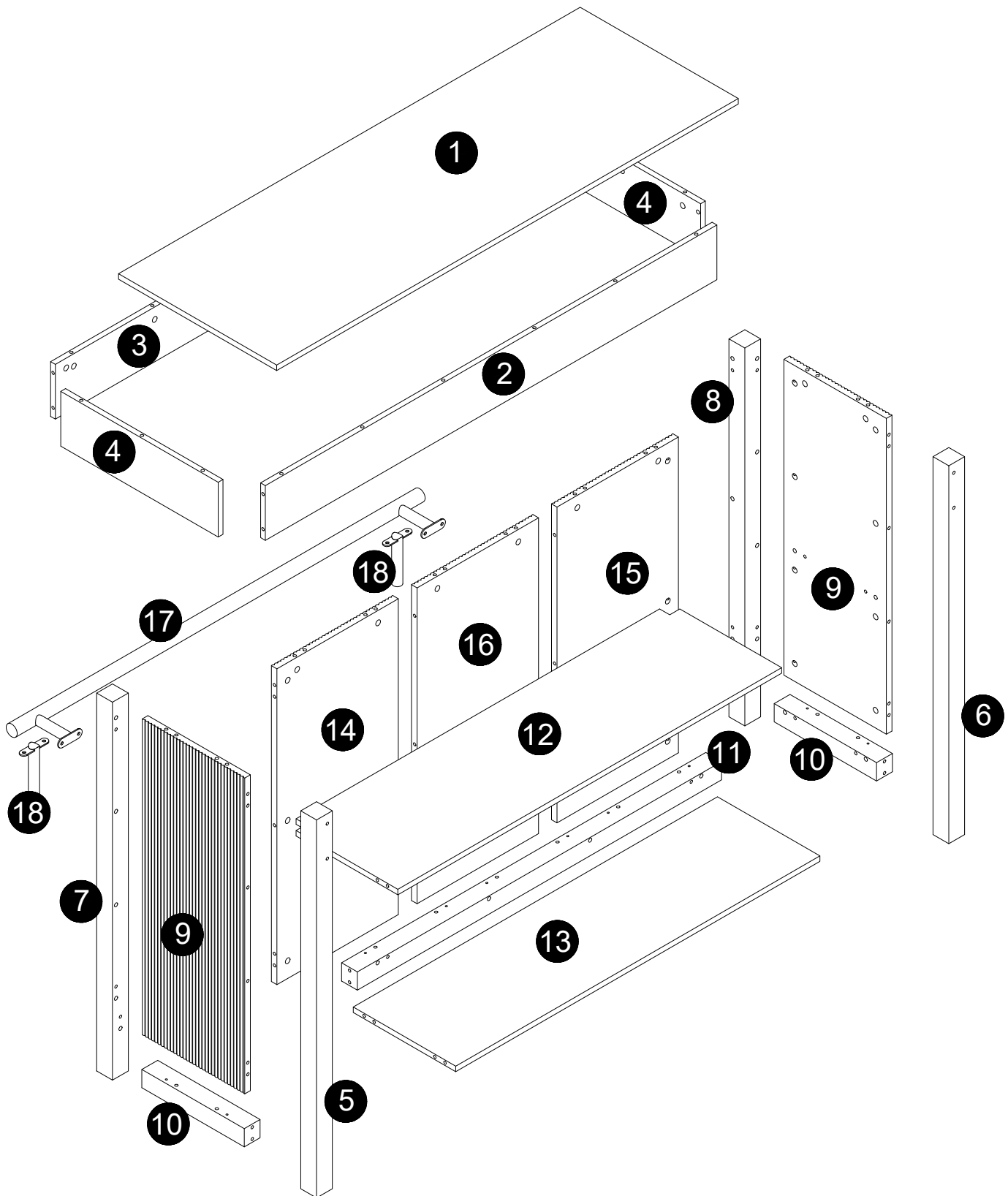





**⚠ Caution**

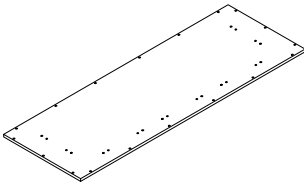
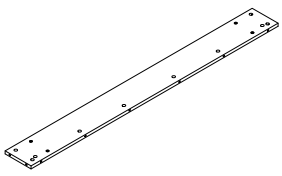
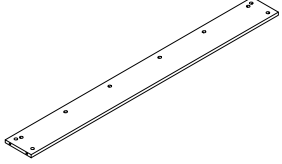
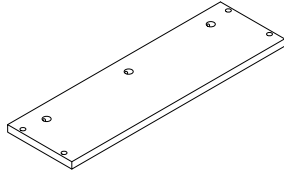
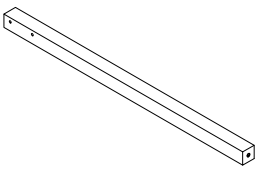
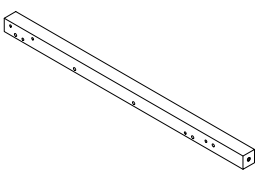
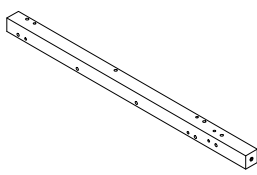
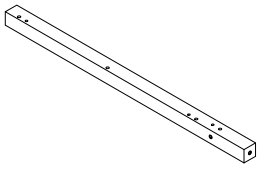
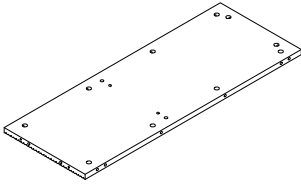
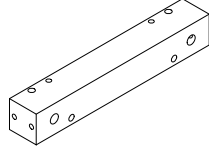
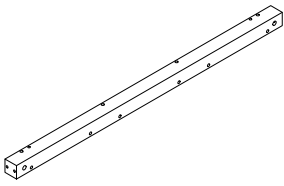
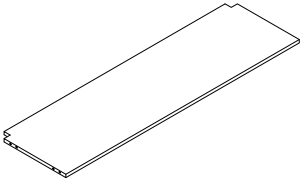
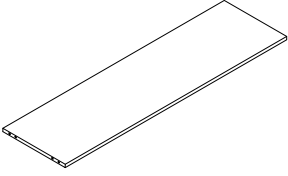
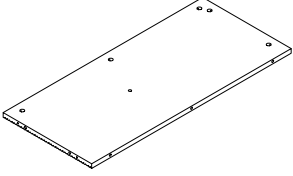
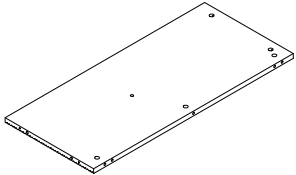
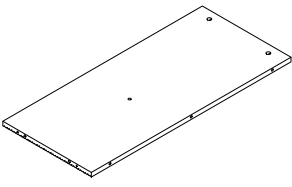
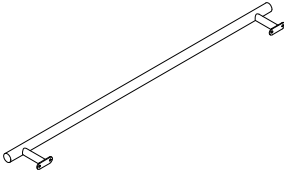

Make sure all parts are included. Most board parts are labeled or stamped on the raw edge. Contact us for a free replacement if you encounter any damaged or missing parts.

# Parts List

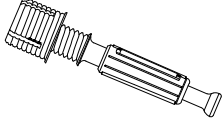
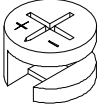
<p><b>1</b></p>  <p>1pc</p>	<p><b>2</b></p>  <p>1pc</p>	<p><b>3</b></p>  <p>1pc</p>	<p><b>4</b></p>  <p>2 pcs</p>
<p><b>5</b></p>  <p>1pc</p>	<p><b>6</b></p>  <p>1pc</p>	<p><b>7</b></p>  <p>1pc</p>	<p><b>8</b></p>  <p>1pc</p>
<p><b>9</b></p>  <p>2 pcs</p>	<p><b>10</b></p>  <p>2 pcs</p>	<p><b>11</b></p>  <p>1pc</p>	<p><b>12</b></p>  <p>1pc</p>
<p><b>13</b></p>  <p>1pc</p>	<p><b>14</b></p>  <p>1pc</p>	<p><b>15</b></p>  <p>1pc</p>	<p><b>16</b></p>  <p>1pc</p>
<p><b>17</b></p>  <p>1pc</p>	<p><b>18</b></p>  <p>2 pcs</p>		

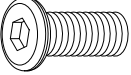
# Hardware List

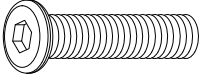
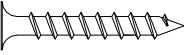
A	B	C	D
 <p data-bbox="219 536 393 571">Ø6x40mm</p>	 <p data-bbox="568 536 745 571">Ø15x12mm</p>	 <p data-bbox="903 536 1100 571">Ø7.8x30mm</p>	 <p data-bbox="1268 536 1445 571">M6x20mm</p>
79 pcs	79 pcs	54 pcs	8 pcs

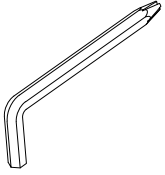
E	F	G	H
 <p data-bbox="219 1024 393 1059">M6x60mm</p>	 <p data-bbox="568 1024 745 1059">Ø4x50mm</p>	 <p data-bbox="915 1024 1120 1059">M6XØ23mm</p>	 <p data-bbox="1314 1024 1372 1059">M4</p>
4 pcs	10 pcs	6 pcs	1 pc

I			
 <p data-bbox="241 1512 373 1547">Ø21mm</p>			
32 pcs			

## Installation of Cams and Pins

Step 1-2: Align the plastic part with the mounting hole and press it in. If you can't press it in, loosen the screw counter clockwise or completely remove the screw from the plastic part and try again.  
Step 3-4: After pressing the plastic part into place, use a screwdriver to tighten the screw clockwise.

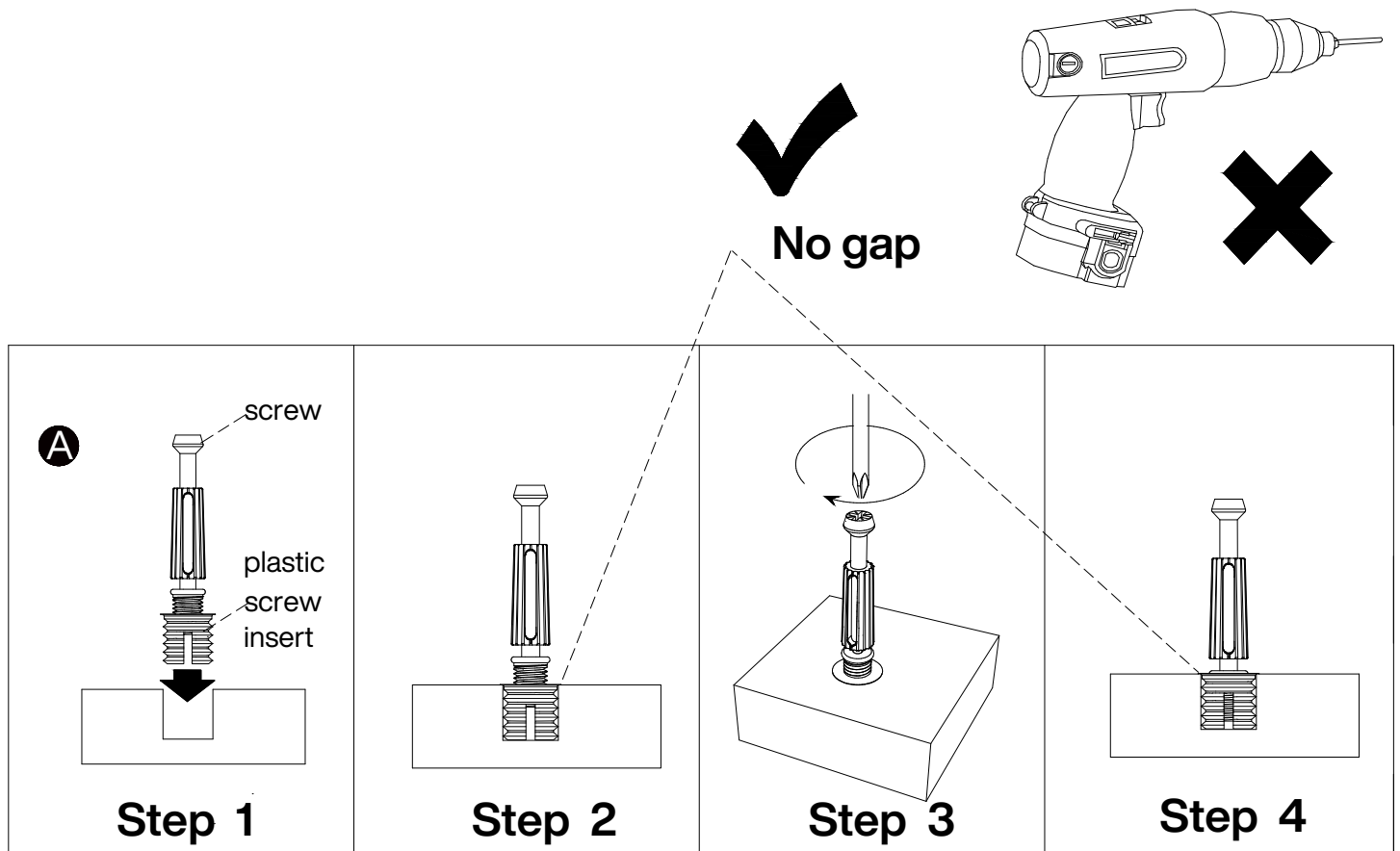

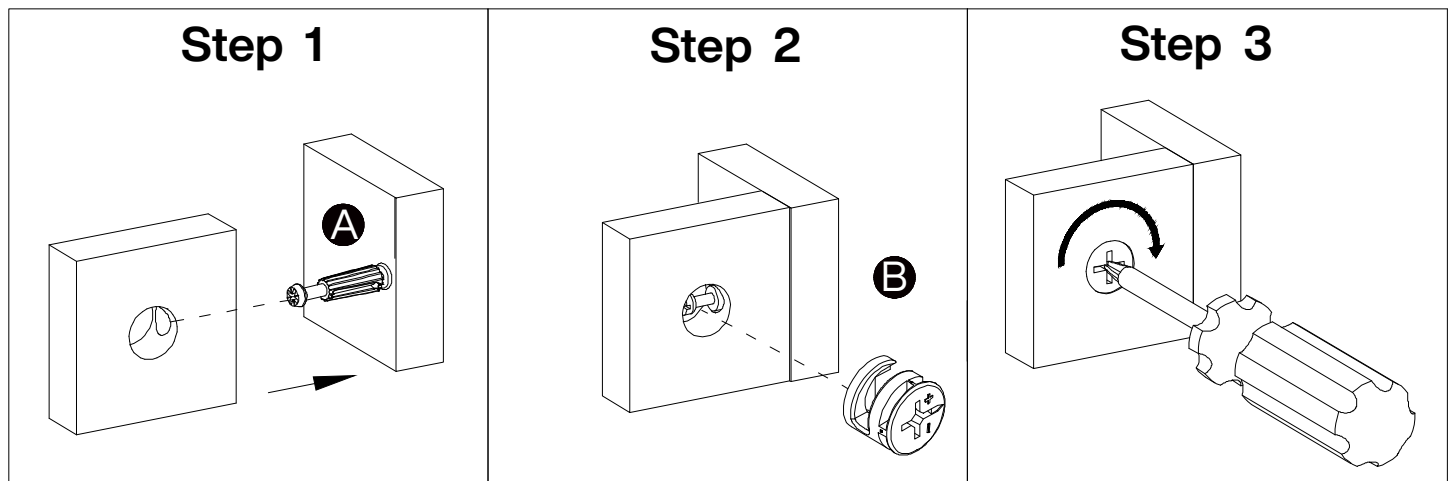

Screw the pin into the hole. Set the cams correctly by aligning the head of the cams with the lock pins. Lock the cam by turning the cam head with a screwdriver until it is tightened. Please do not use an electric screwdriver to assemble the unit.





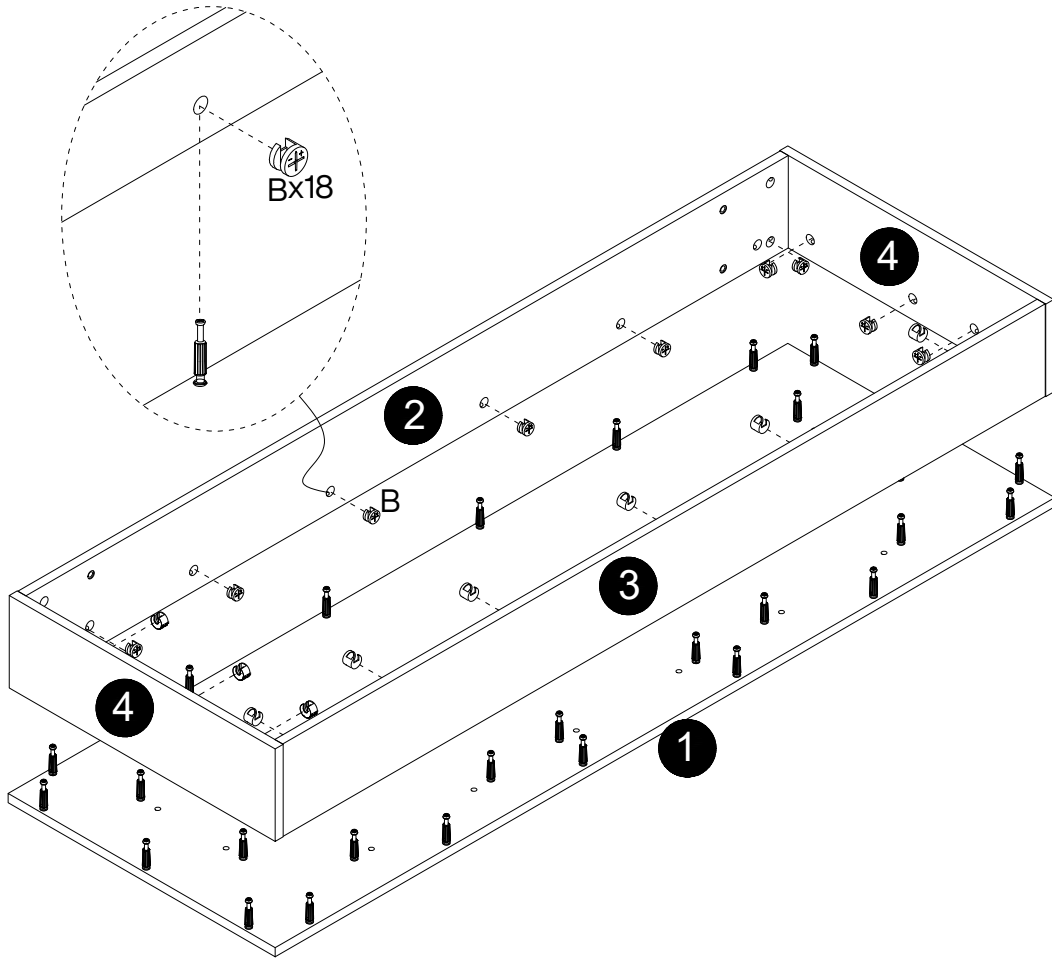

**3**

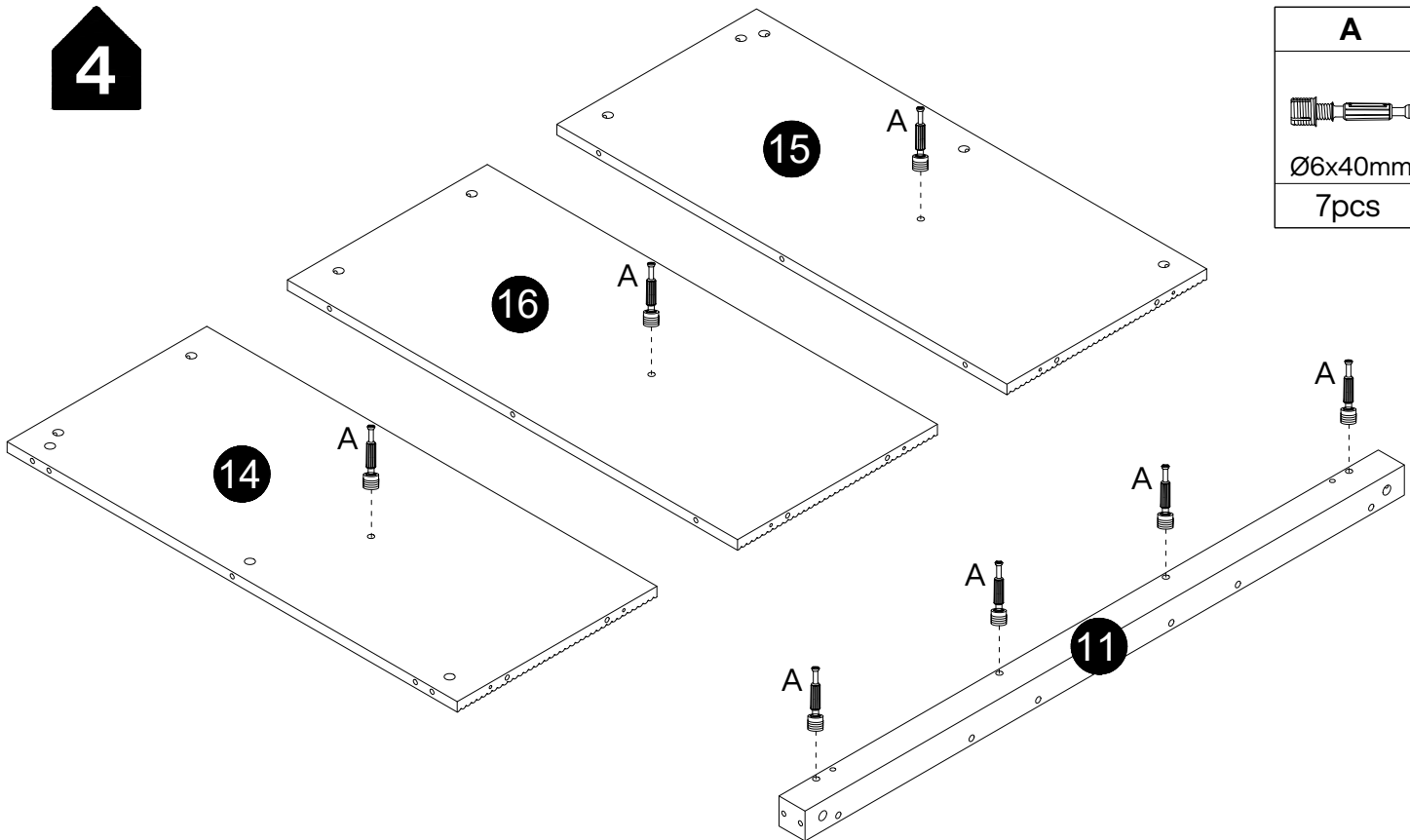

<b>B</b>

Ø15x12mm
18 pcs

**4**



<b>A</b>

Ø6x40mm
7 pcs

5

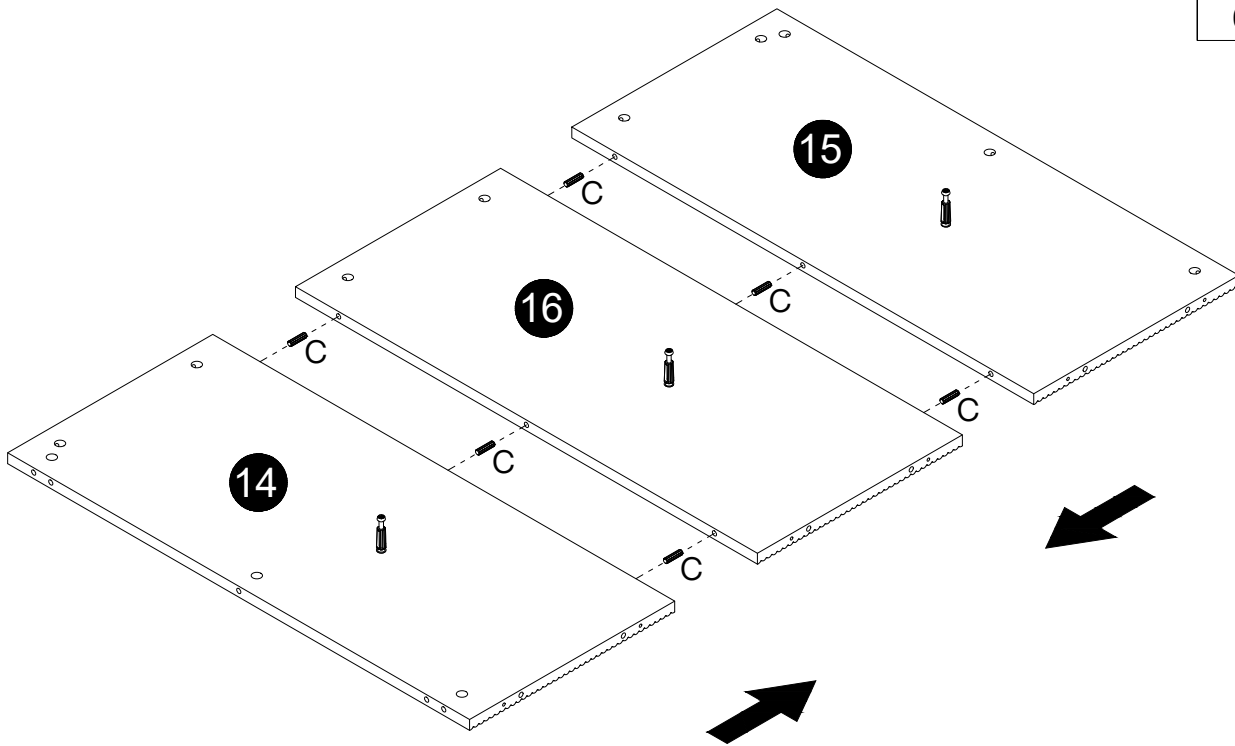
<b>C</b>

Ø7.8x30mm
6 pcs

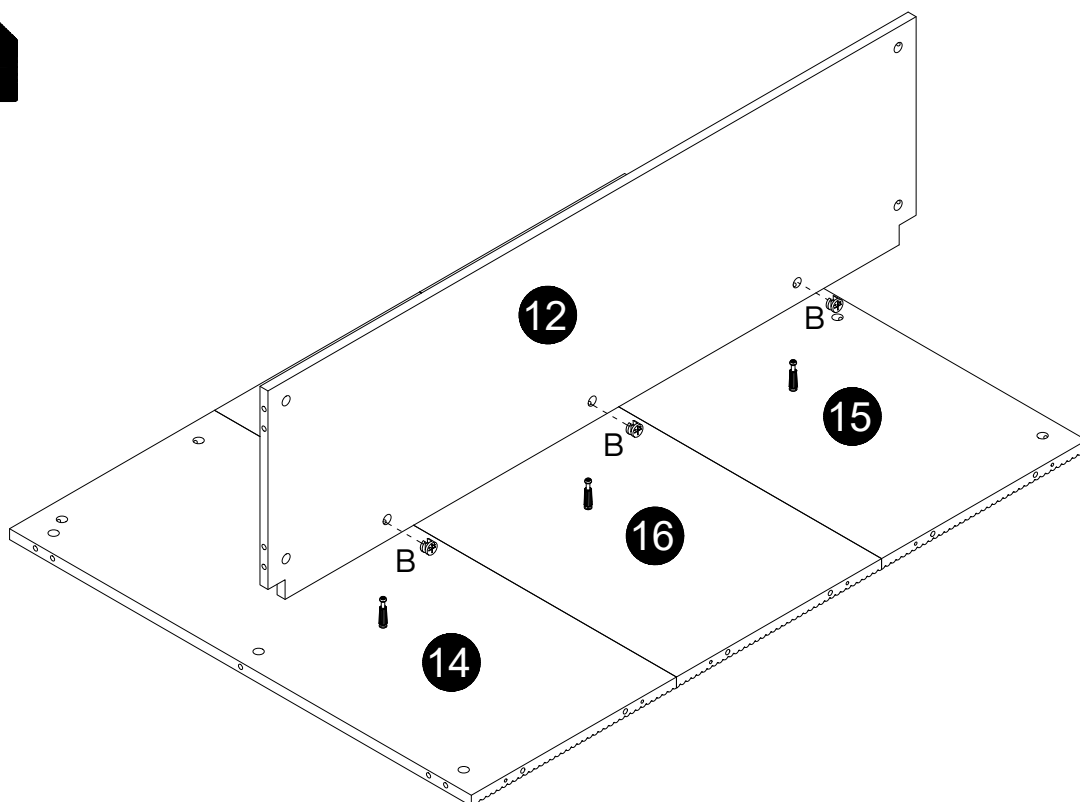

6

<b>B</b>

Ø15x12mm
3 pcs



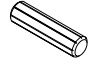

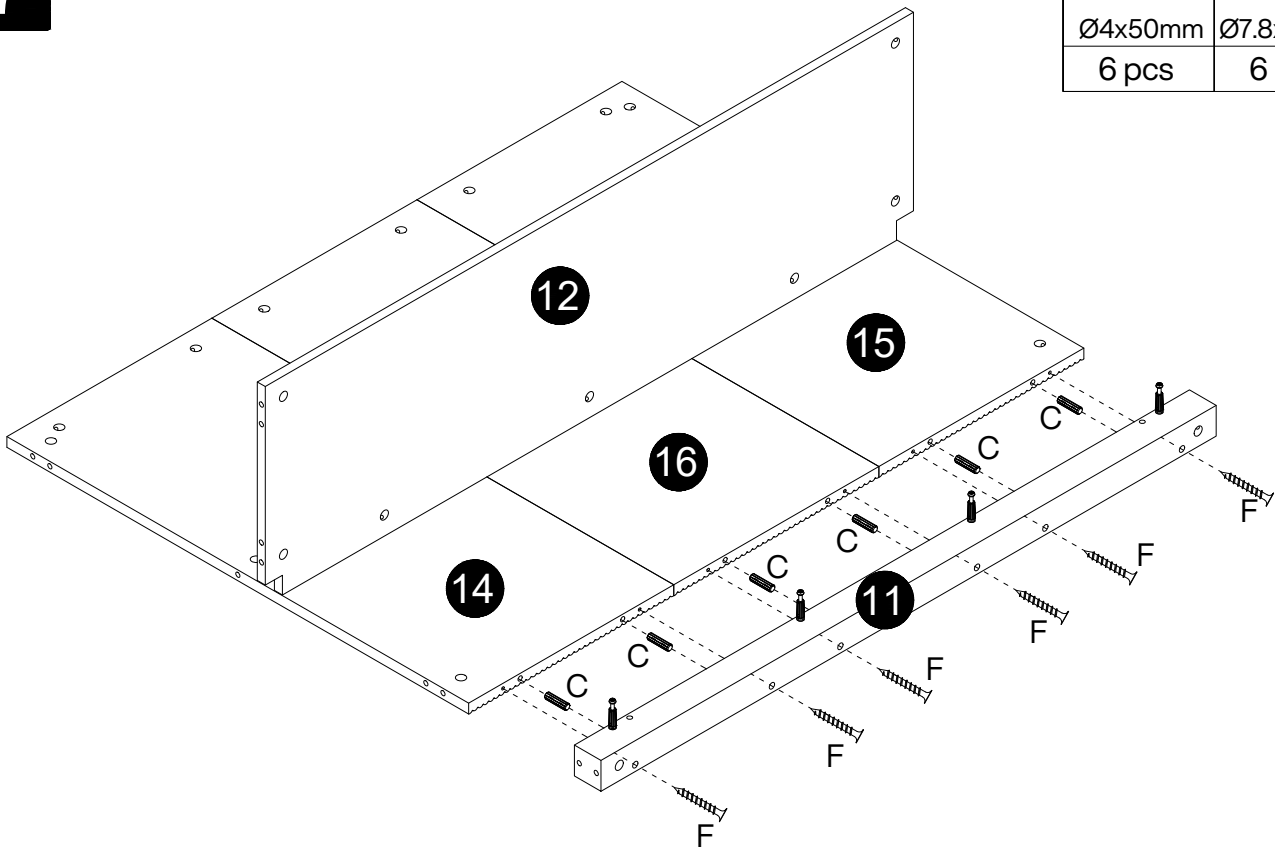
7

F	C
	
Ø4x50mm	Ø7.8x30mm
6 pcs	6 pcs

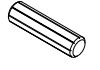

8

C	B
	
Ø7.8x30mm	Ø15x12mm
2 pcs	4 pcs

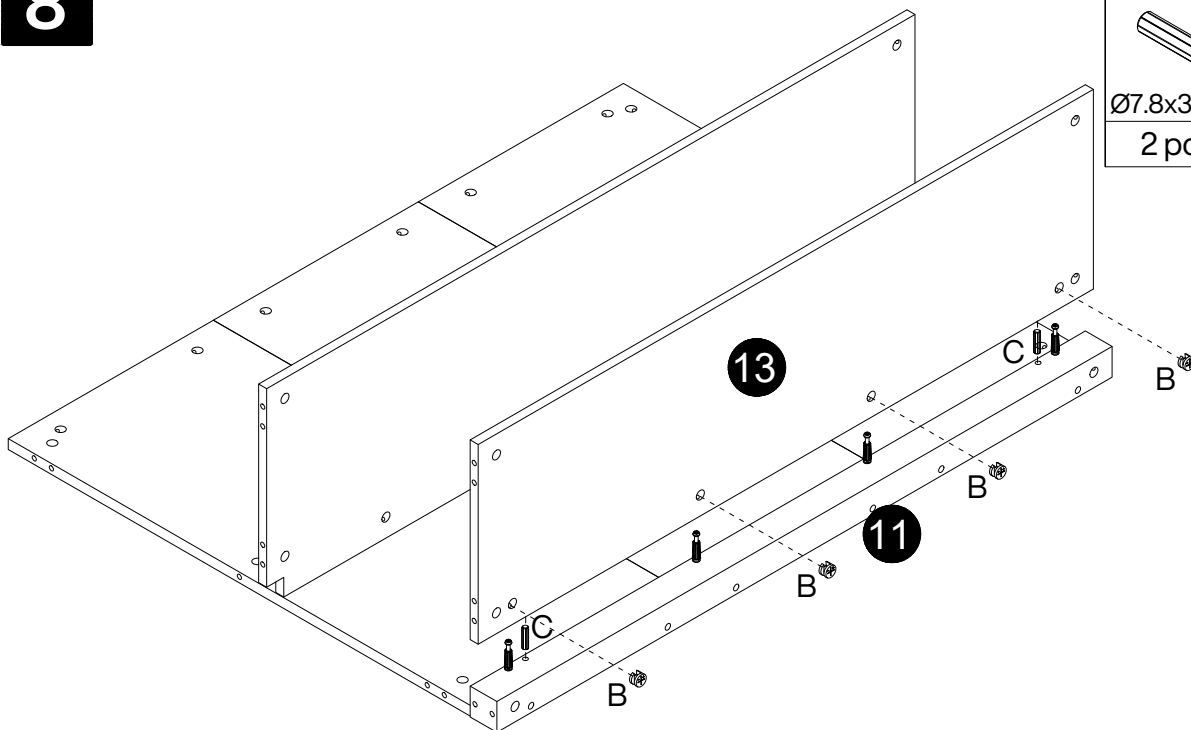

9

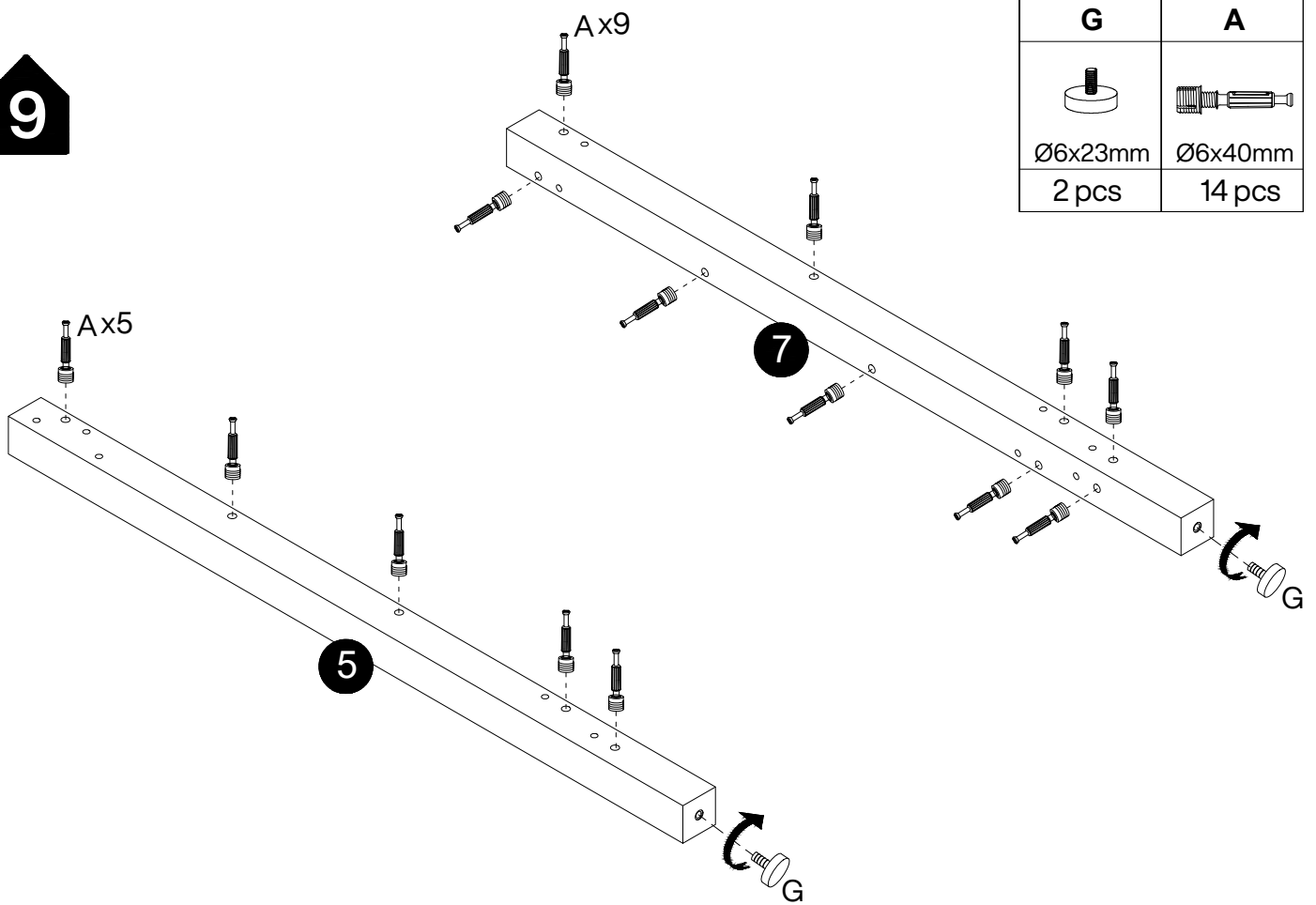

10

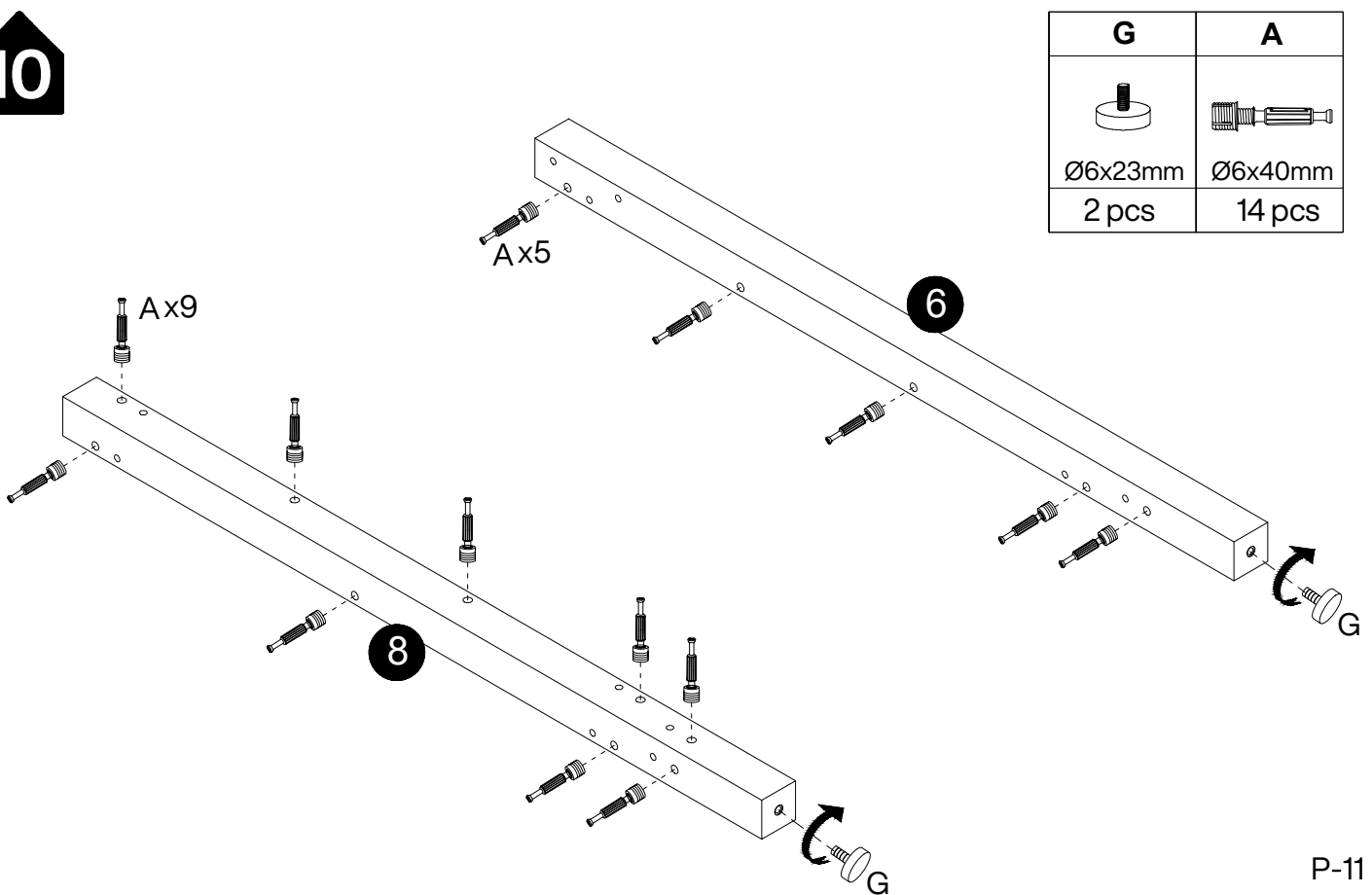

11

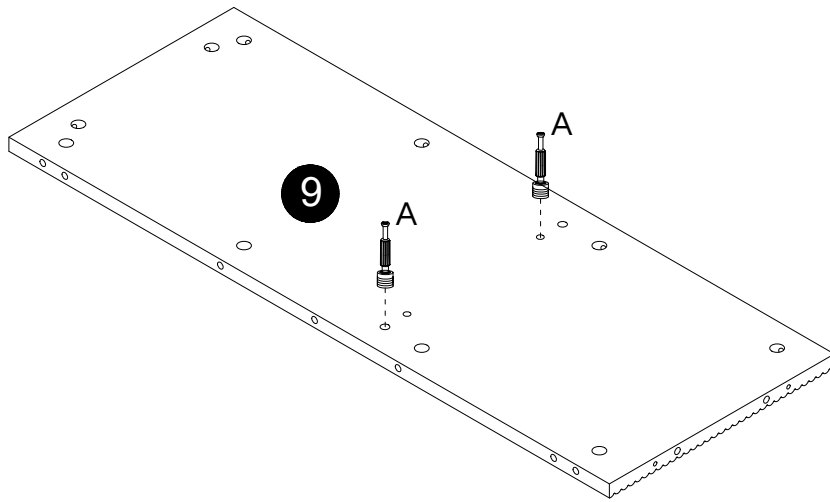

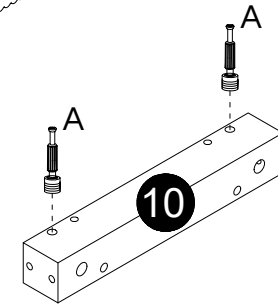

A

Ø6x40mm
8 pcs

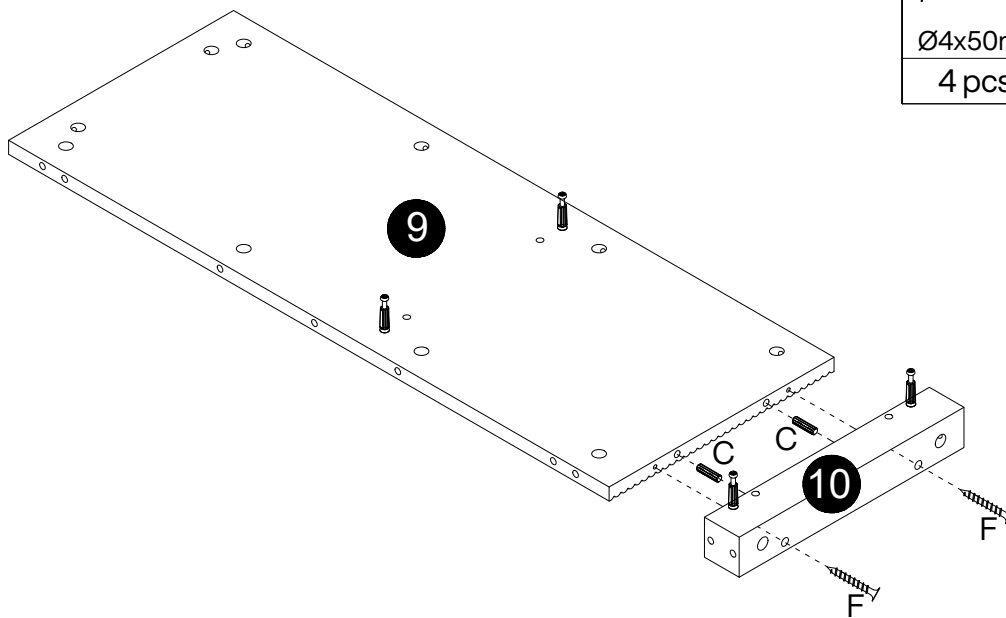

x2

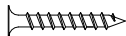
12





F	C
	
Ø4x50mm	Ø7.8x30mm
4 pcs	4 pcs

x2

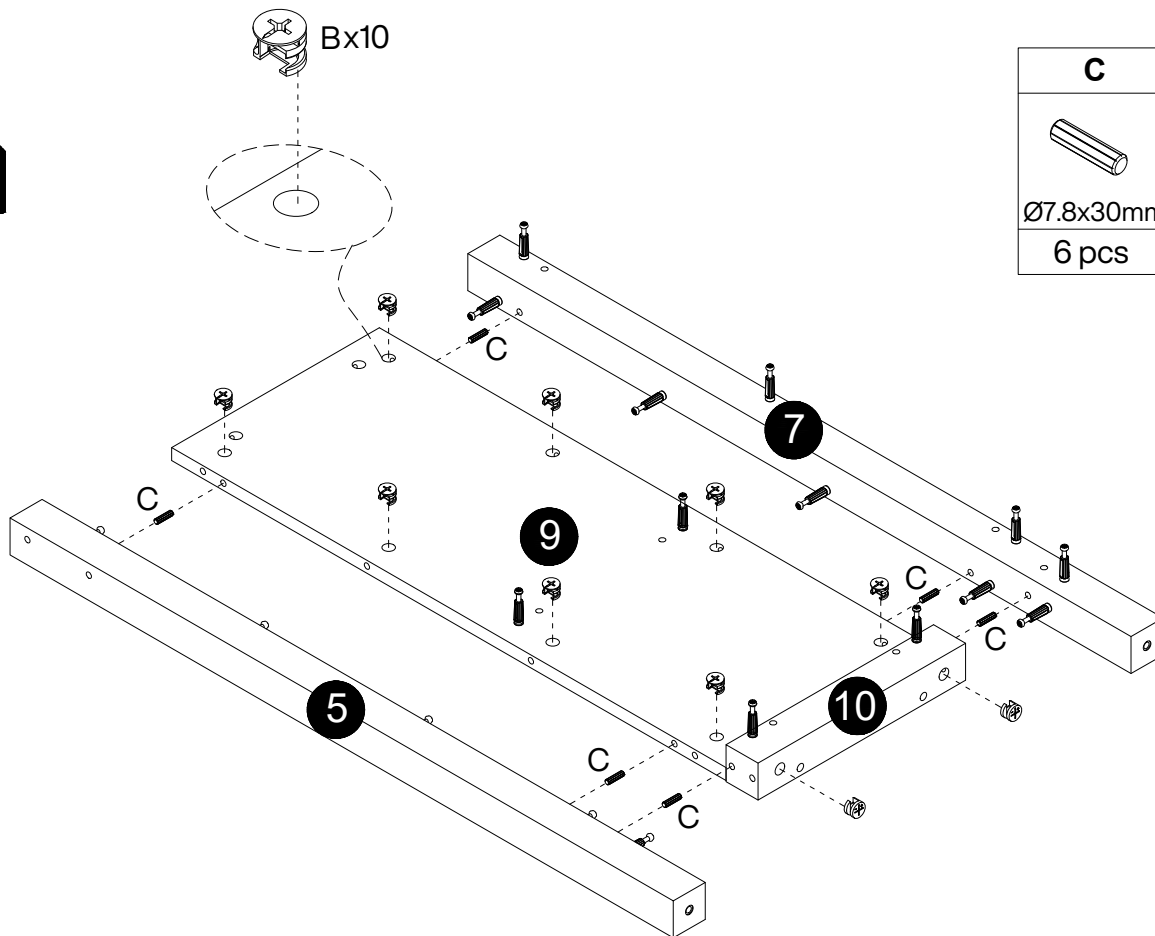

13



C	B
	
Ø7.8x30mm	Ø15x12mm
6 pcs	10 pcs

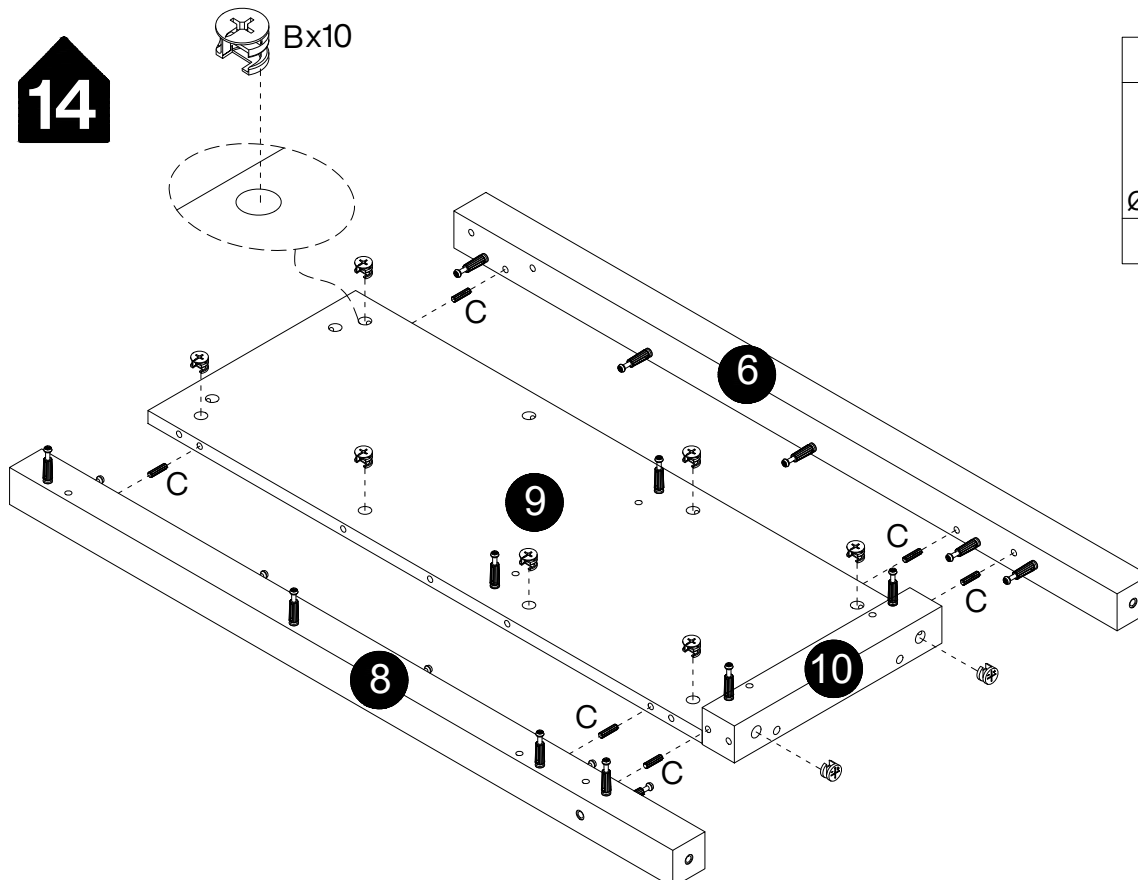

14



C	B
	
Ø7.8x30mm	Ø15x12mm
6 pcs	10 pcs

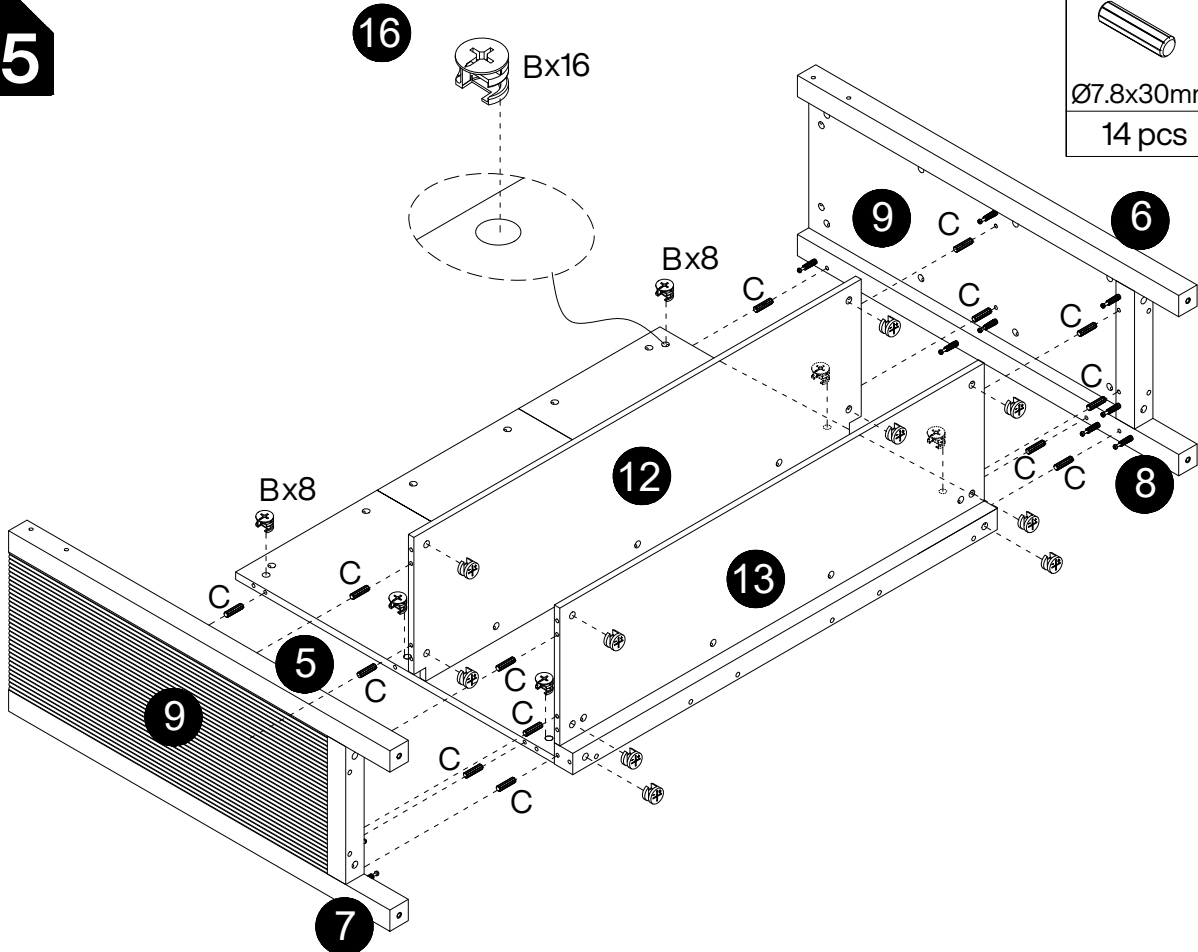

15



C	B
	
Ø7.8x30mm	Ø15x12mm
14 pcs	16 pcs

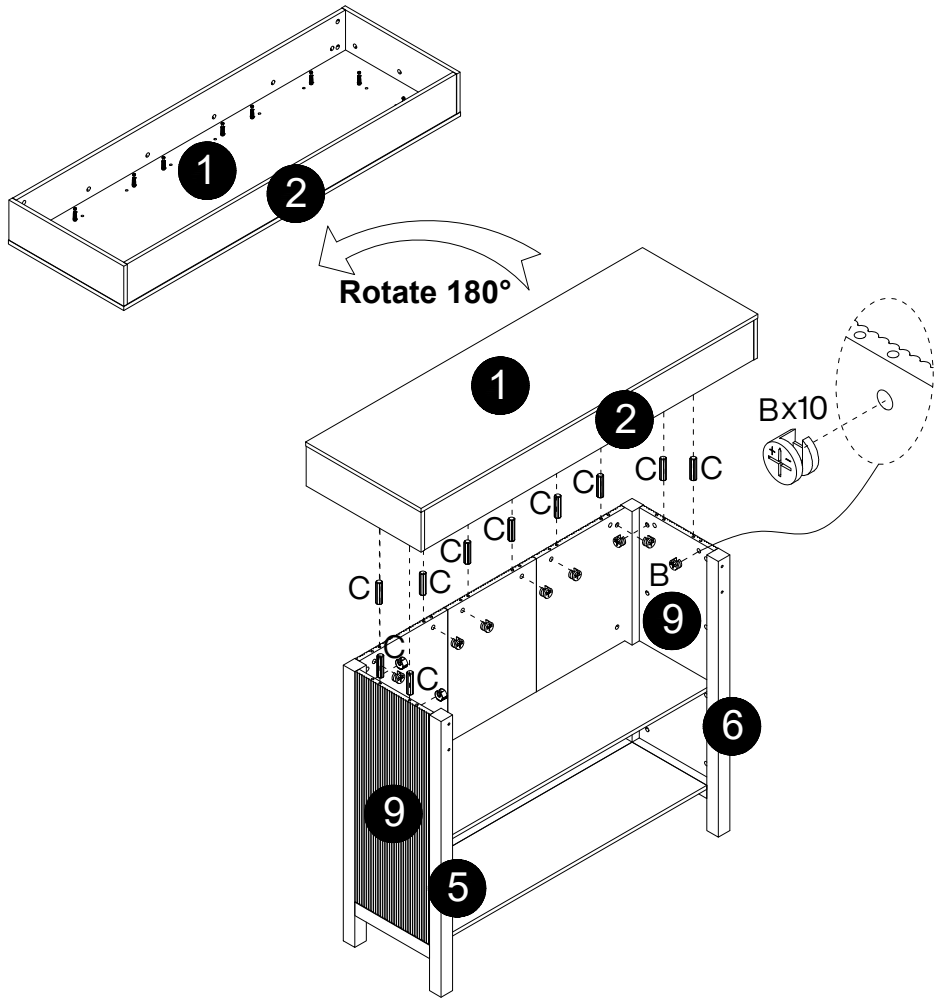

16

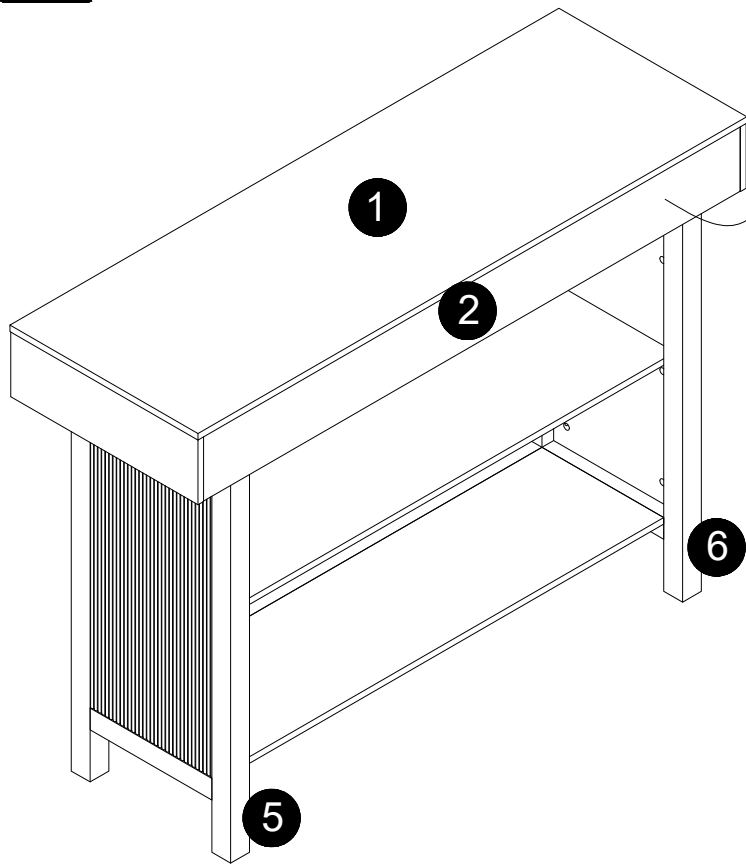

C	B
	
Ø7.8x30mm	Ø15x12mm
10 pcs	10 pcs

17



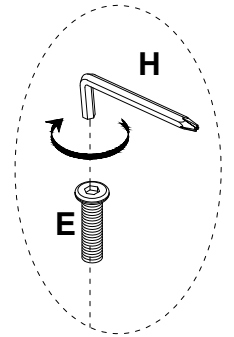
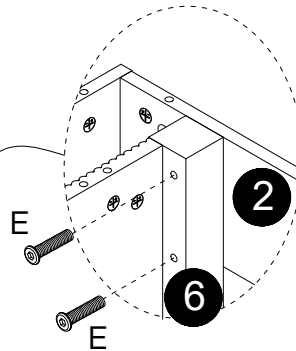

E	H
	
M6x60mm	M4
4 pcs	1 pc

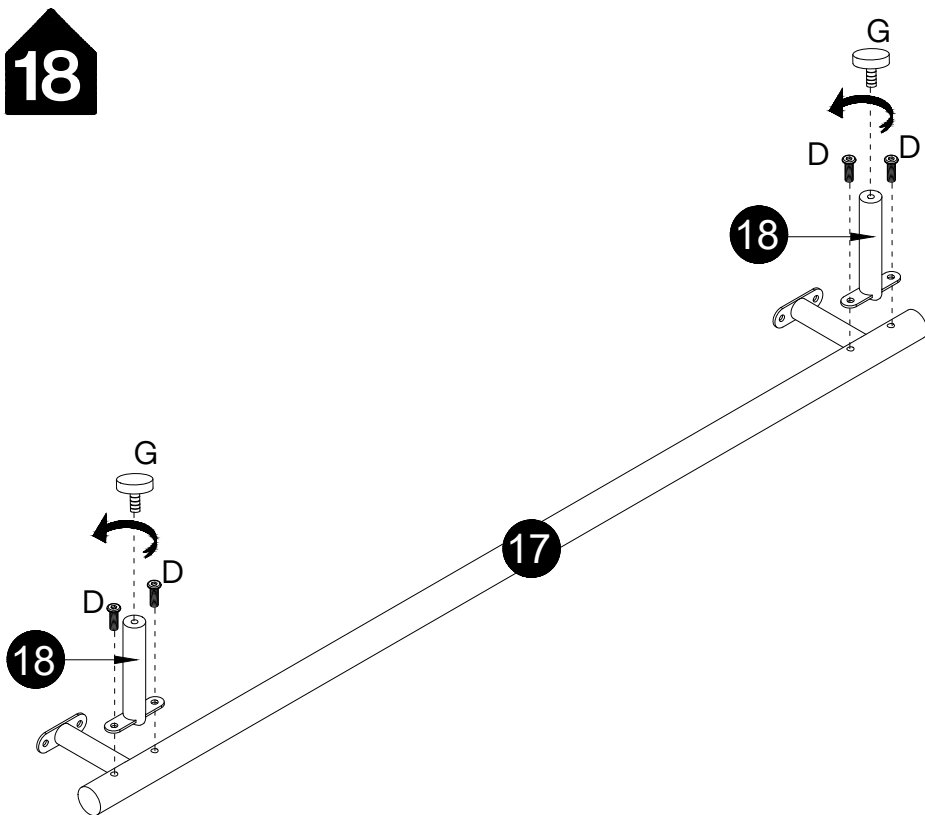

18



G	D	H
		
Ø6x23mm	M6x20mm	M4
2 pcs	4 pcs	1 pc

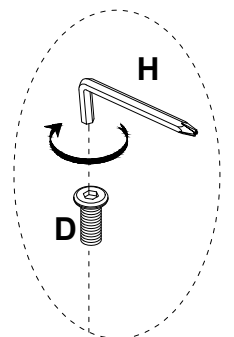
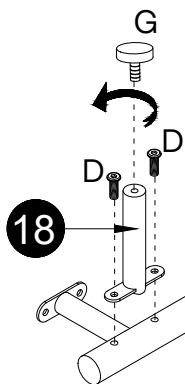
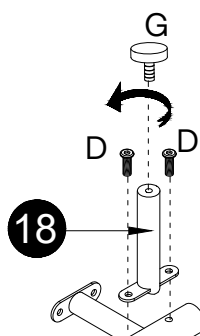

19

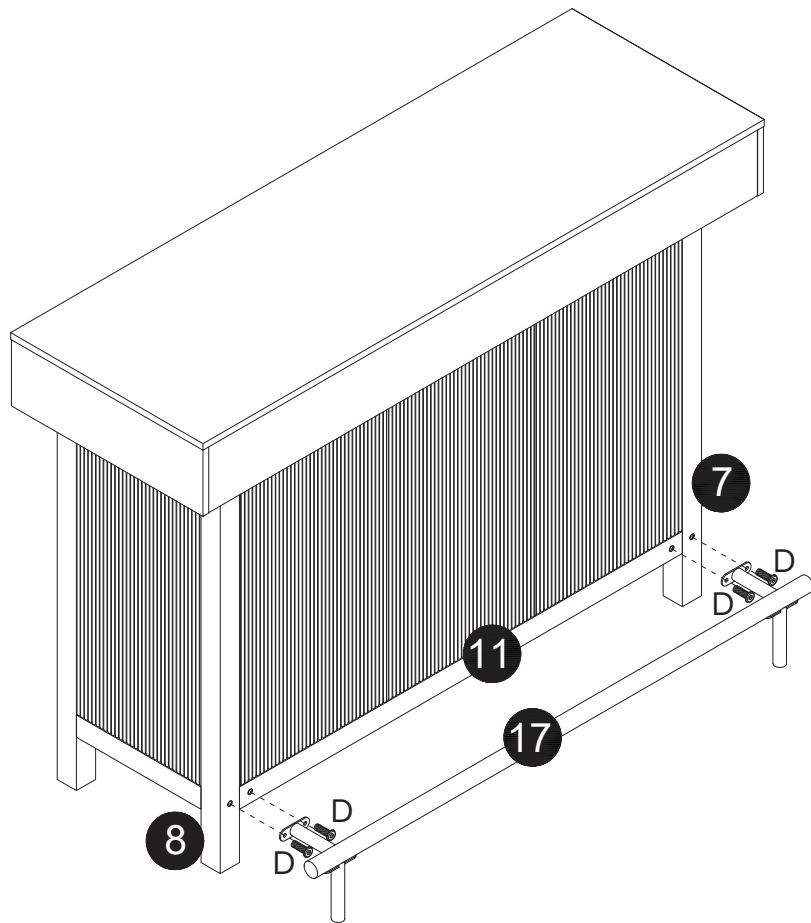

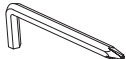
D	H
	
M6x20mm	M4
4 pcs	1 pc

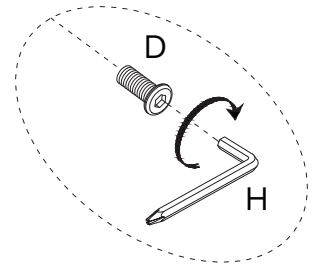

20

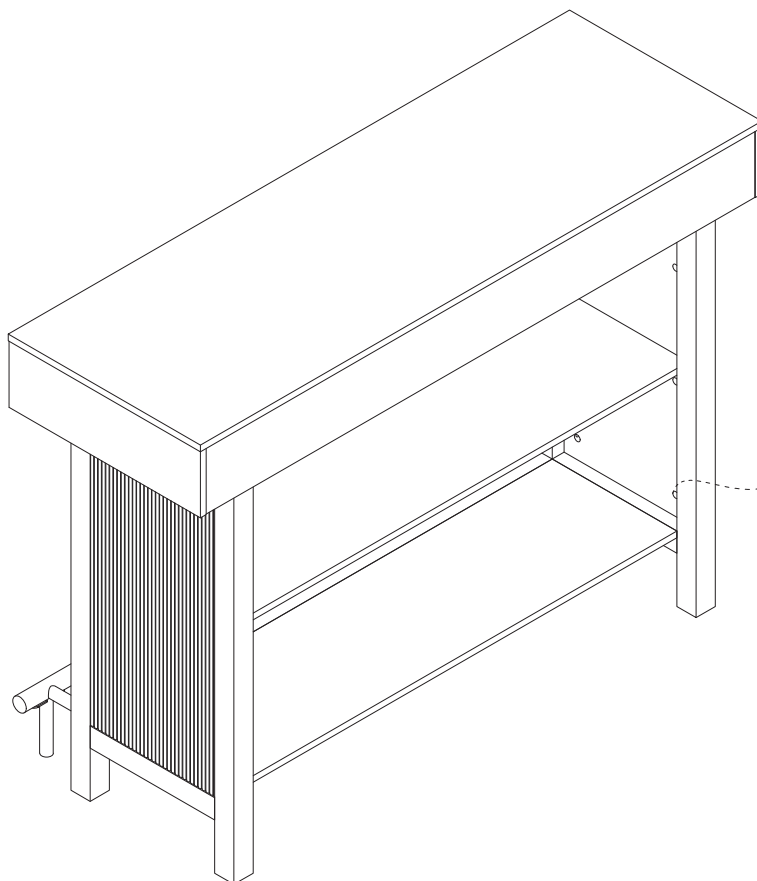

I

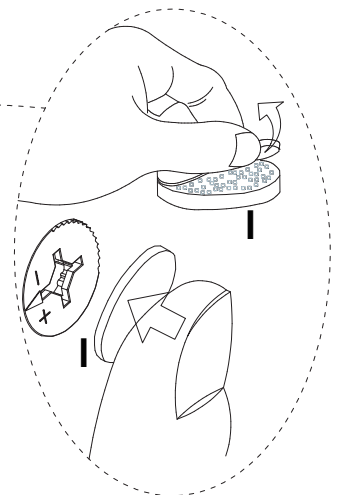
Ø21mm
32 pcs



**Thank you for your support!**

