

**Per Shelf**  
**Par étagère**  
**Por estante**



**Read through ALL instructions before commencing installation.**

If you have any questions about this product or issues with installation, contact the customer services helpline before returning this product to the store.



**Lisez TOUTES les instructions avant de débuter l'installation.**

Si vous avez des questions sur ce produit ou des problèmes d'installation, contactez l'assistance client avant de ramener le produit en magasin.



**Lea TODAS las instrucciones antes de comenzar la instalación.**

Si tiene alguna pregunta sobre el producto o problemas con la instalación, llame a la línea de servicio al consumidor antes de devolverlo.

Index  
Index  
Indice

**1** Measure the TV fixing holes Width and Height  
*Mesurer la profondeur et la taille des trous de fixation*  
Mida los orificios de su TV, lo ancho y lo alto

**2** Fitting the TV Brackets  
*Montage des supports TV*  
Fije los Brazos del Soportes a su TV

**3** Connecting the Wall Brackets  
*Connexion des fixations murales*  
Conexión de los soportes de pared

**4** Assembling the Shelf and TV Support  
*Assemblage de l'étagère et du support pour TV*  
Armado del estante y soporte de TV

**5** Fitting the Wall Bracket  
*Installer l'applique murale*  
Fijando la Placa a la Pared

**6** Fitting the Shelf Support  
*Fixer le support de l'étagère*  
Adaptación del soporte del estante

**7** Fitting the TV Support Bracket  
*Montage de la fixation du support de la TV*  
Colocación de la ménsula del soporte de TV

**8** Fitting the End Caps and Cable Management  
*Montage des capuchons d'extrémité et ordonnancement des cordons*  
Colocación de terminales y organizador de cables

**9** Fitting the TV Bracket  
*Montage de la fixation de la TV*  
Fije los Brazos del Soporte a su TV

**10** Fitting the Shelf  
*Fixer la étagère*  
Ajuste de la plataforma

**11** Attach the TV  
*Fixer la TV*  
Coloque la TV

Retain all packaging in case the bracket needs to be returned.

Contents may vary from photography/ Illustrations.

You will not need all these parts, so expect there to be some left over depending upon the specification of your TV.

This product is intended for indoor use only. Use of this product outdoors could lead to failure and personal injury.

It is the responsibility of the installer to ensure that the mounting wall is of a suitable standard and void of any services (eg gas, electricity, water etc).

AVF accept no responsibility for any damage or loss caused by installing this product in a sub standard wall.

*Conserver les emballages si l'applique a besoin d'être ramenée.*

*Les contenus peuvent varier de la photographie/illustrations.*

*Vous n'aurez pas besoin de toutes ces pièces, attendez-vous donc à ce qu'il reste des pièces selon les caractéristiques de votre téléviseur.*

*Ce produit est à utiliser à l'intérieur uniquement. Utiliser ce produit à l'extérieur causera des défaillances et de possibles accidents.*

*Il est de la responsabilité de l'installateur de s'assurer que les murs soient aux critères requis et vides de tout câblage (ex : gaz, électricité, eau etc....)*

*AVF n'acceptera aucune responsabilité pour tout dommage ou perte causée par l'installation du produit dans un mur en deçà de ces critères.*

Conserve todos los envasados en caso de que el soporte tenga que ser devuelto.

El contenido puede variar de la fotografía / ilustración.

No necesitará todas estas partes, espere que sobren algunas según las especificaciones de su TV.

Este producto está diseñado para el uso en el interior solamente. El uso de este producto en el exterior podría llevar al fracaso y lesiones personales.

Es la responsabilidad del instalador de asegurarse de que la pared de montaje es de un nivel adecuado y carece de todo los servicios (gas, electricidad, agua, etc.).

AVF no acepta ninguna responsabilidad por cualquier daño o pérdida causada por la instalación de este producto en una pared inadecuada.

Tools Recommended  
*Outils recommandés*  
Herramientas recomendadas

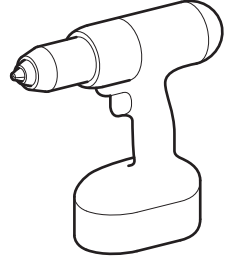
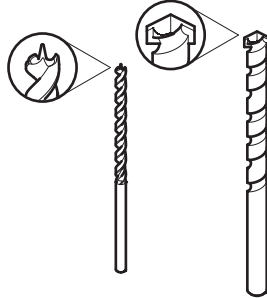
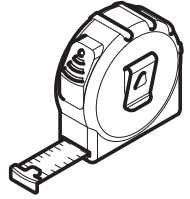
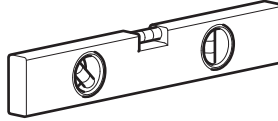
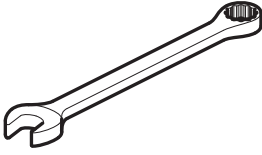
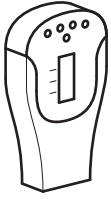

Boxed Parts  
*Pièces emballées*  
Piezas en la Caja

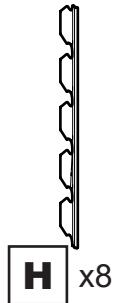
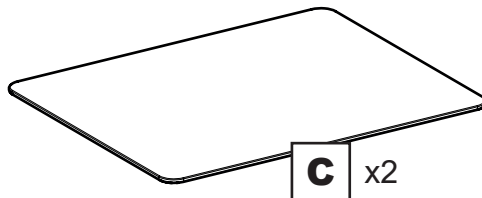
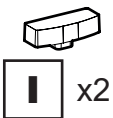
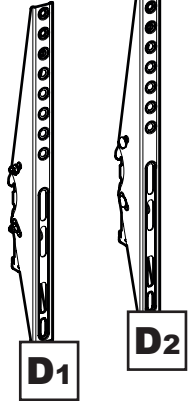
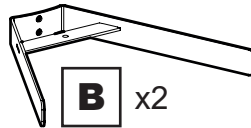
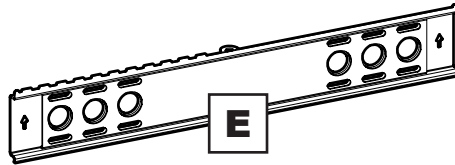
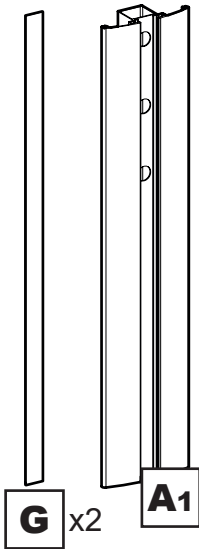

Boxed Parts  
Pièces empaquetées  
Piezas en la Caja

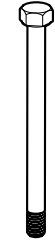

**J**



M8

**K**



M8

**L**



**M** x2

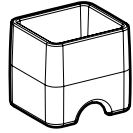

**N**

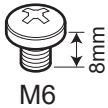

M6

**O** x2

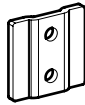

**P** x4

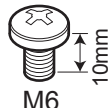

M6

**Q** x8

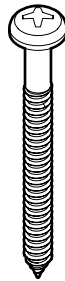

**U** x5

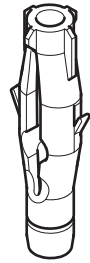

**V** x5

TV Screws, Reducers and Spacers  
Vis TV, réducteurs et séparateurs  
Tornillos, Reductores y Espaciadores para TV



**R** x4



**S1** x12



**S2** x4

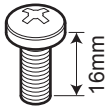

M6

**T1** x4

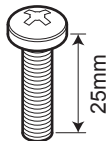

M6

**T2** x4

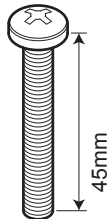

M6

**T3** x4

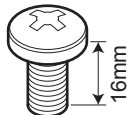

M8

**T4** x4

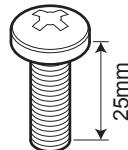

M8

**T5** x4

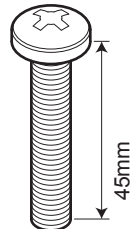

M8

**T6** x4

**1**

**Measure the TV fixing holes Width and Height**  
**Mesurer la profondeur et la taille des trous de fixation**  
**Mida los orificios de su TV, lo ancho y lo alto**

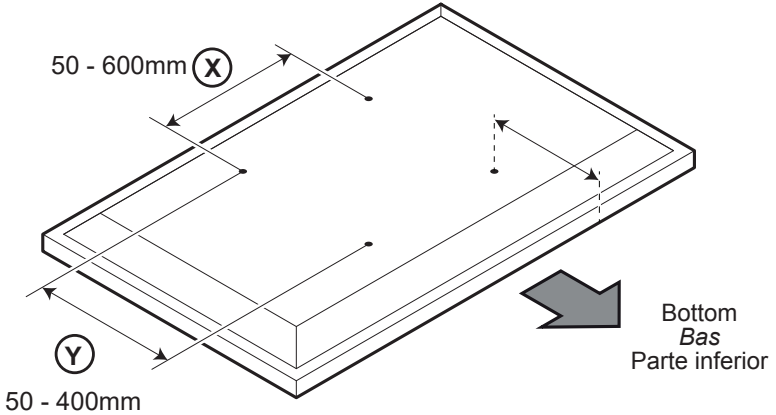

If width **(X)** is greater than 600mm or height **(Y)** greater than 400mm, **OR** if the distance from the bottom fixing holes to the bottom of your TV is more than 240mm, **STOP** installation now and contact the customer helpline.

*Si la largeur **(X)** est plus large que 600 mm et la hauteur **(Y)** plus grande que 400mm, **OU** si les mesures entre les trous de fixation de la partie basse et la base de votre téléviseur dépasse les 240mm **ARRÊTEZ** l'installation immédiatement et contactez l'assistance client.*

Si la anchura **(X)** es mayor que 600mm o la altura de **(Y)** es mayor que 400mm **O** si la distancia desde los orificios inferiores de fijación a la parte inferior del televisor es superior a 240mm **DETENGA** la instalación inmediatamente y póngase en contacto con la línea de ayuda al cliente.

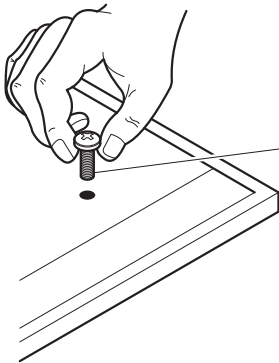

**M6 = T<sub>1</sub>/T<sub>2</sub>/T<sub>3</sub>**

**M8 = T<sub>4</sub>/T<sub>5</sub>/T<sub>6</sub>**

You are provided with 2 diameters of TV fixing screws, **M6** and **M8**. Determine the screw diameter that fits and remember for step 2.

*2 diamètres de vis TV vous sont fournis: **M6** y **M8**. Déterminez le diamètre de la vis qui convient et mémorisez- le pour l'étape 2.*

Se le proporciona con 2 diámetros de tornillos de fijación para su TV: **M6** y **M8**. Determine el diámetro del tornillo que le quede a su TV y recuérdelo para el paso 2.

**2**

Fitting the TV Brackets  
*Montage des supports TV*  
 Fije los Brazos del Soportes a su TV

No Spacers  
*Pas de séparateur*  
 Sin espaciadores

For TVs with flat / unobstructed back  
*Pour des téléviseurs aux dos plats et non obstrués*  
 Para TVs con la parte posterior plana / sin obstáculos

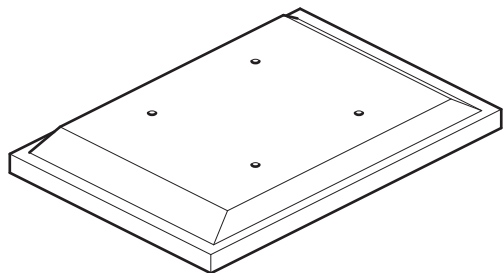

Spacers  
*Séparateurs*  
 Espaciadores

**S1/S2**

For TVs with irregular / obstructed back  
*Pour des téléviseurs aux dos irréguliers et non obstrués*  
 Para TVs con la parte posterior irregular / con obstáculos

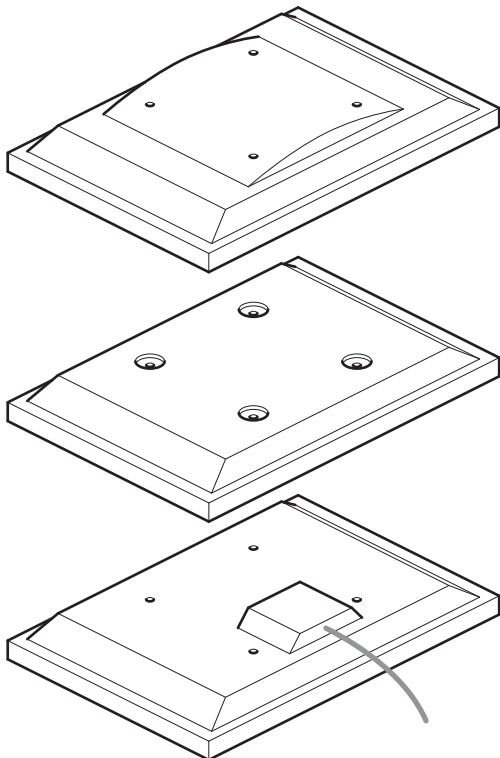

WARNING / AVERTISSEMENT / ADVERTENCIA

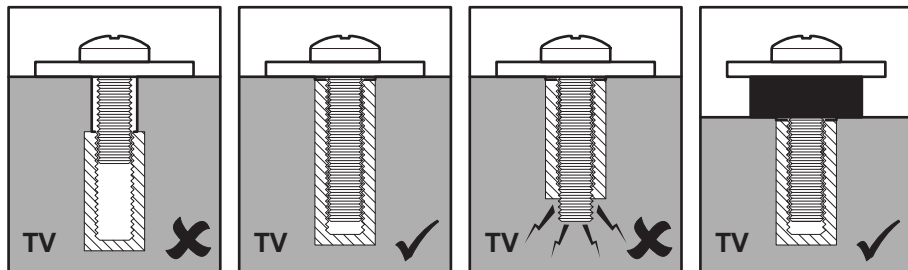

After completing step 2 you will have fittings left over, please keep for future reference.  
*Après avoir complété l'étape 2 il vous restera des pièces d'assemblage, conservez-les.*  
 Después de completar el paso 2 usted tendrá conexiones sobrantes, por favor guarde para futura referencia.

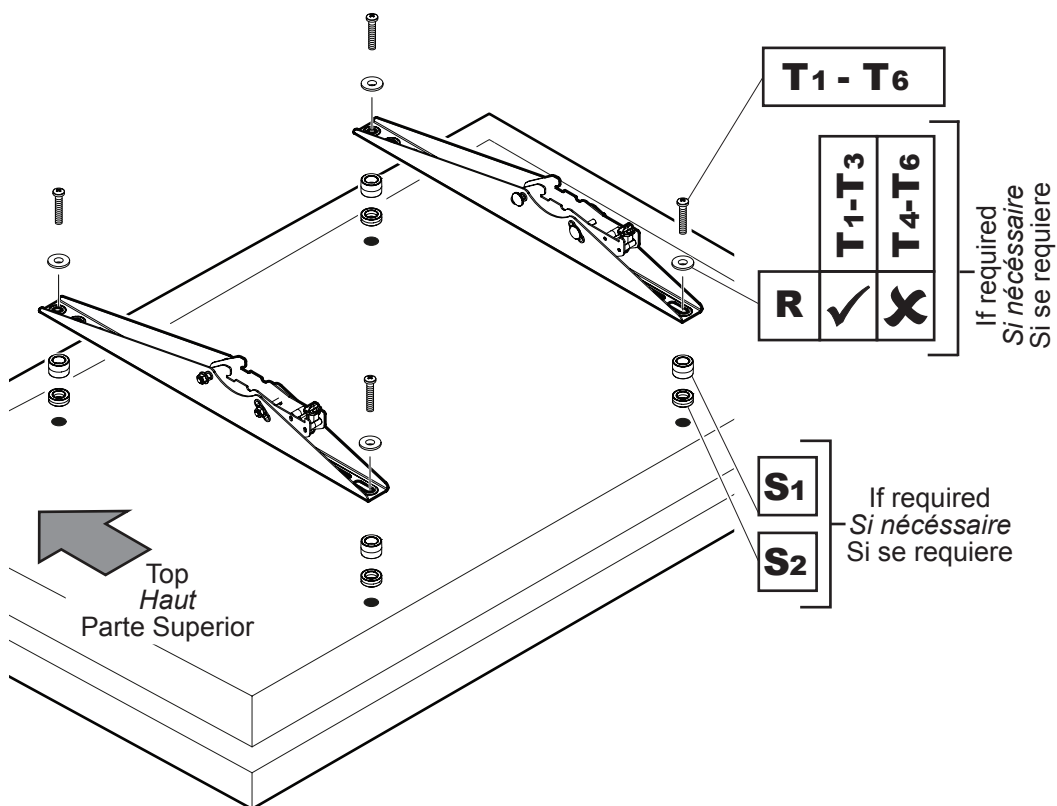

Attach the bracket to the back of your TV using suitable screw, reducer and spacer combinations.  
*Attachez l'applique au dos de votre téléviseur en utilisant une combinaison de vis, de séparateurs et de joints adaptés.*

Coloque los soportes a la parte posterior de su TV usando la combinación adecuada de tornillo, reductor y espaciador.

**3**

Connecting the Wall Brackets  
 Connexion des fixations murales  
 Conexión de los soportes de pared

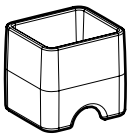
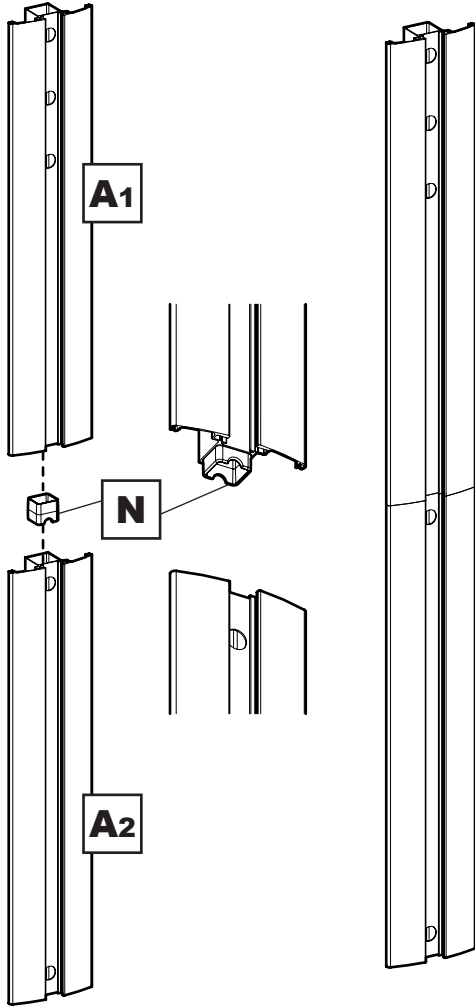
**N****4**

Assembling the Shelf and TV Support  
 Assemblage de l'étagère et du support pour TV  
 Armado del estante y soporte de TV

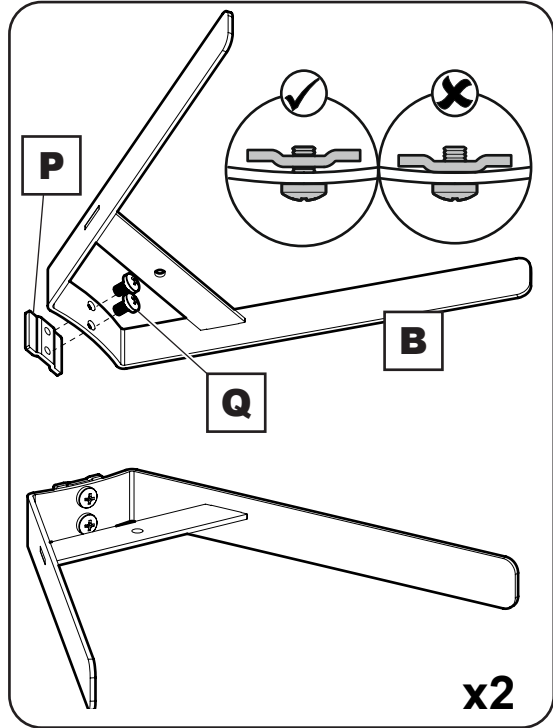
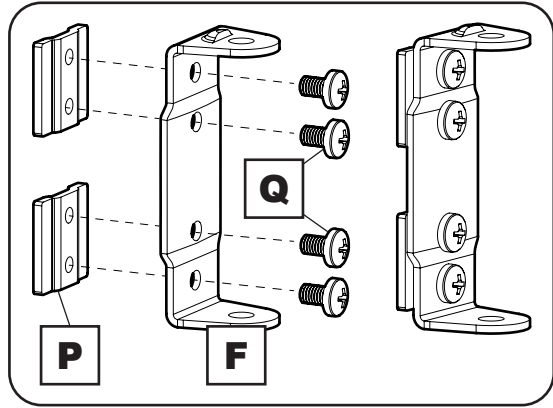
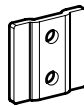
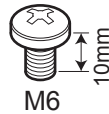
**x2****P** x4**Q** x8

**5**

**Fitting the Wall Bracket**  
*Installer l'applique murale*  
**Fijando la Placa a la Pared**

**Solid Wall**  
**Mur solide**  
**Pared s3dida**

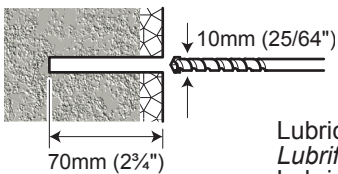
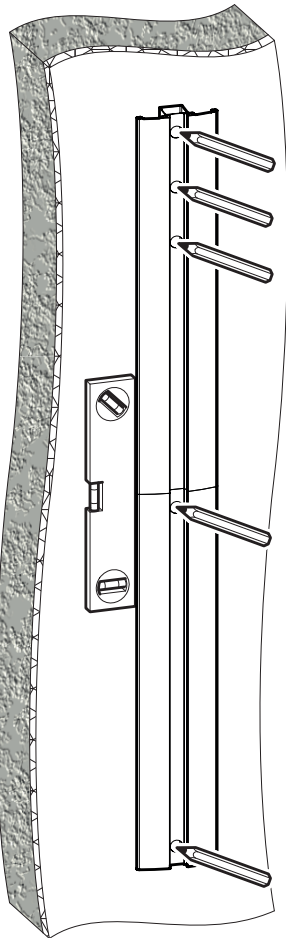

**Remove Dust from Hole**  
*Retirez la poussière du trou*  
**Elimine el polvo del agujero**



**Lubricate screw thread with soap**  
*Lubrifiez le pas de vis avec du savon*  
**Lubrique la rosca del tornillo con jab3n**



**DO NOT overtighten screws.**  
**Tighten screws by hand only**  
*Ne serrez pas trop les vis.*  
*Visser 3 la main seulement*  
**NO sobre apriete los tornillos.**  
**Apriete los tornillos s3lo a mano**

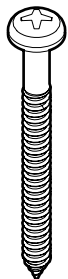
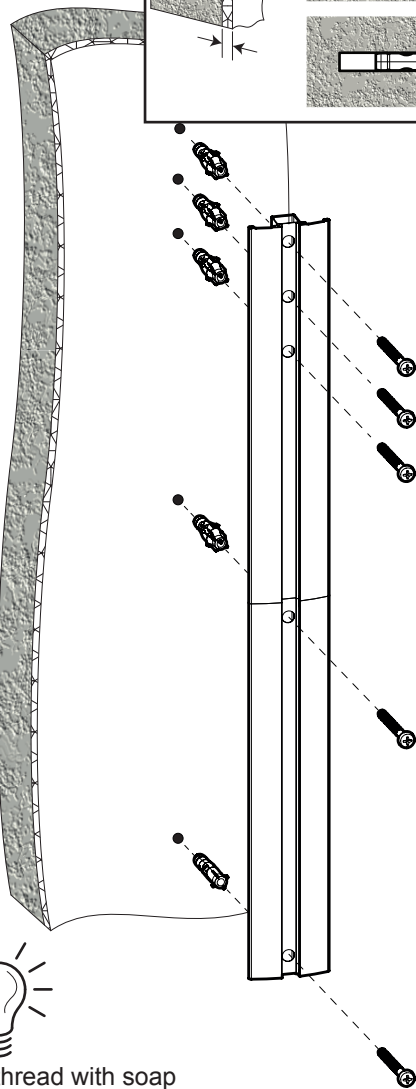
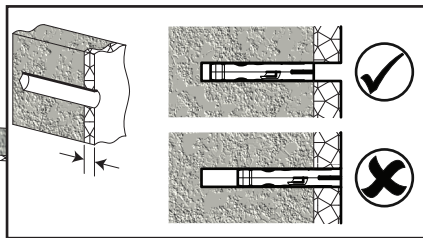

**U** x5

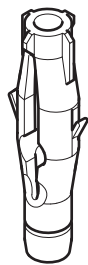

**V** x5

# 5

## Fitting the Wall Bracket *Installer l'applique murale* Fijando la Placa a la Pared

Wood Stud  
*Latte de bois*  
 Viga de madera

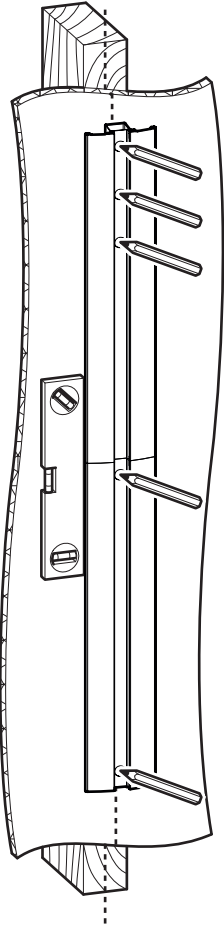

Ensure bracket is in the centre of the wood stud  
*Assurez-vous que l'applique est au centre de la latte de bois*  
 Asegúrese de que el soporte está en el centro de la viga de madera

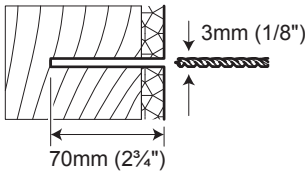
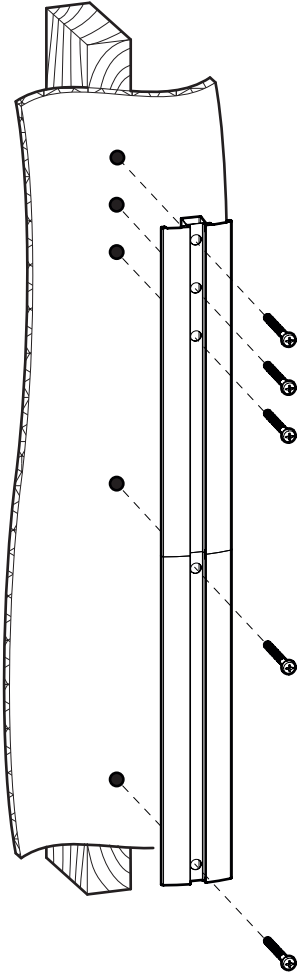
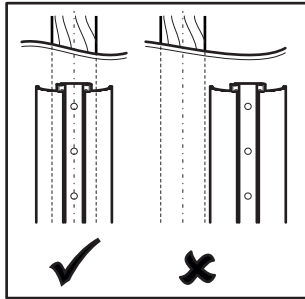

Lubricate screw thread with soap  
*Lubrifiez le pas de vis avec du savon*  
 Lubrique la rosca del tornillo con jabón



DO NOT overtighten screws.  
 Tighten screws by hand only  
*Ne serrez pas trop les vis.*  
*Visser à la main seulement*  
 NO sobre apriete los tornillos.  
 Apriete los tornillos sólo a mano

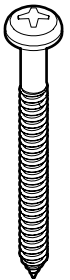

**U** x5

**6**

**Fitting the Shelf Support**  
*Fixer le support de l'étagère*  
**Adaptación del soporte del estante**

This way up  
*De cette façon jusqu'à*  
Por aquí hacia arriba

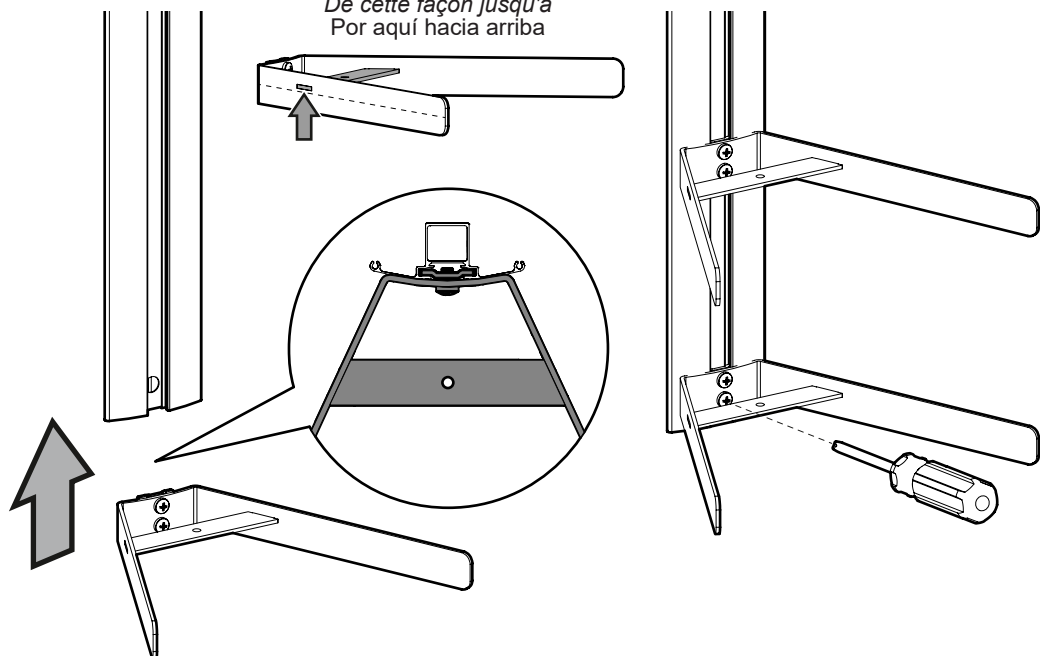
**7**

**Fitting the TV Support Bracket**  
*Montage de la fixation du support de la TV*  
**Colocación de la ménsula del soporte de TV**

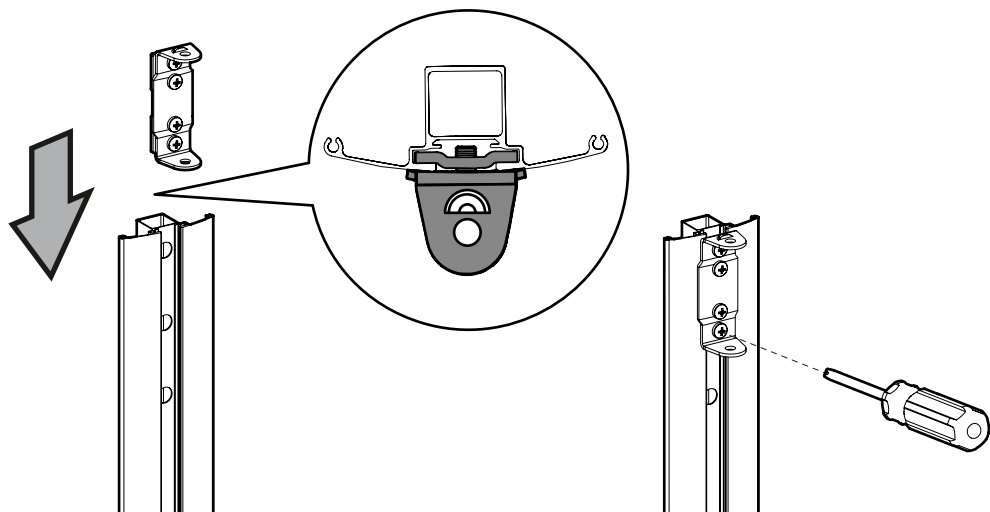



**9****Fitting the TV Bracket**  
**Montage de la fixation de la TV**  
**Fije los Brazos del Soporte a su TV**

Before tightening make sure the bolt is held in the position shown.  
*Avant de serrer, assurez-vous que le boulon est maintenu dans la position indiquée.*  
Antes de apretar, asegúrese de que el tornillo está sujeto en la posición mostrada.

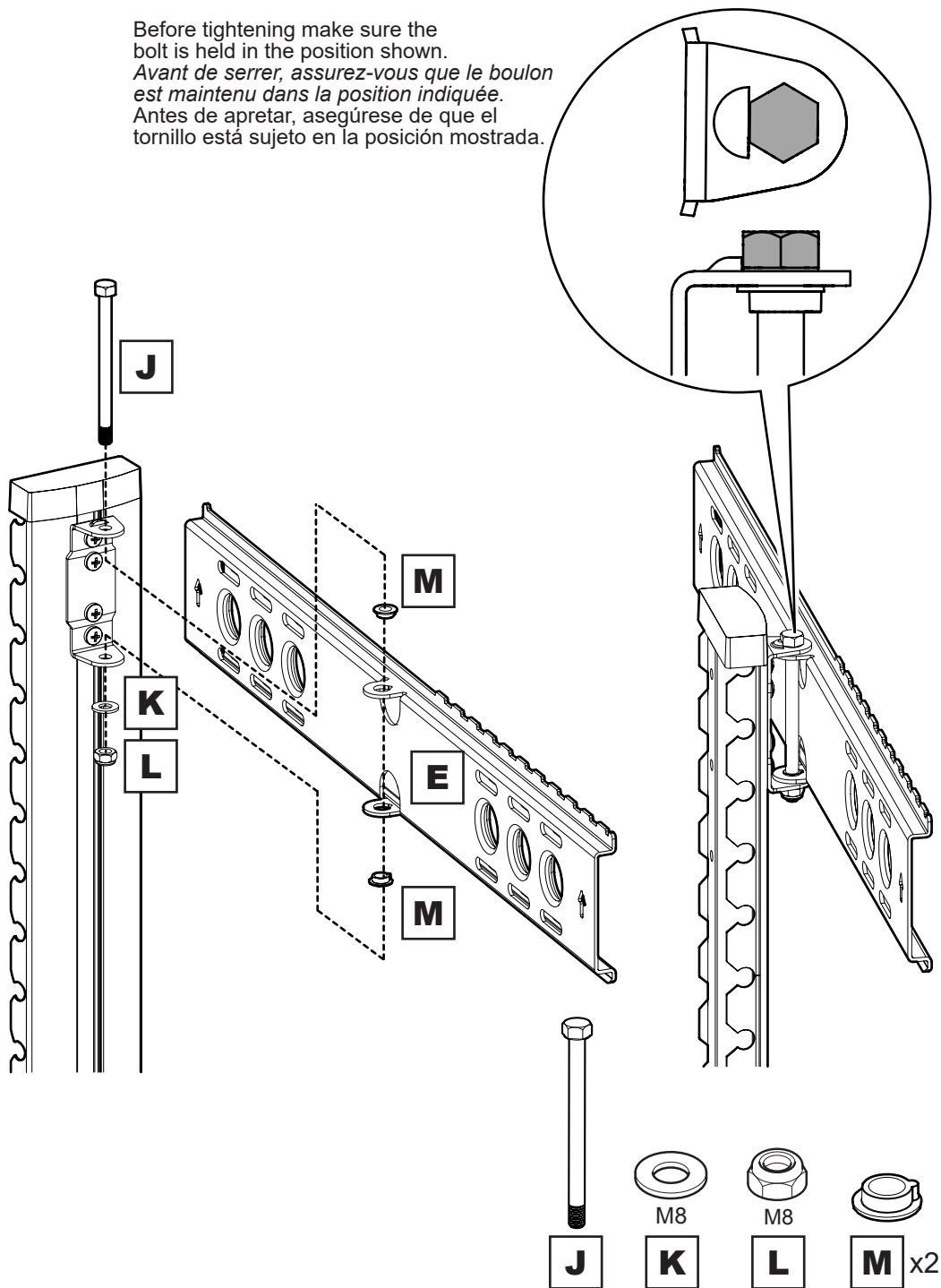

# 10

Fitting the Shelf  
Fixer la étagère  
Ajuste de la plataforma



DO NOT overtighten  
*Ne serrez pas trop fort*  
No apriete demasiado

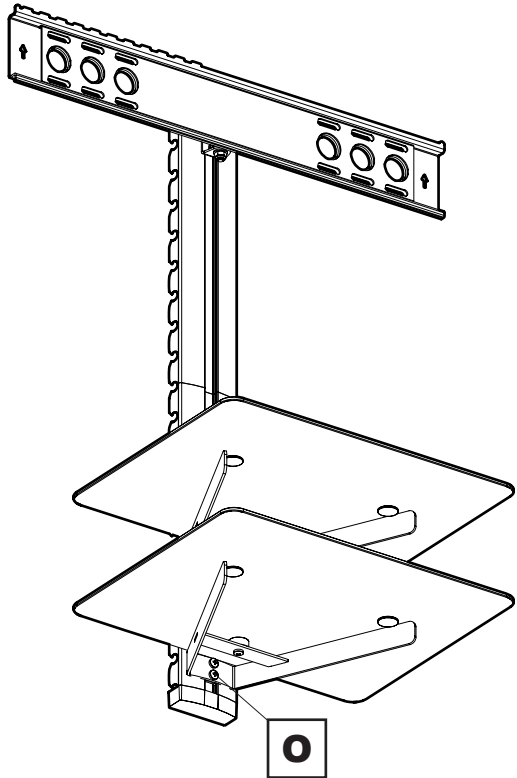
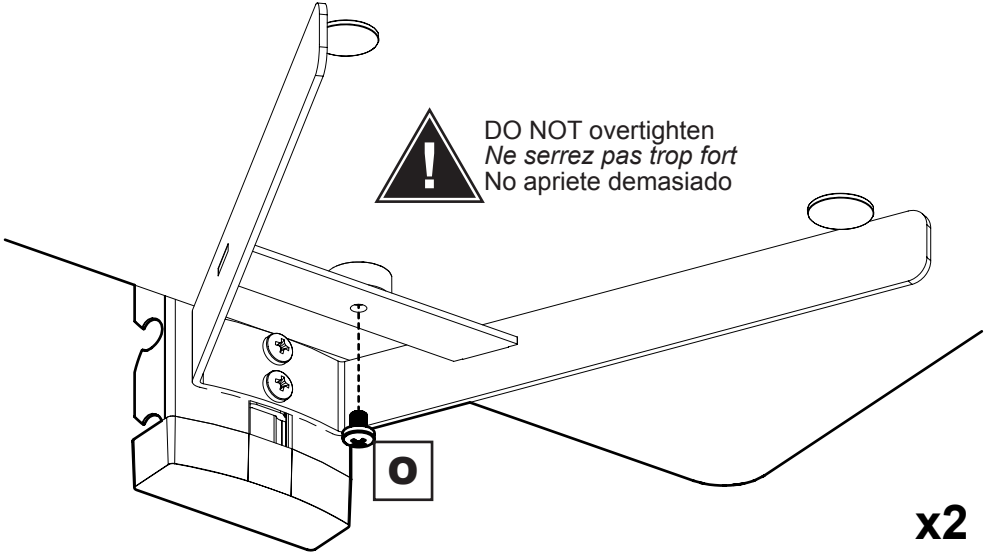

M6

8mm

**O** x2

**O**

**11**

Attach the TV  
Fixer la TV  
Coloque la TV

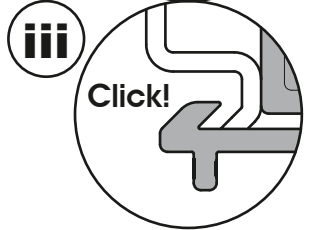
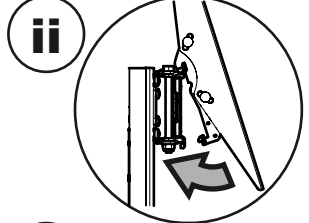
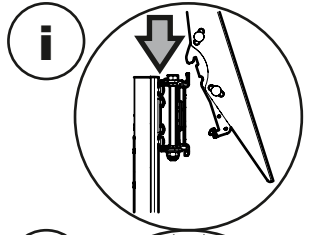
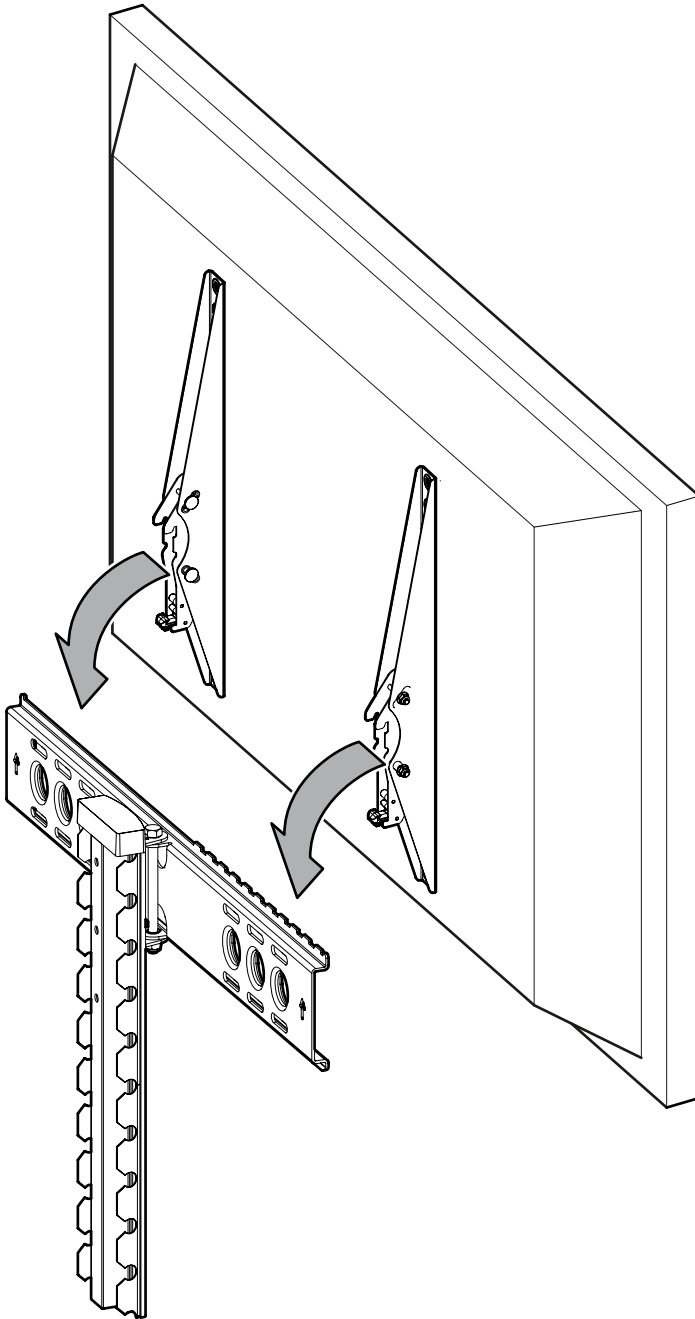

Optional  
Optionnel  
Opcional

Lock tilt  
Verrouiller l'inclinaison  
Cerradura de la función  
de inclinación

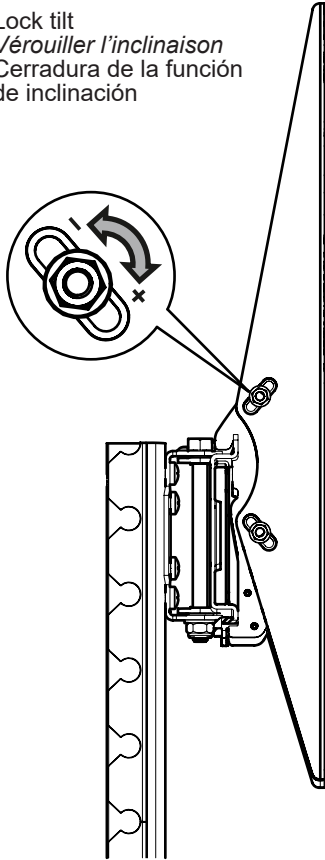

To remove TV  
Pour enlever le téléviseur  
Para quitar la TV

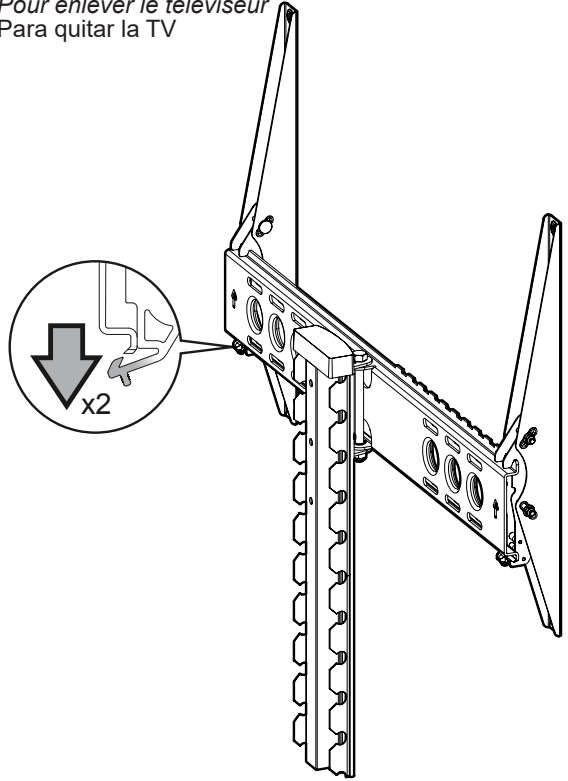

Adjustable  
Ajustable  
Ajustable

