

## NOTICE

- \* Please make sure that you have all parts indicated and they are in good condition before you begin assembly of this item. Refer to part list and hardware list below for guidance.
- \* This item should be assembled on a soft surface to prevent scratching the finish during assembly.
- \* This item may require periodic tightening.
- \* If you are having difficulty, our friendly Customer Care team is always here to help.

## PREPARATION

- \* Before beginning assembly of product, make sure all parts are present. Compare parts with part contents list and hardware contents list.
- \* If any part is missing or damaged, do not attempt to assemble the product.
- \* Estimated Assembly Time: 10 minutes.
- \* Tools Required for Assembly (included): None

## CARE AND MAINTENANCE

Adhesive felt pads should always be applied to areas of furniture which make direct contact with flooring, said application will prevent damage to the furniture and or surfaces on which the furniture lies. Objects placed on articles of furniture should rest on non abrasive material as to prevent damage to the wood finish. Objects whose composition consist of plastic and rubber are known to discolor and damage the wood surfaces on which they rest. Wipe up spills immediately and avoid common hazards such as hot dishes, harsh solvents and abrasives. Cleaning should be done with a soft lint free cotton cloth dampened with water or furniture polish. On highly used surfaces we recommend applying a quality paste wax which should be used on a regular basis to provide additional protection from scratches and spills. How often you apply the wax depends on how much the furniture wears.

PRODUCT DIMENSION: 46.7" W X 19" L X 35.2" H



Weight Capacity: 450LBS  
WARNING: DO NOT STAND ON CHAIR

### Part List and Hardware List



PIECE	DESCRIPTION	PICTURE	QUANTITY
A	BACK FRAME		1X
B	LEFT LEG FRAME		1X
C	RIGHT LEG FRAME		1X
D	CROSSBAR		2X
E	CHAIR SEAT		1X
F	LEFT ARM		1X
G	RIGHT ARM		1X

PIECE	DESCRIPTION	PICTURE	QUANTITY
HW1	JCBC SCREW M6 X 35MM		12X
HW2	FLAT WASHER 1/4 X 16		2X
HW3	ALLEN KEY M4		1X
HW4	WOOD SCREW M5 X 30MM		6X
HW5	SPRING WASHER M6 X 1/4		2X
HW6	GLUE		1X
HW7	FOOT PAD		4X

# PREPARATION

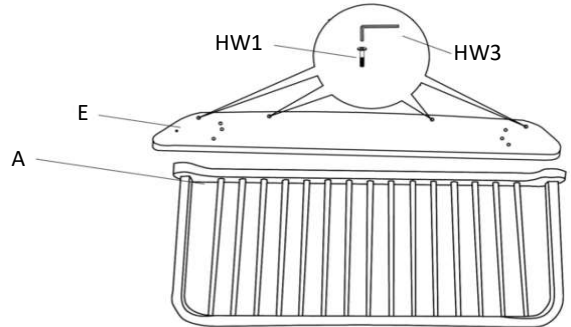
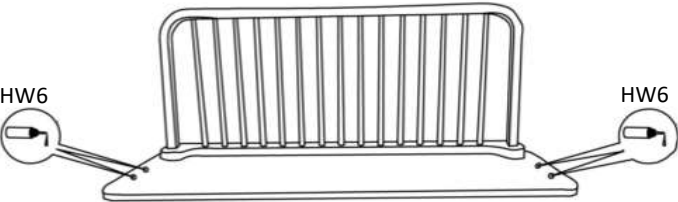
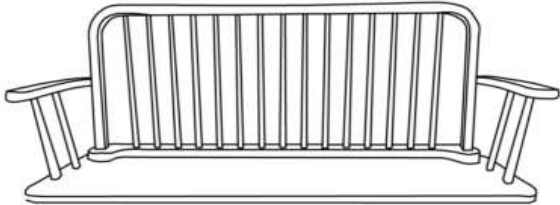
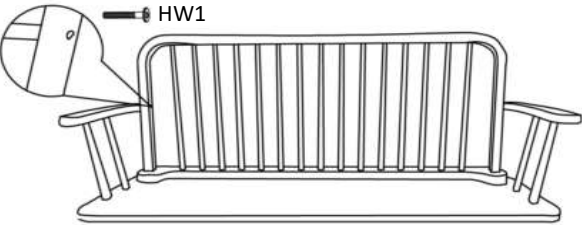
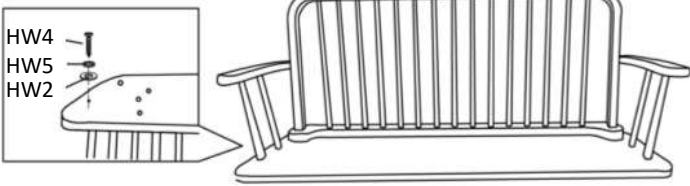
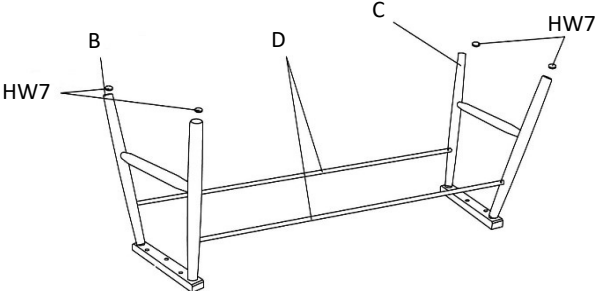
- \* Before beginning assembly of product, make sure all parts are present. Compare parts with part contents list and hardware contents list.
- \* If any part is missing or damaged, do not attempt to assemble the product.
- \* Estimated Assembly Time: 10 minutes.
- \* Tools Required for Assembly (included): None
- \* If you are having difficulty, our friendly Customer Care team is always here to help.

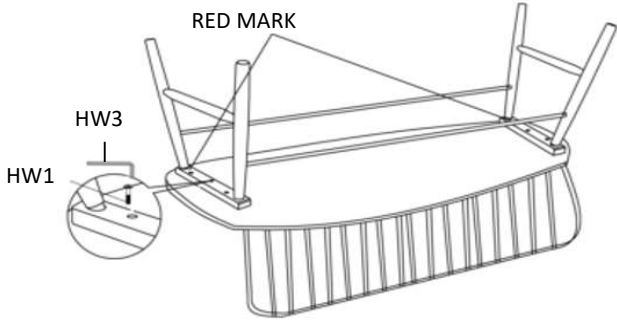
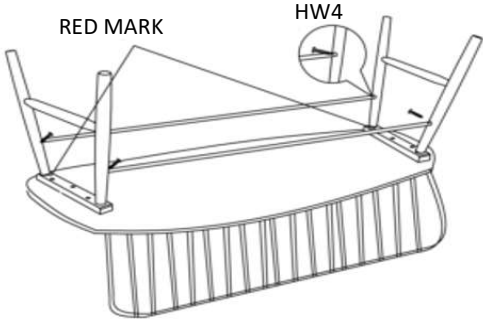
		
<p><b>STEP 1:</b> Attach the Back Frame (A) to the Chair Seat (E). Secure it using JCBC Bolt (HW1) with Allen Key (HW3). DO NOT TIGHTEN COMPLETELY AT THIS TIME</p>	<p><b>STEP 2:</b> Put the Glue (HW6) into the arm hole.</p>	<p><b>STEP 3:</b> Attach the Left Arm (F) &amp; Right Arm (G) into the Chair Seat (E) and the Back Frame (A).</p>
		
<p><b>STEP 4:</b> Secure it using JCBC Bolt (HW1) From side post.</p>	<p><b>STEP 5:</b> Using Wood Screw (HW4), Spring Washer (HW5) and Flat Washer (HW2) from the bottom of chair seat. Tighten all screws and bolts from step 1 to step 5 at this time. Do not over tighten and do not use power tools.</p>	<p><b>STEP 6:</b> Install Crossbar (D) into holes on Left Leg Frame (B) and Right Leg Frame (C). Paste the Foot Pad (HW7) to the legs.</p>

		
<p><b>STEP 7:</b> Front legs with RED MARK must facing front. Position the frame assembly into the bottom of Chair Seat. Align and tighten bolt into Chair Seat and frame using JCBC Bolt (HW1) with Allen Key (HW3).</p>	<p><b>STEP 8:</b> Front legs with RED MARK must facing front. Assembly Crossbar (D), Left Leg Frame and Right Leg Frame using Wood Screw(HW4).</p>	<p>Complete.</p>