

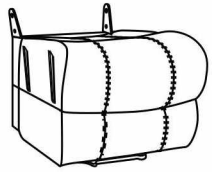







Electric Lift Chair Assembly Instruction_5058-A#

								
Chair base	Backrest	Left Armrest	Right Armrest	Power cord	Massage Remote	Chair Remote	Power Source	Power Source

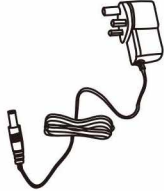
STEP 1

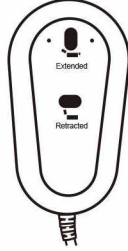

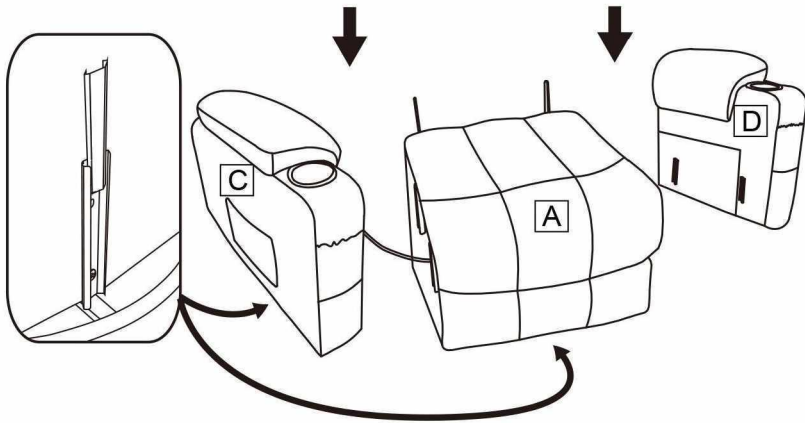
Insert two armrests to the chair base, make sure the slots on the armrests fully assembled to the bottom part.

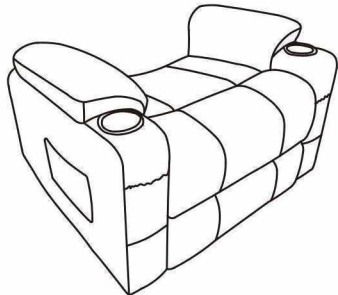

STEP 2

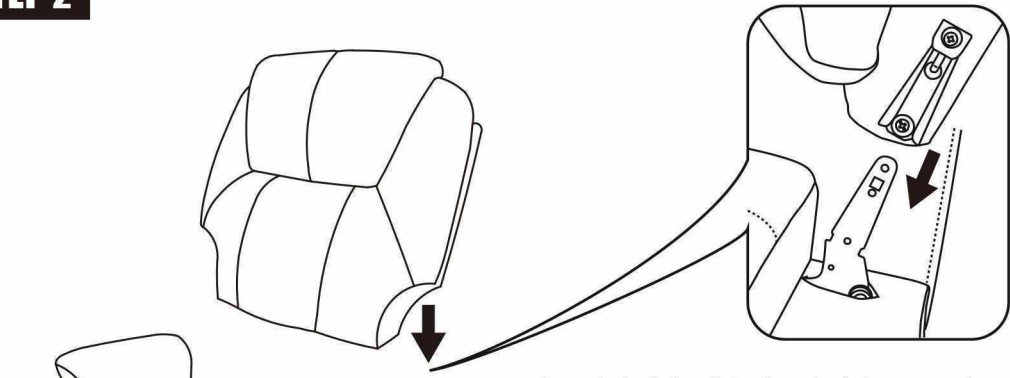

Insert chair back to the chair base, make sure the slots on the back fully assembled to the bottom part.

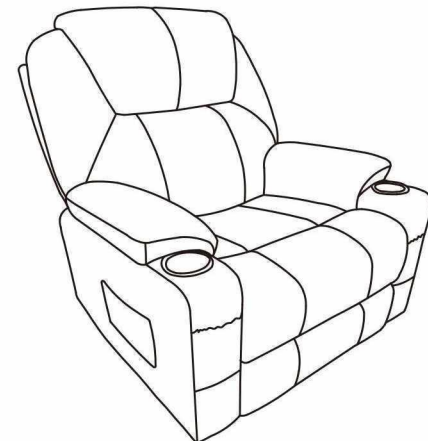
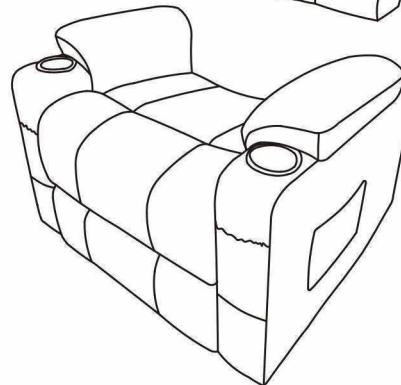

**UK
CA**

Electric Lift Chair Assembly Instruction_5058-A#

STEP 3

- No.1 and No.2 wire connect with the backrest and chair base.
- No.3 wire connects with backrest and power cord(E).
- No.4 wire connects with backrest and remote control(F).
- No.5 wire connect the motor and the wire from Chair Remote(G), which use to connect the control panel.
- No.6 wire connect the motor and power source (H).

NOTE

- 1: Two same color wires connect.
- 2: Plug power cord and power source into outlet, then you can use all function.

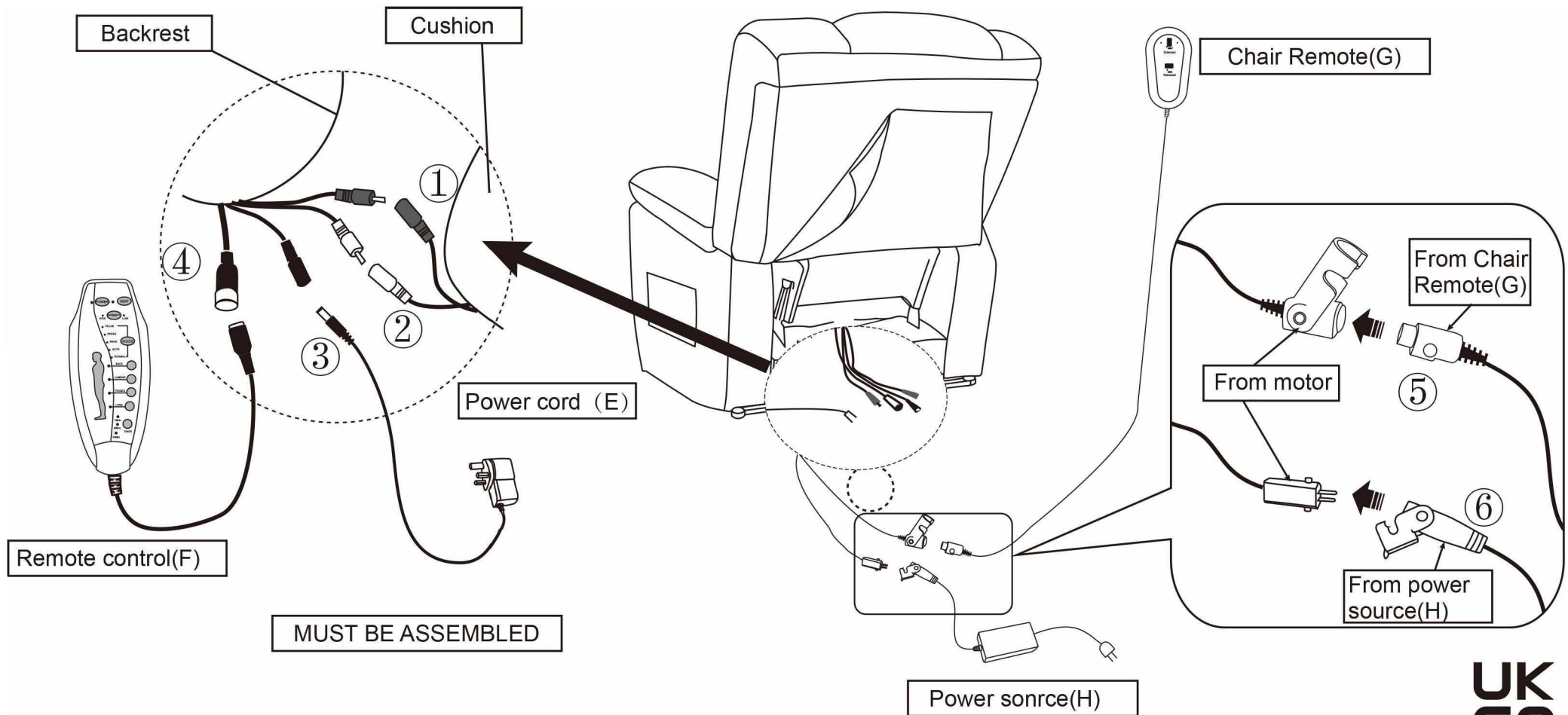

Electric Lift Chair Assembly Instruction_5058-A#

How to recline?

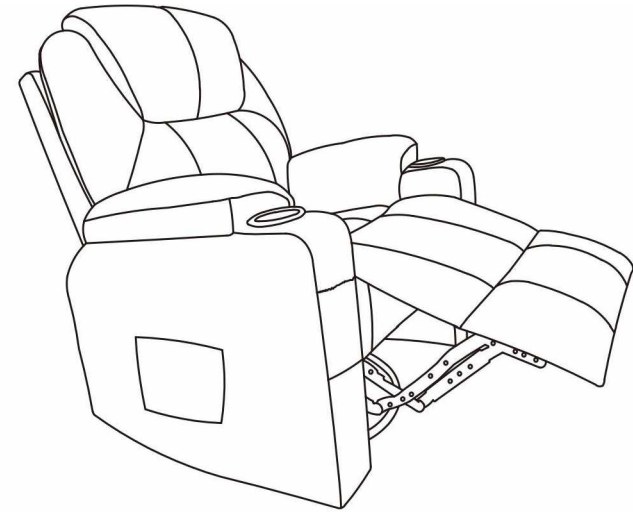
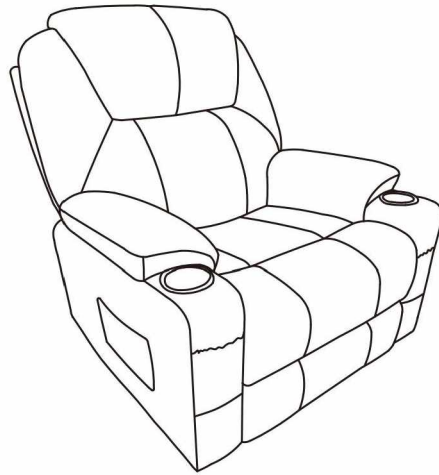
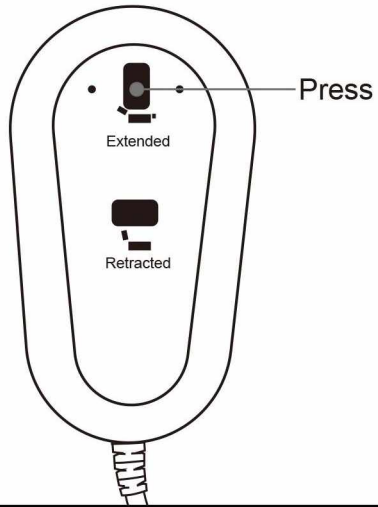

How to get footrest latch down and stand?

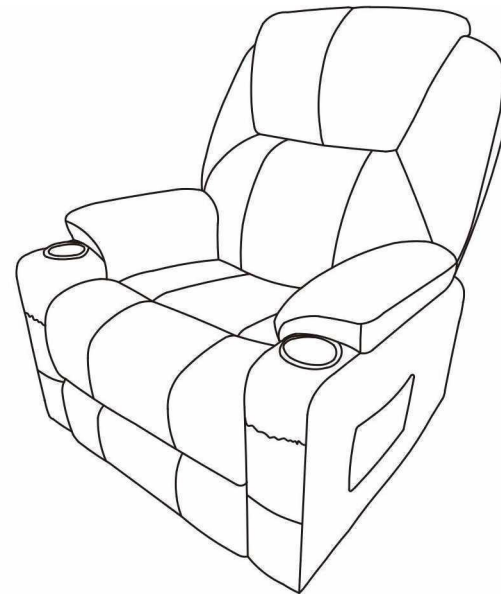
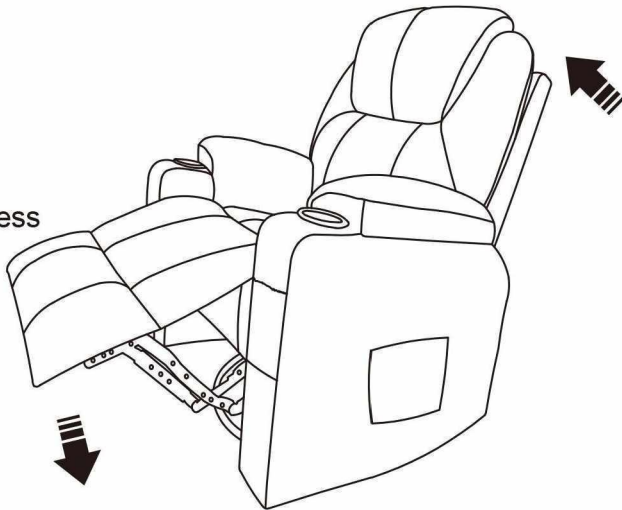
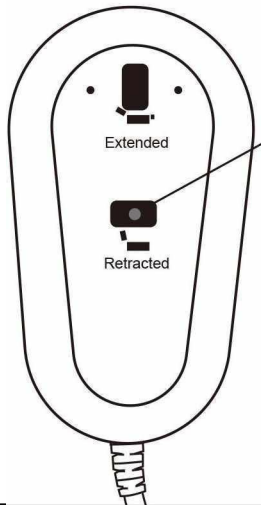

UK
CA

How to use remote control?

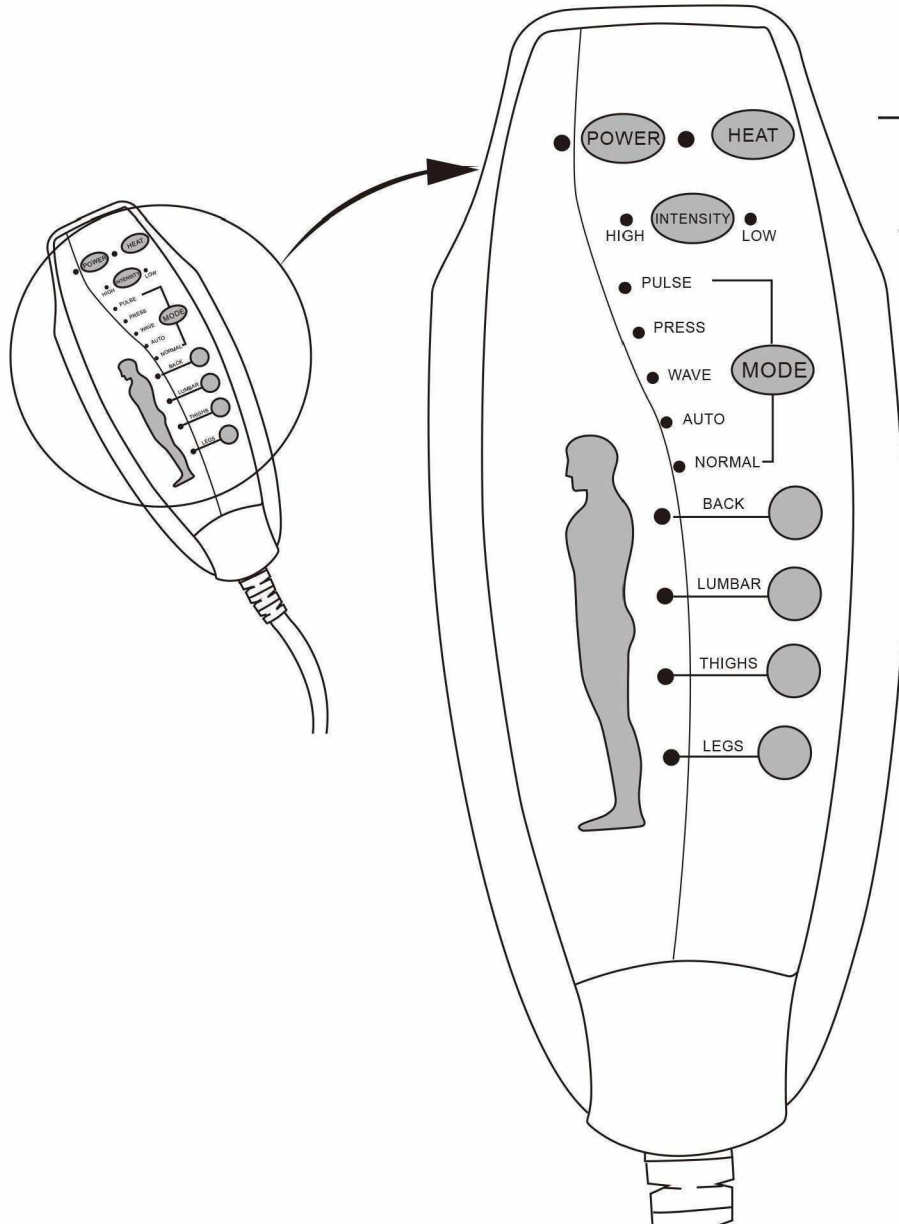

- POWER : Turn on/off remote control.
- HEAT : Turn on/off heat function for lumbar part only.
- INTENSITY : Control massage function from low to high.
- MODE : Choose one massage mode you like (pulse, press, wave, auto, normal)
- You can choose 1-4 massage parts (back, lumbar, thighs, legs) to enjoy.