

ASSEMBLY INSTRUCTION

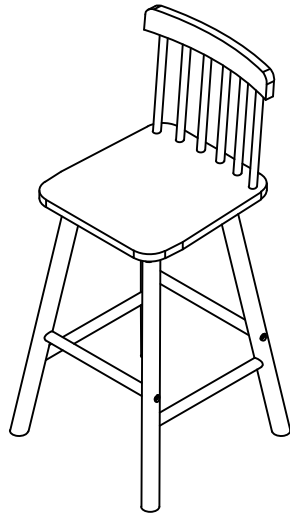

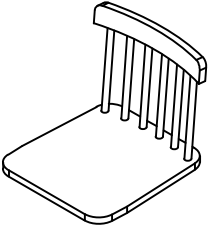

Counter Stool

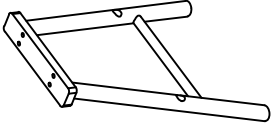
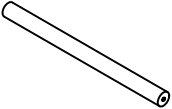

Component List

LABEL	SPARE PARTS	DESCRIPTION	QTY
A		Seat	1
B		Base Side Frame	2
C		Center Support	2

Hardware list

LABEL	SPARE PARTS	DESCRIPTION	SIZE	QTY
H1		Bolt	M8*40mm	8
H2		Bolt	M6*35mm	4
H3		Allen wrench	M5	1
H4		Flat Washer	Ø12*Ø6mm	4

Assembly Steps

1

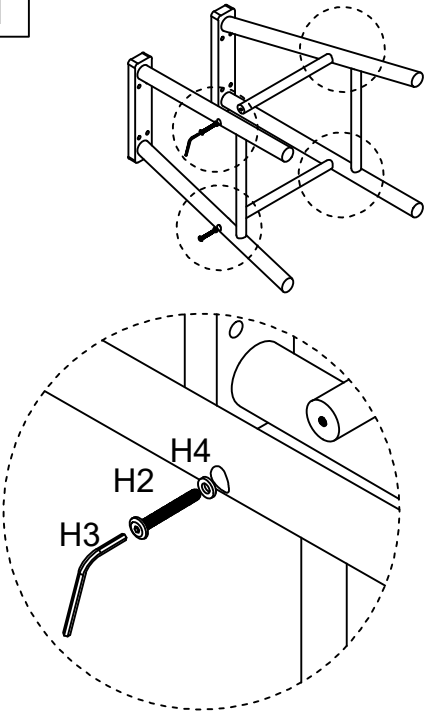

1.Put the legs on the floor and bolt in the center support 60% to assemble the leg frame.

2

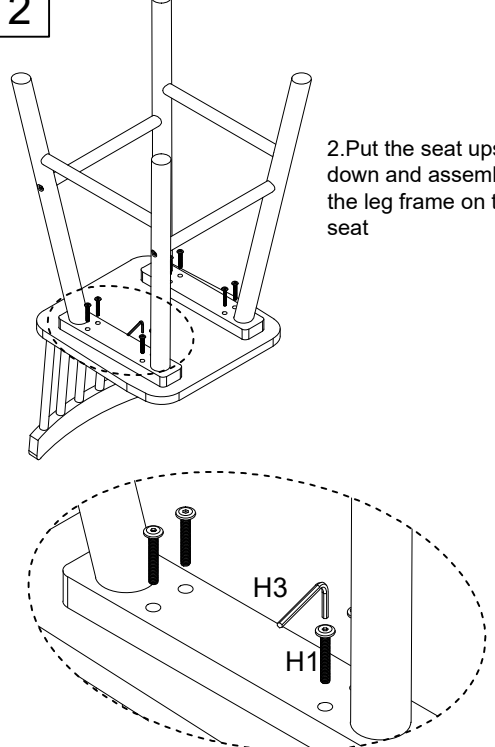

2.Put the seat upside down and assemble the leg frame on the seat

3

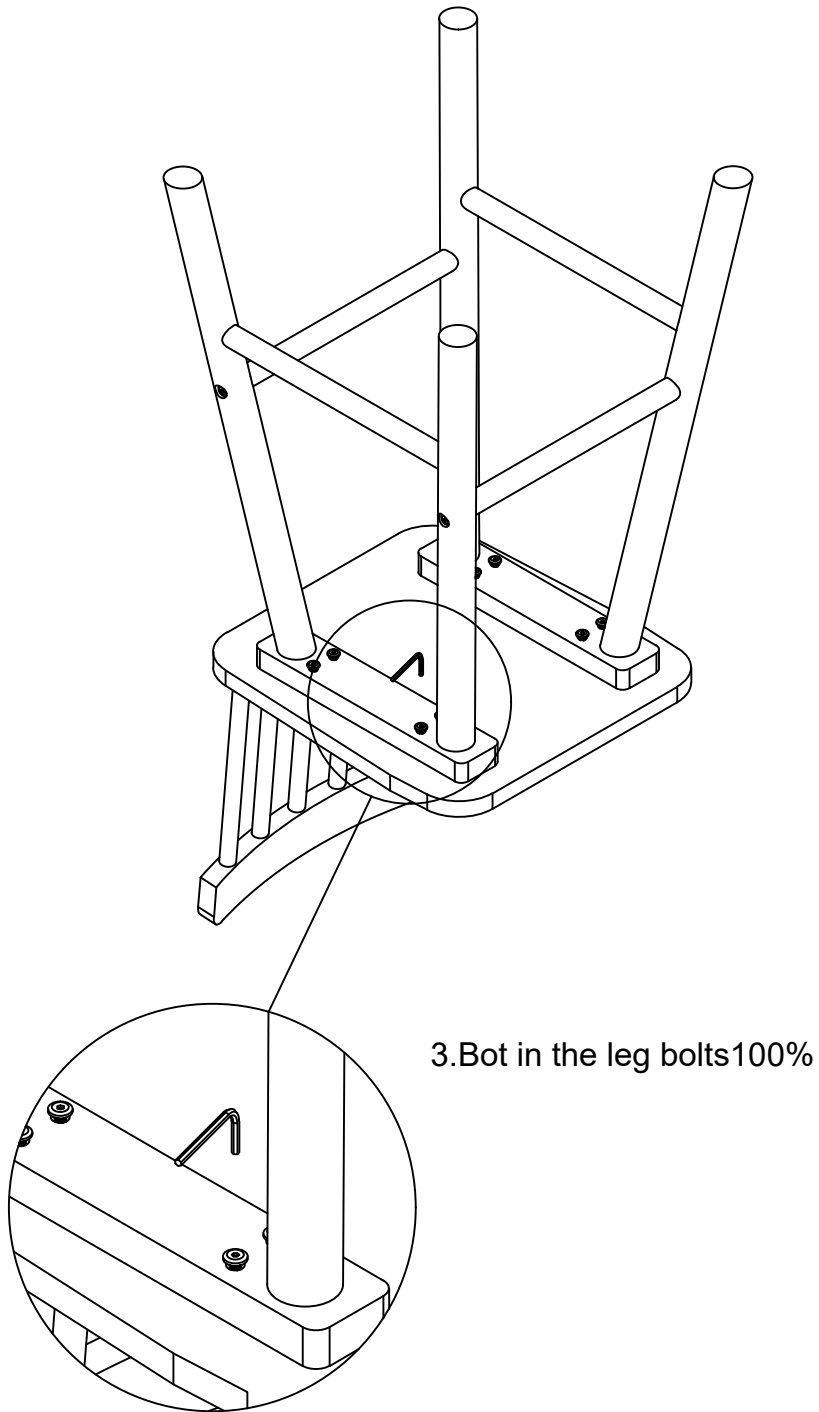

4

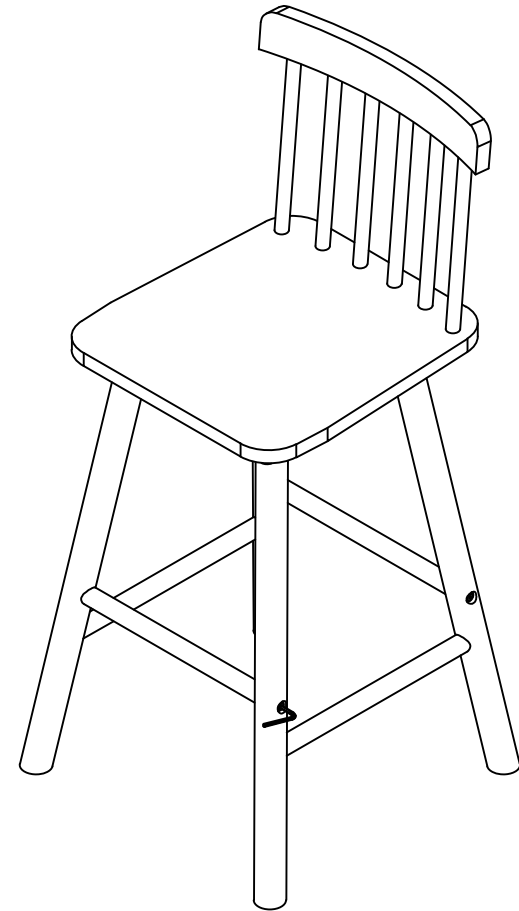

4. put the chair upstraight.