

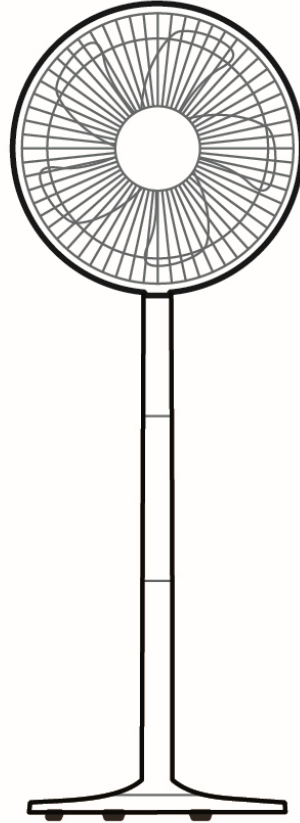

Russell Hobbs

Operating Manual for RHMPF3IN1 (B)



**REGISTER TODAY
FOR YOUR FREE
ADDITIONAL YEAR
GUARANTEE**

GUARANTEE

At Russell Hobbs, we take all our customer feedback seriously.

Feel free to contact our Product Care Team, on **0345 209 7461** who will be more than happy to assist you.

This product is guaranteed for 12 months from the date of the original purchase. If any defect arises due to faulty materials or workmanship, the faulty product must be returned to the place of purchase.

Refund or replacement is at the discretion of the retailer.

The following conditions apply:

- The product must be returned to the retailer with the original proof of purchase.
- The product must be installed and used in accordance with the instructions contained in this instruction guide and any other instructions for use which are supplied.
- It must be used for domestic purposes only and for its intended use.
- This guarantee does not cover wear and tear, damage, misuse or consumable parts.
- This does not affect your statutory rights.

RUSSELL HOBBS CONTACT DETAILS

Website: mda.russellhobbs.com

Telephone: 0345 209 7461

Address: Product Care, Green Bank Business Park,
Hindley Green, Wigan, WN2 4AY

Note your serial number below for future reference.



Image for illustration purposes only

REGISTER ONLINE

Visit our website to register your full parts and labour guarantee online.

mda.russellhobbs.com

REGISTER BY PHONE

Call our friendly Product Care team on the number below.

0345 209 7461

IMPORTANT SAFETY INSTRUCTIONS

- It is hazardous for anyone other than a competent person to carry out any service or repair operation that involves the removal of a cover which gives protection against exposure to electrical parts.
- Do not use with a damaged cord or plug. If the supply cord is damaged, it must be replaced by the manufacturer, its service agent or similarly qualified persons in order to avoid a hazard.
- This product is intended for household use only.
- Do not use outdoors.
- This appliance can be used by children aged from 8 years and above and persons with reduced physical, sensory or mental capabilities or lack of experience and knowledge if they have been given supervision or instruction concerning use of the appliance in a safe way and understand the hazards involved. Children should not play with the appliance. Cleaning and user maintenance should not be made by children without supervision.
- Do not operate this appliance for anything other than its intended use.
- Do not immerse whole unit in water or other liquids for cleaning.
- Unplug from outlet when not in use. Do not leave unattended while plugged in.
- Do not use if it has been dropped, damaged, left outdoors or dropped into water.
- Keep the appliance away from water; do not allow it to get wet. If unit is wet, do not plug unit into wall socket or turn unit on.

IMPORTANT SAFETY INSTRUCTIONS

- Do not handle the appliance with wet hands.
- Do not pull or carry by cord, use cord as a handle, close door on cord, pull cord around sharp corners or edges, or expose cord to heated surfaces. Do not unplug by pulling on cord.
- To protect against electrical shock do not immerse cord, plug, or appliance in water or other liquid.
- Unplug from the mains outlet when not in use, before putting on and taking off parts, and before cleaning.
- Only use the unit when fully assembled.
- Never place your fingers or other objects into any part of the appliance. Be aware that loose clothing or hair may become trapped in the appliance if improperly used.
- Before use, ensure that all of the air vents of the appliance are clear and there is no restriction of air flow.
- Caution: Appliance may disturb ashes in an open fire. Always avoid directing the appliance toward naked flames.

PARTS

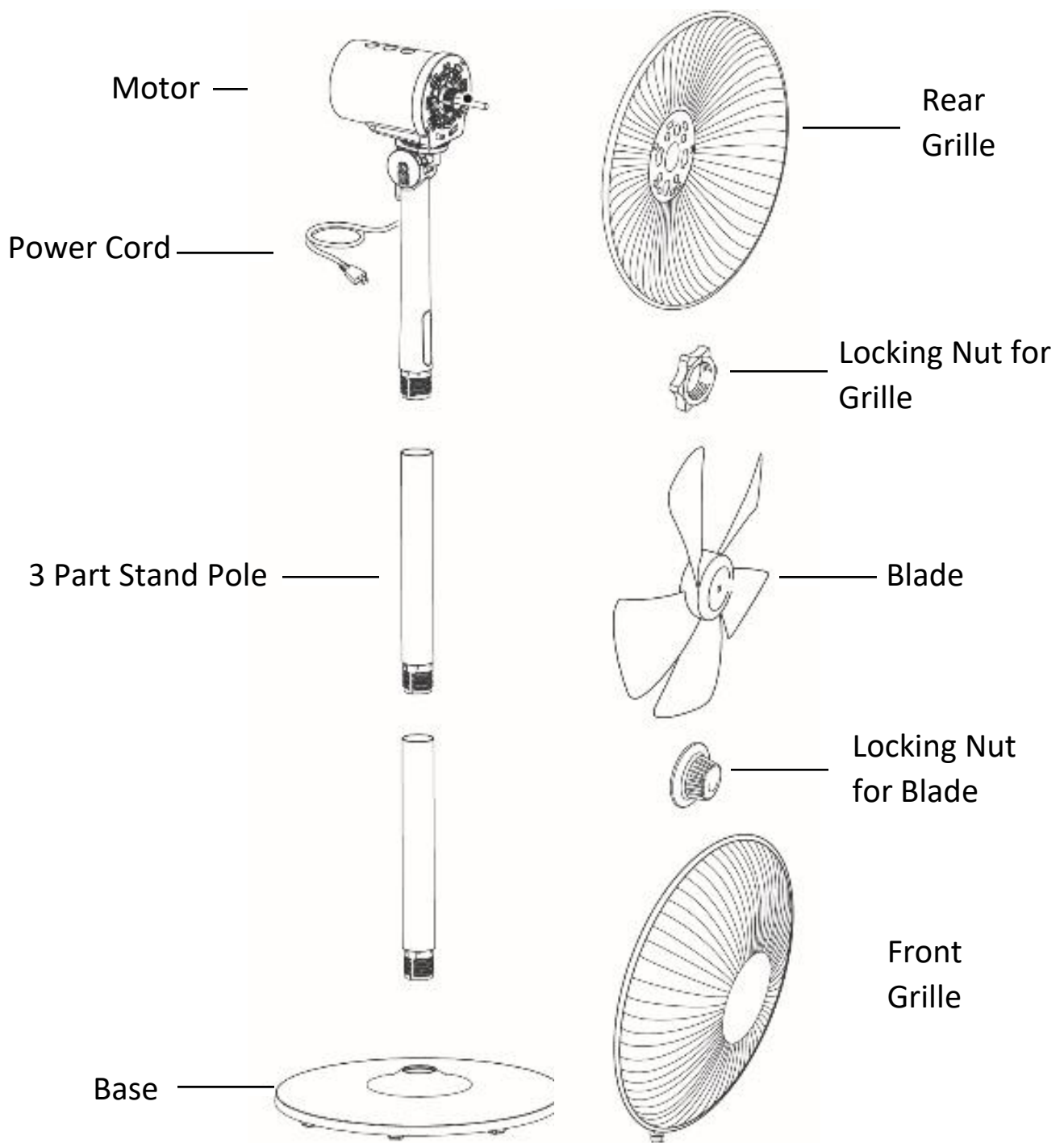

ASSEMBLY

1. Align a pole with the hole in the base and rotate to fix into place.

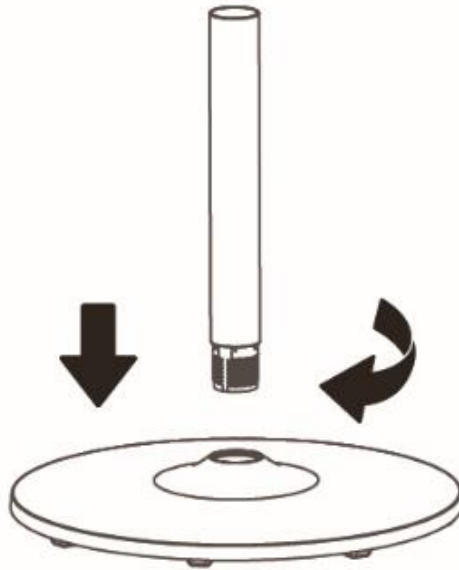

2. Align and rotate the second pole next and then pole with the fan body.

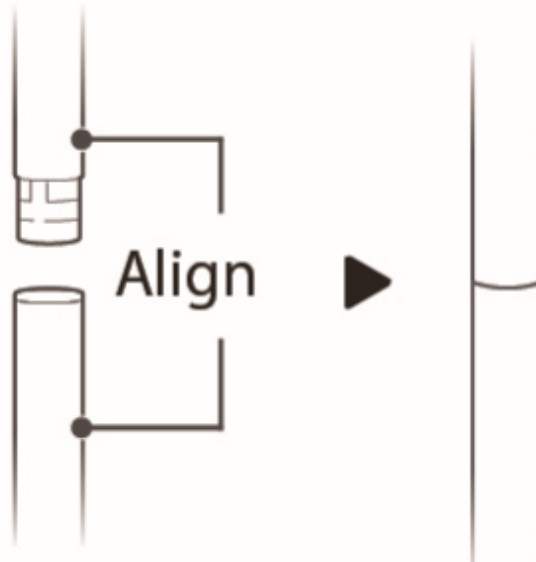

ASSEMBLY

3. Remove both locking nuts. Place the rear grille onto the motor shaft ensuring that the shaft points are aligned with the grille holes. Use the grille locking nut to fix the rear grille into place by turning clockwise.

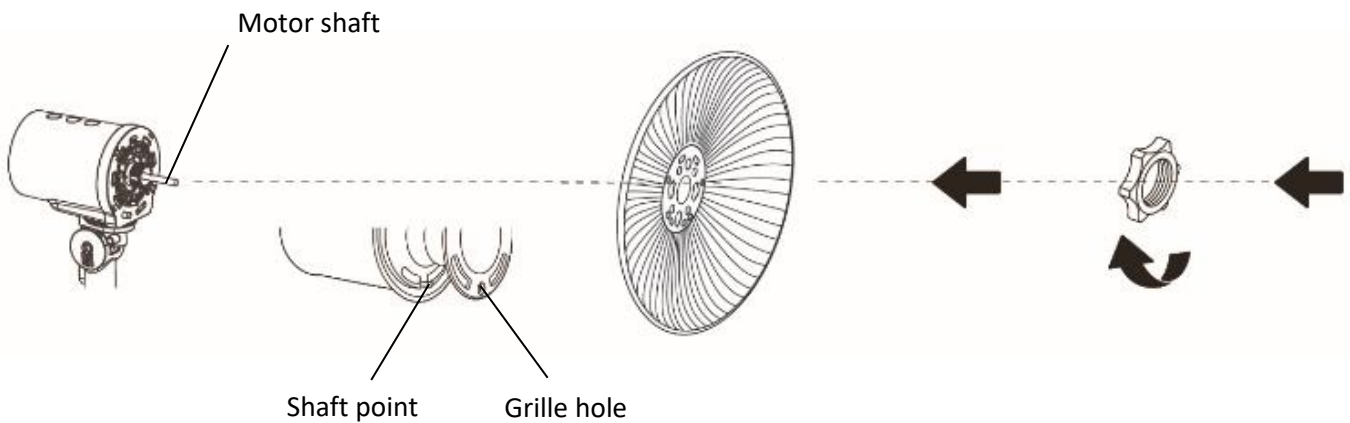

4. Place the blades over the motor shaft aligning the locator pins on the motor shaft with the blades base. Use the blade locking nut to fix the blades into place by turning anticlockwise. Turn the blades to ensure they spin freely.

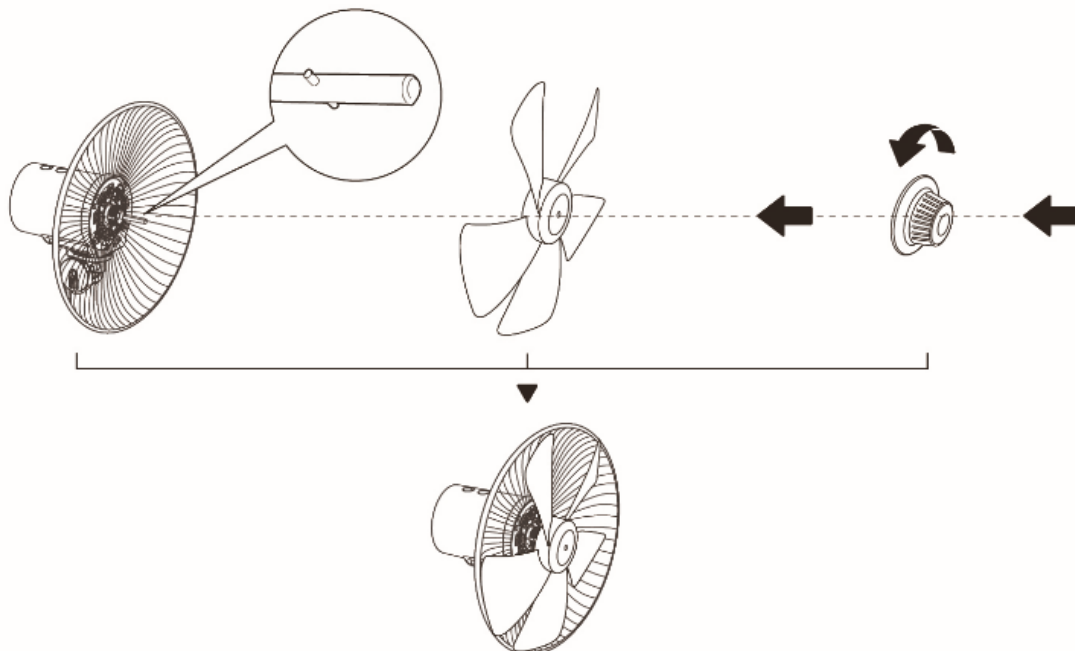

ASSEMBLY

6. Remove the screw from the catch on the front grille. Align the front grille catch with the rear grille catch and press guards together sequentially with both hands.

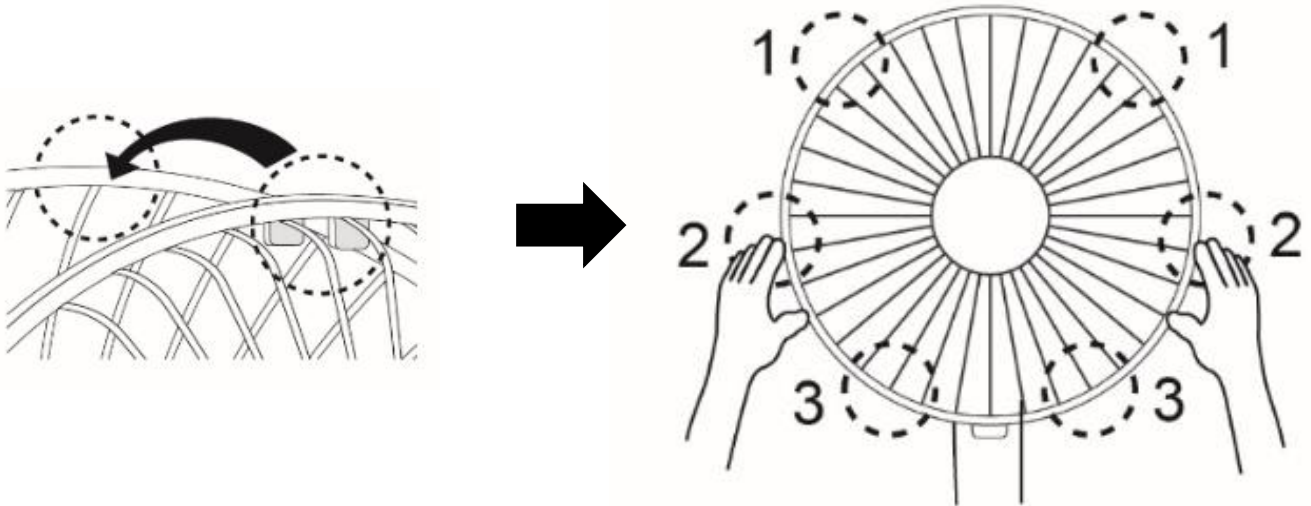

7. Replace the screw into the catch to secure the grilles.

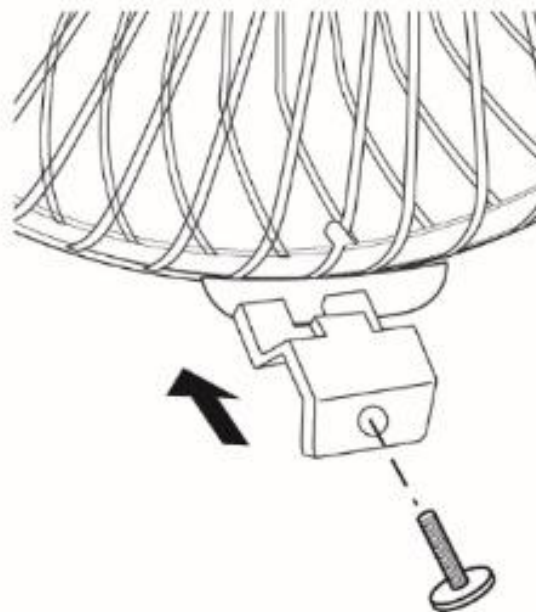

ADJUSTING YOUR FAN

The height can be adjusted into 3 different positions by removing 1 or 2 poles.

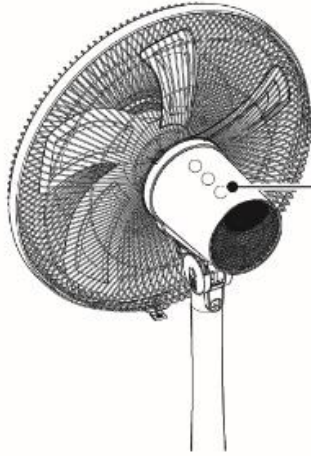
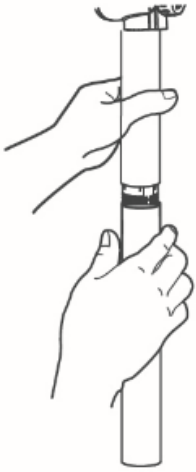

Manually adjust the angle of the air direction by tilting the motor

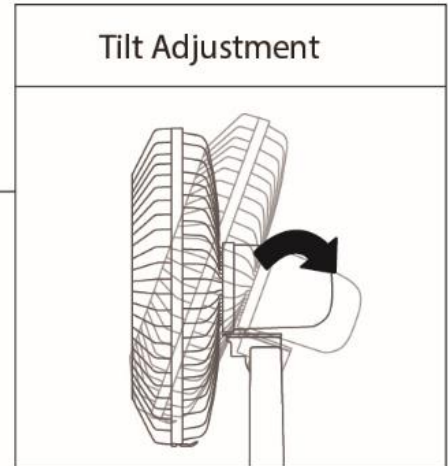

USING YOUR FAN



On/Off Press this key to stop/start your fan



Oscillating When the fan is turned on, press this key to begin oscillation.



Wind Speed When the fan is turned on, press this key to circulate between the 8 blade speed settings.

To set the power off timer, press and hold this key for 2 seconds and then a short press for 1 hour, 2 short presses for 2 hours, etc for up to 8 hours.



Timer Your remote control has a separate key to control the timer in the same manner as above.

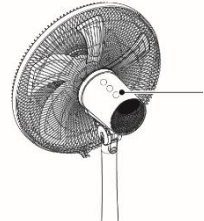
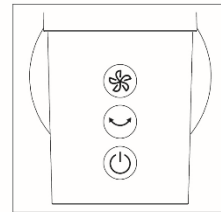

Note: Use the remote within a 5m radius.

2 x AAA batteries

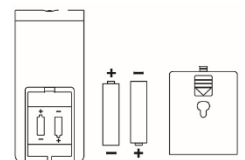
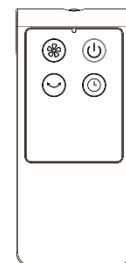

PROBLEM SOLVING

The fan doesn't switch on	<ul style="list-style-type: none">• Check the fan is plugged in• Check the socket is switched on• Check another appliance in the socket• Unplug and check for any obvious signs of damage to cord or plug• If recently used, allow to cool for 1 hour then try again
The fan is rattling	<ul style="list-style-type: none">• Check the grille is secured properly• Check all screws are securely fastened• Check there is nothing in contact with the fan
Fan will not oscillate	<ul style="list-style-type: none">• Check the oscillation switch is pressed down• Check that nothing is interfering with the fan preventing oscillation
Fan is making a grinding sound	<ul style="list-style-type: none">• Immediately switch off and contact Customer Services
The air is dusty	<ul style="list-style-type: none">• Ensure fan is unplugged and set to 0• Carefully remove grille• Carefully remove blades from fan• Using mild soapy water and a sponge, gently rinse the blades• Allow to dry naturally for 24 hours then refit the blades

IMPORTANT!

KEEP BLADES CLEAN

Wash the blades with cold water at least once every 3 months.
The blades may require more frequent washing if in a dusty environment.

3

MONTHS



This product is guaranteed for 12 months from the date of the original purchase. If any defect arises due to faulty materials or workmanship, the faulty product must be returned to the place of purchase.

By registering your product you will get an additional year guarantee free of charge. Additional cover can be purchased through the website.

REGISTER ONLINE

Visit our website to register your full parts and labour guarantee online.

mda.russellhobbs.com

REGISTER BY PHONE

Call our friendly Product Care team on the number below.

0345 209 7461



Russell Hobbs

Russell Hobbs is a registered trademark used under license from Spectrum Brands (UK) Ltd. Made under license by Product Care Trading Limited, Wigan, WN2 4AY/ PCT (NI) Ltd, Belfast, BT5 5AD

Russell Hobbs Support: call 0345 209 7461 or visit
mda.russellhobbs.com

UK
CA

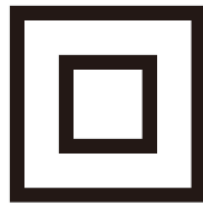

The 'wheeie bin' symbol is known as the 'Crossed-out wheeie bin Symbol'. When this symbol is marked on a product/batteries, it means that the product/batteries should not be disposed of with your general household waste. Only discard electrical/electronic/battery items in separate collection schemes, which cater for the recovery and recycling of materials contained within. Your co-operation is vital to ensure the success of these schemes and for the protection of the environment. For your nearest disposal facility, visit www.recycle-more.co.uk or ask in store for details.

SEDEX – Connecting businesses and their global suppliers to share ethical data and enabling improvement in ethical performance. Visit www.sedex.org.uk for further information.

We reserve the right, due to possible changes to design, to alter the instruction manual without prior notice.