

# ASSEMBLY INSTRUCTION

ITEM NUMBER:BD002

SIZE: Full/Queen

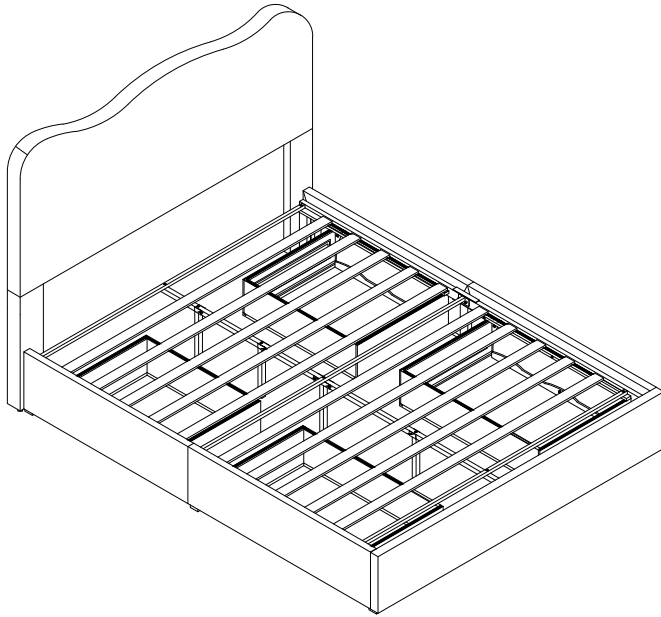

Please **TEAR OFF** this shrink film from side!  
**DO NOT USE CUTTER!**

## IMPORTANT NOTE

- 1. The product is shipped in two packages. Please check the number of packages received before assembly. If you are missing one package, receive a duplicate package, or have any assembly or after-sales issues, please contact [support@velocavabed.com](mailto:support@velocavabed.com)**
2. For the protection of your furniture, place all parts on a clean and smooth surface to prevent any damage.
3. Keep fittings out of children's reach and keep children well away from construction area.
4. When moving your assembled bed. it is best to lift the bed and never to drag it.
5. Do not use this product if parts are missing, damaged or worn.
6. This product should only be used on firm, level ground.
7. Please periodically check all fittings and re-tighten as necessary.
8. Do not use the bed unless all bolts and screws are firmly secured.
9. For further assistance, please provide a screenshot of your order and contact us via email at [support@velocavabed.com](mailto:support@velocavabed.com)

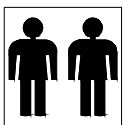

Minimum two  
person assembly

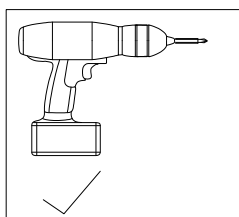



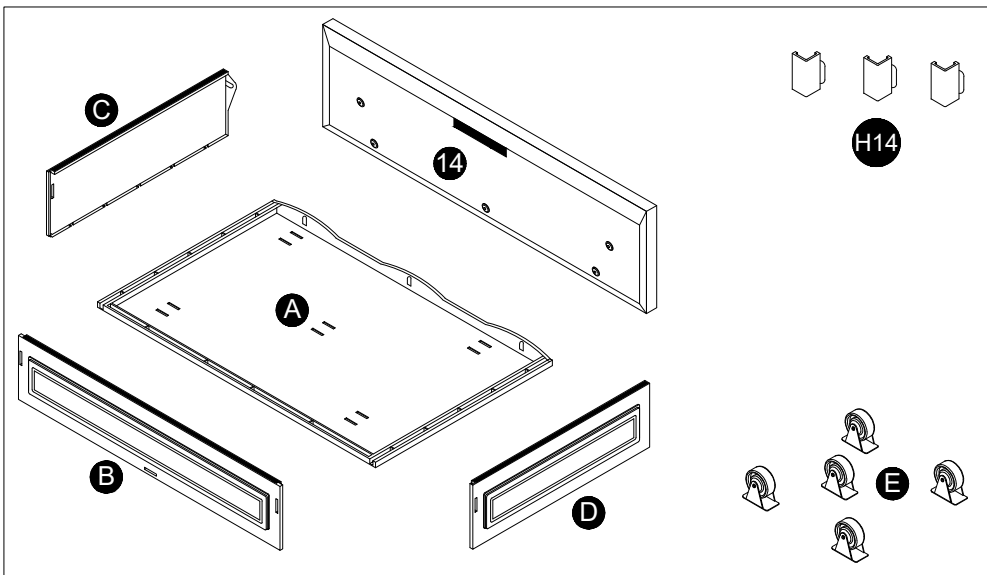
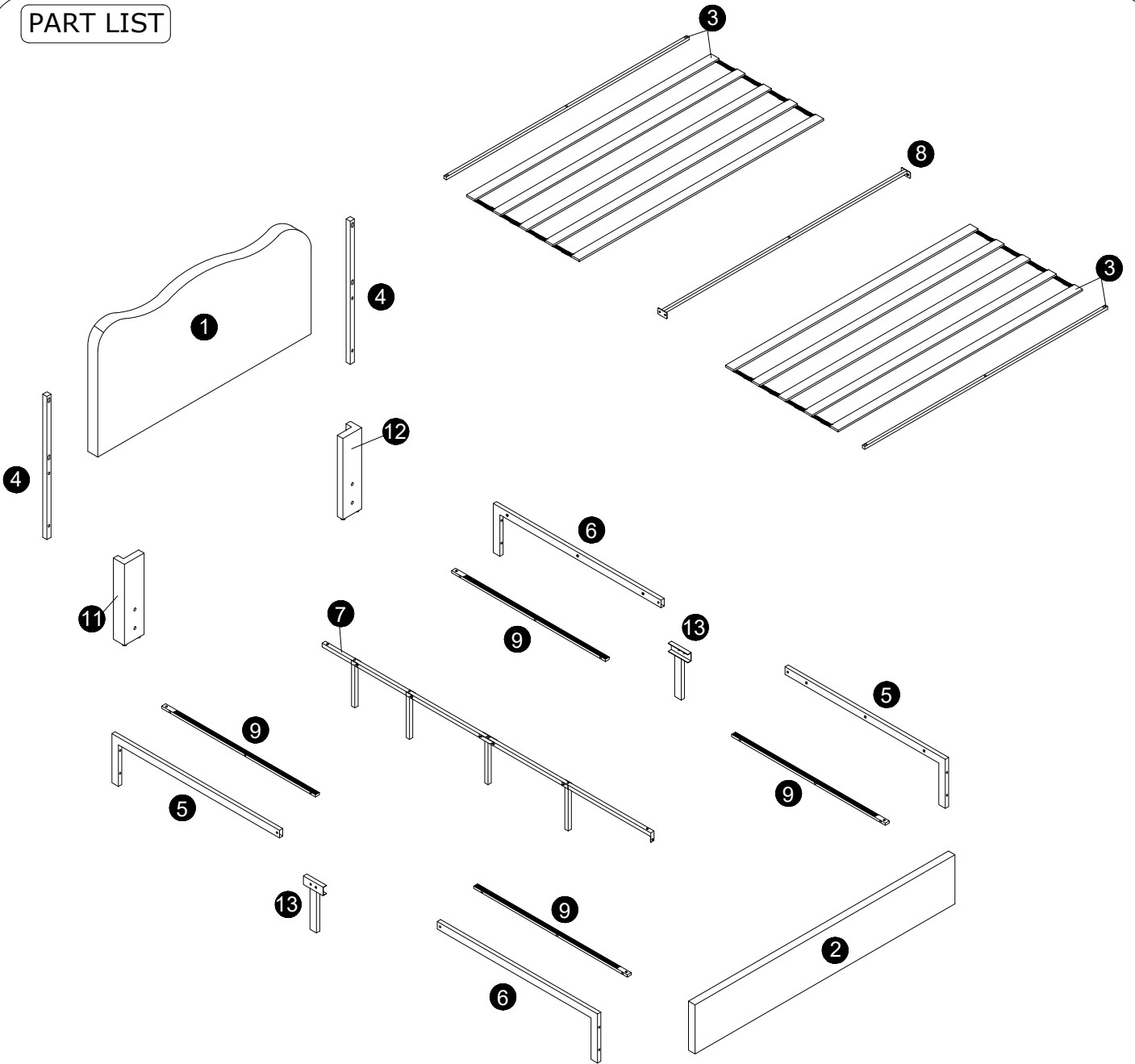



**PART LIST**

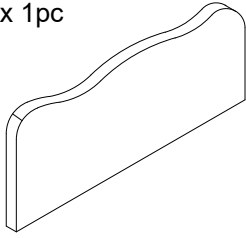
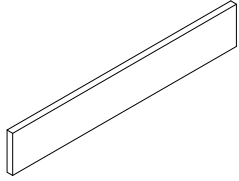
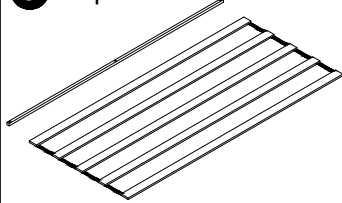

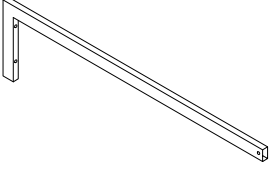
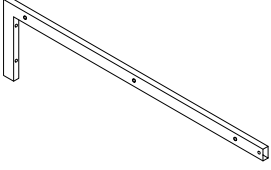
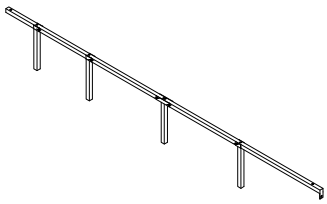
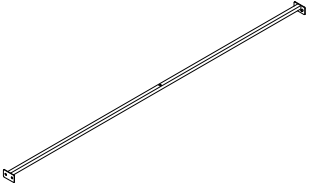
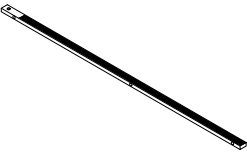
**x4**

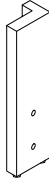
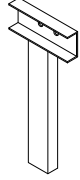
### Components of Carton A





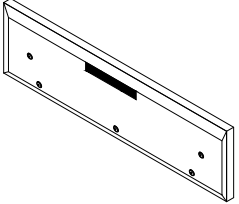
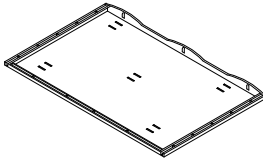
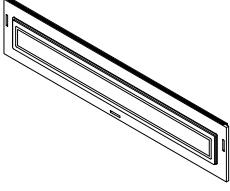
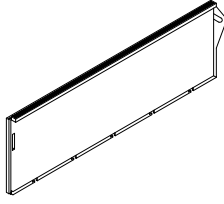
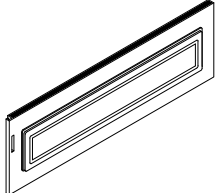



<b>1</b> x 1pc 	<b>2</b> x 1pc 	<b>3</b> x 2pcs 	<b>4</b> x 2pcs 
<b>5</b> x 2pcs 	<b>6</b> x 2pcs 	<b>7</b> x 1pc 	<b>8</b> x 1pc 
<b>9</b> x 4pcs 	<b>11</b> x 1pc 	<b>12</b> x 1pc 	<b>13</b> x 2pcs 
<b>E</b> x 20pcs 	<b>H14</b> x 12pcs 		

### Components of Carton B

<b>14</b> x 4pcs 	<b>A</b> x 4pcs 	<b>B</b> x 4pcs 	<b>C</b> x 4pcs 	<b>D</b> x 4pcs 
---	--	--	---	--

### HARDWARE LIST

### Components of Carton A

 <b>H1</b> M5 x 1pc	 <b>H2</b> M4 x 1pc	 <b>H3</b> M8x35mm x 19pcs	 <b>H4</b> M8x65mm x 8pcs
 <b>H5</b> M8x50mm x 8pcs	 <b>H7</b> M6x35mm x 7pcs	 <b>H8</b> M6x60mm x 1pc	 <b>H9</b> M6x15mm x 20pcs

**Please ensure to thoroughly inspect the small inner cardboard box containing the hardware, which are tied with a red string, before disposing of the box.**

1

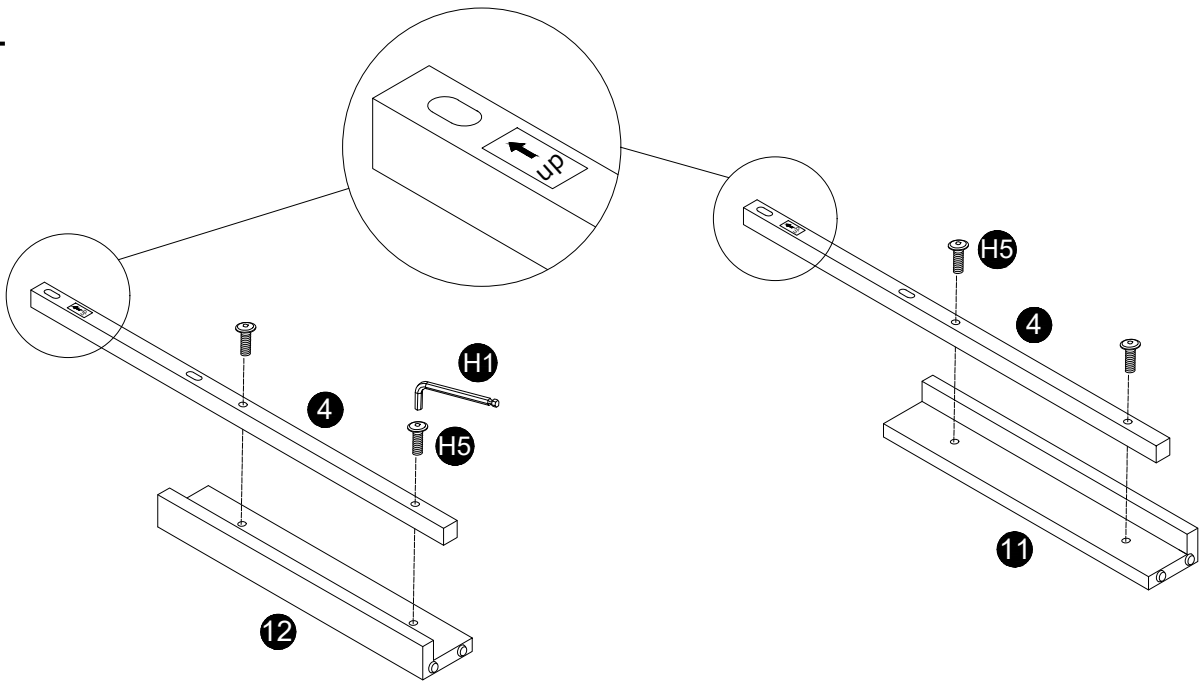

2

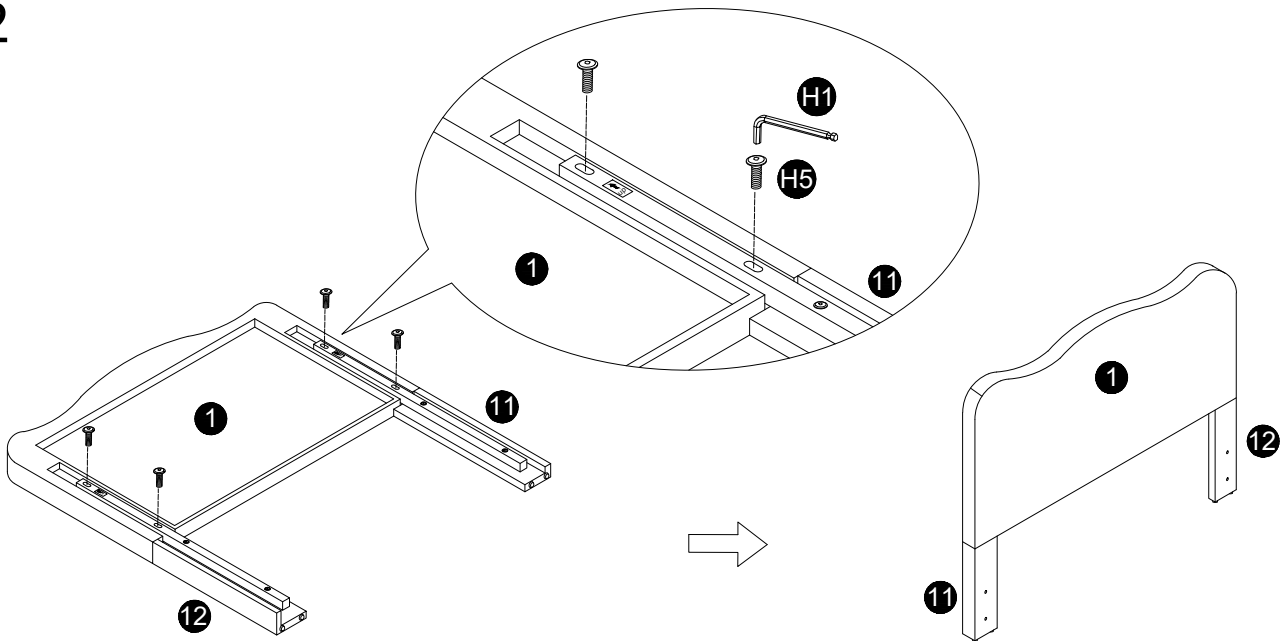

3

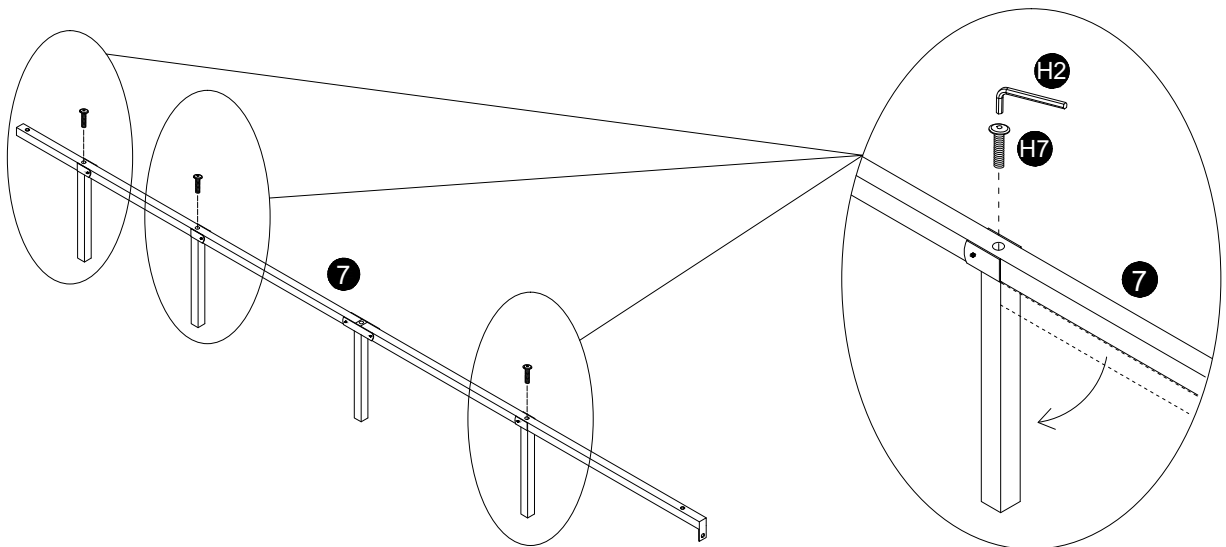

4

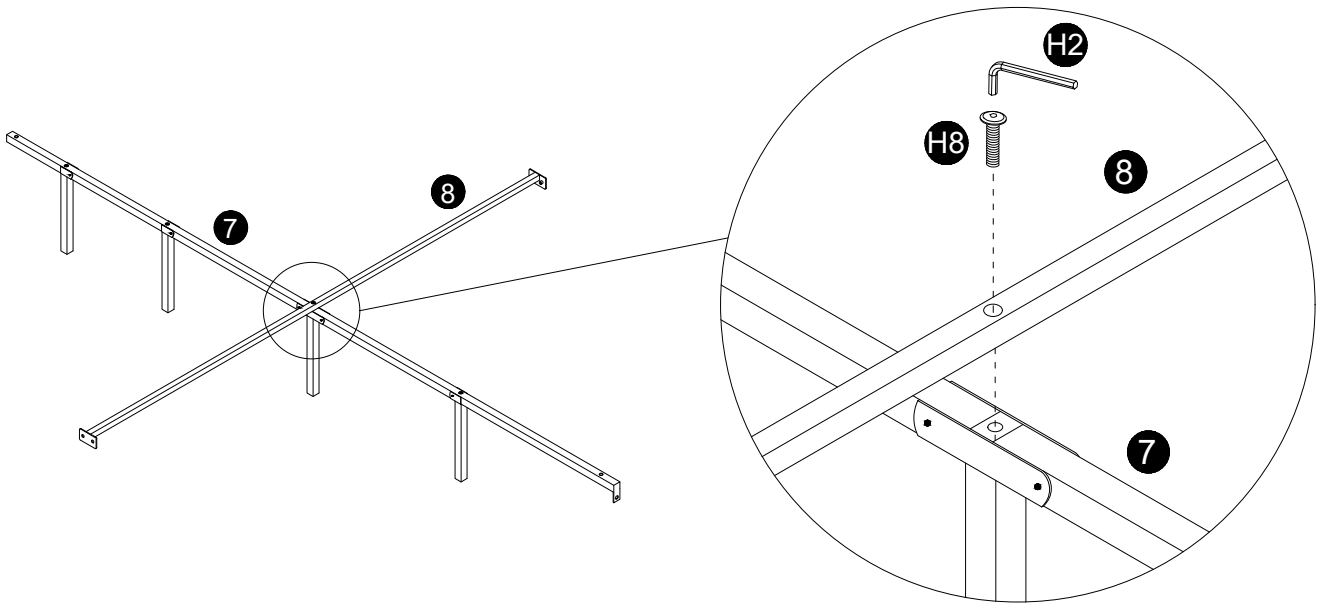

5

Please attention when assembling the part number 8, please first pass the part number 5 / 6 through the part number 13 and the alignment hole, and then connect the part number 8 to the alignment hole assembly.

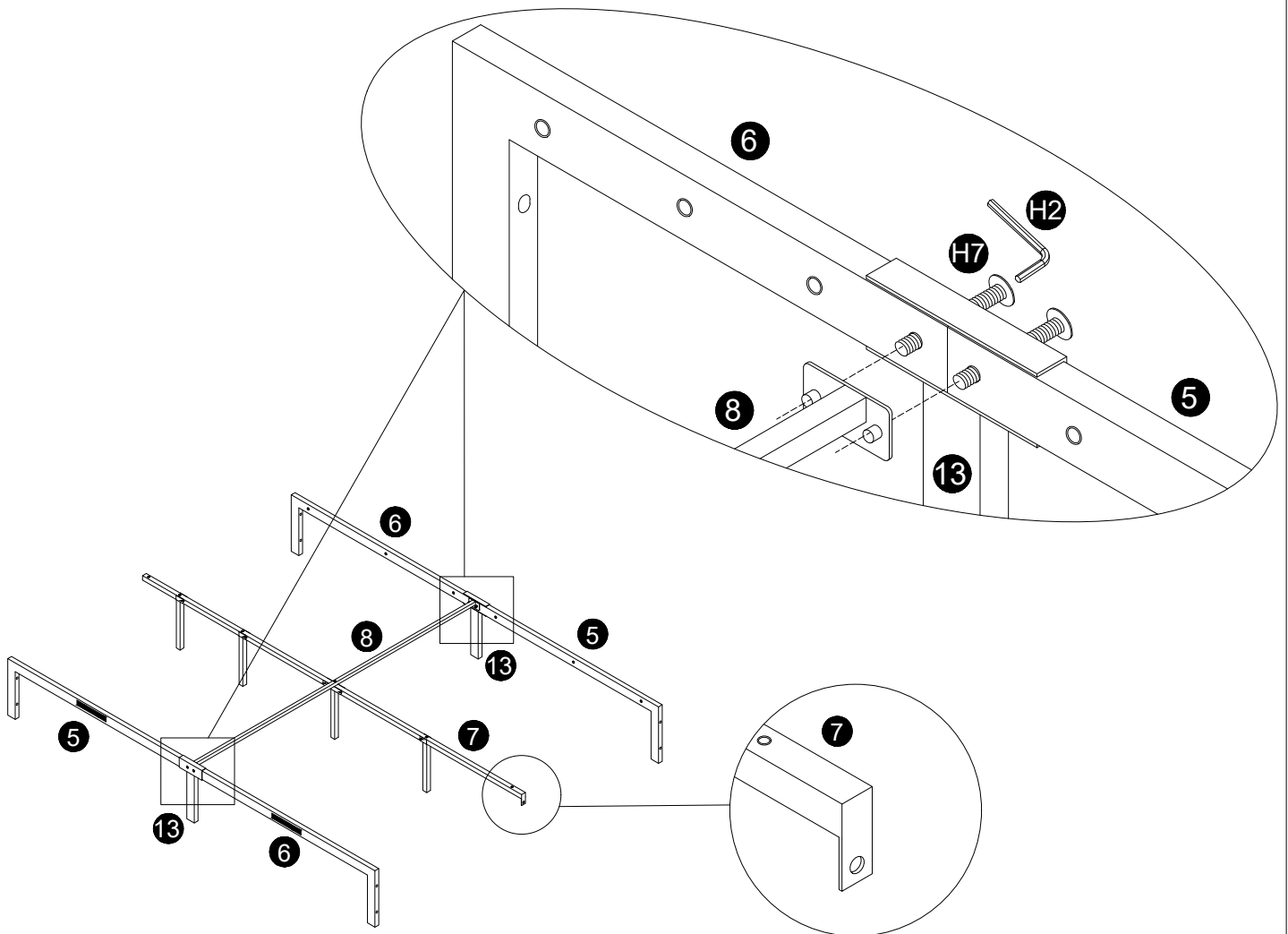

6

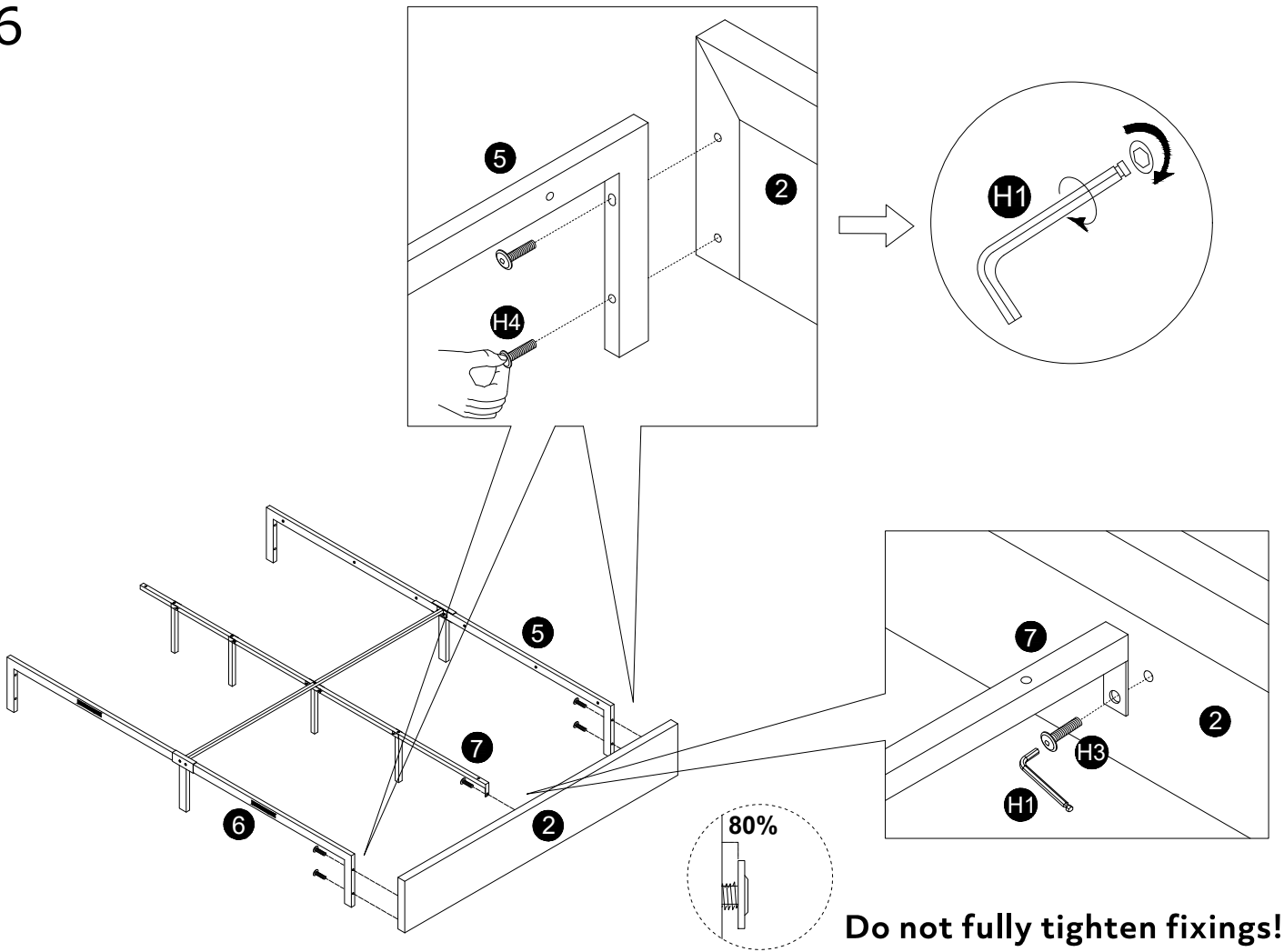

Do not fully tighten fixings!

7

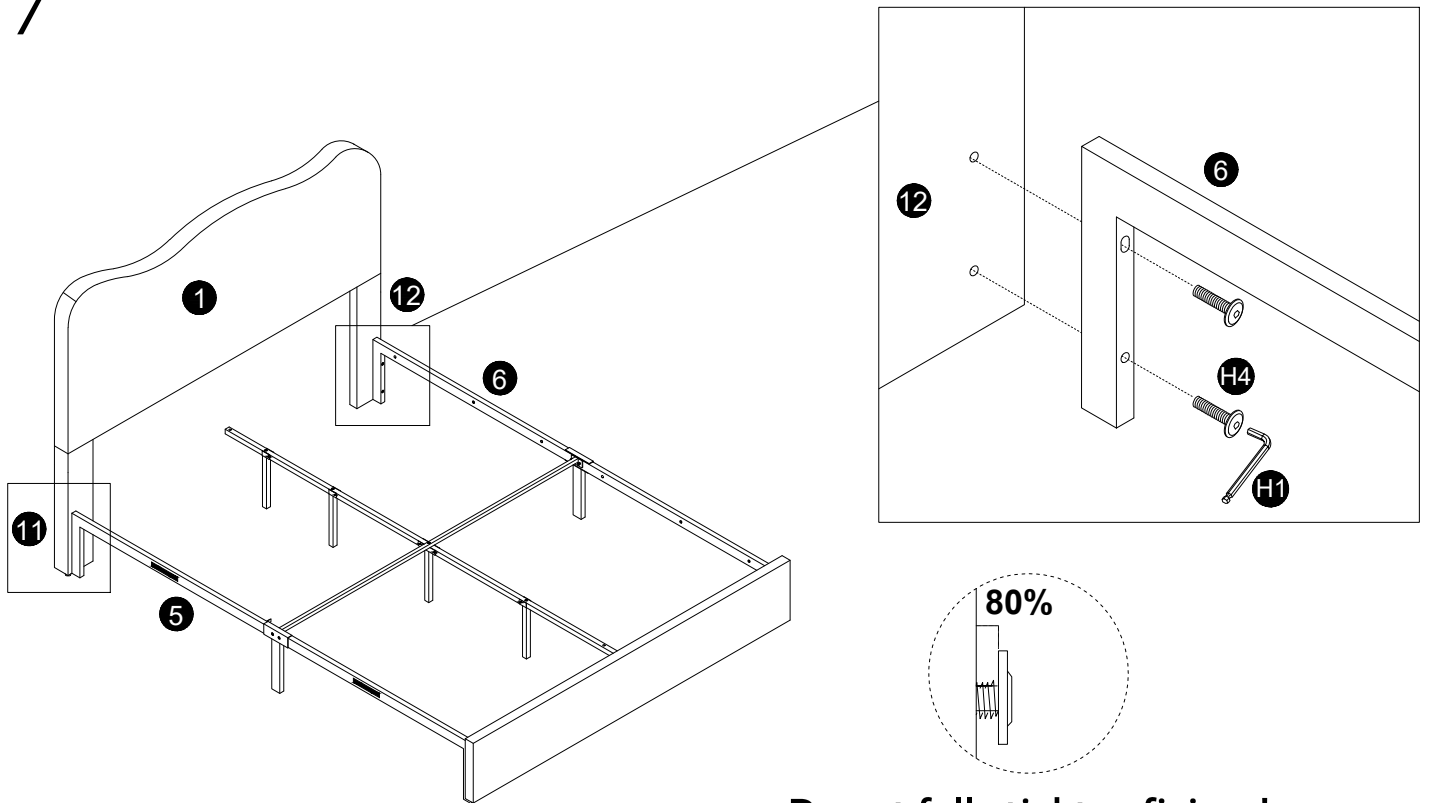

Do not fully tighten fixings!

8

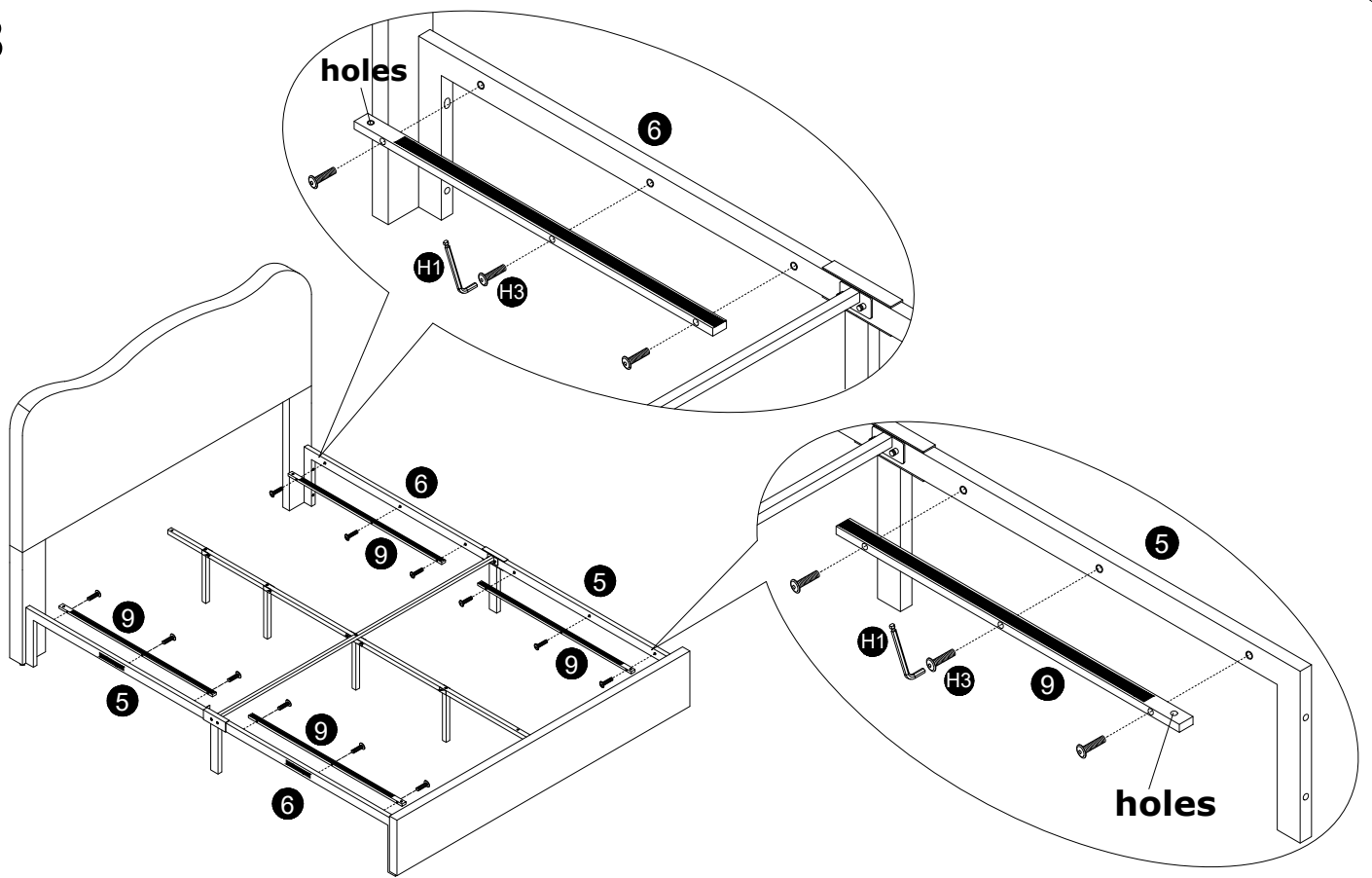

9

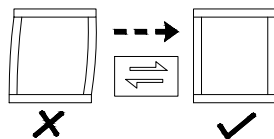
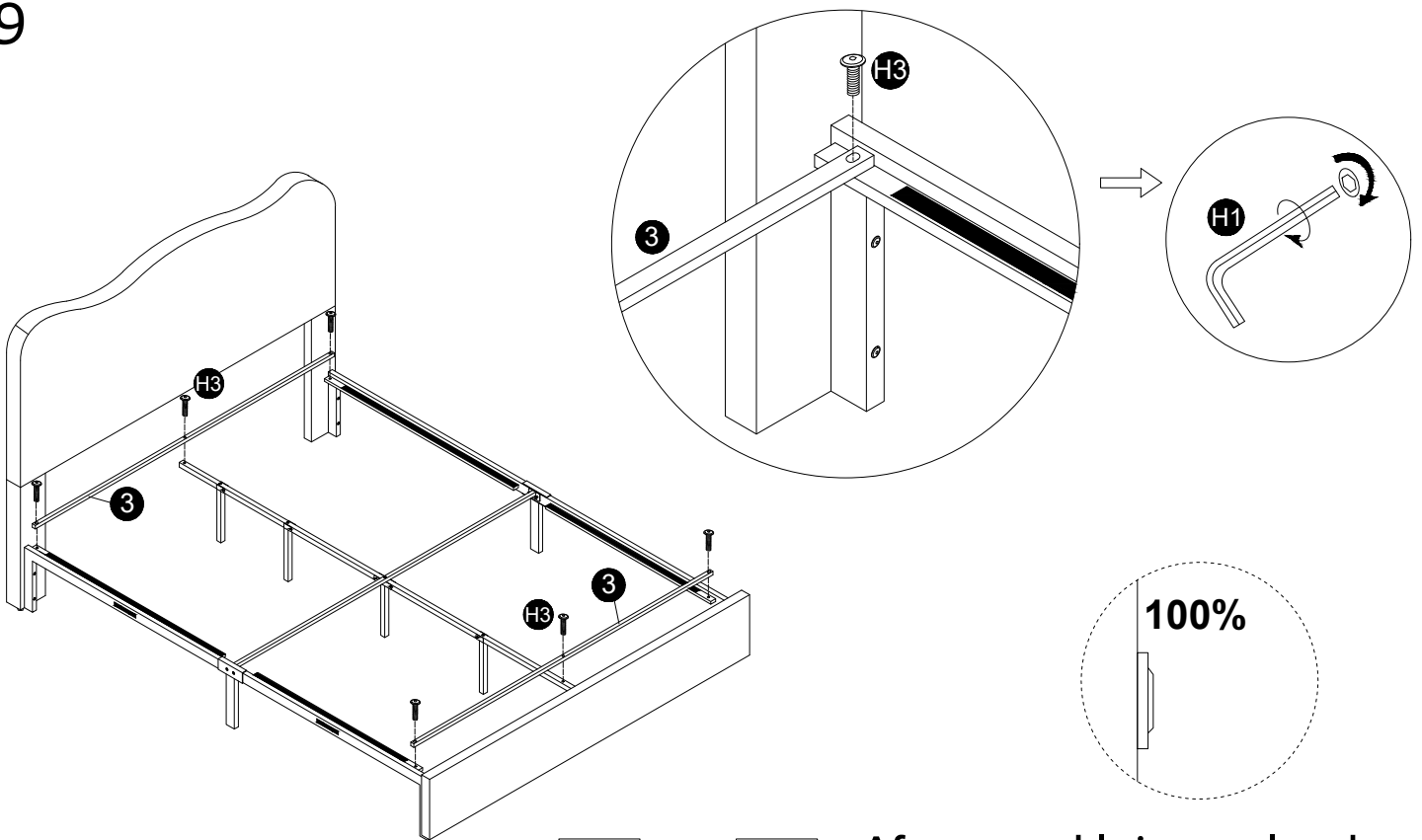

After assembly is completed,  
fully tighten step 6 and step 9  
all fixings.

10

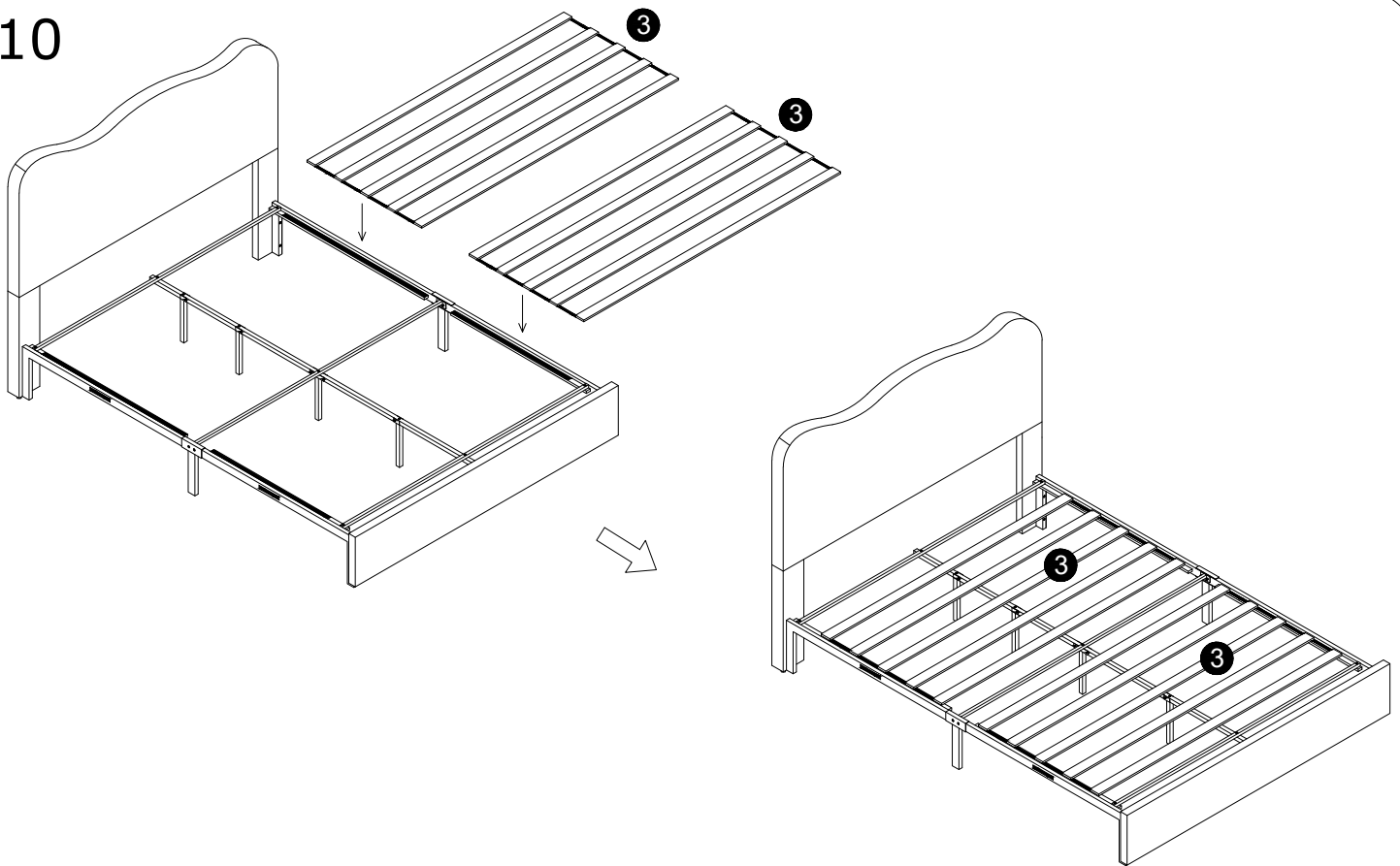

11

Put plastic baseboard (A) flat on the floor, assemble side baffles (C&D), following the assemble picture aligning them inward, ensuring all fit into all slots, and push forcefully until the side panels are flush with the baseboard.

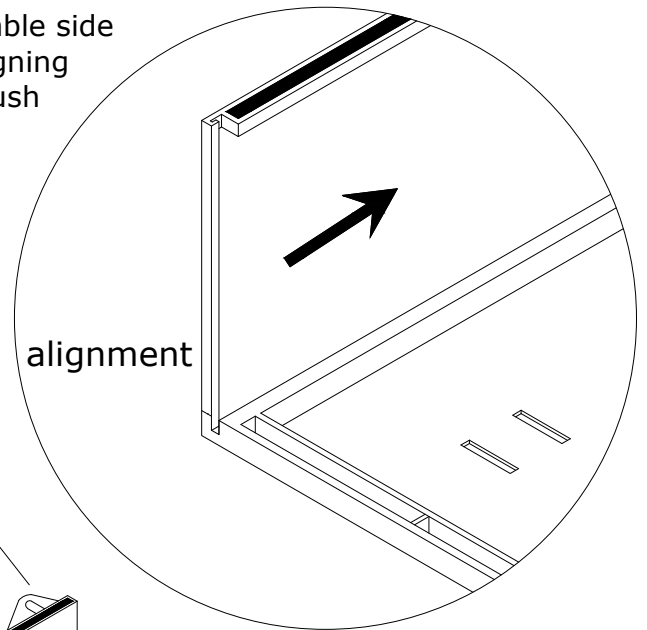
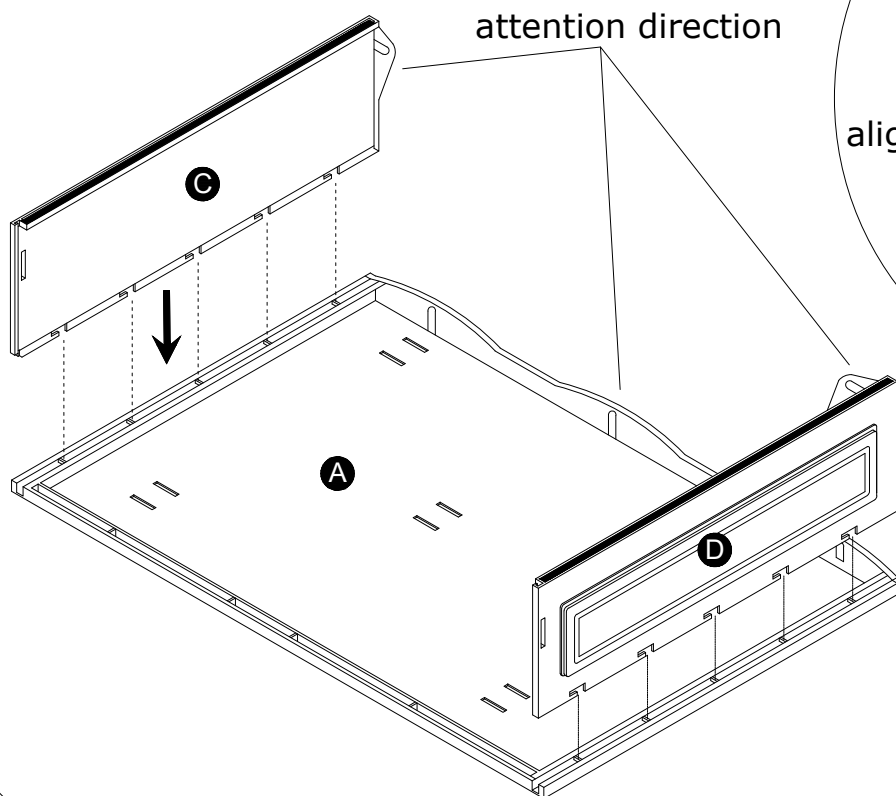



12

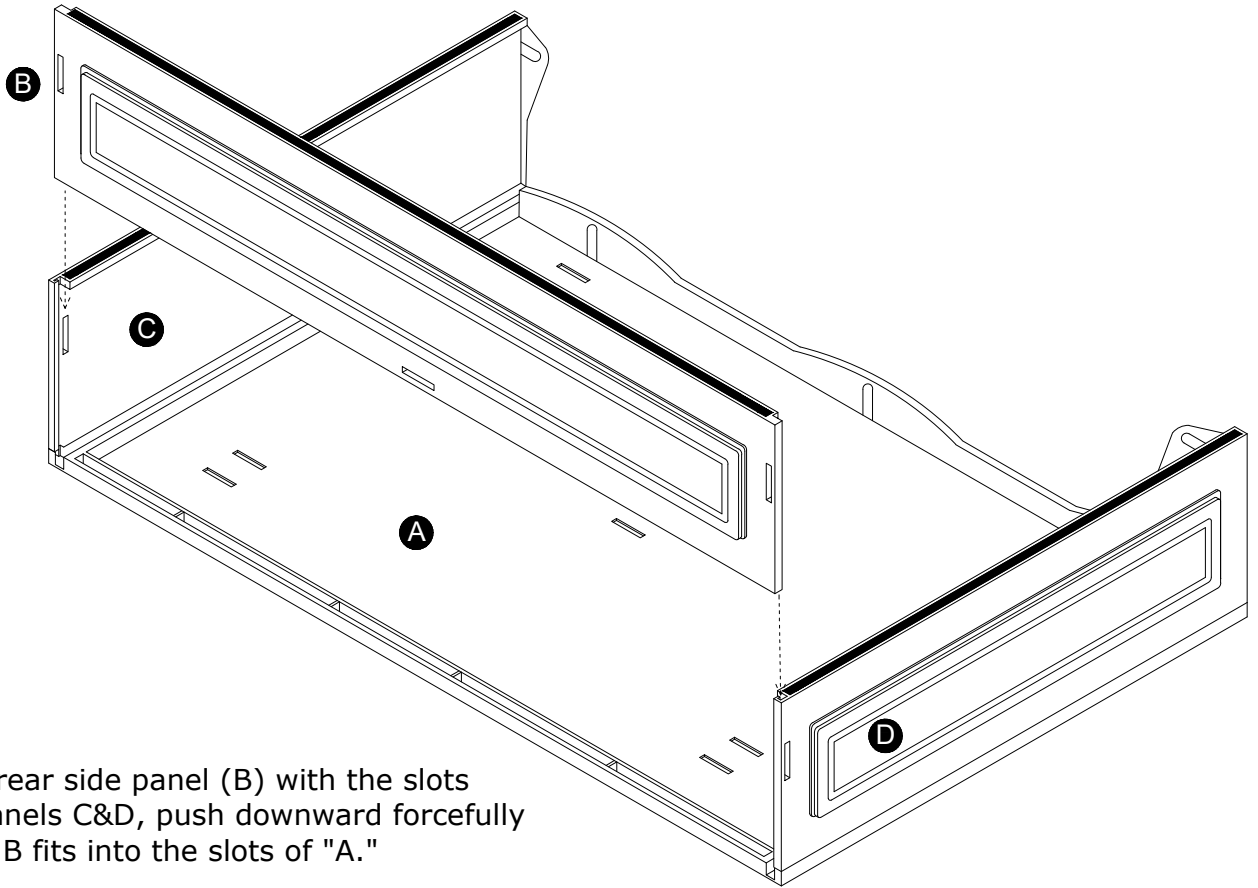

Align the rear side panel (B) with the slots on side panels C&D, push downward forcefully to ensure B fits into the slots of "A."

13

Take clip H14 and secure side panels D&B, B&C, and A&B, ensure the clips fully engage with the slots.

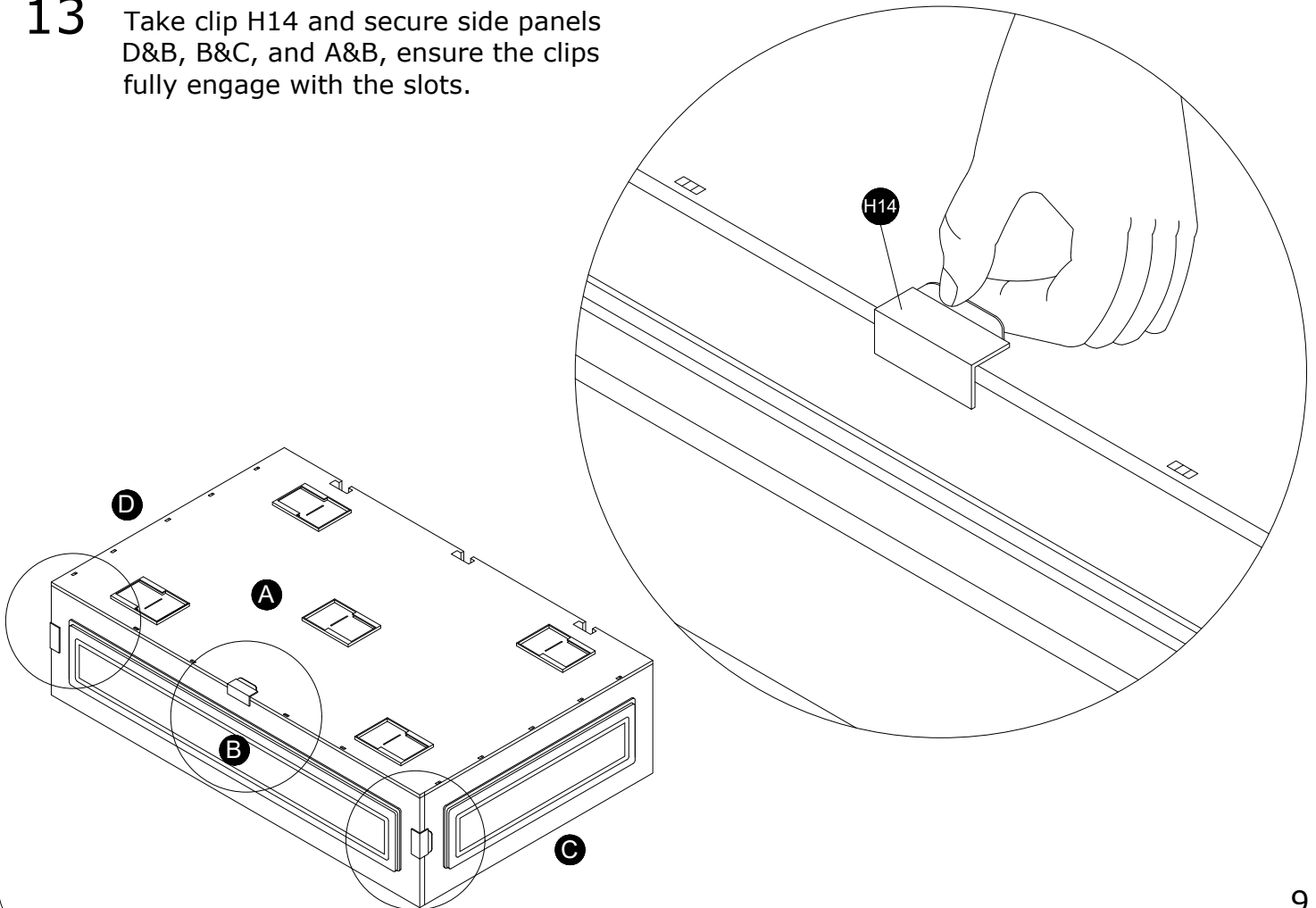

14

Install wheels "E" by forcefully pushing them into the slots; once pushed to the bottom, a protrusion will engage with the metal sheet to prevent them from easily coming off. All five part "E" wheels need to be installed correctly.

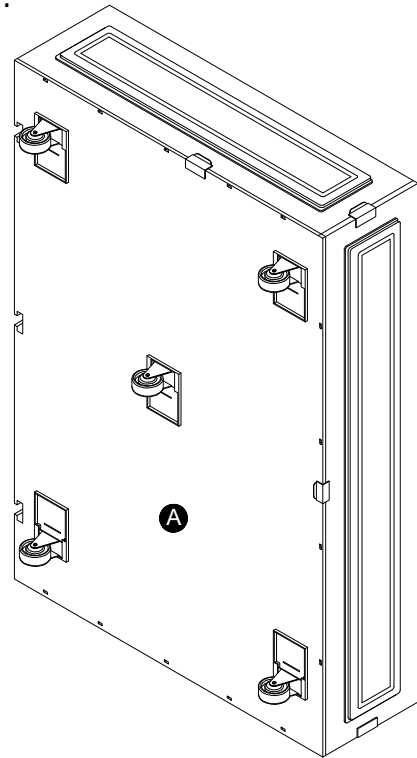
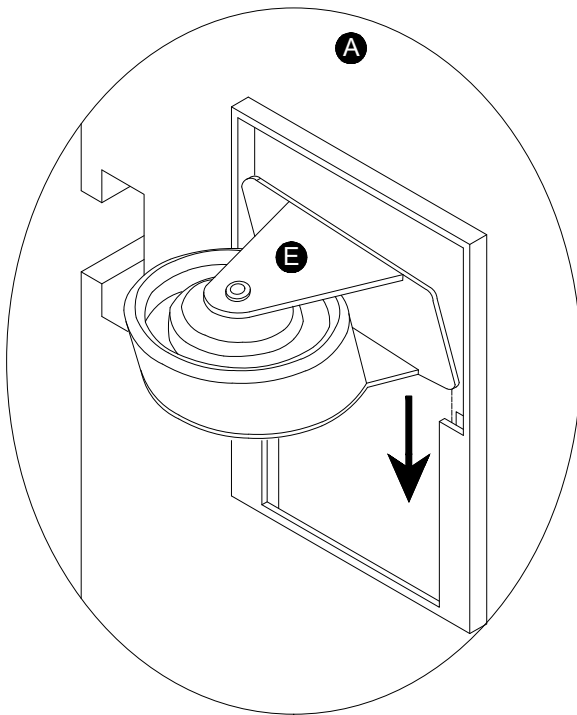

15

Take screw H9, first install it into drawer panel 14, then screw in the bottom 3 screws partially leaving them protruding 8mm (for easy installation). Insert the drawer bottom A into the three screws of the panel, ensuring no distortion of the drawer and panel to prevent plastic parts from breaking during installation.

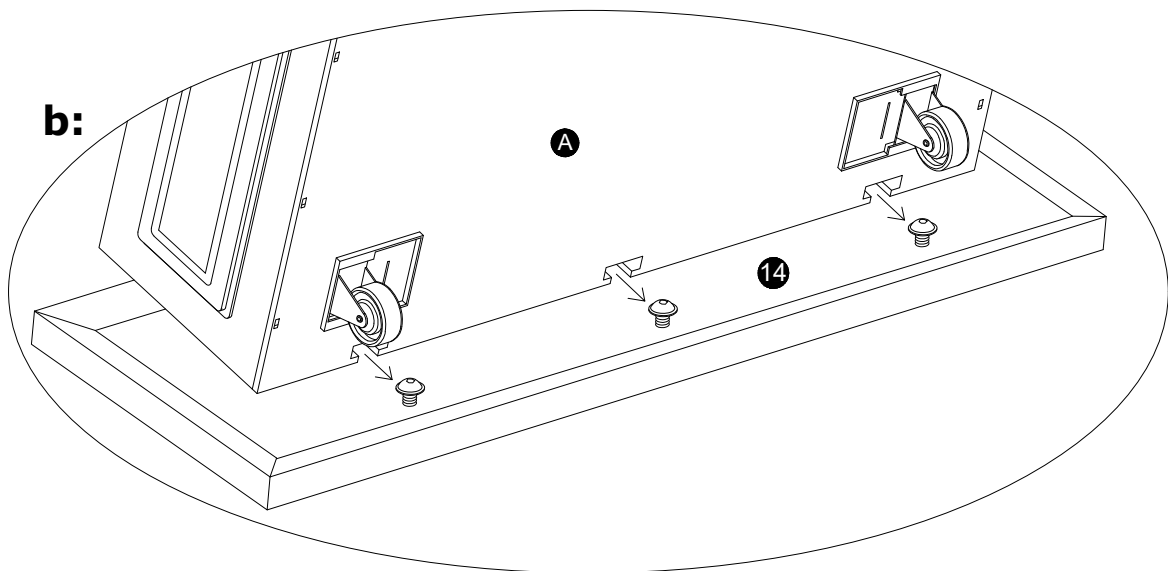
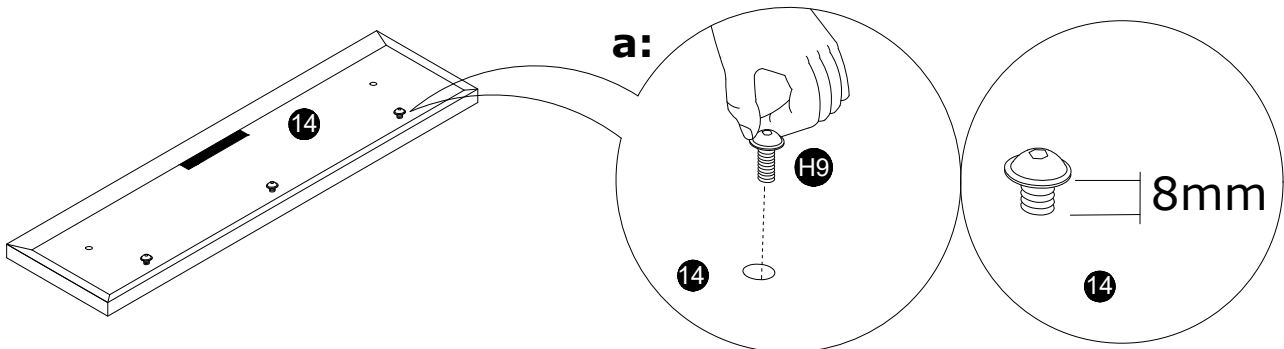

16

Put the drawer flat, install screw H9 through the holes in drawer sides C&D, then tighten all screws.

**Note:** Plastic drawers should not be installed with power tools; tightening manually is sufficient.

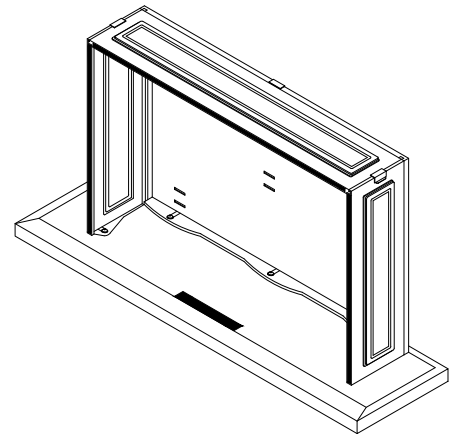
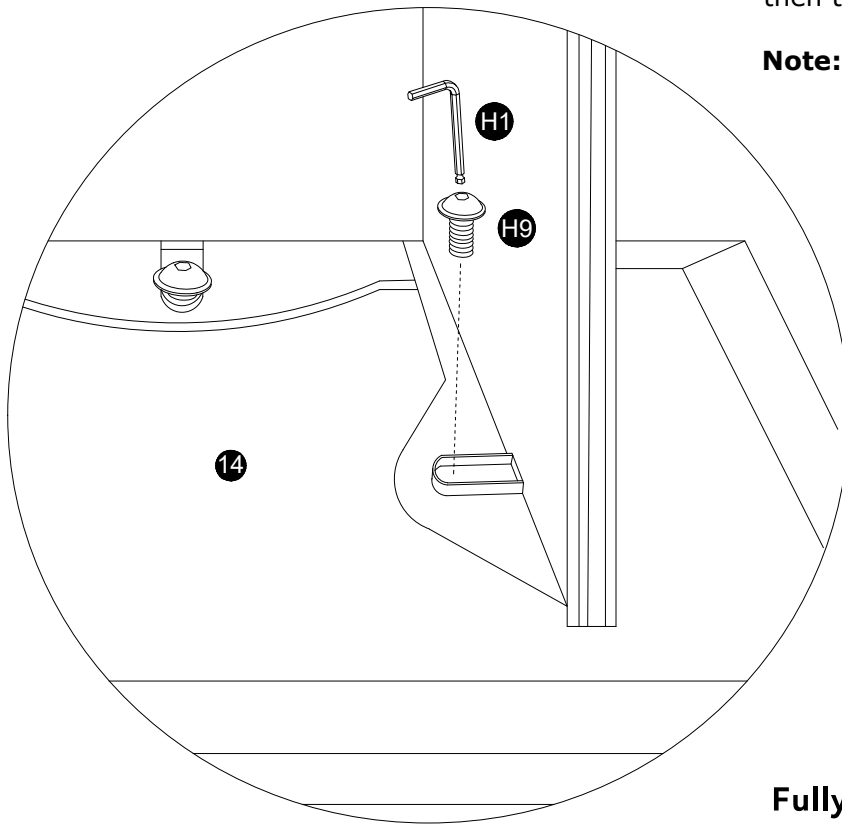

**Fully tighten all fixings.**

17

