

PAS-2520-SS

INSTRUCTION MANUAL



Hello! Please read these important attentions...

Please put a thick carpet on the ground to protect the furniture finish and corners. During the installation process, **DON' T** fasten screws tight 100% at a time.

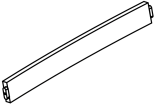
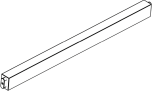
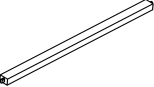
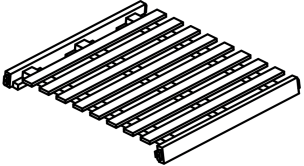
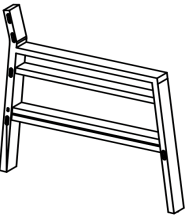
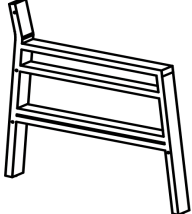
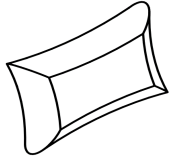
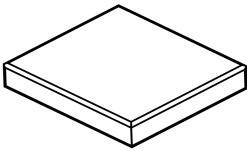
ASSEMBLY INSTRUCTION

NUMBER	COMPONENT	QUANTITY
A	 Upper Back Slat	2
B	 Middle Back Slat	1
C	 Lower Back Slat	1
D	 Seat Panel	1
E	 Right Leg Panel	1
F	 Left Leg Panel	1
G	 Back Cushion	1
H	 Seat Cushion	1

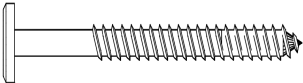
ASSEMBLY INSTRUCTION

NUMBER	COMPONENT	QUANTITY
①	 <p align="center">Screw (M6*90mm)</p>	9
②	 <p align="center">Allen Wrench</p>	2

Assembly Preparation :

Before Beginning Assembly:

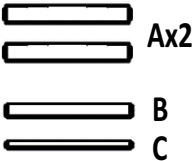
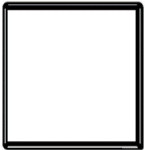
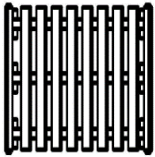
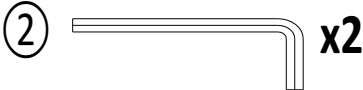
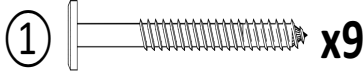
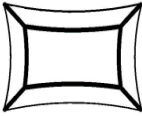
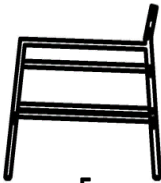
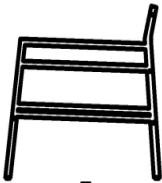

ASSEMBLY INSTRUCTION

Overview:

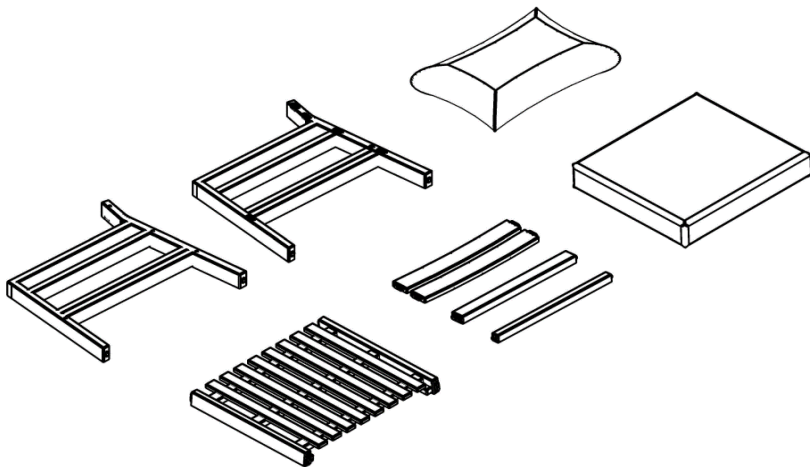
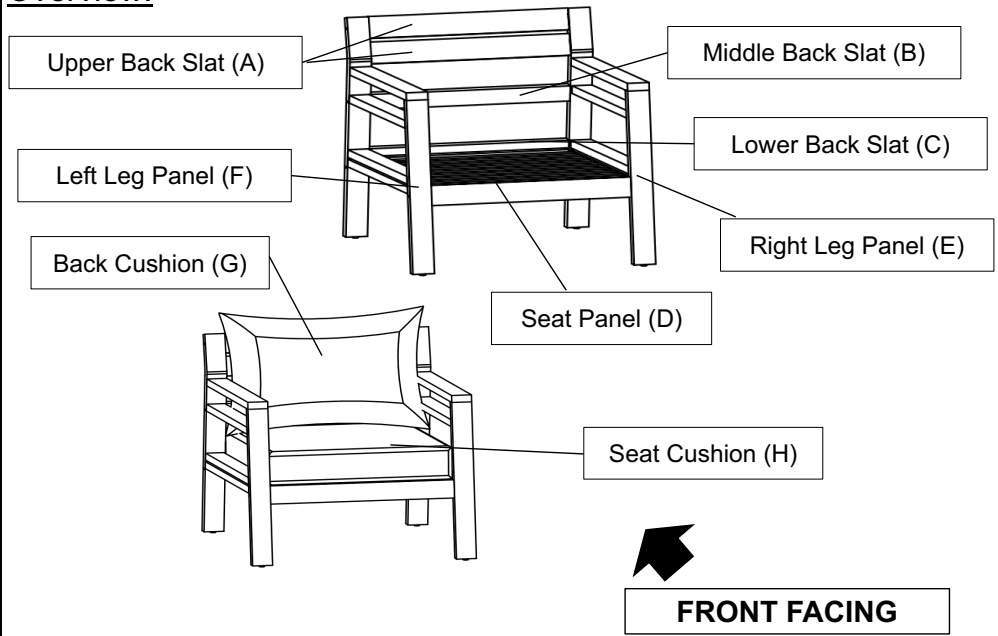

ASSEMBLY INSTRUCTION

①

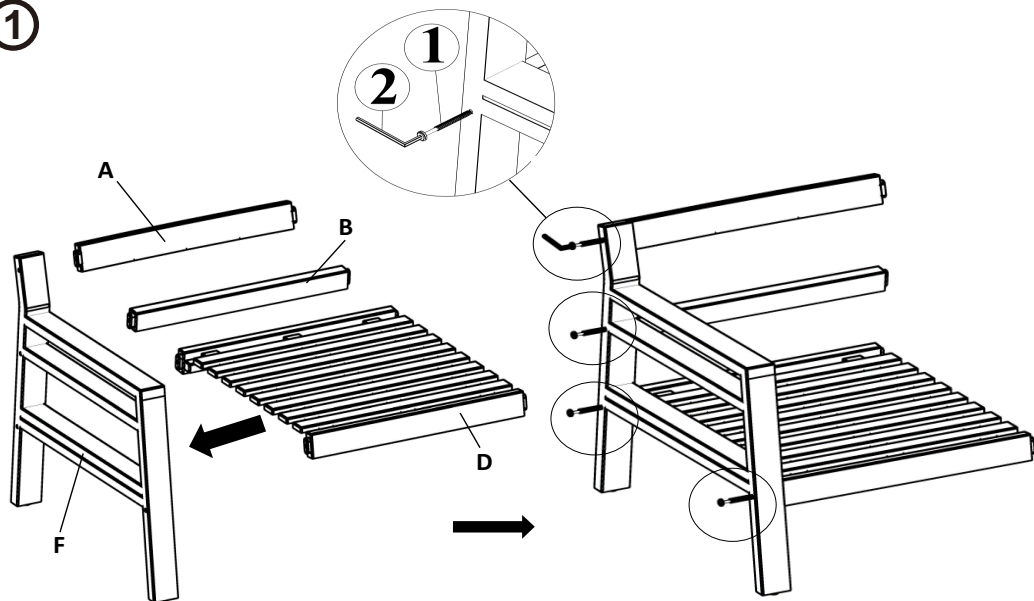

With the help of your adult partner, put the tenon of Upper Back Slat (A), Middle Back Slat (B) and Seat Panel (D) into the mortise of the Left Leg Panel (F) and then secure by using Screw (1) and Allen Wrench (2) as shown above.

Note : only eighteen 80%.

②

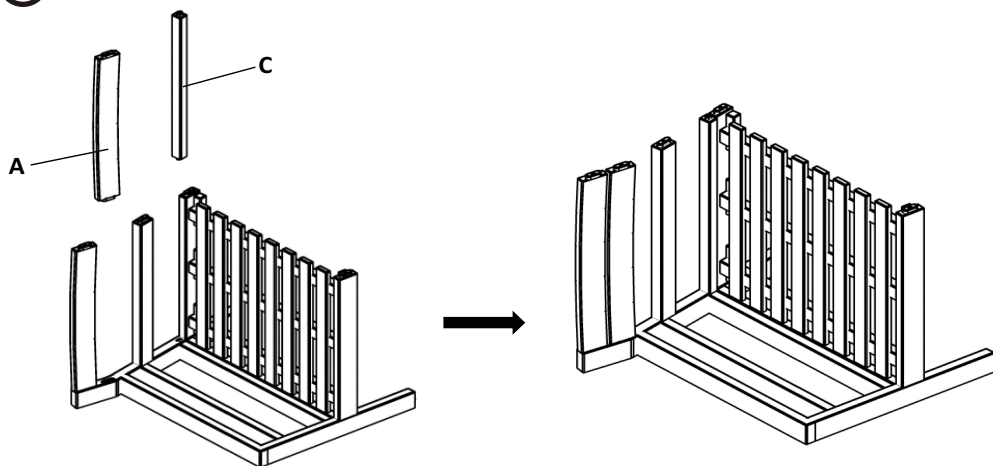

With the help of your adult partner, turn left side down the assembled part in Step 2 on a clean, non-marring surface.

Put the tenon of the remaining Upper Back Slat (A) and the Lower Back Slat (C) to the mortise of the Seat Panel (D) of the assembled part in Step 2 as shown above.

ASSEMBLY INSTRUCTION

③

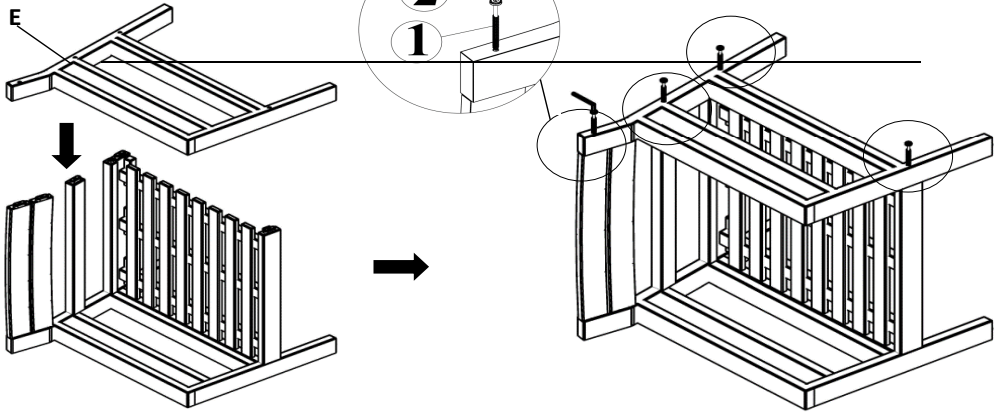

With the help of your adult partner, attach the Right Leg Panel (E) to the assembled part of Step 3 and then secure by using Screws (1) and Allen Wrench (2) as shown above.

④

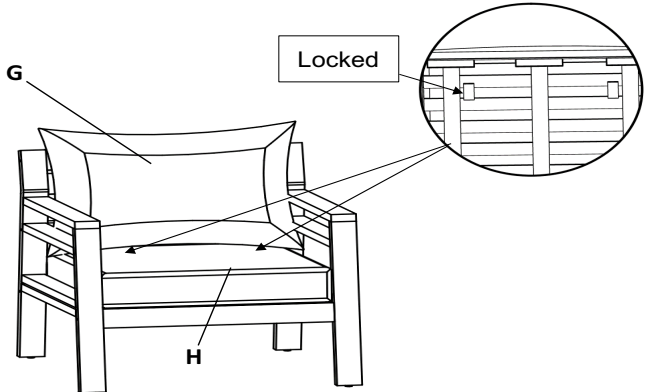
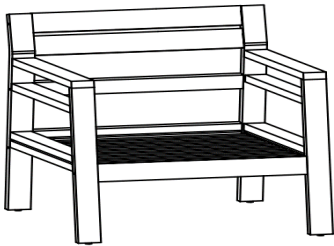



FORM FOR REPLACING MISSING OR DAMAGED PIECES.

Please email to : customerservice@directwicker.com

Model # of product : _____
Orderedby: _____
OrderedNo: _____
Deliverydate: _____

Were the boxes good when delivery to you Yes / No
Upon receiving the product,were all theparts intact Yes / No

Name : _____
Address : _____

Tel : _____

If the product is damaged after assembly, please provide photos of the entire furniture set and all damaged areas.

Part#	Qty	Description	Missing/Damaged
			M / D
			M / D
			M / D
			M / D

**If you do not receive a notification of the replacement parts within 1week,
please email us at customerservice@directwicker.com.**



Customer Instruction Card

To our most beloved and valued customer:

Thank you for your order, and we appreciate your trust and support.

If you need any assistance or have any questions about your order, please reach our customer service team with your order number at:

Direct Wicker Corp Tel:(813)-304-1389

ET: 9 AM - 5 PM, Monday- Friday

If you would like to know more about Direct Wicker or need to forward documents, you can also reach us at: **customerservice@directwicker.com**

Our team will always be here to help.

Common Questions:

1. Normally the cushion is placed within the ottoman/ chair, please turn it upside down, you may find the cushion.
2. Please do not fully tighten the screws before all parts were assembled successfully, in case the products can not be lined up in position.
3. Furniture sets are mostly delivered in multiple cartons. If the numbers of boxes you received are not correct/missing. Please contact us via phone or email with your order number.
4. Our cushions are considered as shower proof, and we recommend that when the furniture set is not in use, cover it with a furniture cover or store it in dry place.
5. Always be careful when cleaning or handling glass (Always wear gloves and read the instructions of any household cleaner.) We do not advise placing hot objects such as tea or coffee pots directly onto the surface of the glass, always use coasters.
6. If you would like to return the order, be sure to also return any accessories and packing slips that came with your original package.
7. For all your accessory needs, please visit our brand's official website: **directwicker.com**.
8. To preserve the longevity and beauty of your glass-topped wicker table, we recommend placing it in a shaded area away from direct sunlight. Additionally, please use a rain cover to protect it when not in use.

Thank you for your understanding and cooperation, we wish you a fantastic shopping experience with us, and we are looking forward to serving you again!

Direct Wicker Team

A stylized illustration of a hand holding a bouquet of flowers. The bouquet consists of several stems with small, light blue and pink flowers. The hand is shown from the bottom right, holding the stems.

Your Home Our Passion



For more information, please visit our website:

www.directwicker.com