

# Assembly Instructions



Caution: You must read this before you proceed

## Barstool



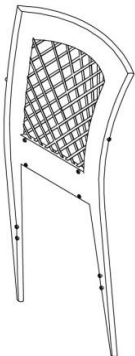



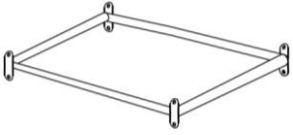
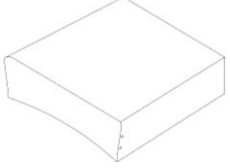

### Part List

Label	Picture	Description	QTY
A		Backrest (with Legs)	1

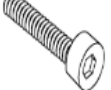
B		Right Armrest (with Leg)	1
C		Left Armrest (with Leg)	1
D		Foot Rest	1
E		Seat Panel	1

## Hardware

Label	Picture	Description	QTY
①		Bolt (M6*15mm)	9
②		Bolt (M6*35mm)	9
③		Bolt (M6*60mm)	3
④		Washer	19
⑤		Cap	19
⑥		Allen Key	1

## Assembly Preparation

Before Beginning Assembly:

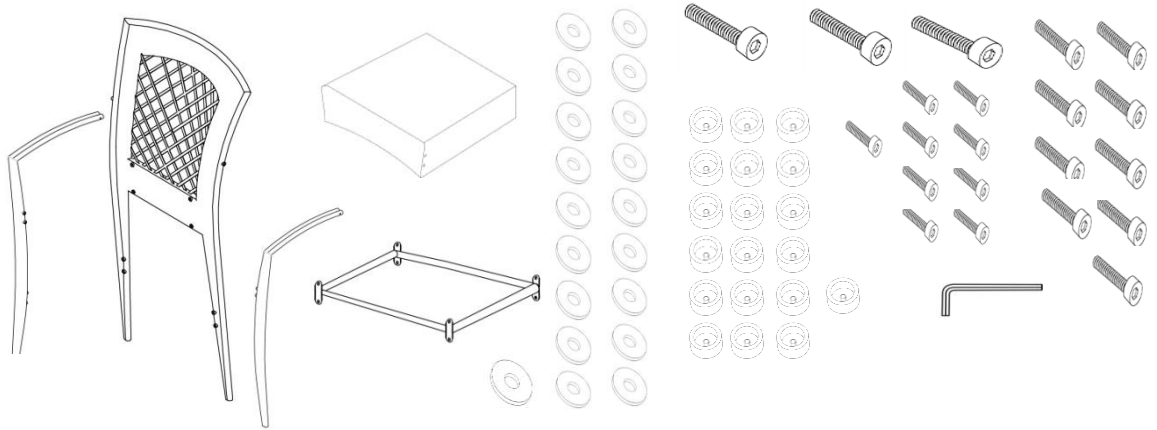

- Read instructions, cover to cover-



- Have 2 adults on hand for assembly-



- Do not assemble on flooring or carpet-



- Assemble on a clean non-marring surface (packing foam)-



- Save all packaging until finished-

## Assembly Steps

### Overview

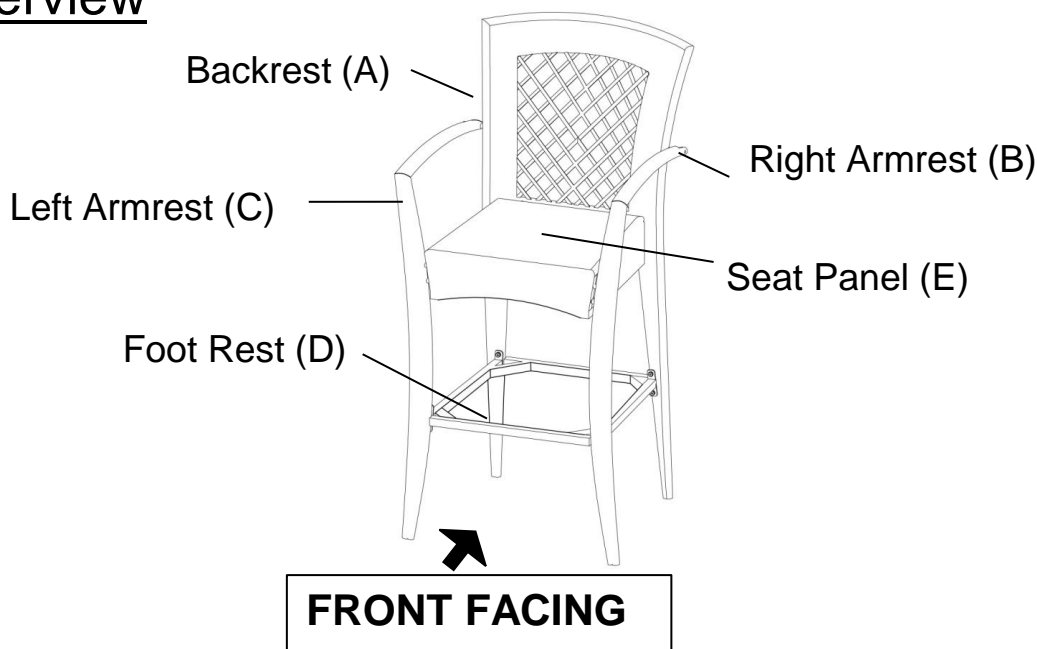

This Barstool has multiple parts and may require up to 30 minutes to assemble. To give you an overview of the Barstool parts, the above picture is to help you put the various parts into perspective. Please read through the instructions below to familiarise yourself with the parts and steps before assembly.

## Step 1

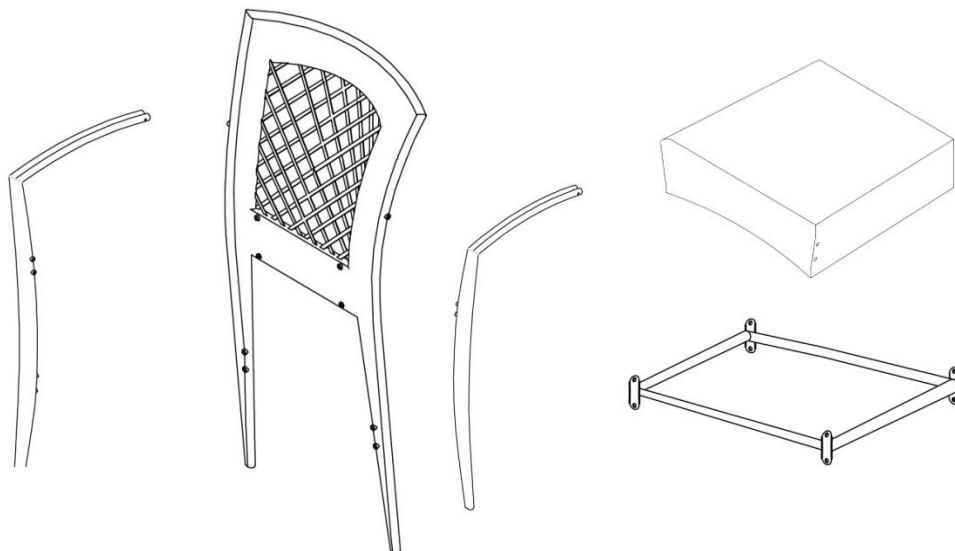

Unpack and place all parts on a clean, non-marring surface.

## Step 2

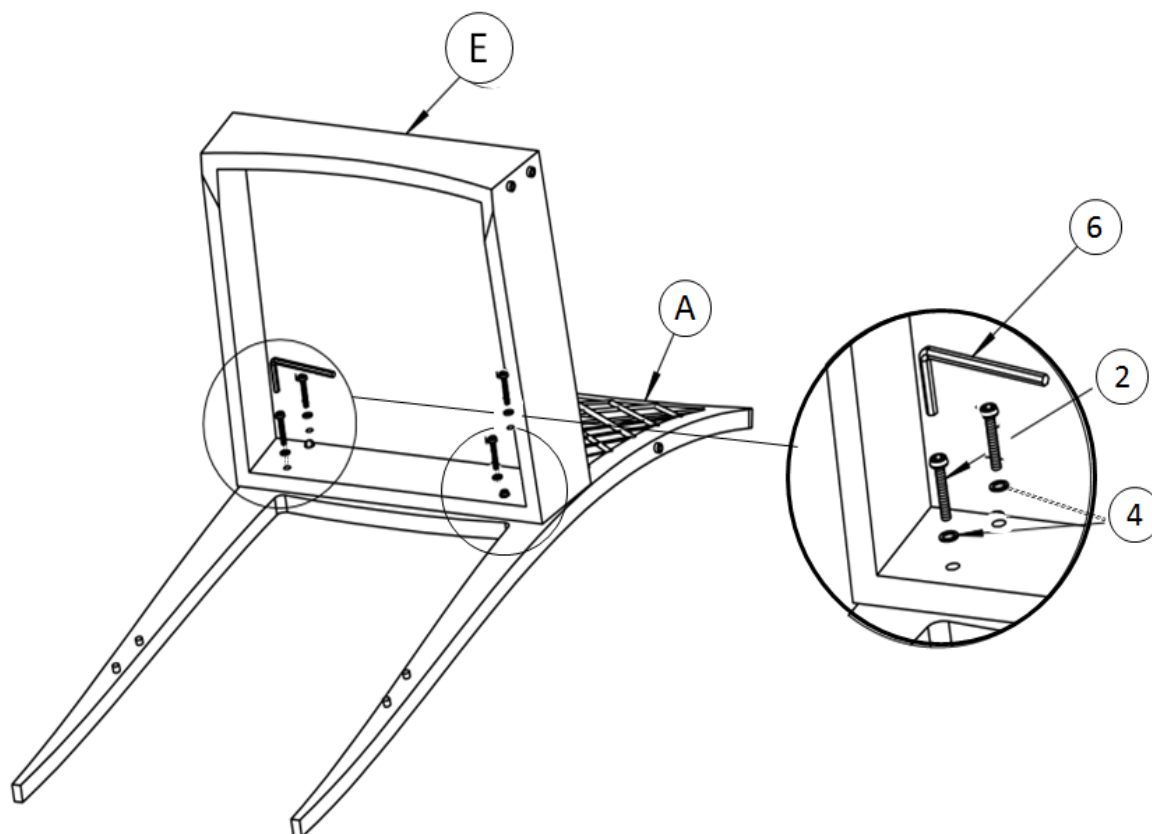

Place the Backrest(A) on the clean, non-marring surface.

Attach the Seat Panel(E) to Backrest(A) using Bolts(②) and Washers(④) with Allen Key(⑥).

**Do not fully tighten the Bolts.**

### Step 3

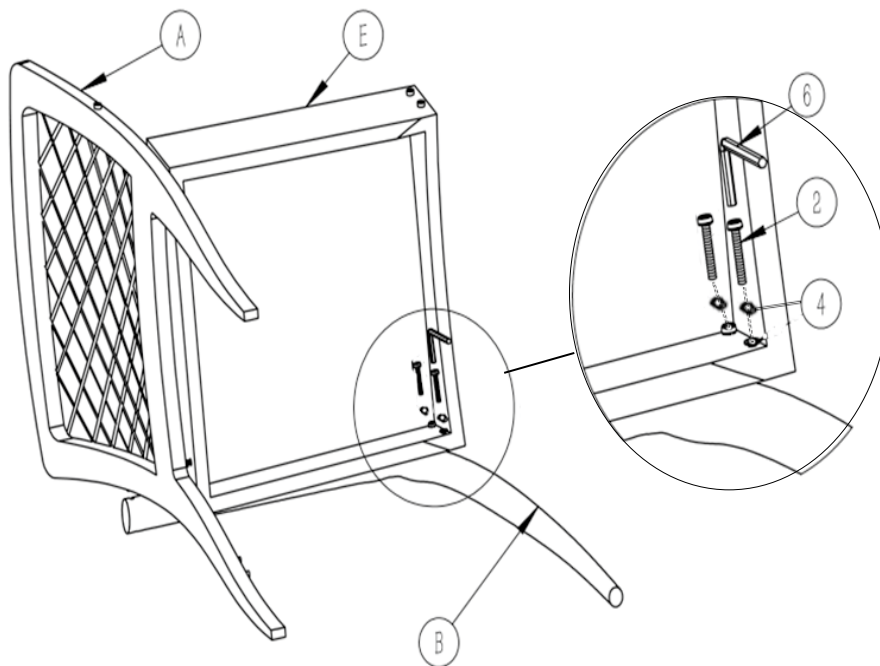

Place the Right Armrest(B) on the clean, non-marring surface.  
Attach Seat Panel(E) to Right Armrest(B) using Bolts(②) and Washers(④) with Allen Key(⑥).  
**Do not fully tighten the Bolts.**

### Step 4

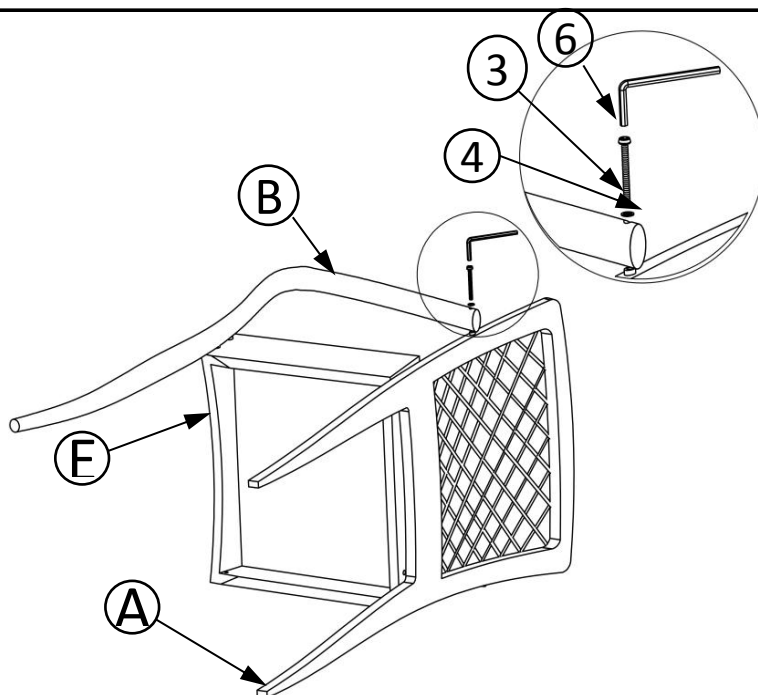

Place the Seat Panel(E) and the Backrest(A) on the clean, non-marring surface.  
Attach Right Armrest(B) to the Backrest(A) using Bolts(③) and Washers(④) with Allen Key(⑥).  
**Do not fully tighten the Bolts.**

## Step 5

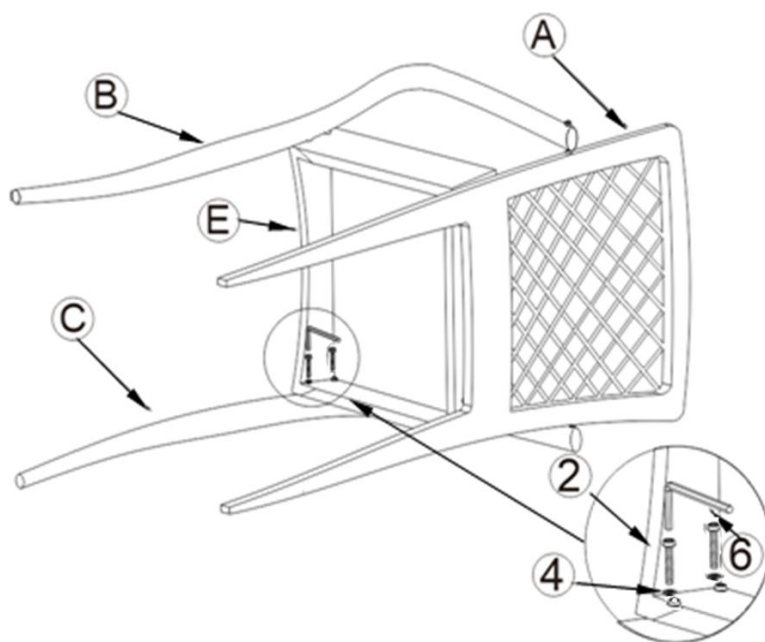

Place the Left Armrest(C) on the clean, non-marring surface.  
Attach Left Armrest(C) to the Seat Panel(E) using Bolts(2) and Washers(4) with Allen Key(6).  
**Do not fully tighten the Bolts.**

## Step 6

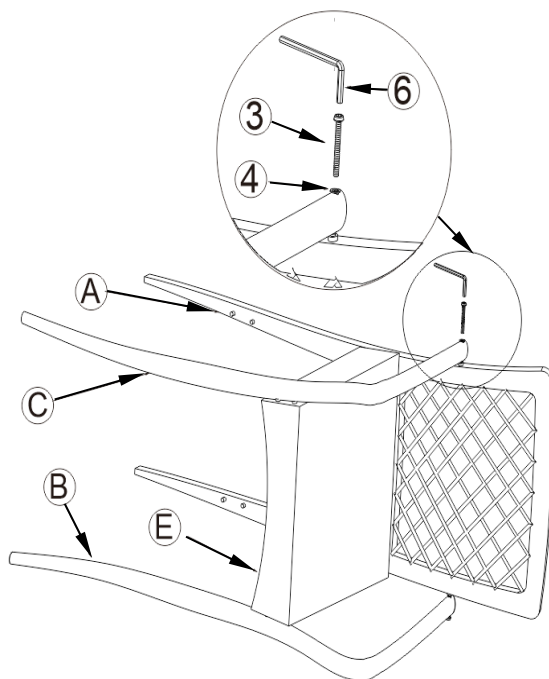

Place the Right Armrest(B) on the clean, non-marring surface.  
Attach Left Armrest(C) to the Backrest(A) using Bolts(3) and Washers(4) with Allen Key(6).  
**Do not fully tighten the Bolts.**

## Step 7

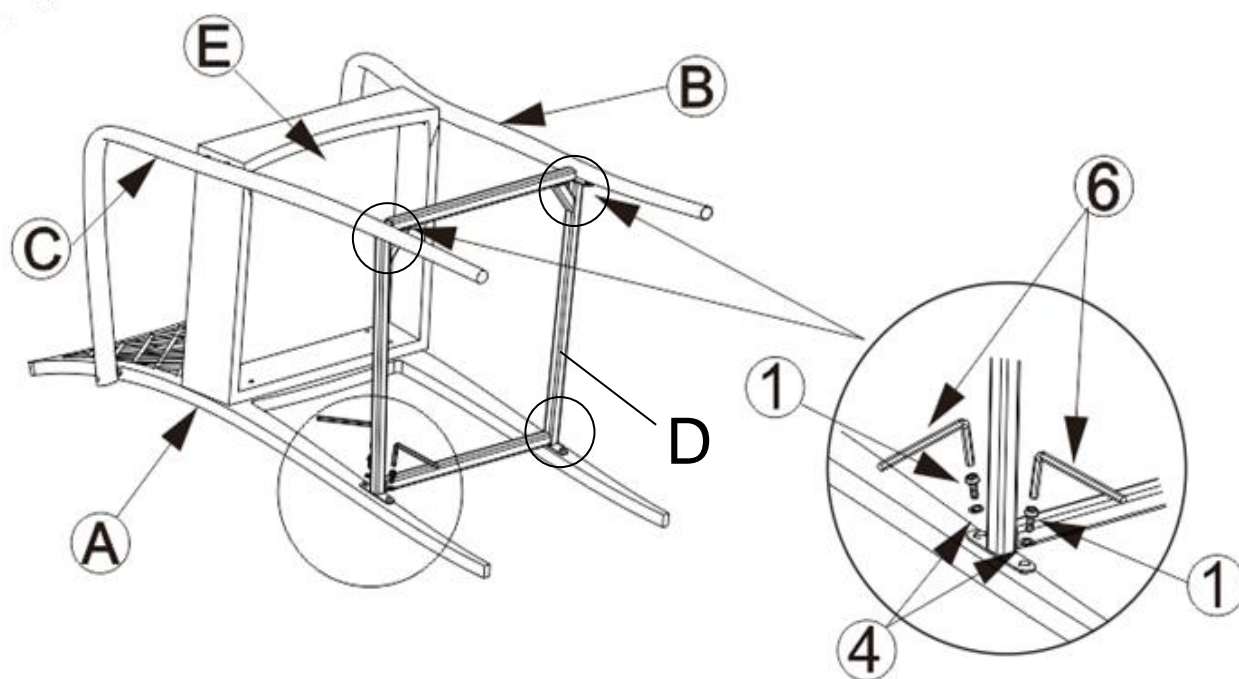

Place the Backrest(A) on the clean, non-marring surface.  
Attach Foot Rest(D) to the Backrest(A) using Bolts(①) and Washers(④) with Allen Key(⑥).

**Do not fully tighten the Bolts.**

## Step 8

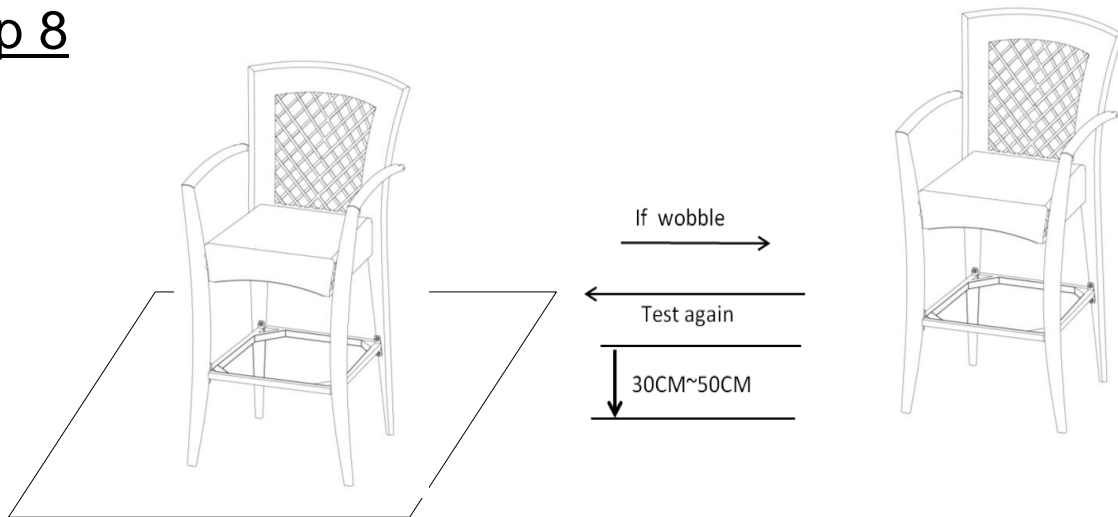

Place the Barstool on a **LEVEL SURFACE** to see if it wobbles.

If it wobbles, lift the Barstool some 30cm to 50cm high from the ground.

Keep your feet and toes well away from the drop zone.

Drop the Barstool freely and vertically with the four legs, hitting the ground, at the same time.

This Drop Test will help to ensure that all the Bolts and gaps all reach full alignment status.

Test again for evenness on a **LEVEL SURFACE**.

If no wobbles are found, proceed to tighten all the Bolts.

**When tightening the Bolts, tighten sequentially.**

**DO NOT tighten any Bolt fully and then move on to the next one.**

**This may cause the frame to warp.**

**If there are still wobbles, loosen the Bolts and execute the same drop test.**

## Step 9

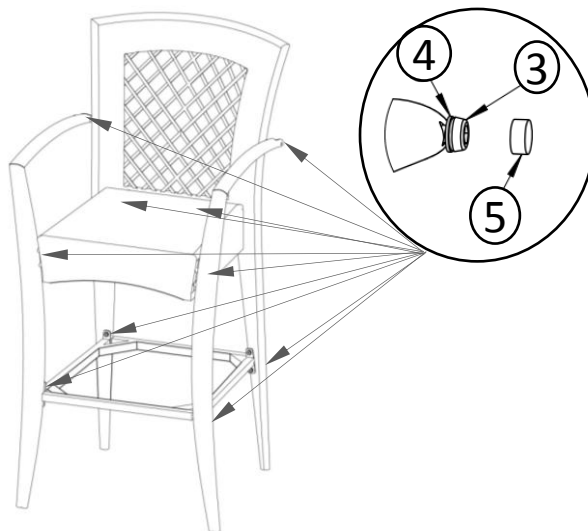

Cover the Bolts with Caps(⑤) by hand.

















## Step 10



Your Barstool is ready for use.

**This Barstool can only be used on a flat, level surface.**

### Care & Maintenance

-   ● Do not put hot items directly on furniture surface
-   ● Do not clean furniture with harsh cleansers or polish.
-  ● To obtain the longest lifespan of your outdoor products, minimizing exposure to direct sunlight is recommended.
-   ● Children should not climb or jump on the furniture.
-   ● Do not write on furniture without a padded barrier to protect the surface.
-  ● To obtain the longest lifespan of your outdoor products, avoid extended and lengthy exposure to rain, snow, and direct sunshine. Whenever possible cover the product and /or place under patio or awnings.
-   ● Not for commercial use. For residential use only .
-   ● Stains may be removed with mild soap solution and damp cloth.
-  ● Keep away from sources of ignition.
-  ● Dust and pick-up spills using a clean, non-colored, lint-free cloth.