

Assembly Instructions

Caution: You must read this before you proceed

Please look in the First Leg Panel for hardware packs.

Table

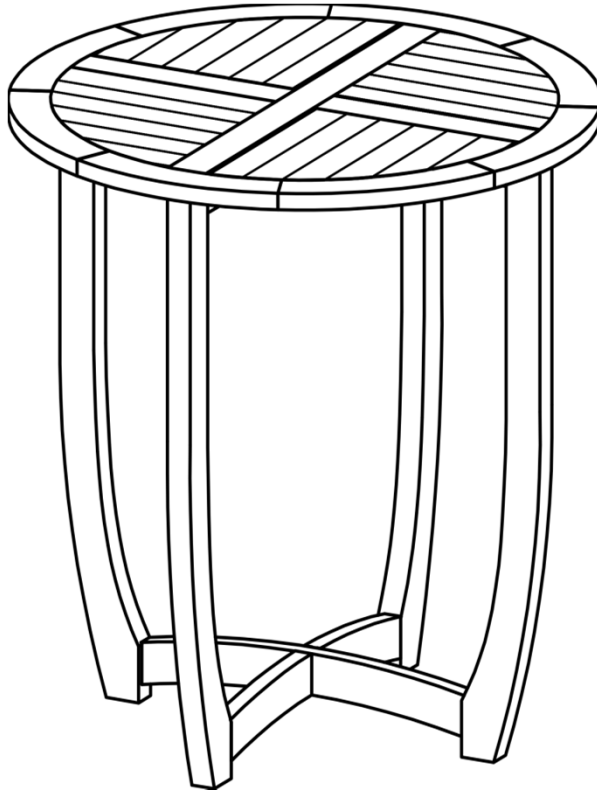



Caution: This Table is NOT a TOY

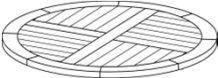

Keep your child/ children at bay during the assembly process.

For moving the Table and to prevent damage to the Table, two adults may be needed to execute these actions.

Parts List

Label	Picture	Description	QTY
A		Table Top	1
B		First Leg Panel (Labelled B)	1
C		Second Leg Panel (Labelled C)	1

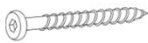
Hardware

Label	Picture	Description	QTY
①		Screws (M6x45mm)	9
②		Allen Key	1

Assembly Preparation

Before Beginning Assembly:

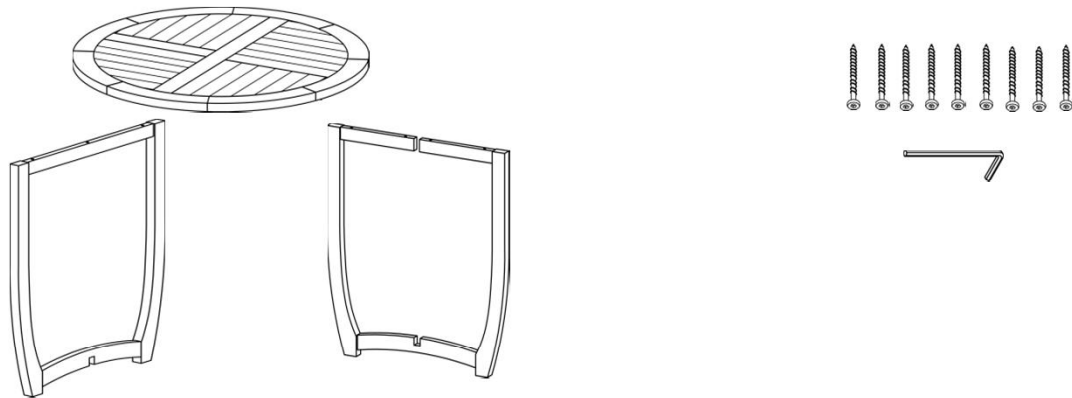

- Read instructions, cover to cover-



- Have 2 adults on hand for assembly-



- Do not assemble on flooring or carpet-



- Assemble on a clean non-marring surface (packing foam)-



- Save all packaging until finished-

Assembly Steps

Overview

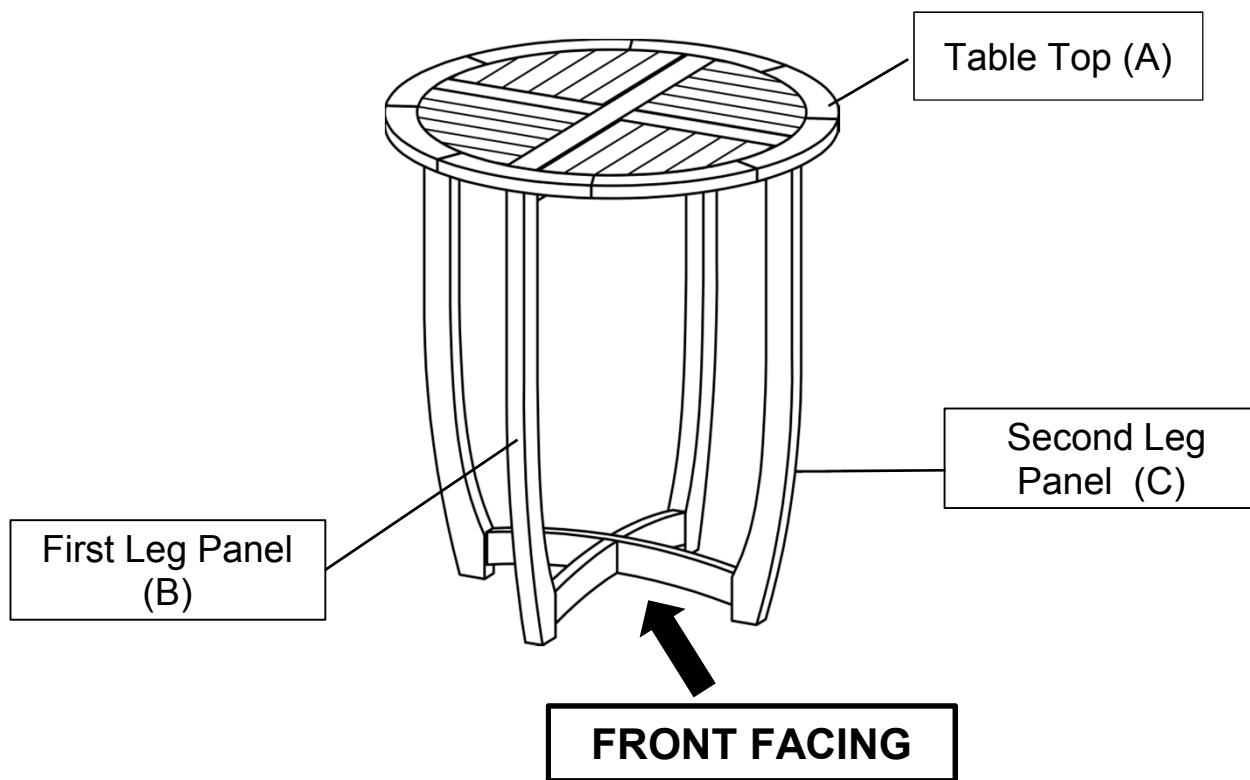

This Table has multiple parts and may require up to 30 minutes to assemble. To give you an overview of the Table parts, the above picture is to help you put the various parts into perspective. Please read through the instructions below to familiarise yourself with the parts and steps before assembly.

Step 1

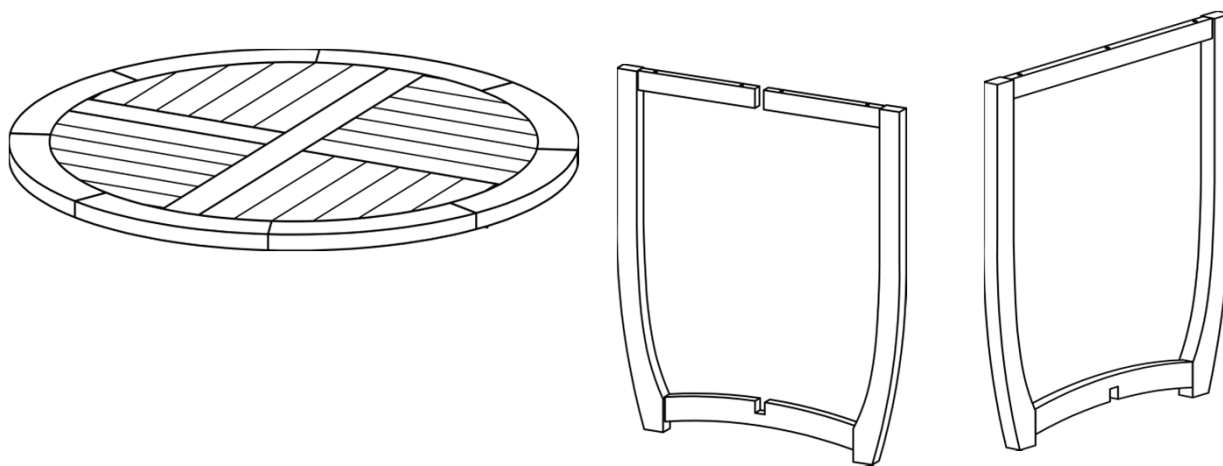

Unpack and place all parts on a clean non -marring surface.

Step 2

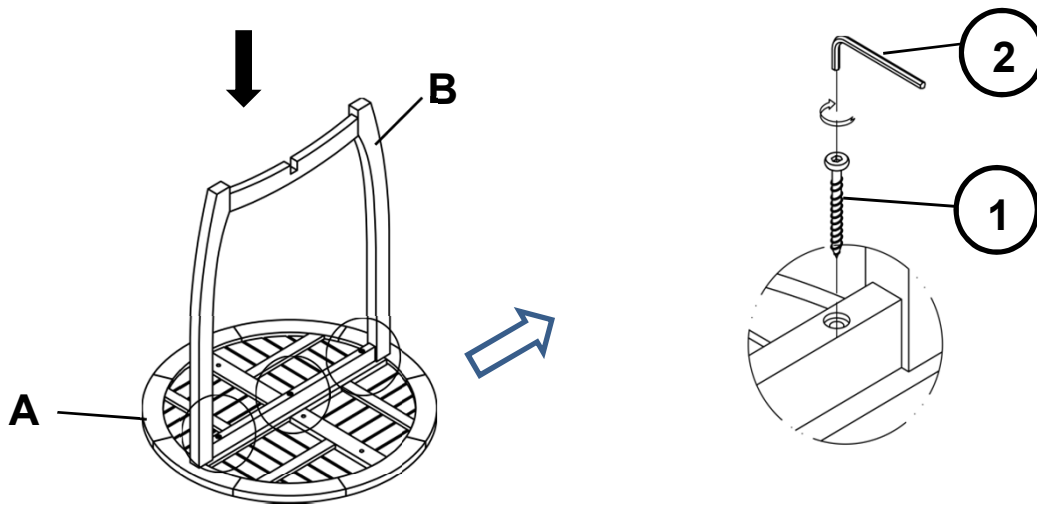

Place the Table Top (A) facedown on a clean, non-marring surface.
Position the First Leg Panel (B) on to the Table Top(A).
Insert three Screw (①),through the mounting positions of the First Leg Panel (B) and affix using the Allen Key(②)
Only loosely tighten the Screws.

Step 3

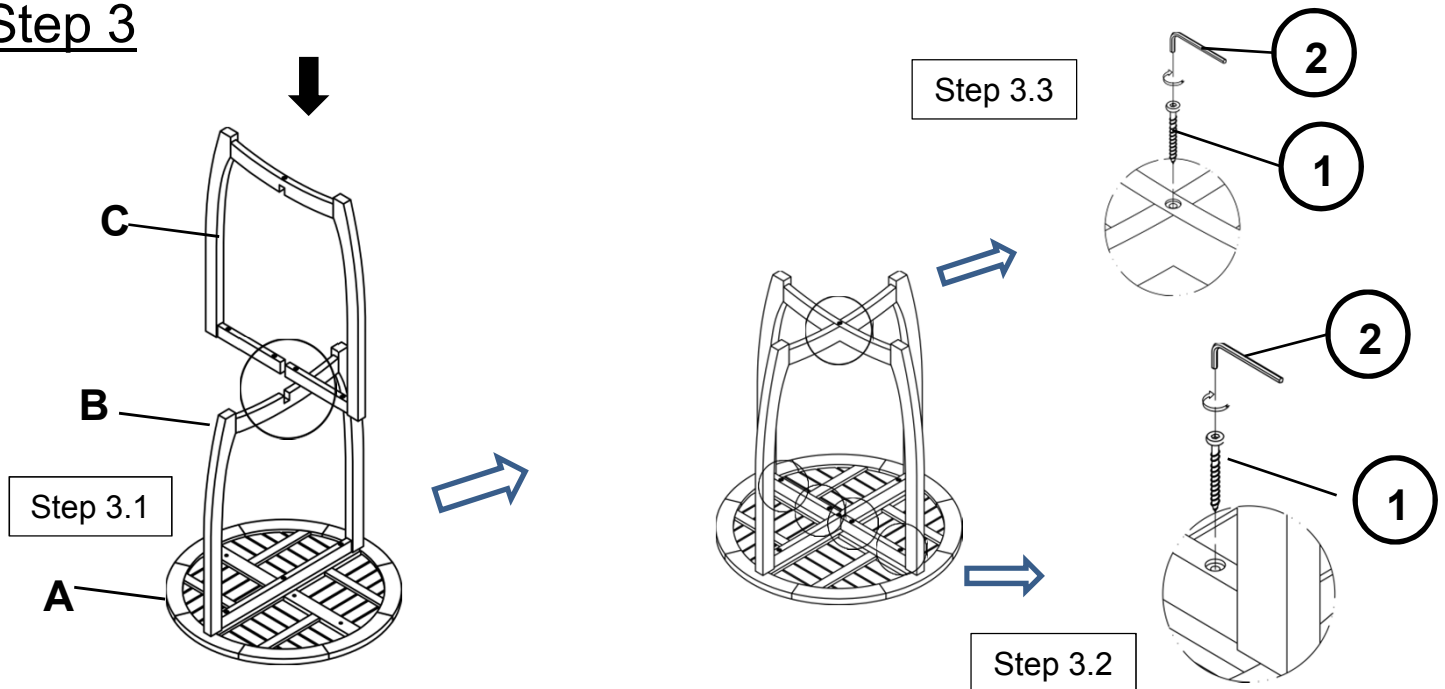

3.1)Position separated point of the Second Leg Panel (C) over the First Leg Panel (B) on to the Table Top(A).

3.2) Insert four Screws (①)through the mounting positions of the Second Leg Panel (C) into the Table Top(A) and affix using the Allen Key(②)

3.3) Affix First Leg Panel (B) and Second Leg Panel (C) using Screw (①) with Allen Key(②)

Only loosely tighten the Screws.

Step 4

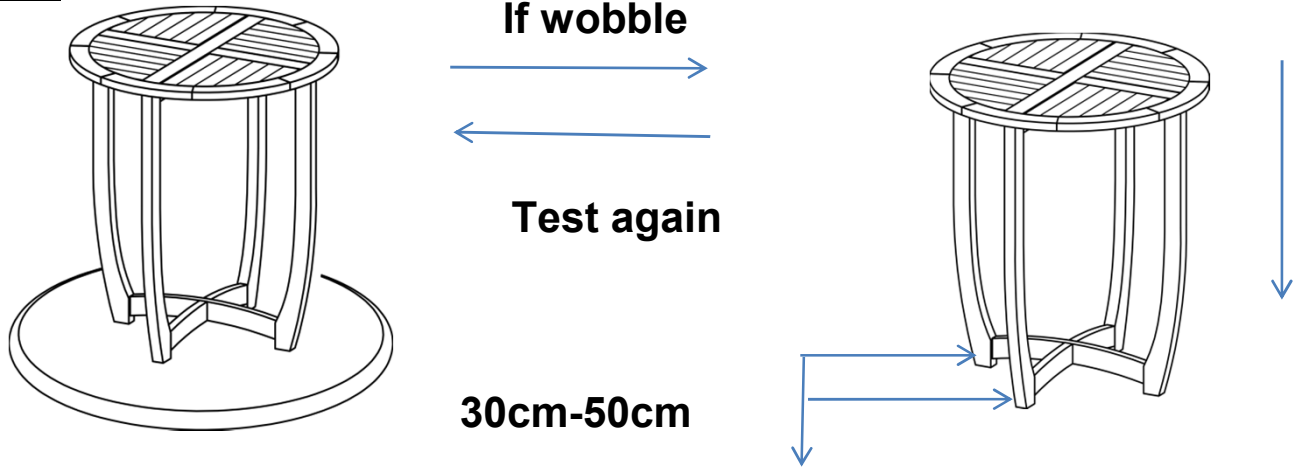

Place the Table right side up on a LEVEL SURFACE to see if it wobbles. If it wobbles, lift the Table to some 30cm to 50cm height from the ground. Keep your feet and tose weell away from the drop zone. Drop the Table freely and vertically with the four legs, hitting the ground, at the same time. This Drop Test will help to ensure that all the Screws and gaps all reach full alignment status.

Test again for evenness on a LEVEL SURFACE .

If no wobbles are found, proceed to tighten all Screw.

CAUTION: When tightening the Screw tighten sequential. DO NOT tighten any Screw fully and then move towards the next one. This could cause the frame to warp.

If there are still wobbles ,loosen the Screws and execute this same drop test.

If the Table is not stable, it could lead to damage to the product.

Step 5

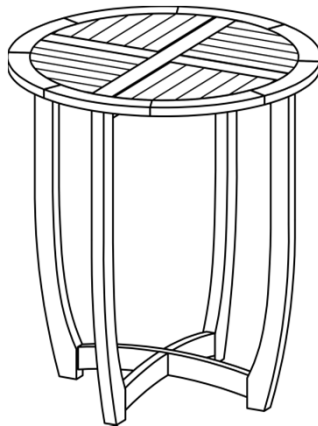









Inspect Table and make sure all parts are adequately connected.

Your Table is ready for use

This Table can only be use on a flat, level surface.

Care & Maintenance

-  ● Do not put hot items directly on furniture surface
 -  ● Do not clean furniture with harsh cleansers or polish.
 -  ● To obtain the longest lifespan of your outdoor products, minimizing exposure to direct sunlight is recommended.
 -  ● Children should not climb or jump on the furniture.
 -  ● Do not write on furniture without a padded barrier to protect the surface.
 -  ● To obtain the longest lifespan of your outdoor products, avoid extended and lengthy exposure to rain, snow, and direct sunshine. Whenever possible cover the product and /or place under patio or awnings.
 -  ● Not for commercial use. For residential use only .
 -  ● Stains may be removed with mild soap solution and damp cloth.
-
-  ● Dust and pick-up spills using a clean, non-colored, lint-free cloth .