

Storage Shed Owner Manual & Assemble Guide

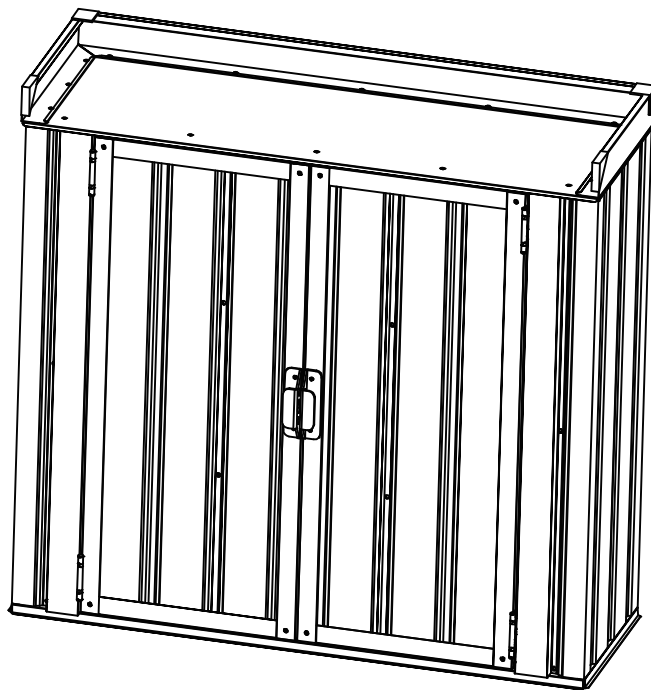

Customer Service:



If you have any problem, please contact us through the online platform.

Shed Size

Shed Overall Size:L167.7*W46.16*H72.83

All parts are packed in two boxes, please note that refer to the parts list to check if all parts are received.

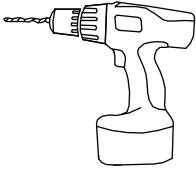
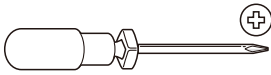
Please prepare below tools before installation. (Not Included)

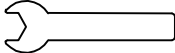
 Electric Screwdriver	 + Manual Screwdriver	 Ladder
Package included Tools	 Gloves x 1Pair	 Spanner x 1

ATTENTION

Care **MUST** be taken when handling various pieces of your building since many contain sharp edges.

Do NOT attempt to assemble your building before double checking that you have all parts indicated in the parts lists. Any building left partially assembled may be seriously damaged by even light winds.

Do NOT attempt to assemble your building on a windy day, the large panels can catch the wind like a “sail”, making construction difficult and unsafe. **Watch the weather closely.** Keep children and pets away from the worksite during construction and until the building is completely assembled. This will help avoid distractions and any accidents which may occur. Never concentrate your weight on the roof of the building.

Before assembling any parts, your base should be constructed and an anchoring system should be ready to use. Your building must be anchored to prevent wind damage.

ASSEMBLY

The best location is a level area with good drainage.

Allow enough space outside the building to be able to access the roof with a ladder.

USE TEAMWORK: Two or more people are required to assemble your building.

CARE & MAINTENANCE

Do NOT use power washing to clean your shed.



















Combustibles and corrosives must be stored in air tight containers designed for chemical and/or combustible storage.



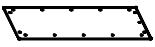















Rust Protection Precautions

Avoid nicking or scraping the coating surface, inside and out.

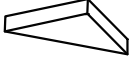
PLEASE KEEP THIS INSTRUCTION FOR FUTURE REFERENCE.

Part List

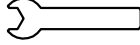
PART	NO.	QTY.
	C13W3-C	4
	C13W3-B	2
	C13-W3	2
	C13W3-K	2
	C13W2-HLR	2
	C13-1	2
	C13-2	2
	C13-3	2
	C13-4	2
	C13-5	2
	C13-6	2
	C13-7	4
	C13-8	2
	C13-9	1
	C13-10	1
	C13-11	1
	C13-12	1
	C13-13	2
	C13-14	1
	T19	1

PART	NO.	QTY.
	C13-DDA	4
	C13-UA	2
	C13-DA	2
	C13-DLA	1
	C13-DRA	1
	C13-DBA	4
	GB	2
	GC	2
	T-F	4
	C2	4
	C15	4
	DJ	4
	CT	8
	GD	2
	F1	154
	F2	21
	V2	16
	F8	8
	M4	1
	ST	2

NOTE: This is **not the beginning** of the installation steps; it is merely to indicate where each component will be installed.

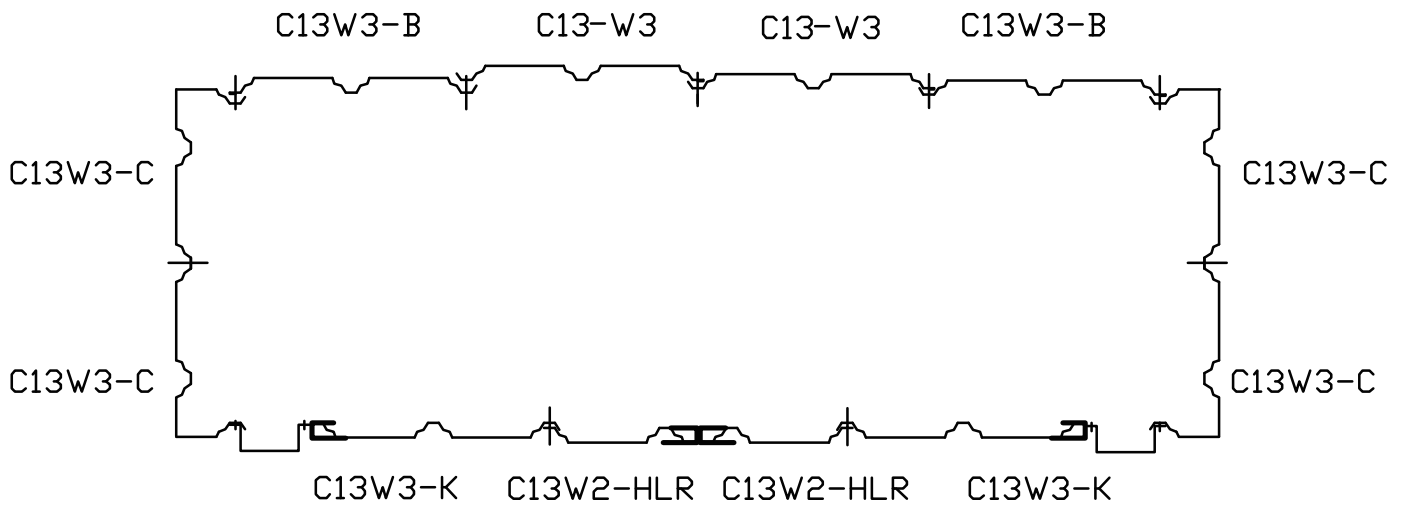



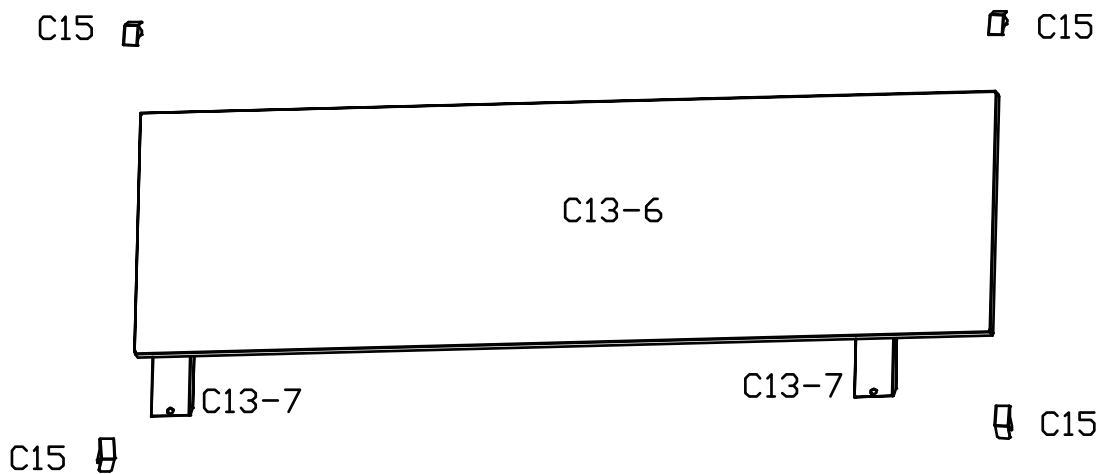
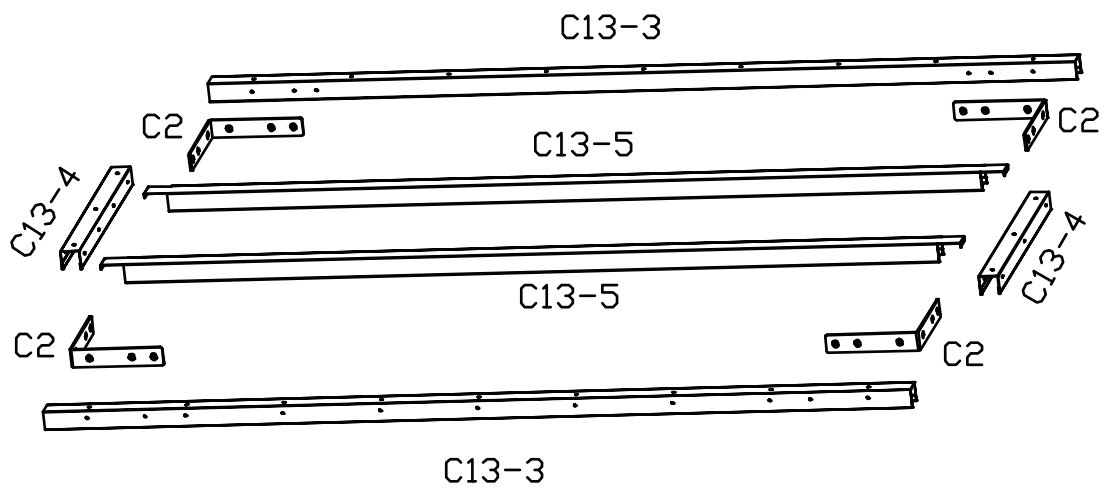
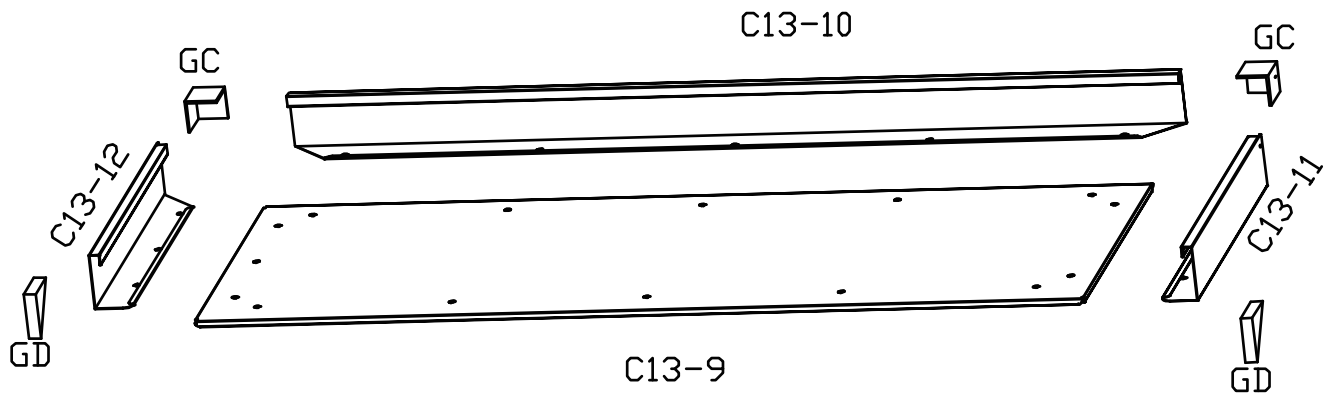

Part List

NOTE: This is **not the beginning** of the installation steps; it is merely to indicate where each component will be installed.



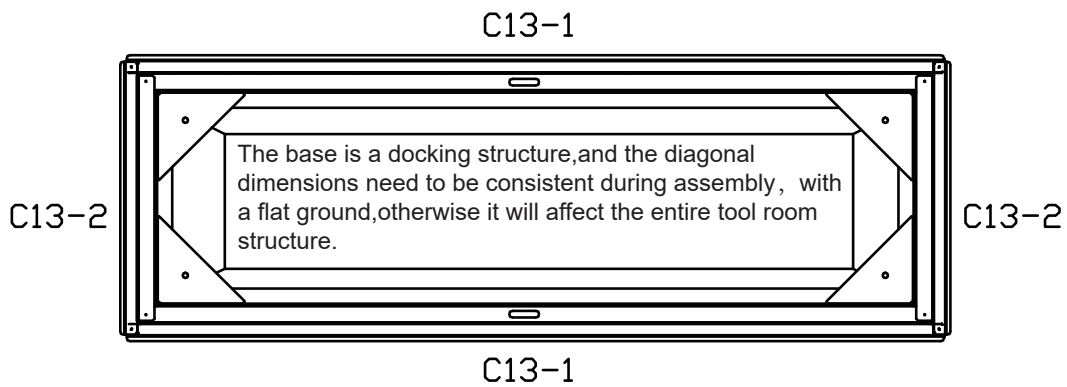
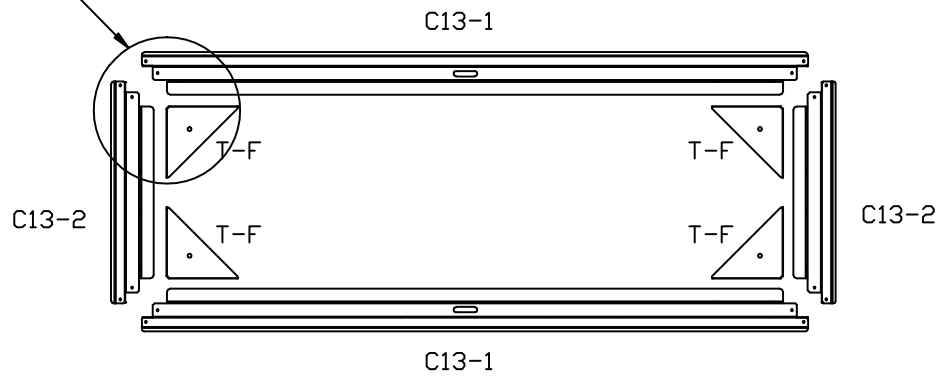
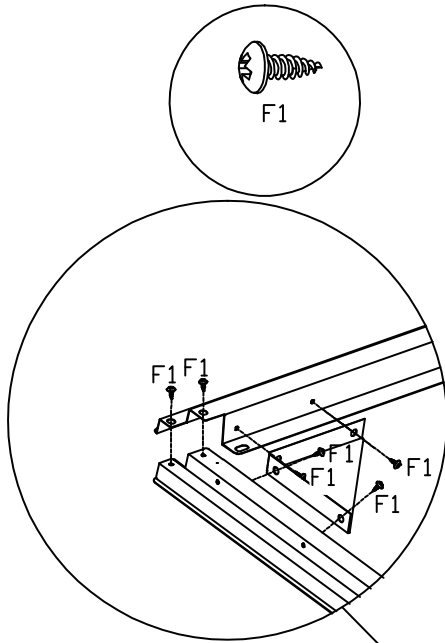

Shed Base Assemble

PART	NO.	QTY.
	C13-1	2
	C13-2	2
	T-F	4
	F1	24



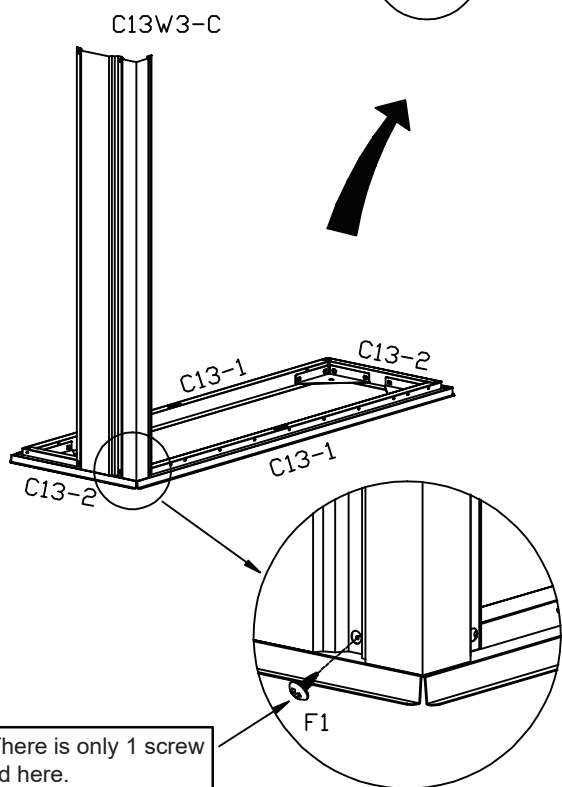
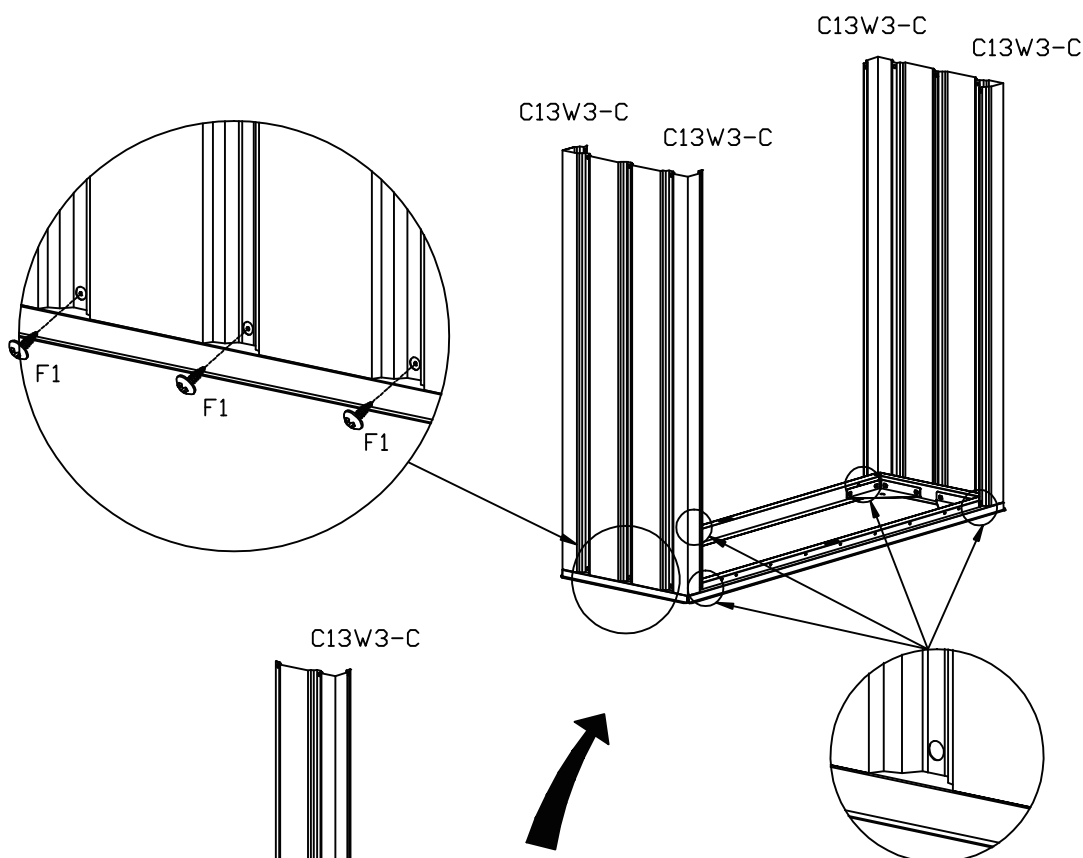
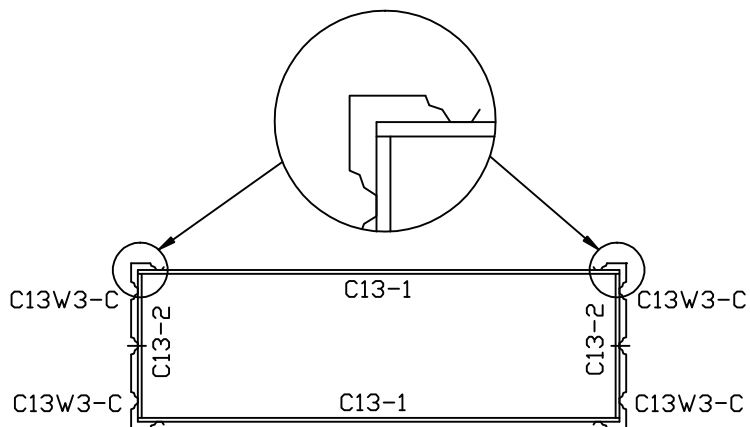

Side Panel Assemble

PART	NO.	QTY.
	C13W3-C	4
	F1	6





Note: These 4 places are not allowed to install screws

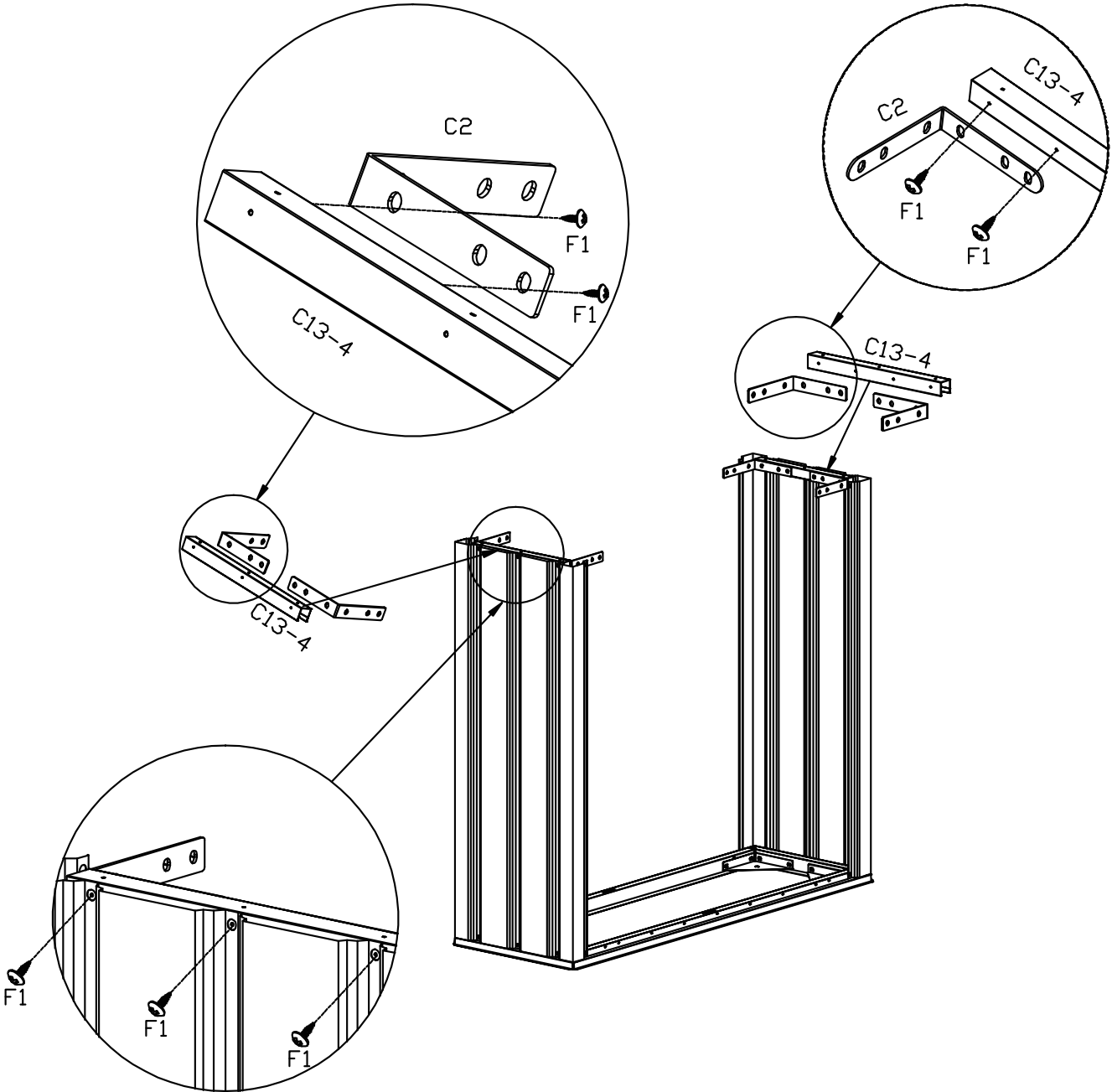

Note: There is only 1 screw installed here.

PART	NO.	QTY.
	C13-4	2
	C2	4
	F1	14

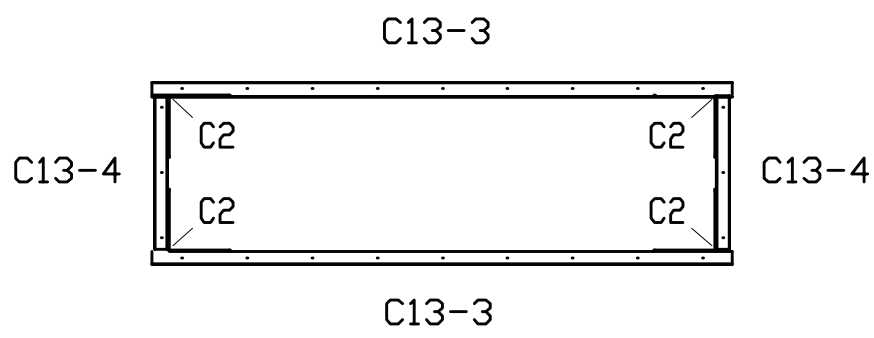
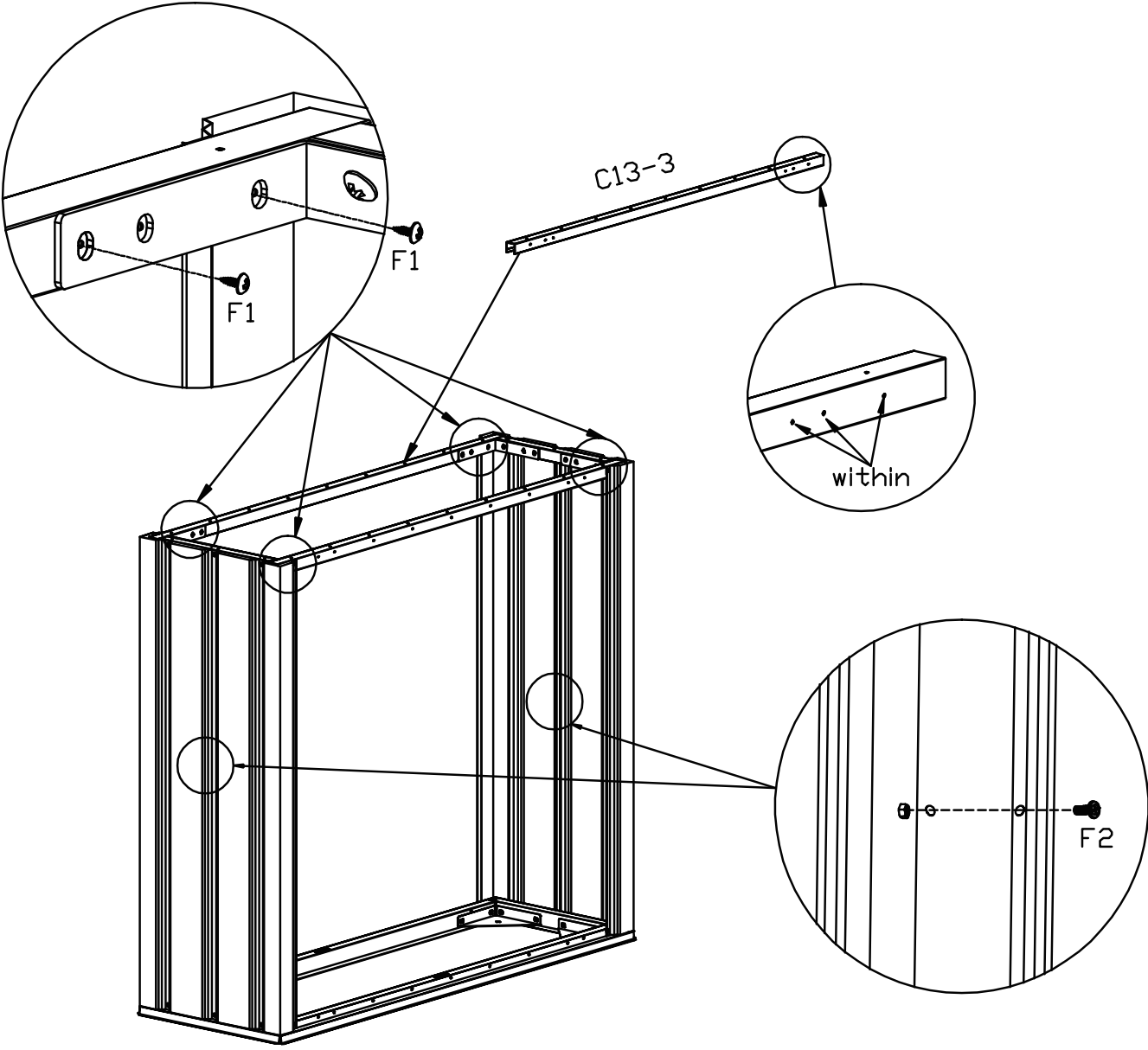

PART	NO.	QTY.
	C13-3	2
	F1	8
	F2	2

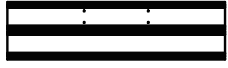

PART	NO.	QTY.
	C13-8	2
	C13W3-B	2
	F2	8

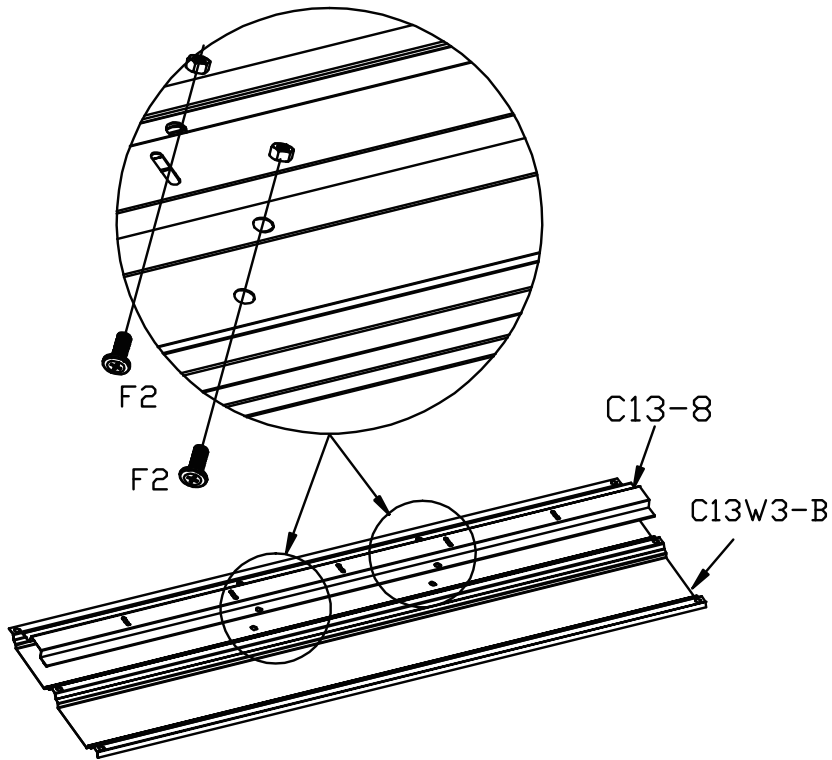



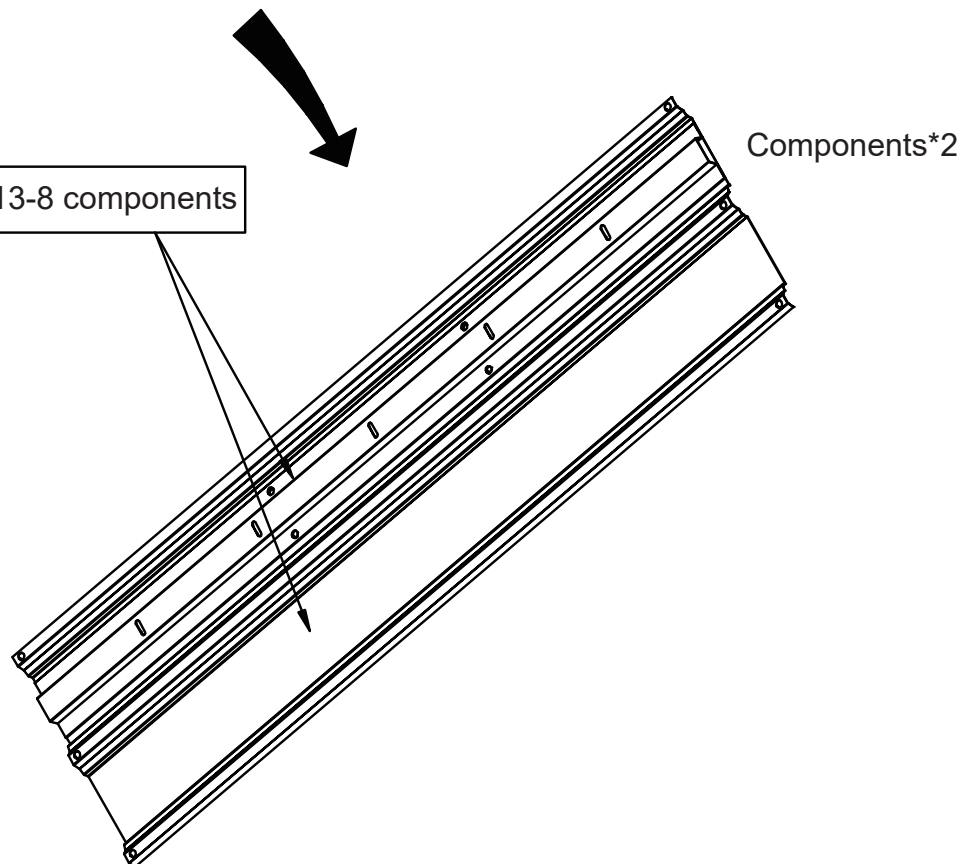

C13W3-B with C13-8 components



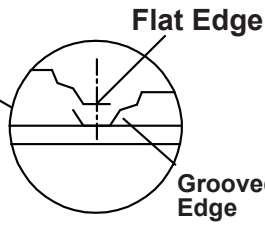
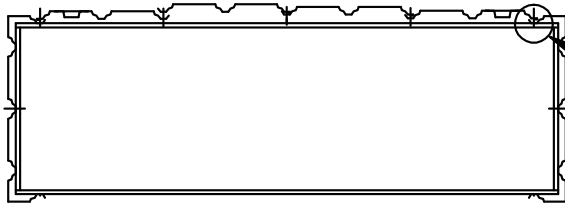



Top Panel Assemble

C13W3-B C13-W3 C13-W3 C13W3-B

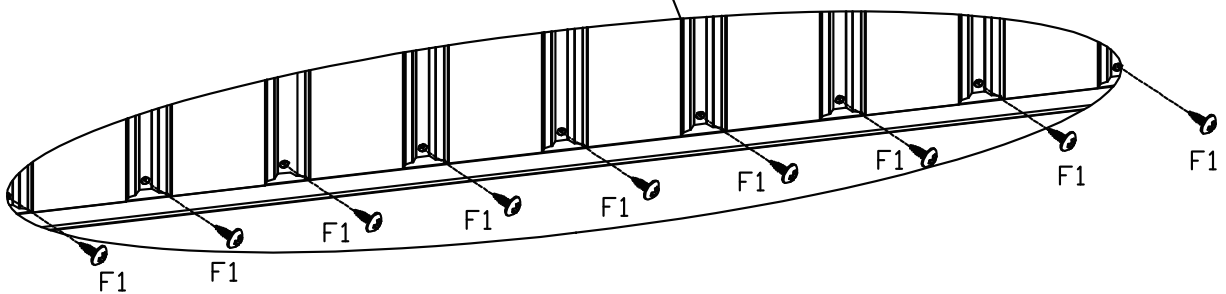
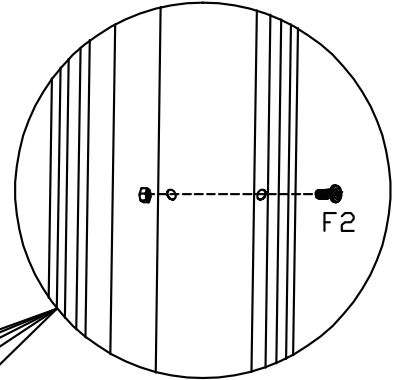
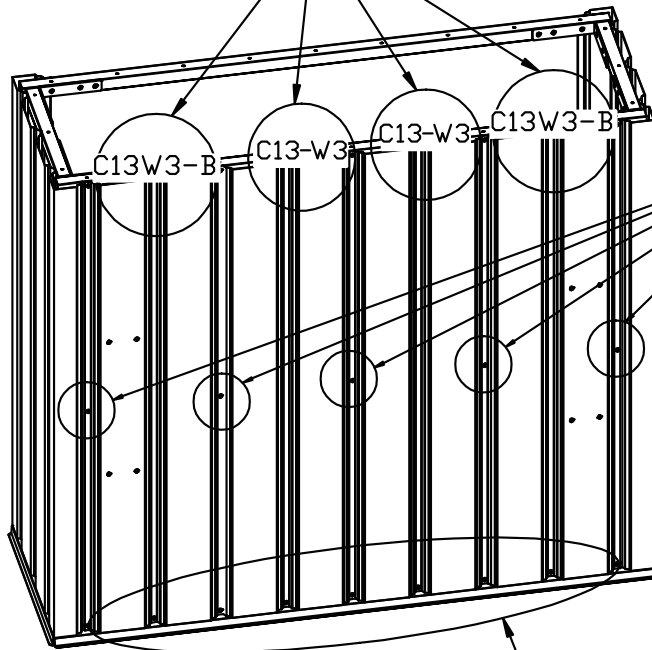
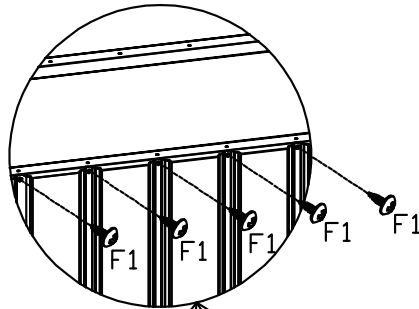



PART	NO.	QTY.
	C13W3-B with C13-8 components	2
	C13-W3	2
	F1	18
	F2	5



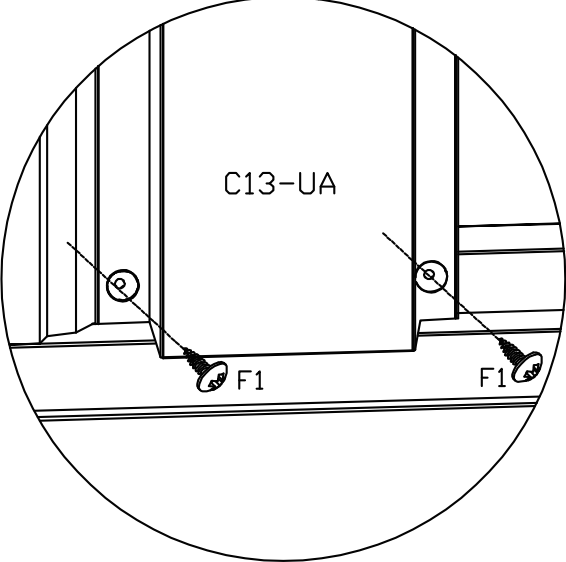
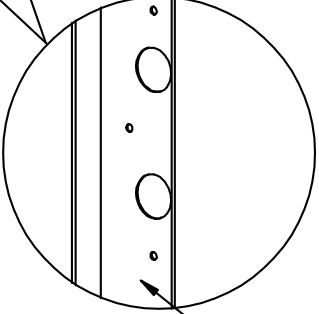
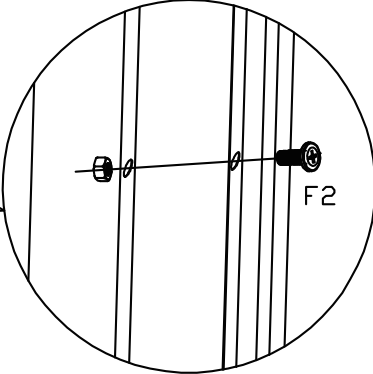
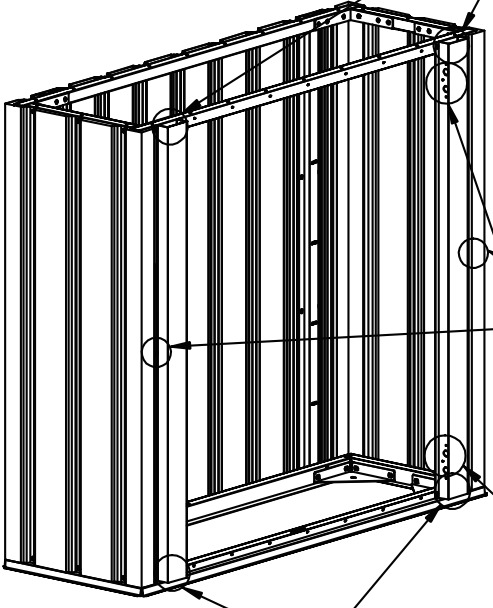
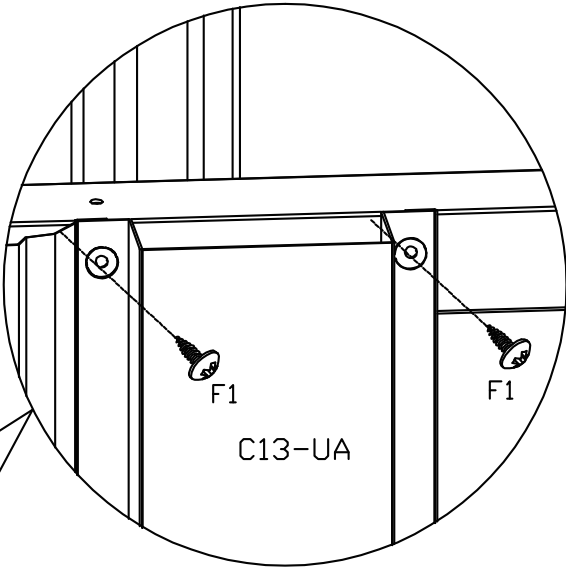
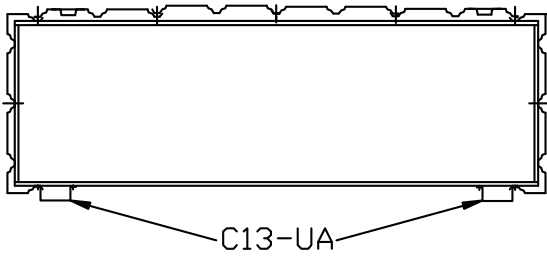

PART	NO.	QTY.
	C13-UA	2
	F1	8
	F2	2

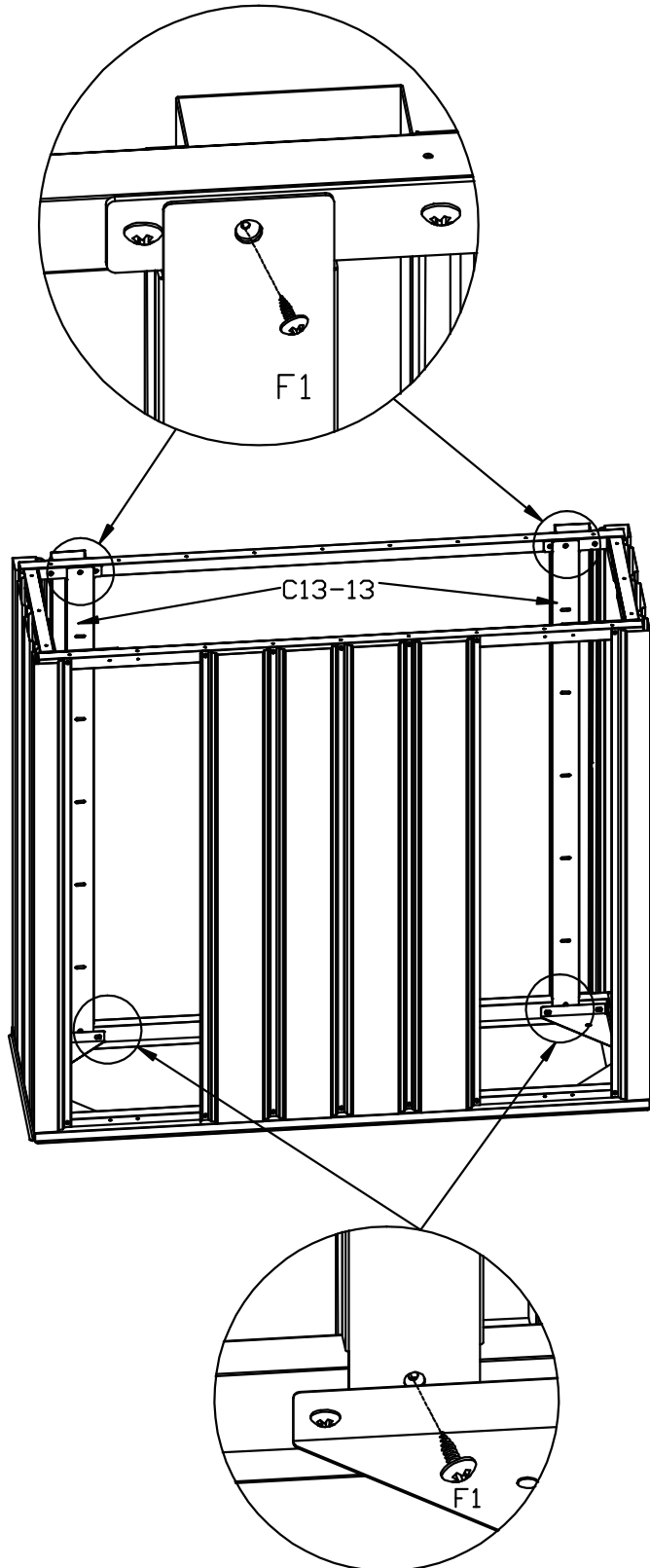

Note the direction: the inside is the hinge mounting hole!

PART	NO.	QTY.
	C13-13	2
	F1	4







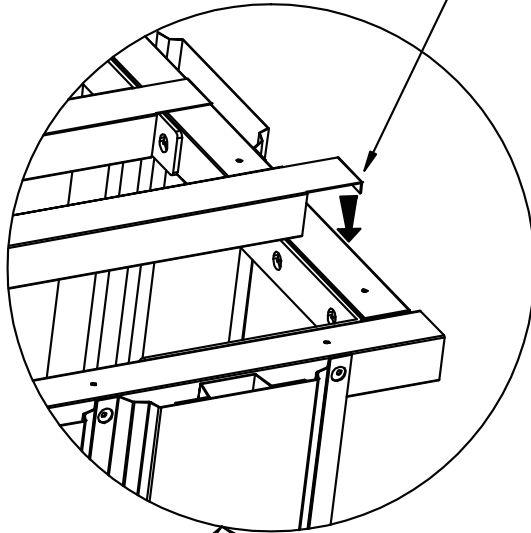

PART	NO.	QTY.
	C13-5	2

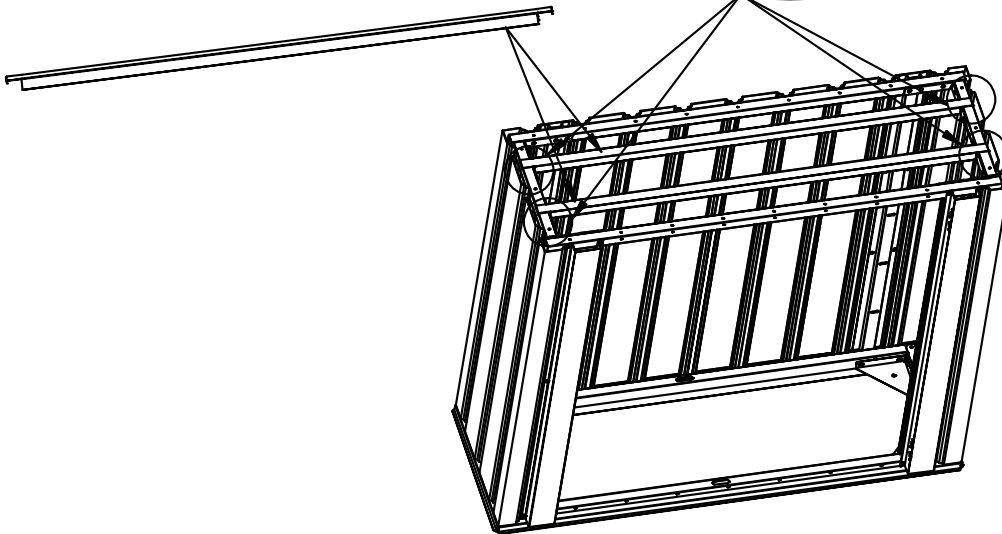
Installation: Notch snap into C13-4 (4 places)

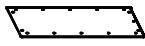





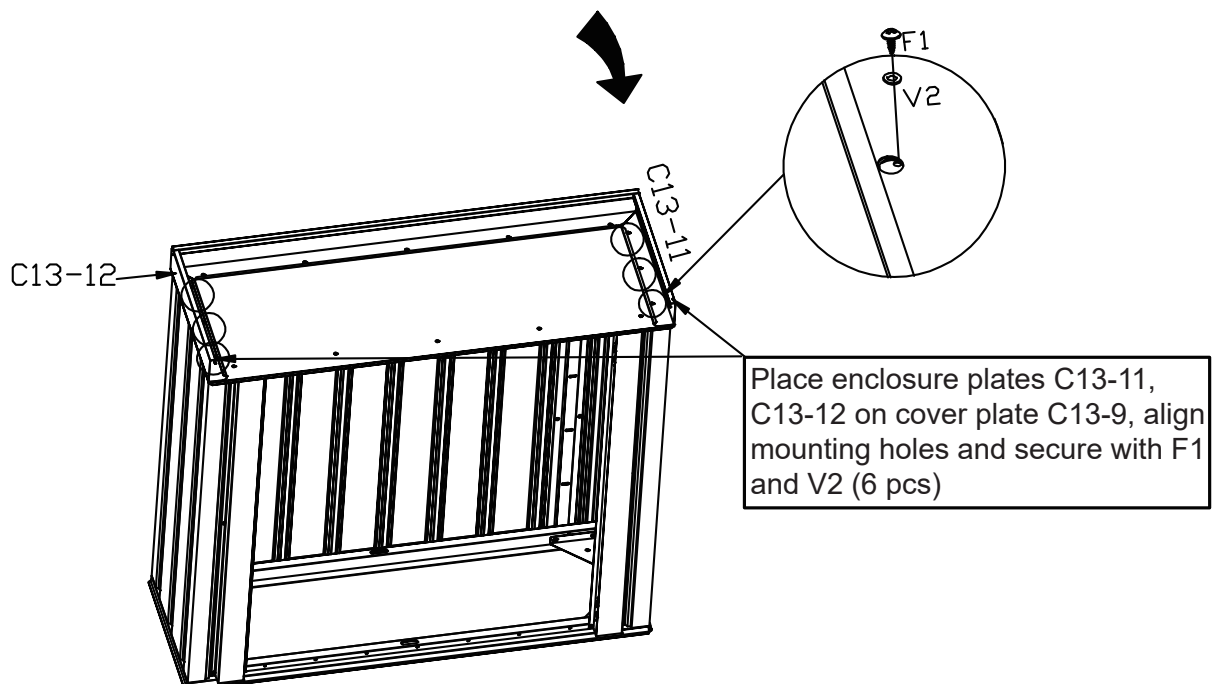
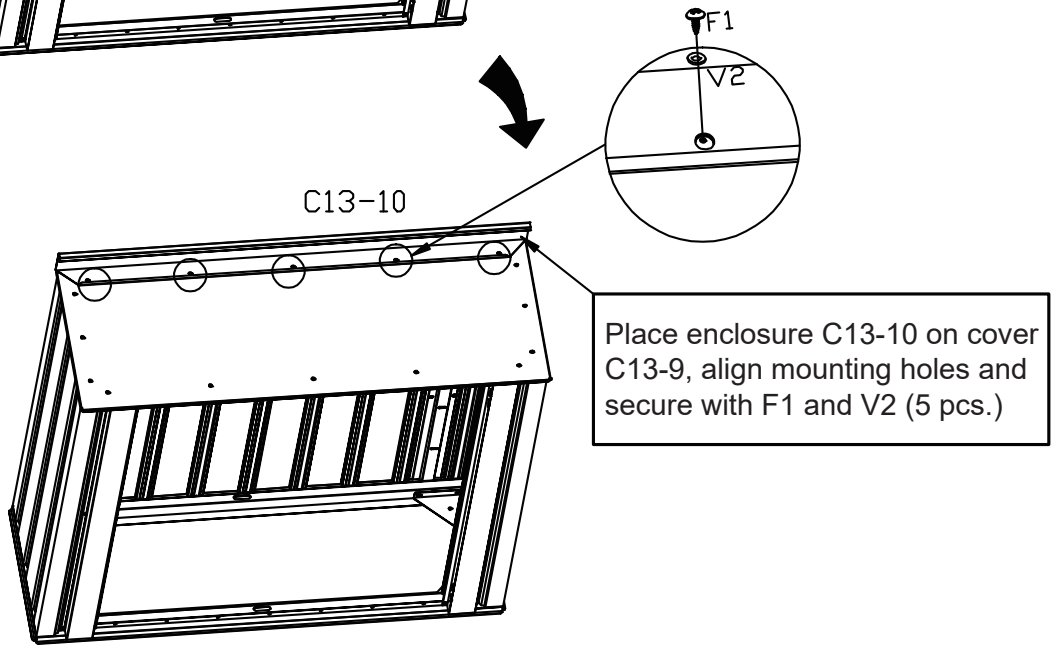
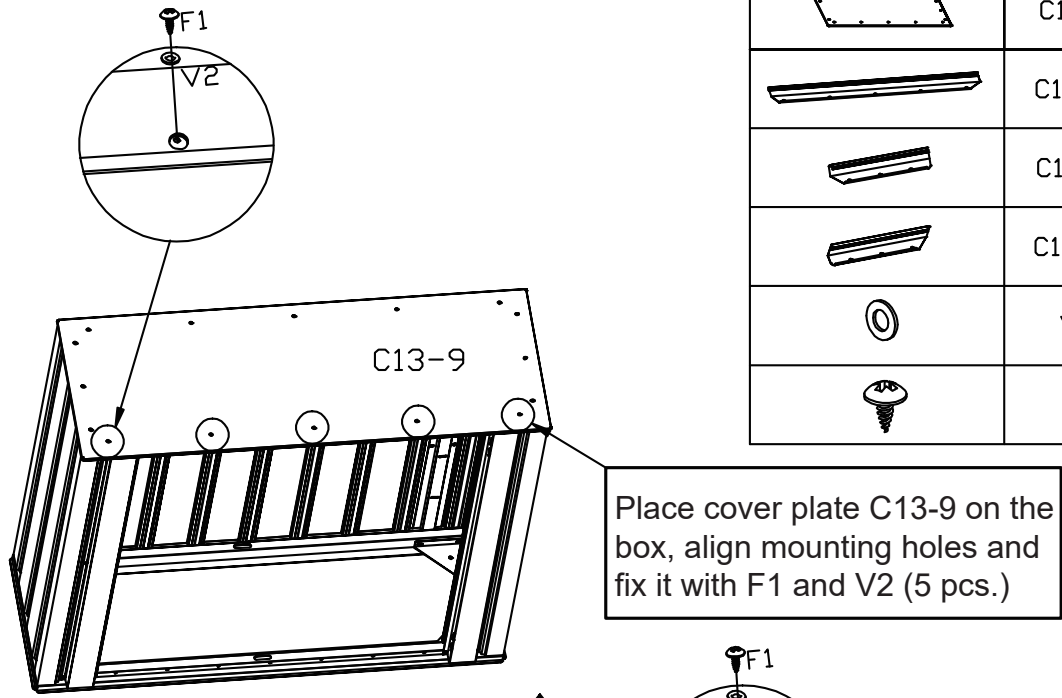

2*C13-5





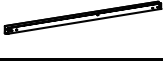
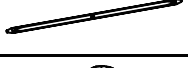



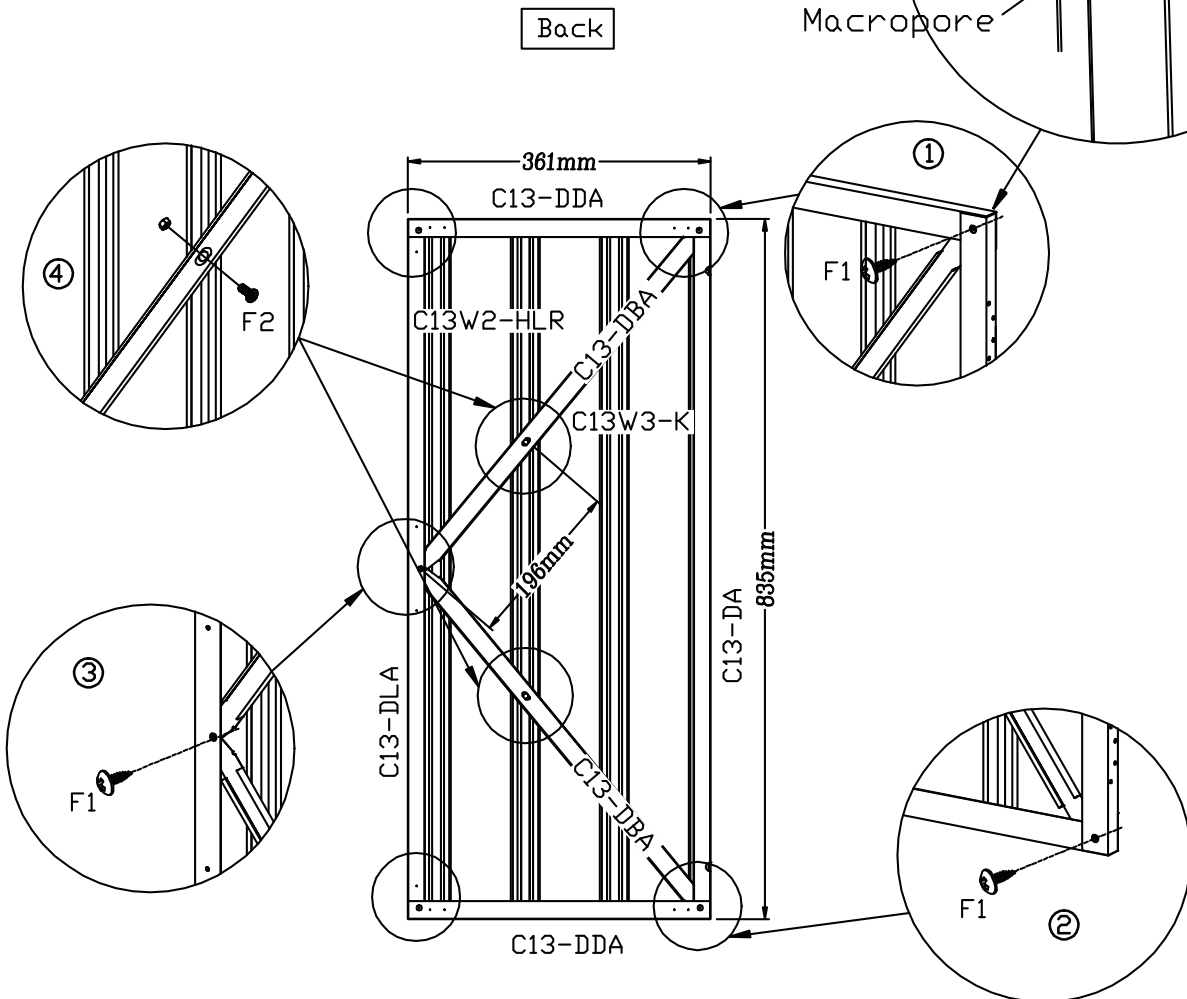
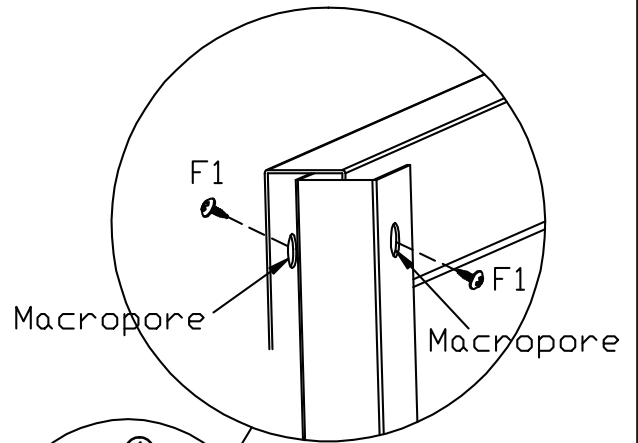
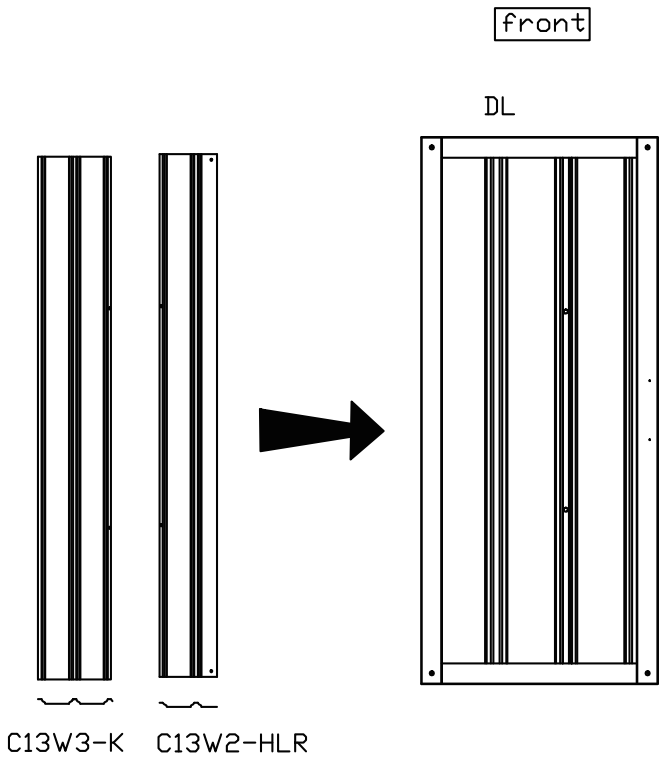

PART	NO.	QTY.
	C13-9	1
	C13-10	1
	C13-11	1
	C13-12	1
	V2	16
	F1	16



PART	NO.	QTY.
	C13W3-K	1
	C13W2-HLR	1
	C13-DA	1
	C13-DLA	1
	C13-DDA	2
	C13-DBA	2
	F1	9
	F2	2



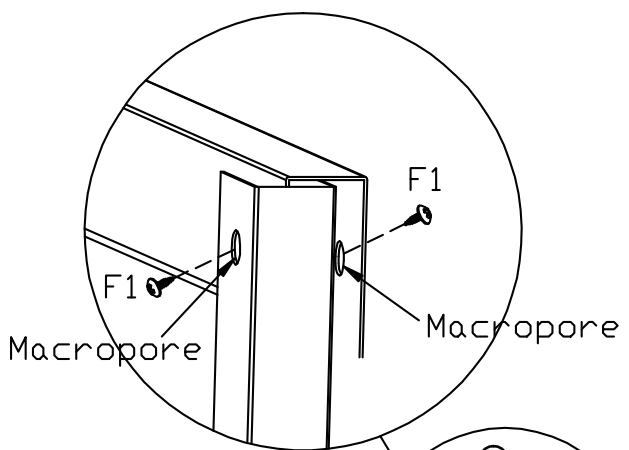
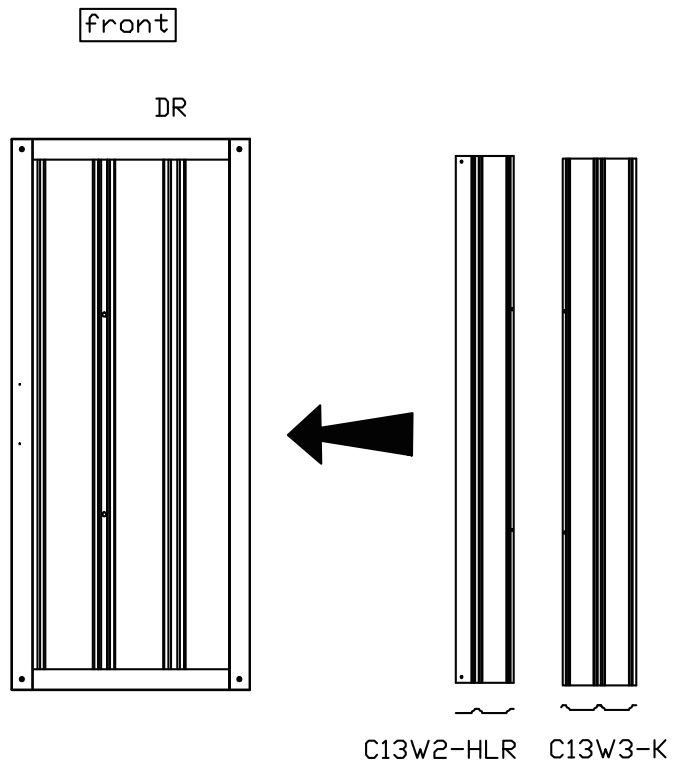

PART	NO.	QTY.
	C13W3-K	1
	C13W2-HLR	1
	C13-DA	1
	C13-DRA	1
	C13-DDA	2
	C13-DBA	2
	F1	9
	F2	2



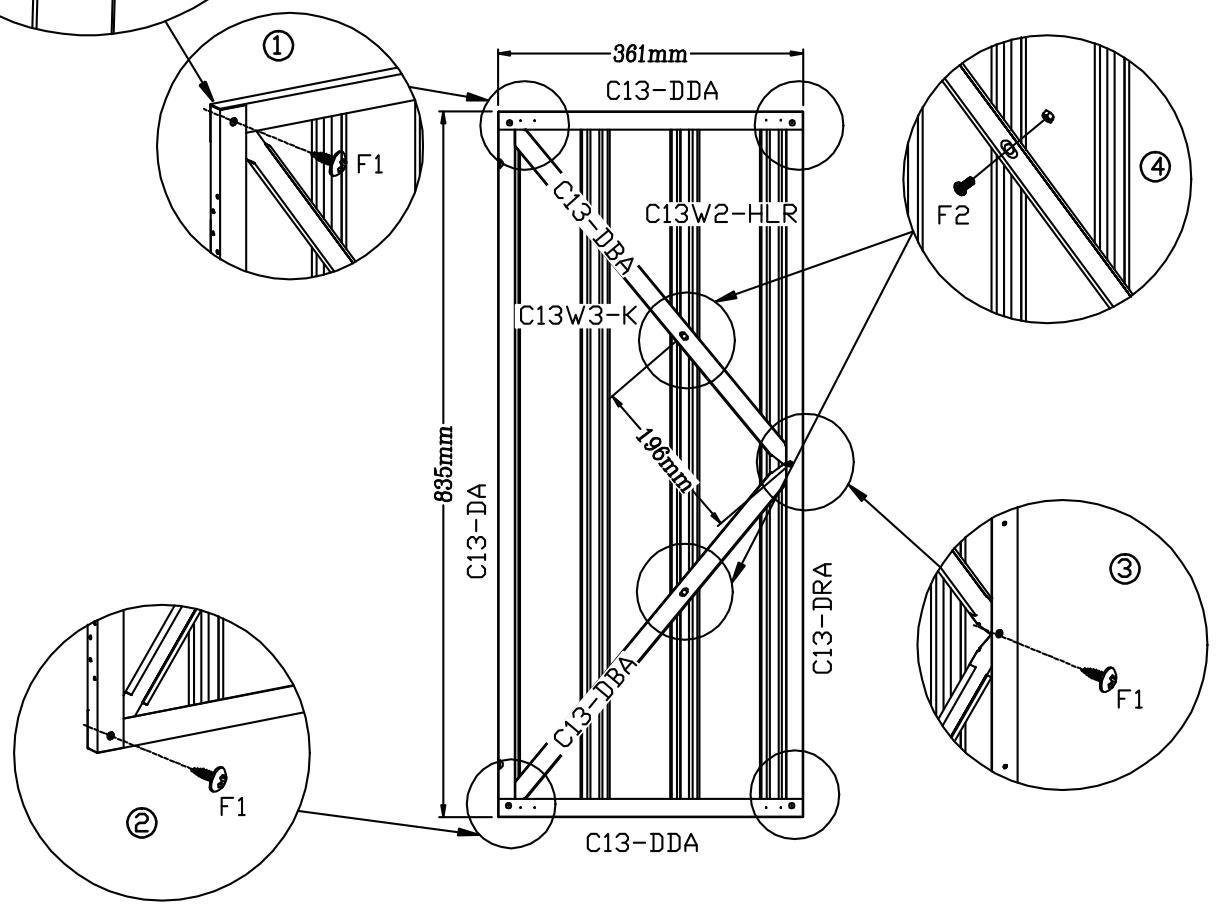



Back



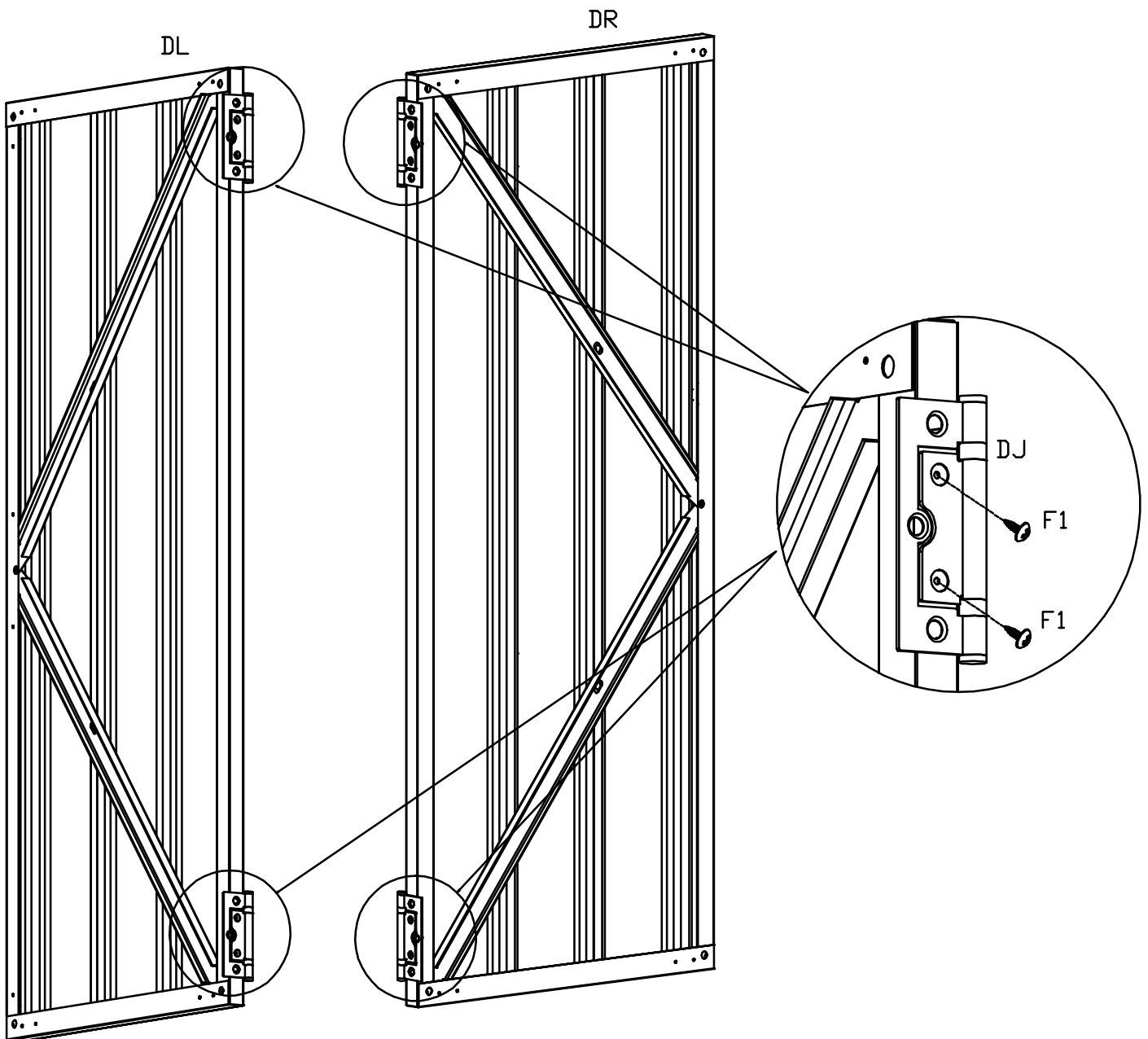



Door Assemble

PART	NO.	QTY.
	DJ	4
	F1	8

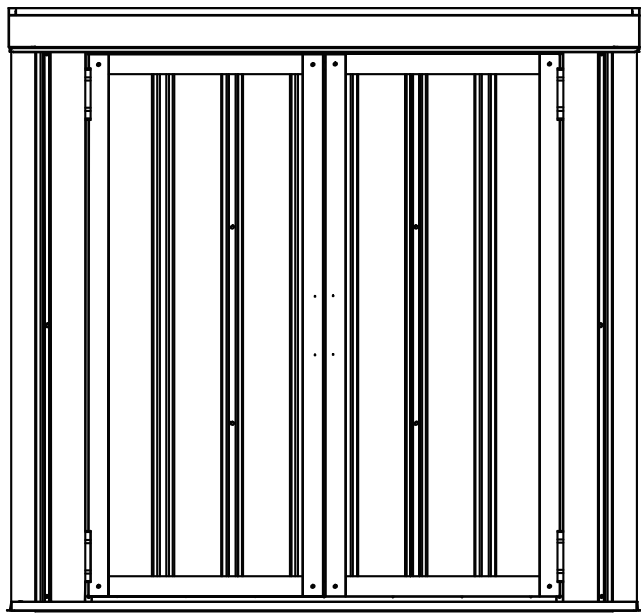
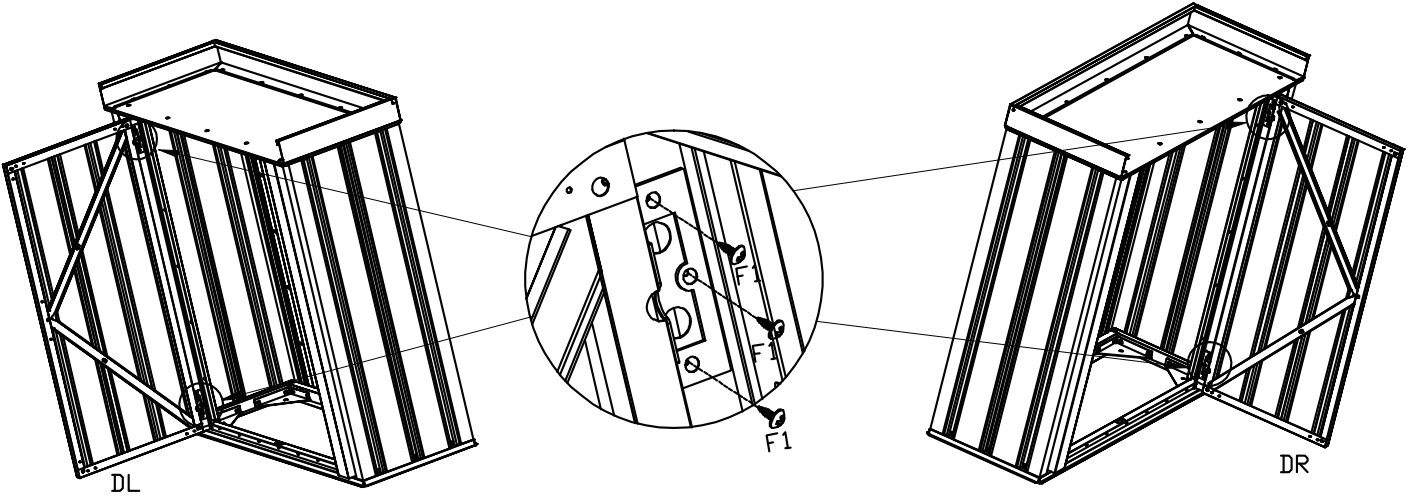

PART	NO.	QTY.
	DL	1
	DR	1
	F1	12





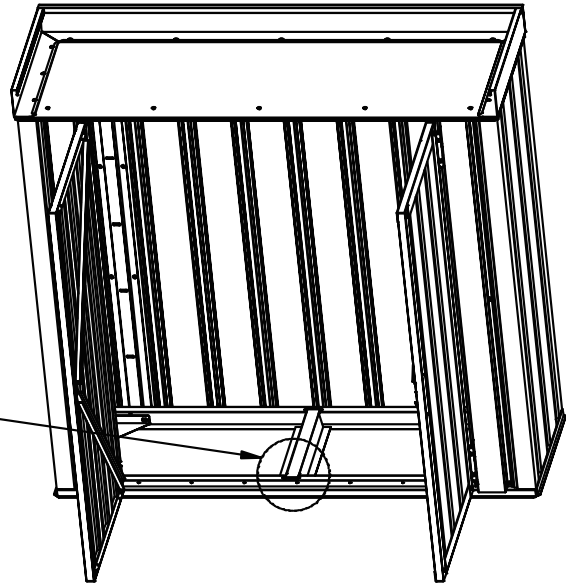
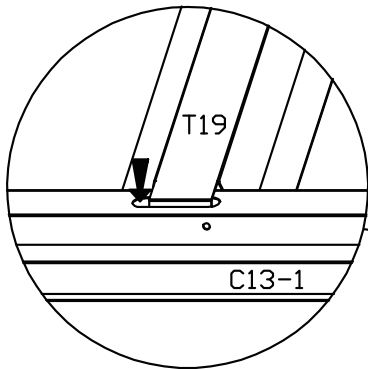

PART	NO.	QTY.
	T19	1
	C13-6	1
	C13-7	2
	F1	4

Installation: Snap T19 into C13-1.

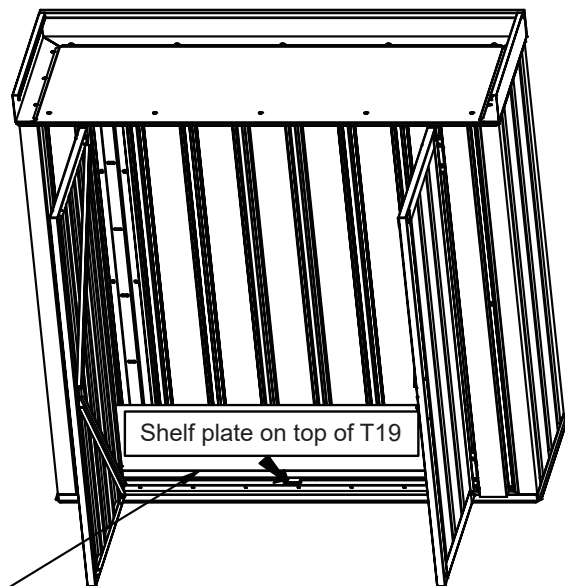
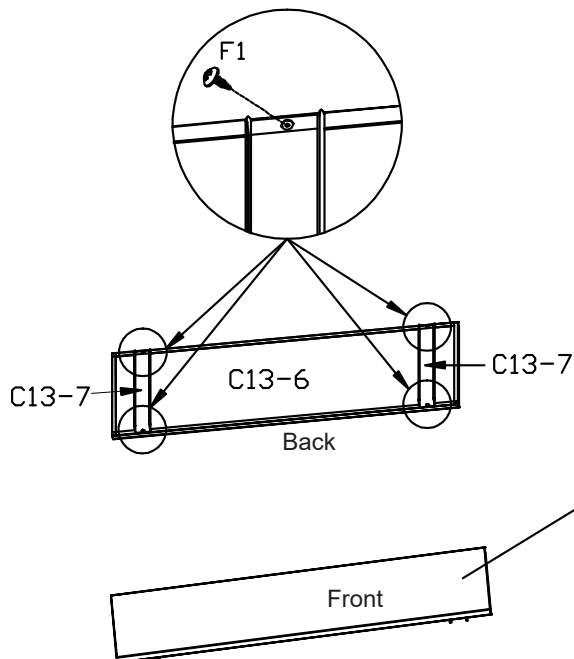

C13-6 is connected to C13-7 with F1 self-tapping screws as a shelf in the box.





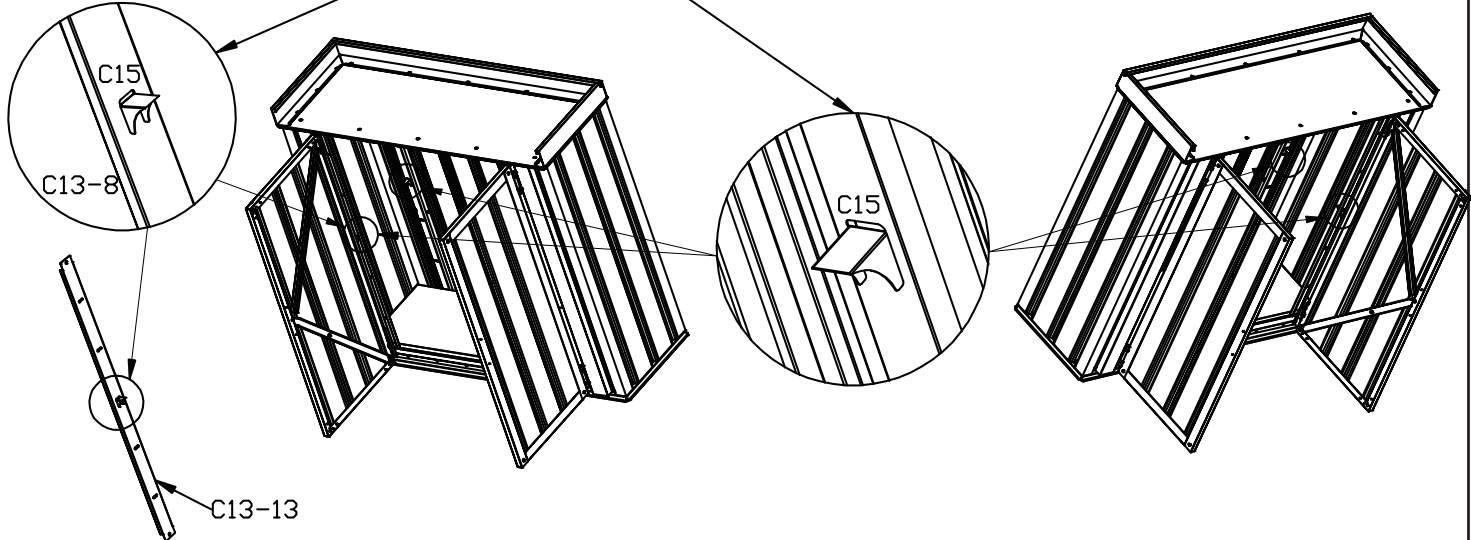

PART	NO.	QTY.
	C15	4
	C13-6	1
	C13-7	2
	F1	4

C15 hangers, hanging on the back C13-8 and front C13-13 equal height holes for shelf support.

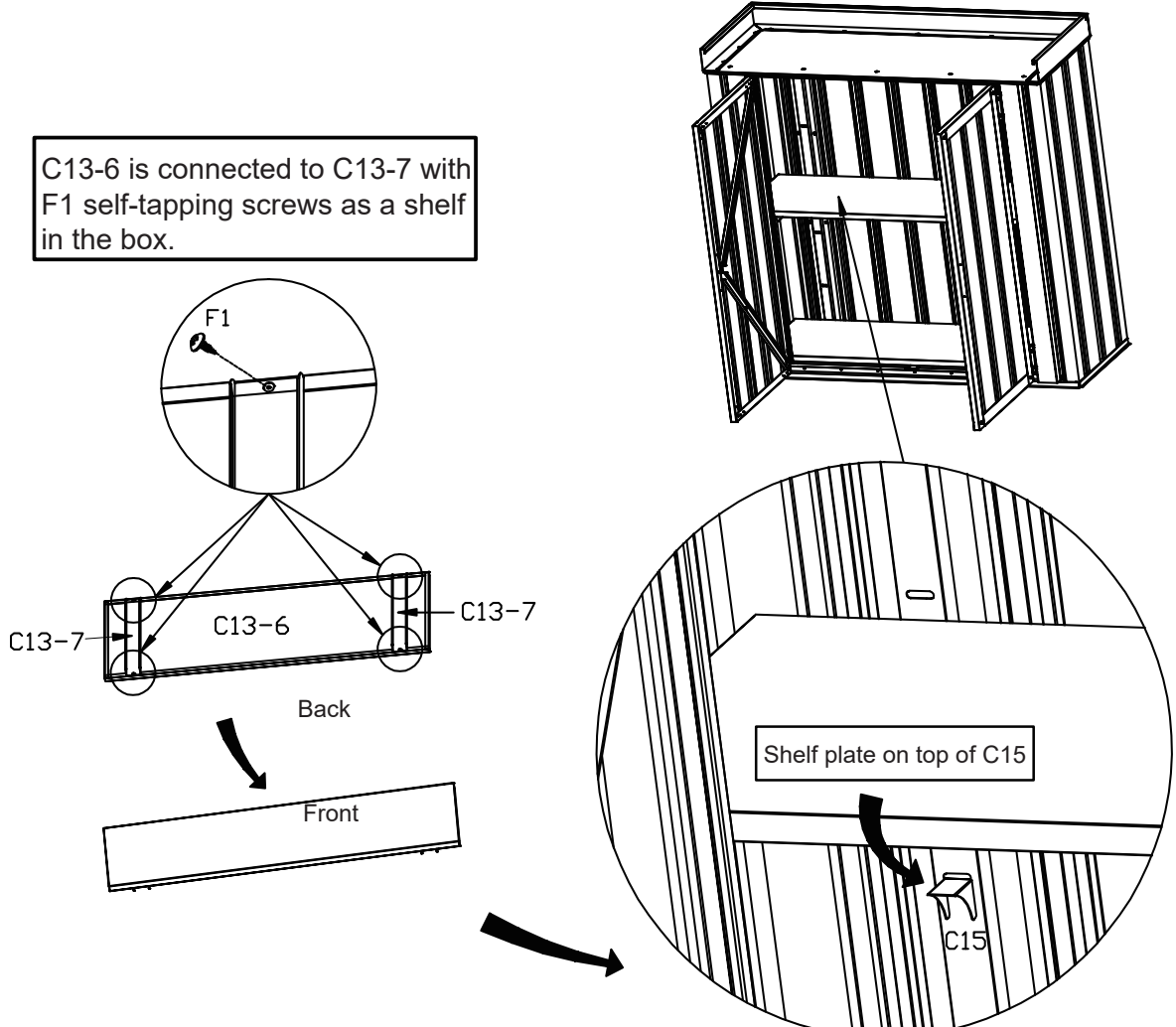





C13-6 is connected to C13-7 with F1 self-tapping screws as a shelf in the box.

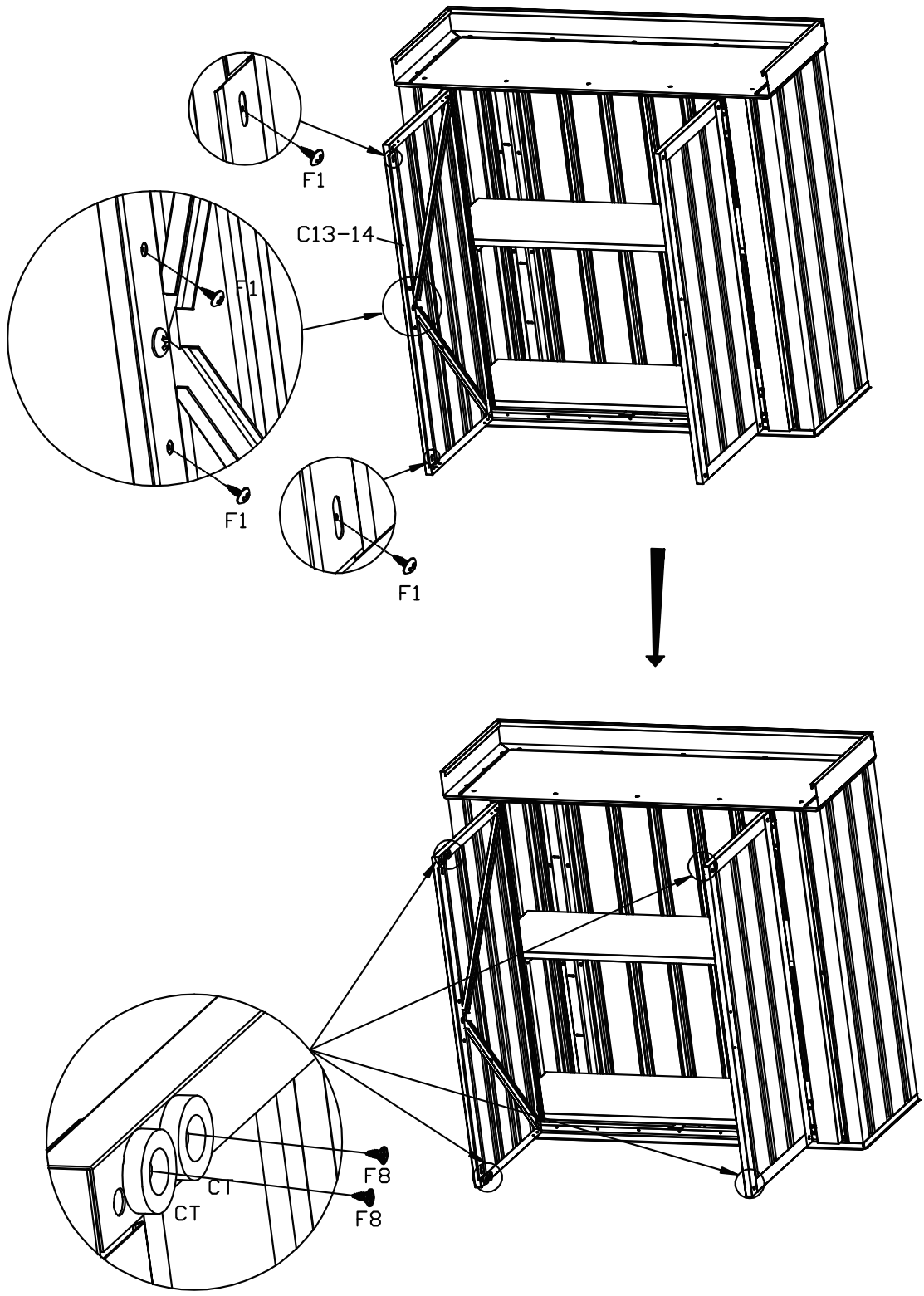

PART	NO.	QTY.
	C13-14	1
	CT	8
	F1	4
	F8	8



PART	NO.	QTY.
	GB	2
	GC	2
	GD	2
	F1	6

