

# ASSEMBLY INSTRUCTIONS

## Chair

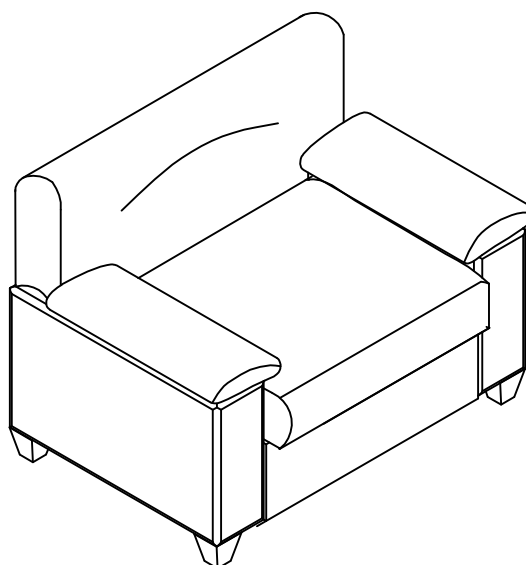



### NOTE TO CUSTOMERS:

- For ease and speed of assembly we recommend that before you commence each step of the assembly that you identify all the parts required to complete that step.
- We recommend that where possible you allow sufficient space to assemble the item as close as possible to the place where it will be once assembled.
- For the protection of your furniture we recommend that the product is placed on protected surfaces during assembly to prevent any damage.
- During assembly do not over tighten, as this may damage the product.
- Please ensure you retain all the product packaging until the item completely assembled.
- Please periodically check all fittings and re-tighten as necessary.
- It is recommended that this item should be assembled by two adults.

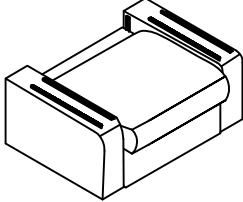
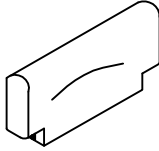
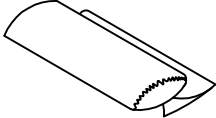
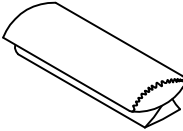
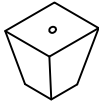
# Part List

<p>A1. <span style="float: right;">Quantity of 1</span></p> <div style="text-align: center;">  </div> <p>Seat Panel</p>	<p>A2. <span style="float: right;">Quantity of 1</span></p> <div style="text-align: center;">  </div> <p>Back Panel</p>	
<p>A3-L. <span style="float: right;">Quantity of 1</span></p> <div style="text-align: center;">  </div> <p>Left Armrest</p>	<p>A3-R. <span style="float: right;">Quantity of 1</span></p> <div style="text-align: center;">  </div> <p>Right Armrest</p>	<p>A4. <span style="float: right;">Quantity of 4</span></p> <div style="text-align: center;">  </div> <p>Leg</p>

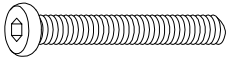
# Hardware List

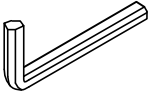
<p>B1</p> <div style="text-align: center;">  </div> <p>Bolt</p>	<p style="text-align: right;">Quantity of 4</p> <div style="text-align: center;">  </div> <p>Flat Washer</p>
<p>B2 <span style="float: right;">Quantity of 1</span></p> <div style="text-align: center;">  </div>	

# STEP 1

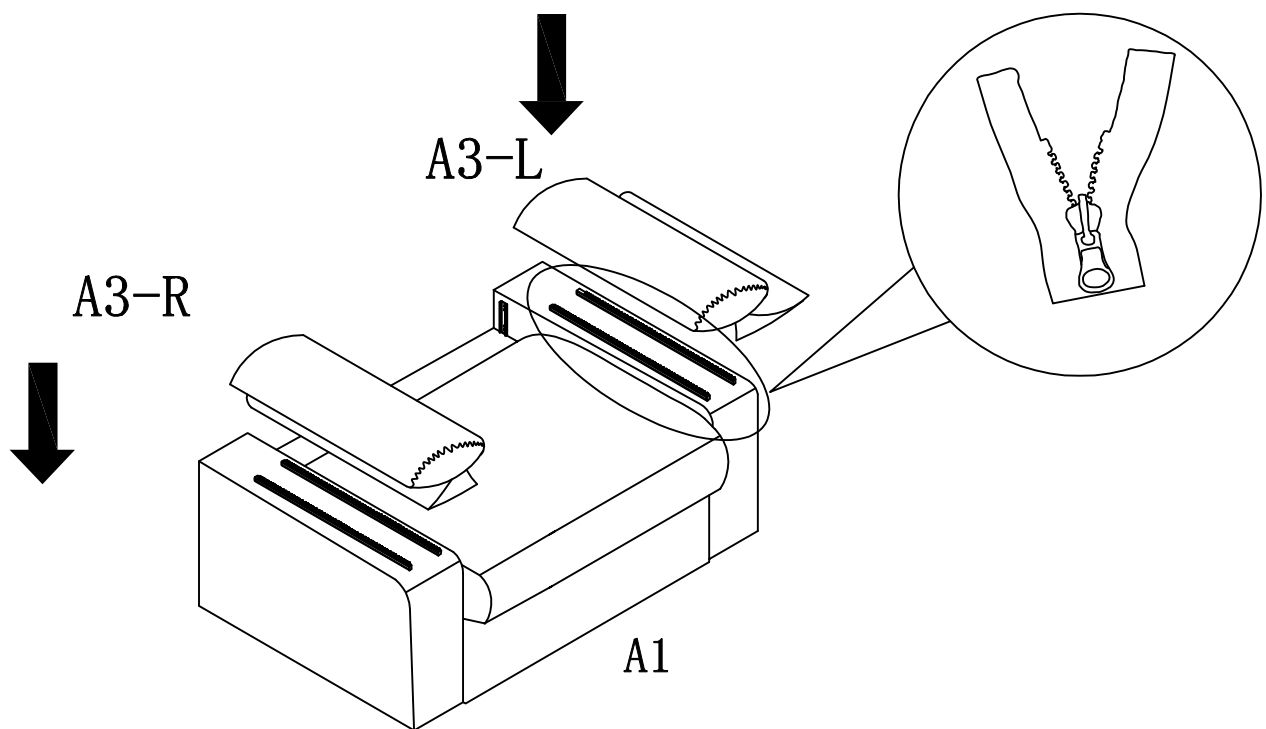

Attach Armrests A3 (L&R) to Seat Panel A1 as shown above.

## STEP 2

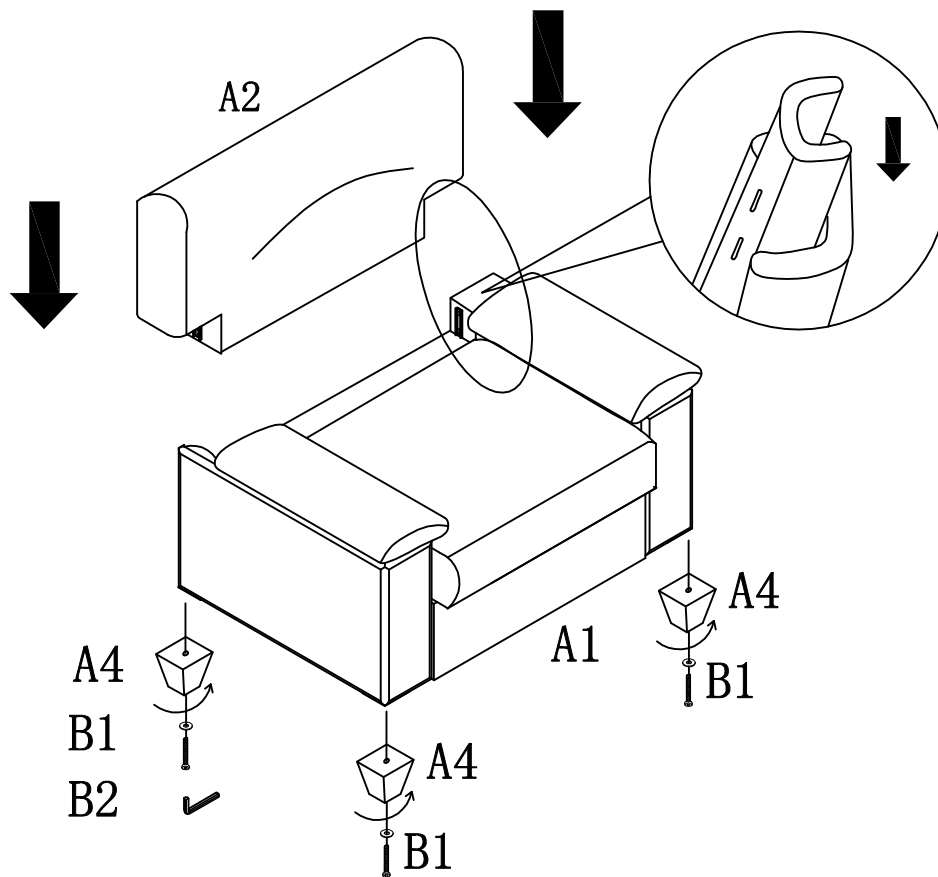

1. Attach Legs A4 to the bottom of Seat Panel A1 using Bolts B1 with washers.
2. Attach Back Panel A2 to Seat Panel A1 as above drawing shown.