

N625P283137S / N625P283138S

Product manual

Gebrauchsanweisung

Manuel du produit

Manual del producto

Manuale del prodotto

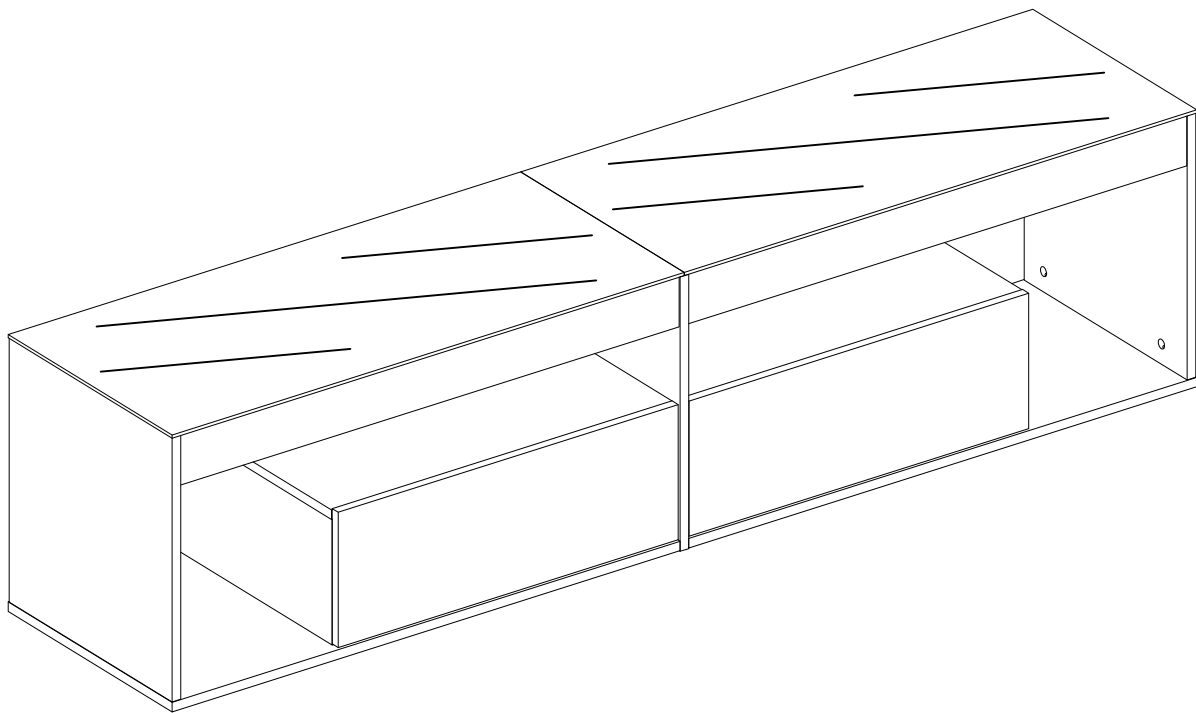

EN:Our product will be delivered to you in 2 packages.
The delivery times of these 2 packages may differ, please
be patient and thank you for your understanding

FR:Notre produit vous sera livré en 2 colis. Les délais de
livraison de ces 2 colis peuvent différer, soyez
patient et merci de votre compréhension.

DE:Unser Produkt wird Ihnen in 2 Paketen geliefert. Die
Lieferzeiten dieser 2 Pakete können abweichen, bitte haben
Sie etwas Geduld und vielen Dank für Ihr Verständnis

IT:I nostri prodotti vengono trasportati in due pacchetti. I
tempi di consegna dei due pacchetti sono diversi:
abbiate pazienza e vi ringrazio per la vostra comprensione

ES:Nuestro producto se entrega en dos paquetes. El
tiempo de entrega de estos dos paquetes es diferente. Por
favor, sea paciente. Gracias por su comprensión.

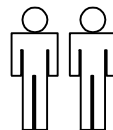

2PERS

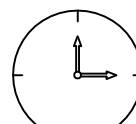

60MIN

Tool Required Not Provided

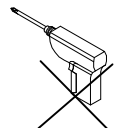



[DE]

Warnung: Lesen Sie diese Anleitung vor dem Zusammenbau bitte vollständig durch. Überprüfen Sie, ob Sie alle auf den Seiten aufgeführten Komponenten und Werkzeuge haben. Bewahren Sie die Anleitung zum späteren Nachschlagen auf. Teile des Zusammenbaus lassen sich mit 2 Personen leichter durchführen. Suchen Sie bei Bedarf professionelle Hilfe.

Warnung: Legen Sie alle Teile auf eine ebene Fläche. Legen Sie eine weiche Decke oder Ähnliches darunter, um sie vor Kratzern oder Flecken zu schützen. Vermeiden Sie es, Komponenten über den Boden zu ziehen oder zu schieben.

Warnung: Überprüfen Sie regelmäßig alle Beschläge und Befestigungen, um sicherzustellen, dass sie sicher sind und um Unfälle zu vermeiden. Wenn Teile fehlen, kaputt, beschädigt oder abgenutzt sind, verwenden Sie das Produkt nicht weiter, bis es mit vom Hersteller autorisierten Teilen repariert wurde.

Warnung: Lassen Sie Kinder nicht auf die Möbel klettern, da dies zum Umkippen und zu schweren Verletzungen führen kann. Bauen Sie die Möbel außerhalb der Reichweite von Kindern zusammen.

Warnung: Stellen Sie die Möbel nicht in die Nähe von Feuerquellen oder heißen Gegenständen, um Brandgefahr zu vermeiden.

Warnung: Reinigen Sie die Möbel mit einem feuchten Tuch oder Alkohol. Verwenden Sie keine Reinigungsmittel mit ätzenden Chemikalien.

Warnung: Dieses Produkt ist mit einer Kippschutzvorrichtung ausgestattet. Bitte installieren Sie diese Vorrichtung unbedingt, um unnötige Verletzungen durch Umkippen zu vermeiden.

[EN]

Warning: Please read these instructions fully before starting assembly. Check you have all the components and tools listed on pages. Keep the instructions for later reference. Parts of the assembly will be easier with 2 people. Seek professional assistance if necessary.

Warning: Please place all parts on a flat surface. Place a soft blanket or similar underneath to protect against scratches or stains. Avoid dragging or sliding components across the floor.

Warning: Regularly check all fittings and fastenings to ensure they are secure and to prevent accidents. If any parts are missing, broken, damaged, or worn, discontinue use of the product until repairs have been made using factory authorized parts.

Warning: Do not allow children to climb on the furniture as this may result in tipping and serious personal injury. Assemble the furniture away from the reach of children.

Warning: Do not place furniture close to fire sources or high-temperature objects to avoid the risk of fire. Do not place furniture in damp environments to prevent material damage.

Warning: Clean furniture with a damp cloth or alcohol, avoid using cleaning agents containing corrosive chemicals.

Warning: This product is equipped with an anti-tilt device. Please be sure to install this device to prevent unnecessary injuries caused by tipping.

[FR]

Avertissement : Veuillez lire attentivement ces instructions avant de commencer l'assemblage. Vérifiez que vous disposez de tous les composants et outils répertoriés sur les pages. Conservez les instructions pour référence ultérieure. Certaines parties de l'assemblage seront plus faciles à 2 personnes. Demandez l'aide d'un professionnel si nécessaire.

Avertissement : Veuillez placer toutes les pièces sur une surface plane. Placez une couverture douce ou similaire en dessous pour les protéger des rayures ou des taches. Évitez de faire glisser les composants sur le sol.

Avertissement : Vérifiez régulièrement tous les raccords et fixations pour vous assurer qu'ils sont bien fixés et

pour éviter les accidents. Si des pièces manquent, sont cassées, endommagées ou usées, cessez d'utiliser le produit jusqu'à ce que des réparations aient été effectuées à l'aide de pièces autorisées par l'usine.

Avertissement : Ne laissez pas les enfants grimper sur les meubles car cela pourrait entraîner un basculement et des blessures graves. Assemblez les meubles hors de portée des enfants.

Avertissement : Ne placez pas les meubles à proximité de sources de feu ou d'objets à haute température pour éviter tout risque d'incendie.

Avertissement : Nettoyez les meubles avec un chiffon humide ou de l'alcool, évitez d'utiliser des produits de nettoyage contenant des produits chimiques corrosifs.

Avertissement : Ce produit est équipé d'un dispositif anti-basculement. Assurez-vous d'installer ce dispositif pour éviter les blessures inutiles causées par un basculement.

[IT]

Attenzione: leggere attentamente queste istruzioni prima di iniziare il montaggio. Verificare di avere tutti i componenti e gli strumenti elencati nelle pagine. Conservare le istruzioni per riferimento futuro. Alcune parti del montaggio saranno più facili con 2 persone. Se necessario, chiedere assistenza professionale.

Attenzione: posizionare tutte le parti su una superficie piana. Posizionare una coperta morbida o simile sotto per proteggere da graffi o macchie. Evitare di trascinare o far scivolare i componenti sul pavimento.

Attenzione: controllare regolarmente tutti i raccordi e i dispositivi di fissaggio per assicurarsi che siano sicuri e per prevenire incidenti. Se alcune parti sono mancanti, rotte, danneggiate o usurate, interrompere l'uso del prodotto fino a quando non siano state eseguite le riparazioni utilizzando parti autorizzate dalla fabbrica.

Attenzione: non consentire ai bambini di arrampicarsi sui mobili poiché ciò potrebbe causare ribaltamenti e gravi lesioni personali. Montare i mobili lontano dalla portata dei bambini.

Attenzione: non posizionare i mobili vicino a fonti di fuoco o oggetti ad alta temperatura per evitare il rischio di incendio

Attenzione: pulire i mobili con un panno umido o alcol, evitare di utilizzare detergenti contenenti sostanze chimiche corrosive.

Attenzione: questo prodotto è dotato di un dispositivo antiribaltamento. Assicurarsi di installare questo dispositivo per prevenire lesioni inutili causate dal ribaltamento.

[ES]

Advertencia: Lea estas instrucciones completamente antes de comenzar el montaje. Compruebe que tiene todos los componentes y herramientas que se enumeran en las páginas. Conserve las instrucciones para consultarlas más adelante. El montaje de algunas partes será más sencillo con 2 personas. Busque ayuda profesional si es necesario.

Advertencia: Coloque todas las piezas sobre una superficie plana. Coloque una manta suave o algo similar debajo para protegerlas de rayones o manchas. Evite arrastrar o deslizar los componentes por el piso.

Advertencia: Verifique regularmente todos los accesorios y fijaciones para asegurarse de que estén seguros y evitar accidentes. Si falta alguna pieza, está rota, dañada o desgastada, deje de usar el producto hasta que se hayan realizado las reparaciones con piezas autorizadas de fábrica.

Advertencia: No permita que los niños se suban a los muebles, ya que esto puede provocar que se vuelquen y lesiones personales graves. Monte los muebles fuera del alcance de los niños.

Advertencia: No coloque los muebles cerca de fuentes de fuego u objetos de alta temperatura para evitar el riesgo de incendio.

Advertencia: Limpie los muebles con un paño húmedo o alcohol, evite usar agentes de limpieza que contengan químicos corrosivos.

Advertencia: Este producto está equipado con un dispositivo antivuelco. Asegúrese de instalar este dispositivo para evitar lesiones innecesarias causadas por vuelcos.

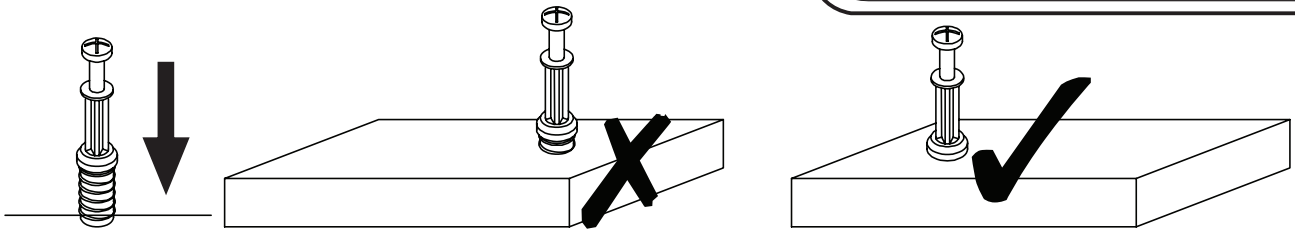

EN_QUICKFIT: Tighten quickfit until shoulder is flush with panel. Do not overtighten or undertighten.

FR_RACCORD RAPIDE: Faites serrer le raccord rapide jusqu'à ce que l'épaulement soit parfaitement encastré dans le panneau. Il ne faut ni trop serrer ni insuffisamment serrer.

ES_QUICKFIT: Apriete quickfit hasta que el hombro se descargue con el panel. NO lo sobreapriete ni lo apriete poco.

DE_QUICKFIT: Ziehen Sie den Quickfit fest, bis die Schulter mit der Platte bündig ist. Bitte nicht zu fest oder zu schwach anziehen.

IT_MONTAGGIO RAPIDO: Stringere il montaggio rapido fino a quando la spalla è a filo con il pannello, non stringere troppo o troppo poco.

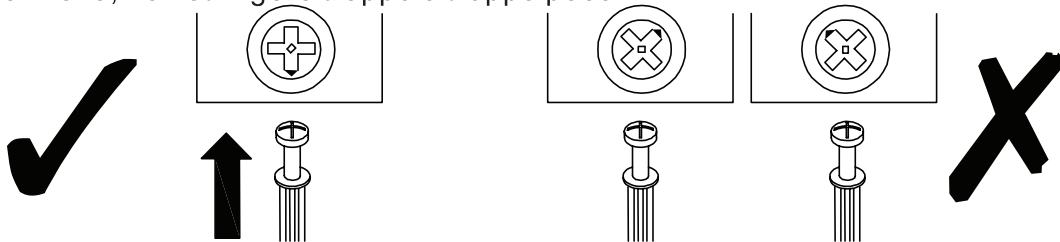

EN_CAM LOCK: When fitting cam lock, ensure starting position is correct before you insert connecting quickfit.

FR_SERRURE BATTEUSE: Avant d'insérer la serrure batteuse, veillez à la bonne orientation avant d'insérer le raccord rapide.

ES_CIERRE DE LA CÁMARA: Cuando instale el cierre de la cámara, asegúrese de que la posición de inicio es correcta antes de que inserte el quickfit conector.

DE_CAM-LOCK: Achten Sie bei der Montage des Cam-Locks auf die richtige Ausgangsposition, bevor Sie den Quickfit einsetzen.

IT_BLOCCAGGIO A CAMMA: Quando si monta il bloccaggio a camma, assicurarsi che la posizione iniziale sia corretta prima di inserire il montaggio rapido di collegamento.

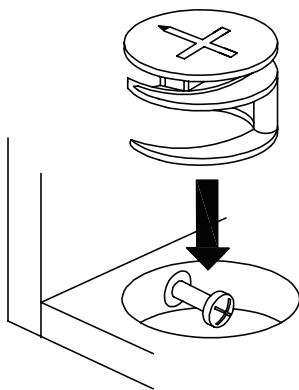

EN_Quickfit head should be in the centre of the cam lock when the two panels are joined.

Cam lock should be inserted before quickfit.

FR_Lorsque les deux panneaux sont assemblés, la tête du raccord rapide doit reposer au centre de la serrure batteuse. Il faut insérer la serrure batteuse avant le raccord rapide.

ES_El cabezal del quickfit debe estar en el centro del cierre de la cámara cuando se unan los dos paneles.

Se debe insertar el cierre de la cámara antes que el quickfit.

DE_Der Quickfit-Kopf sollte sich in der Mitte des Cam-Locks befinden, wenn die beiden Platten zusammengefügt sind. Der Cam-Lock sollte vor dem Quickfit eingesetzt werden.

IT_La testa del montaggio rapido deve trovarsi al centro del bloccaggio a camma quando i due pannelli sono uniti.

Il Bloccaggio a Camma deve essere inserito prima del montaggio rapido.

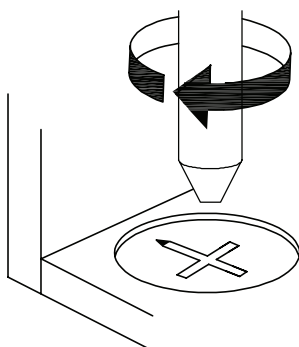

EN_Turn cam lock clockwise to tighten.

FR_Faites tourner la serrure batteuse dans le sens des aiguilles d'une montre pour la resserrer.

ES_Gire el cierre de la cámara en sentido horario para apretarlo.

DE_Drehen Sie den Cam-Lock im Uhrzeigersinn, um ihn festzuziehen.

IT_Ruotare il bloccaggio a camma in senso orario per stringere.

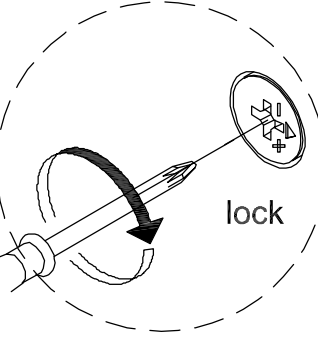
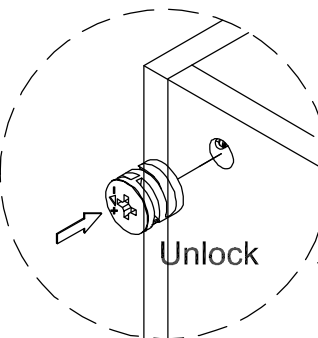
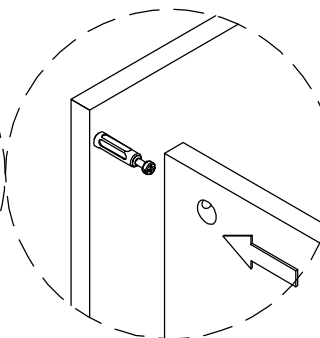
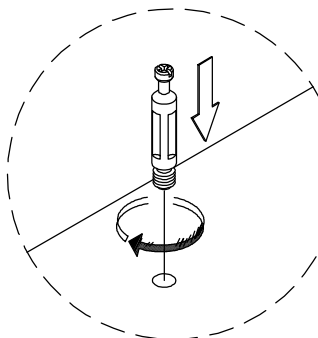
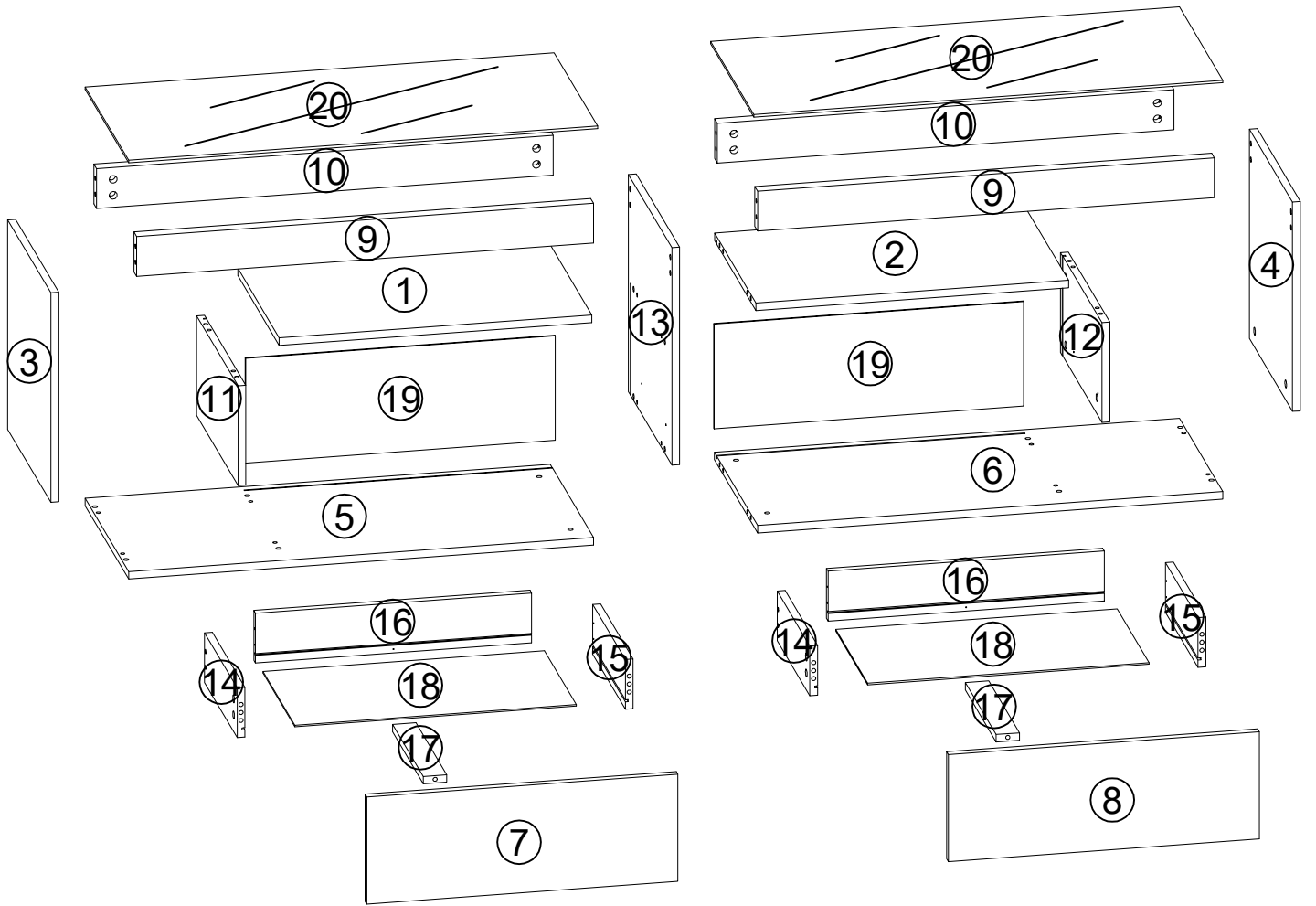

Unlock

lock

SKU N625P283138S

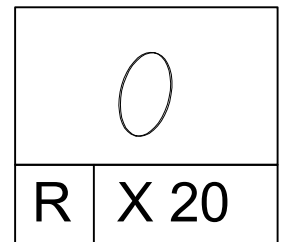
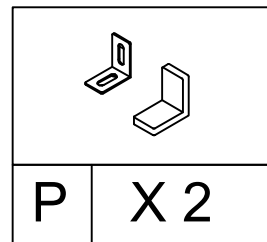
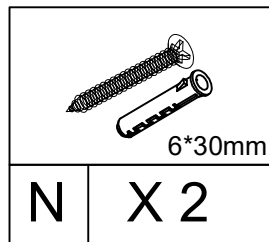
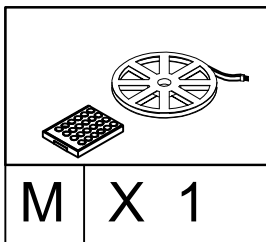
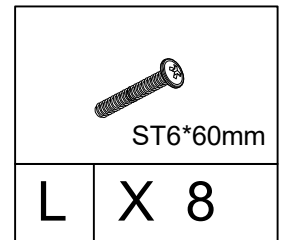
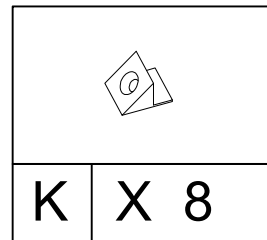
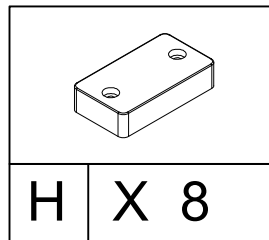
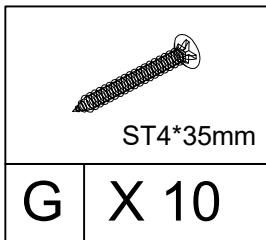
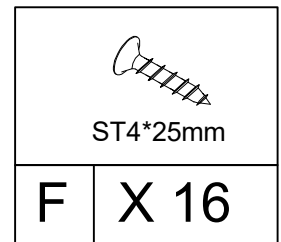
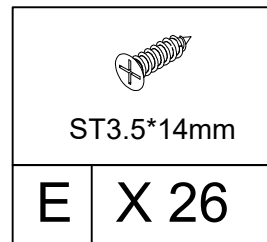
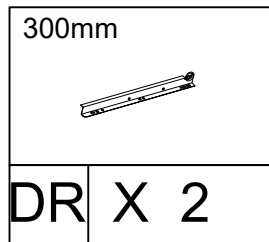
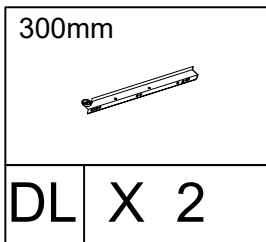
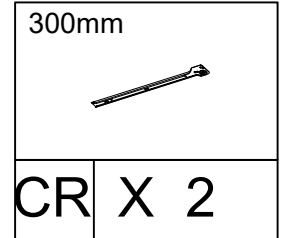
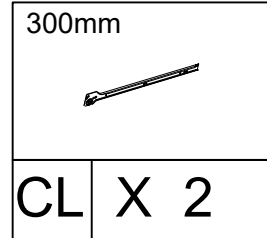
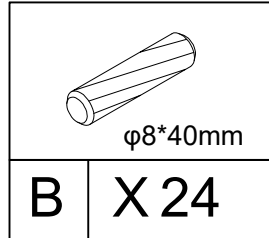
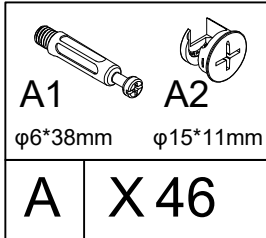

SKU N625P283137S

5

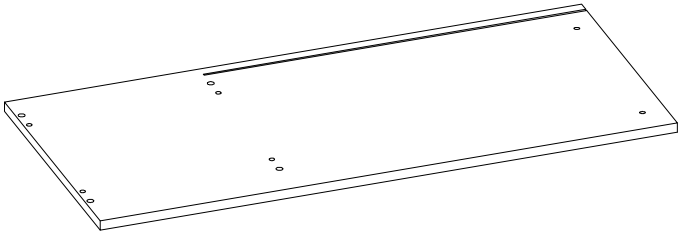

1 PC

6

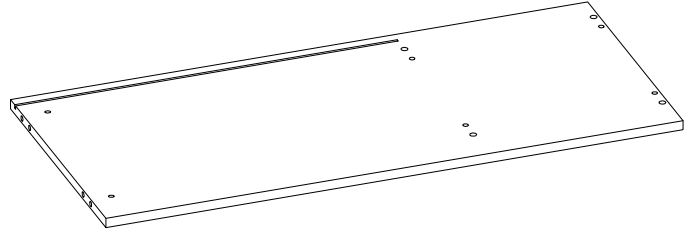

1 PC

9

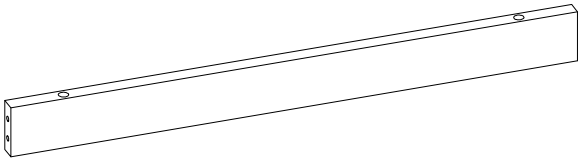

2 PC

10

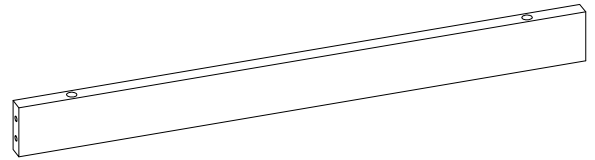

2 PC

17

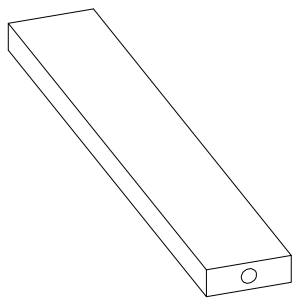

2 PC

20

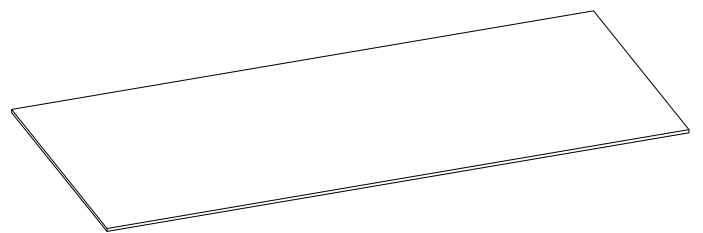

2 PC

SKU N625P283138S

1

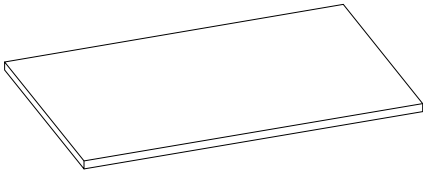

1 PC

2

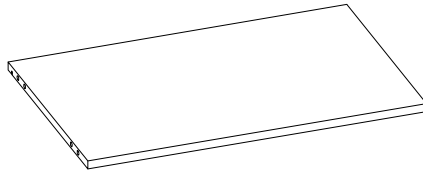

1 PC

3

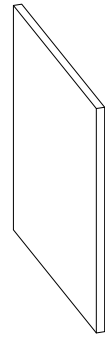

1 PC

4

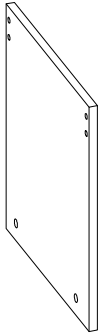

1 PC

7

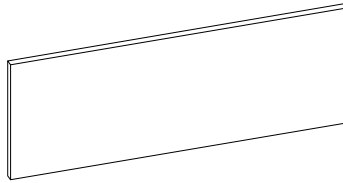

1 PC

8

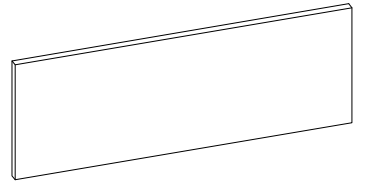

1 PC

11

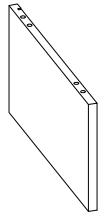

1 PC

12

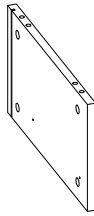

1 PC

13

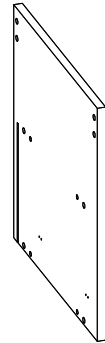

1 PC

14

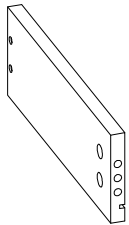

2 PC

15

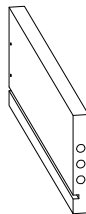

2 PC

16

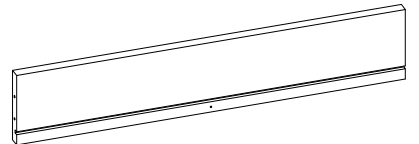

2 PC

18

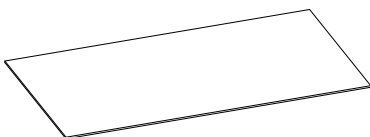

2 PC

19

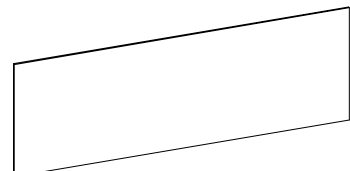

2 PC

1

A1

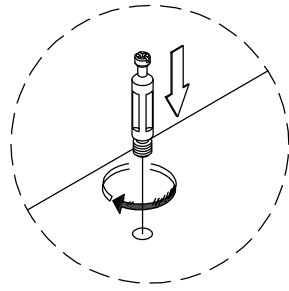
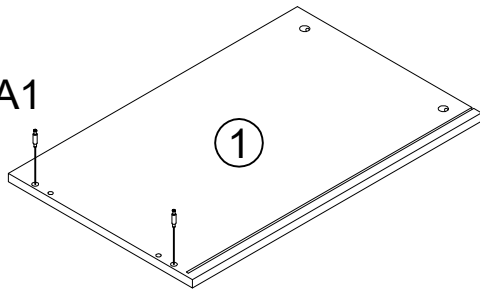

A1

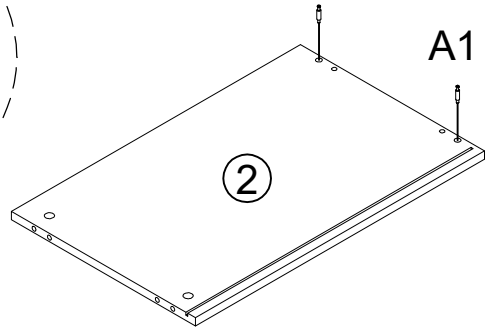

A1

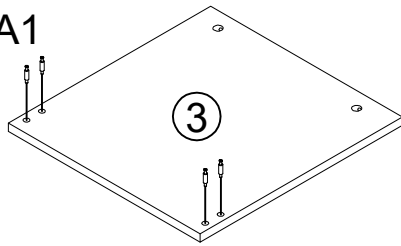

A1

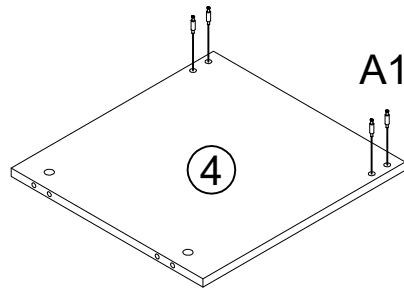

A1

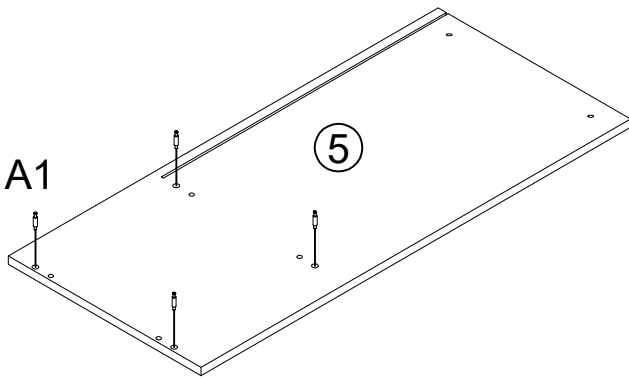

A1

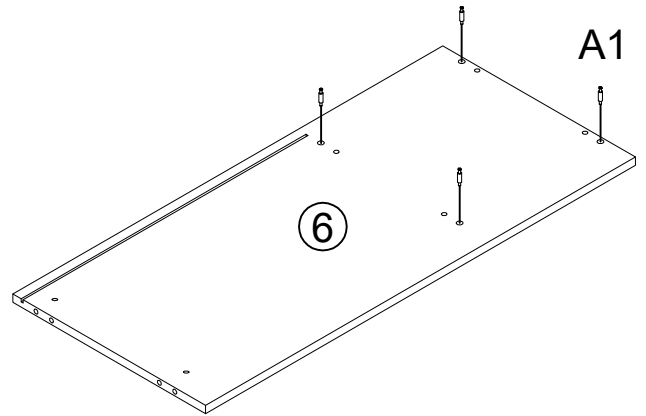

A1

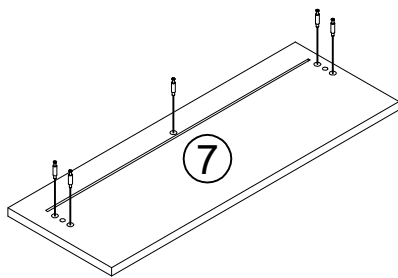

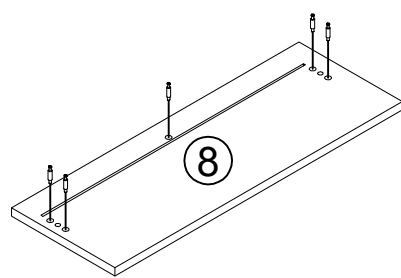

A1

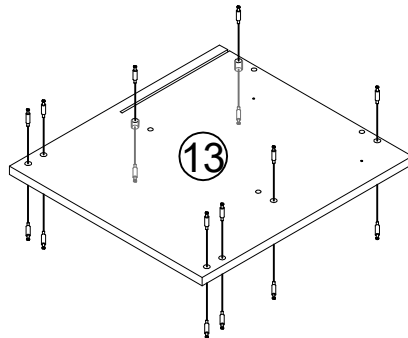

A1

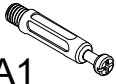

	
A1	A2
$\phi 6 \times 38 \text{mm}$	$\phi 15 \times 11 \text{mm}$
A1	X 46

2

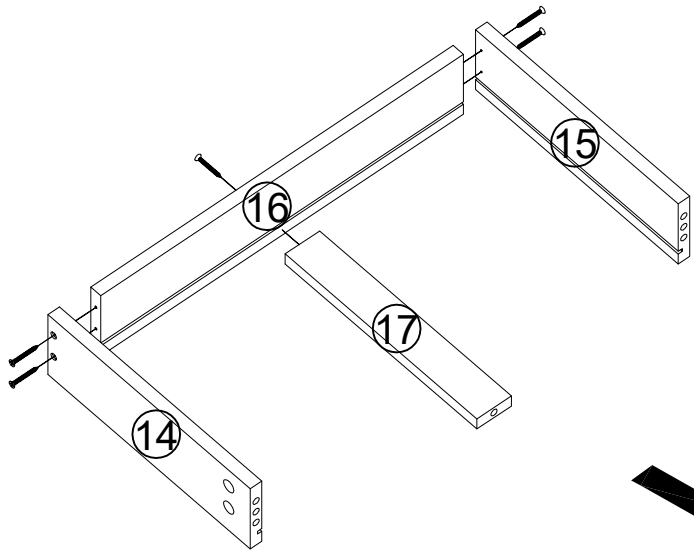
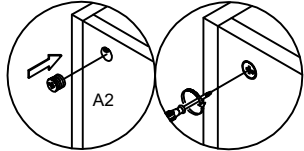

X 2

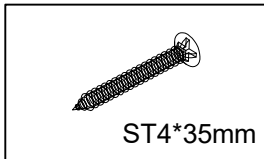
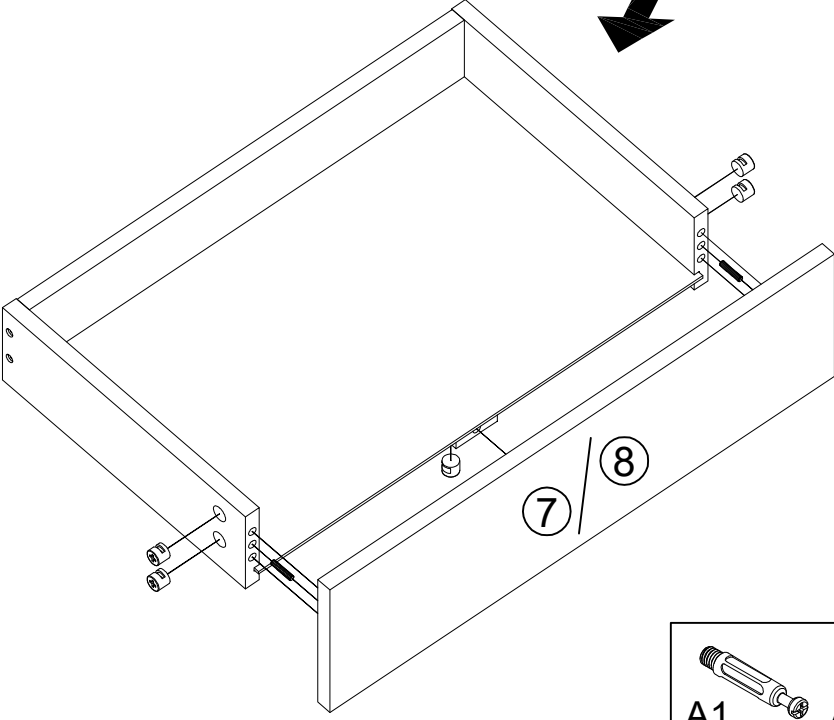
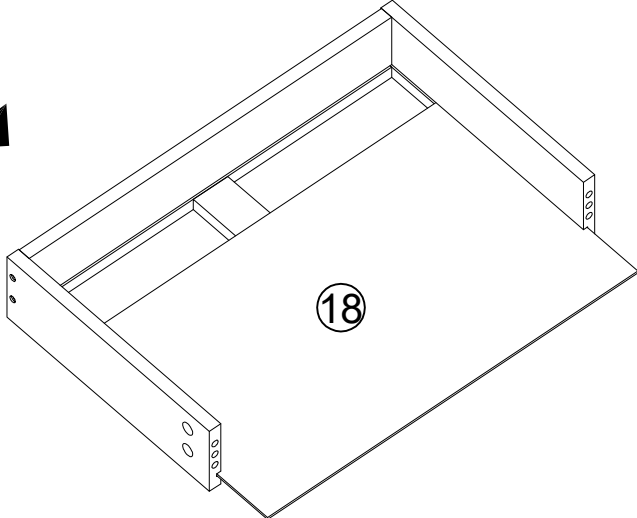

ST4*35mm

G X 10

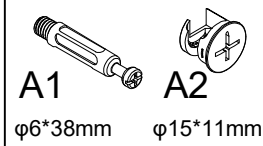

A1
φ6*38mm

A2
φ15*11mm

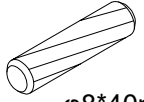





φ8*40mm

A2 X 10

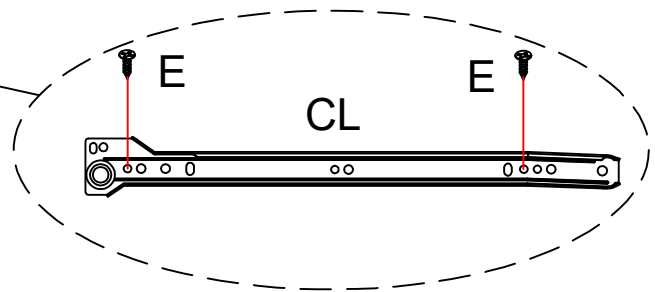
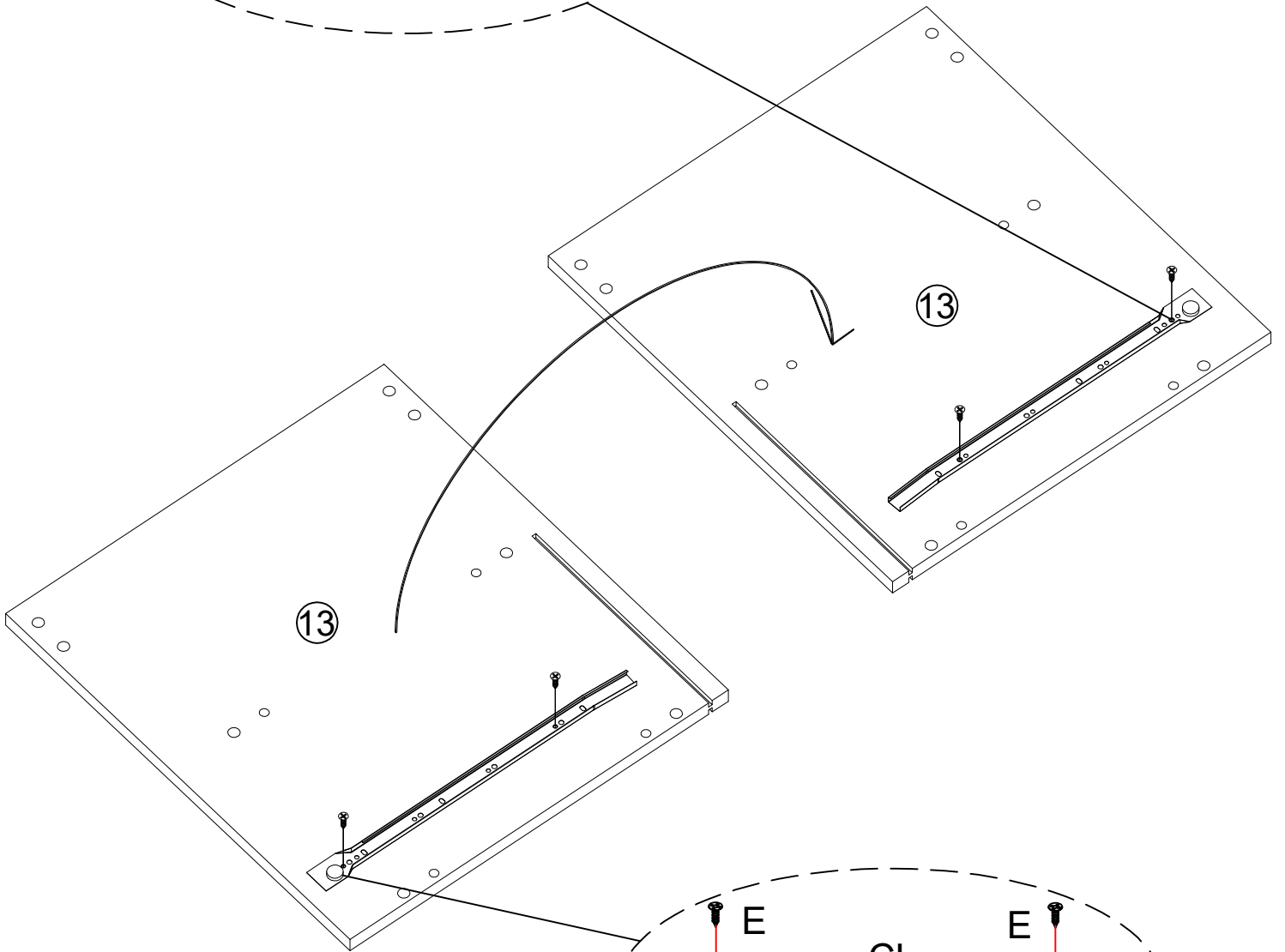
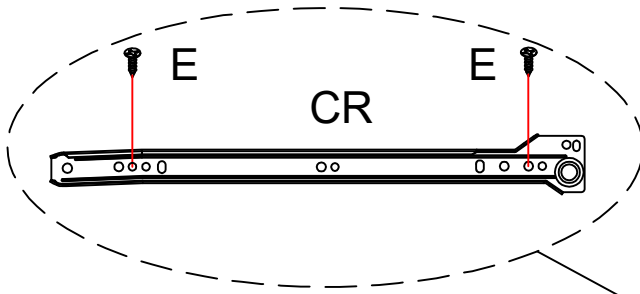
B X 4

3





300mm		300mm		
				ST3.5*14mm
CL	X 1	CR	X 1	E X 4

4

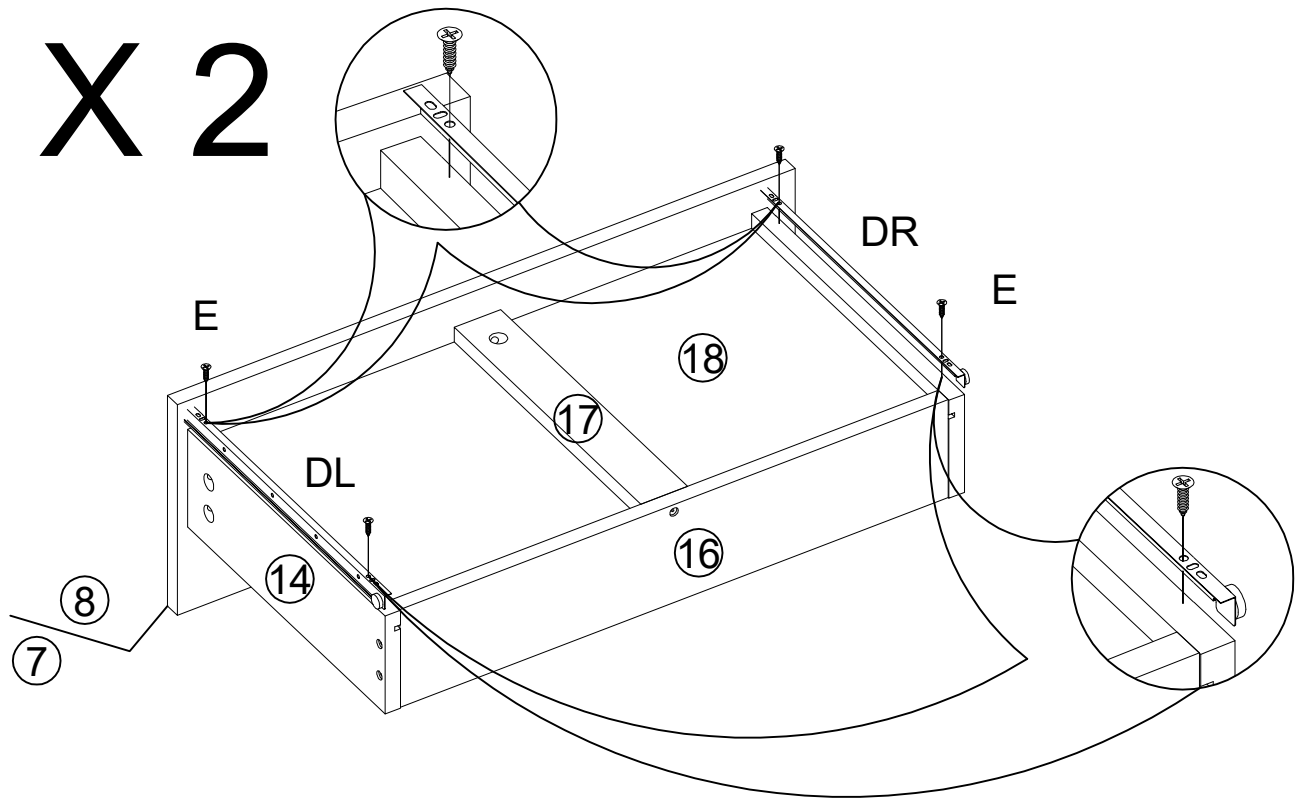

X 2



300mm 		300mm 		 ST3.5*14mm	
DL	X 2	DR	X 2	E	X 8

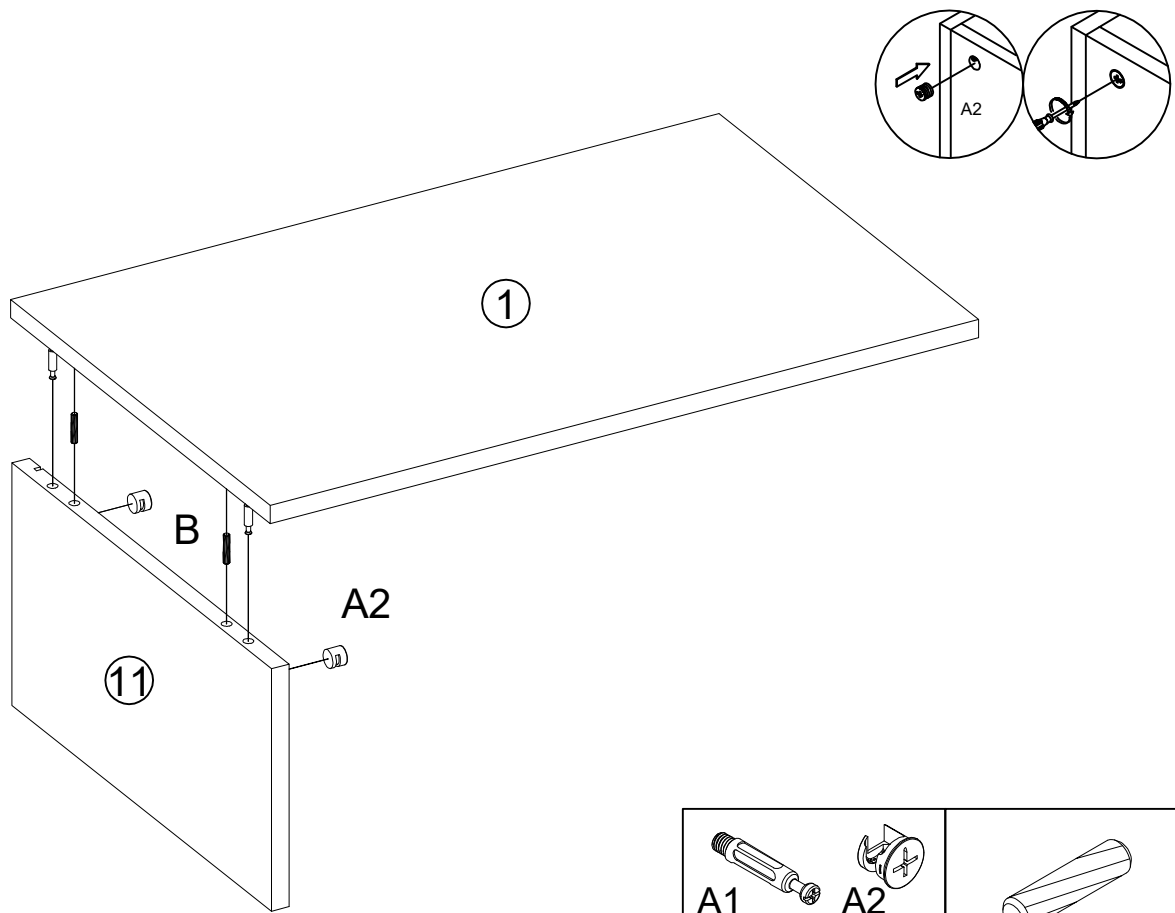

5



 A1 φ6*38mm		 A2 φ15*11mm		 φ8*40mm	
A2	X 2	B	X 2		

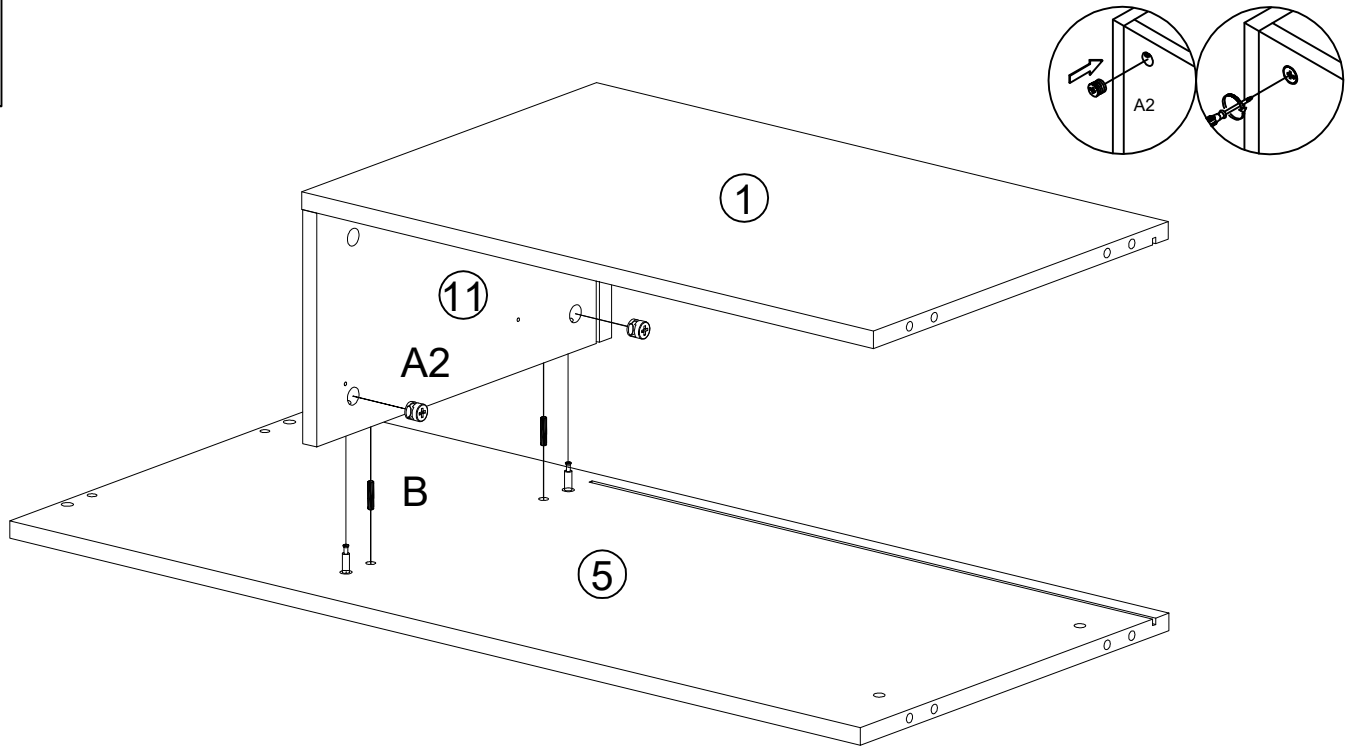

6

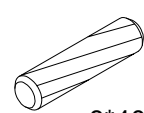

 			
A1 φ6*38mm		A2 φ15*11mm	
A2	X 2	B	X 2

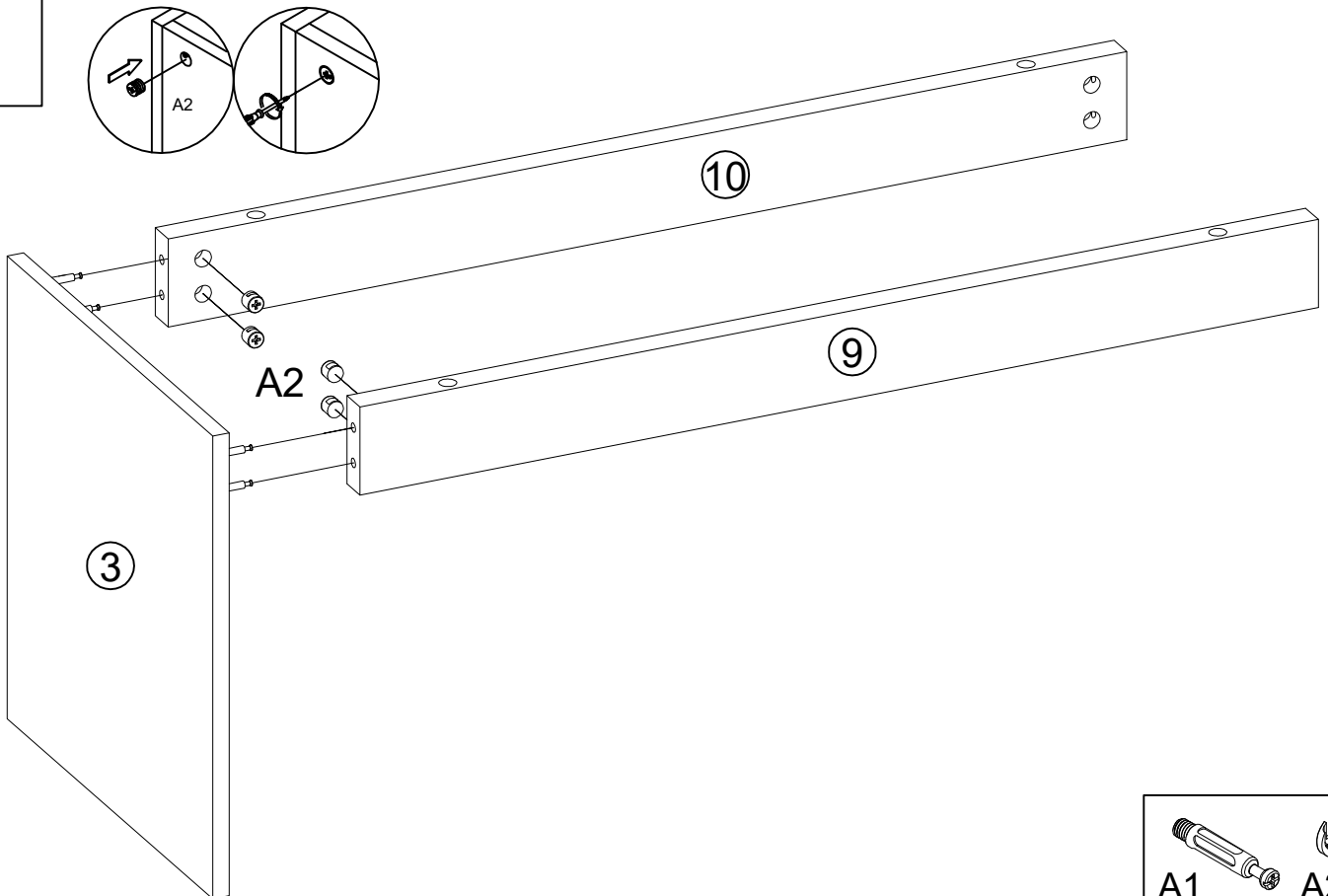

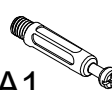
7



 	
A1 φ6*38mm	
A2 φ15*11mm	
A2	X 4

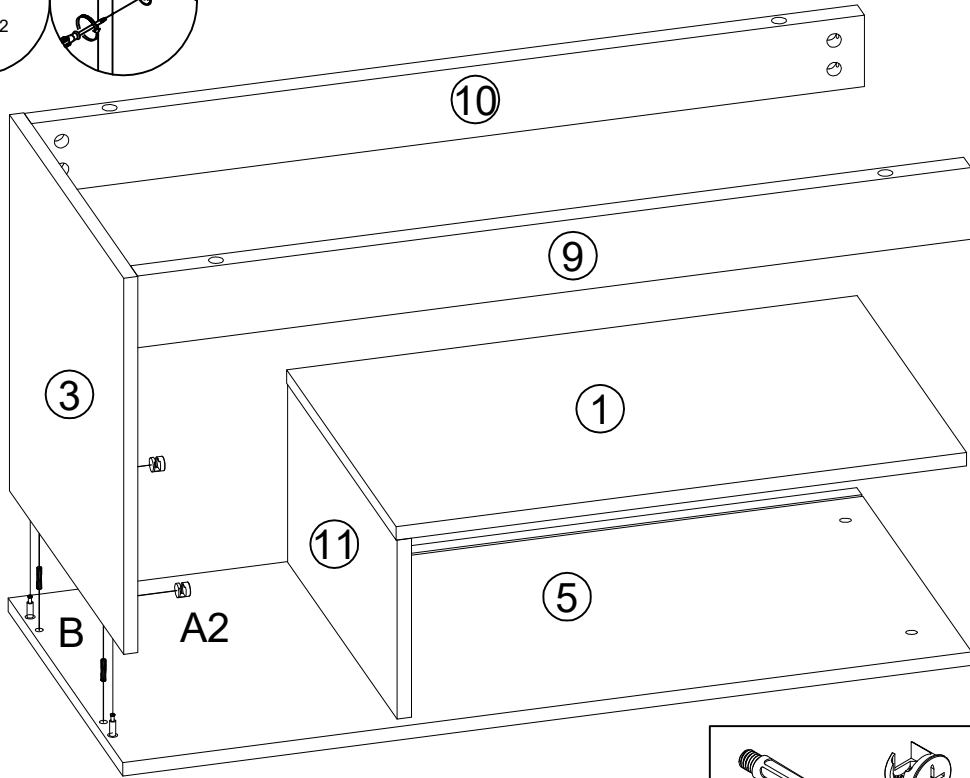
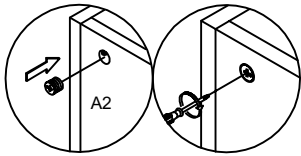

8

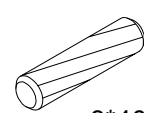

 			
A1 φ6*38mm		A2 φ15*11mm	
A2	X 2	B	X 2

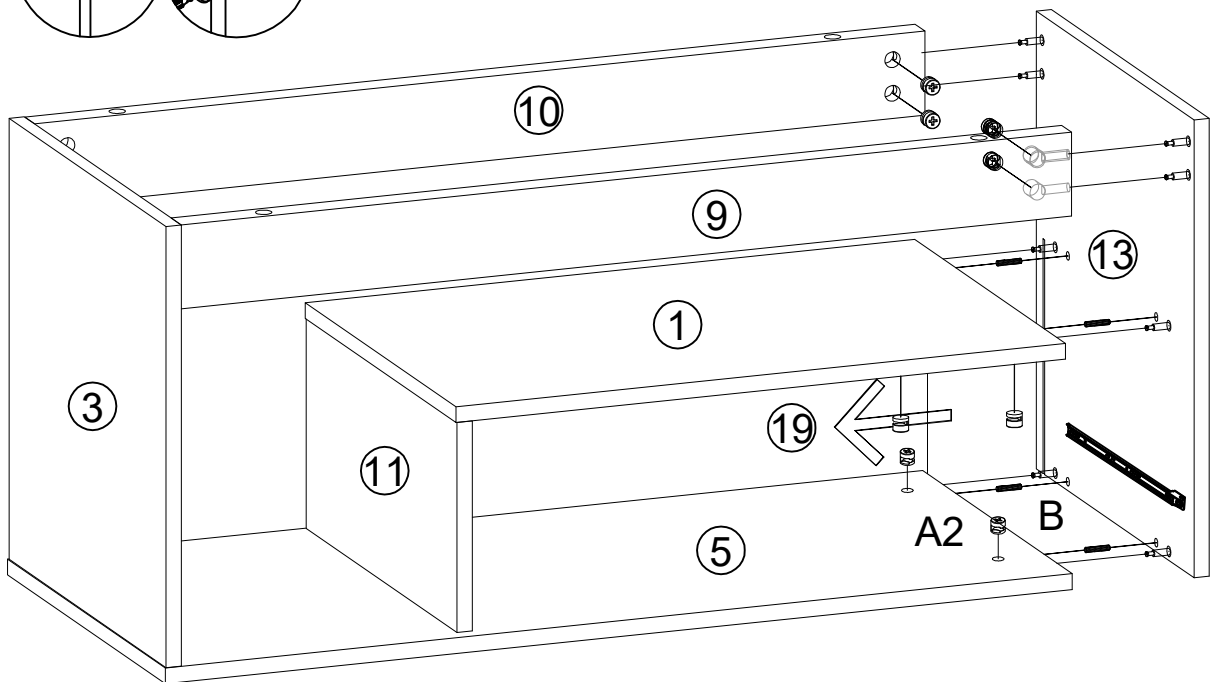
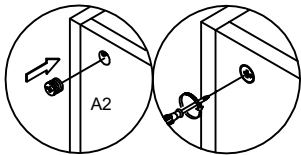

9

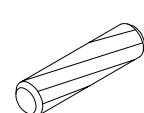

 			
A1 φ6*38mm		A2 φ15*11mm	
A2	X 8	B	X 4

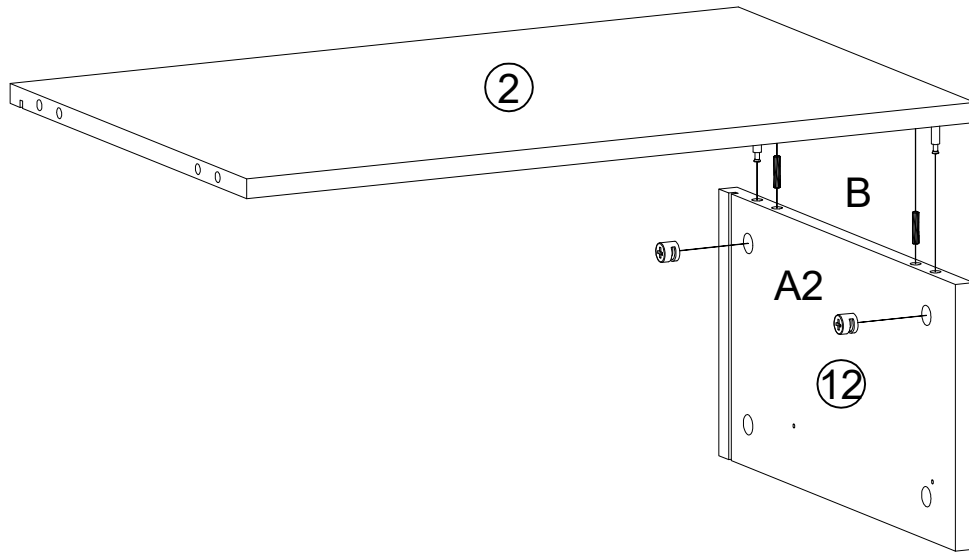
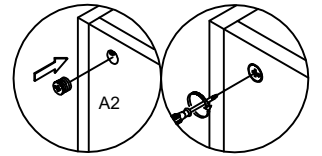

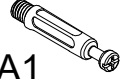
10

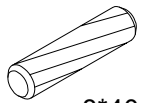

 A1 φ6*38mm	 A2 φ15*11mm	 φ8*40mm
A2	X 2	B X 2

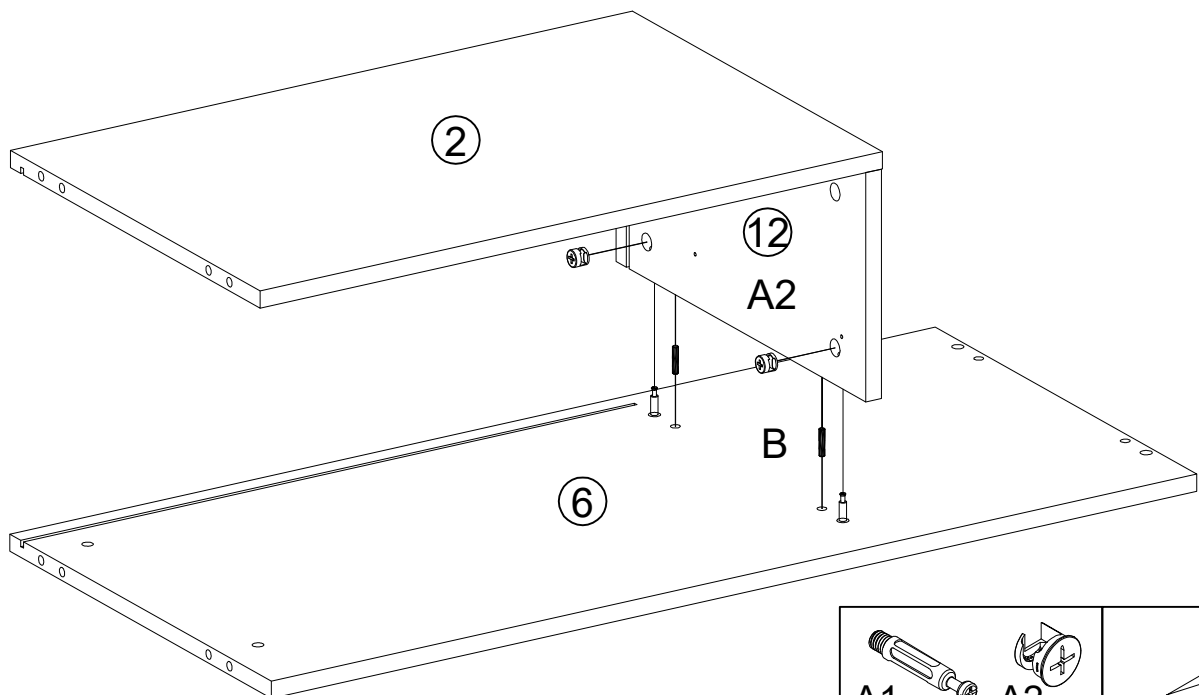
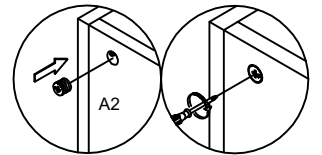
11

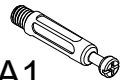

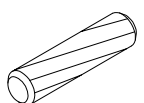
 A1 φ6*38mm	 A2 φ15*11mm	 φ8*40mm
A2	X 2	B X 2

12

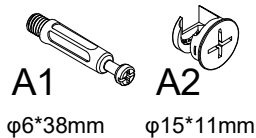
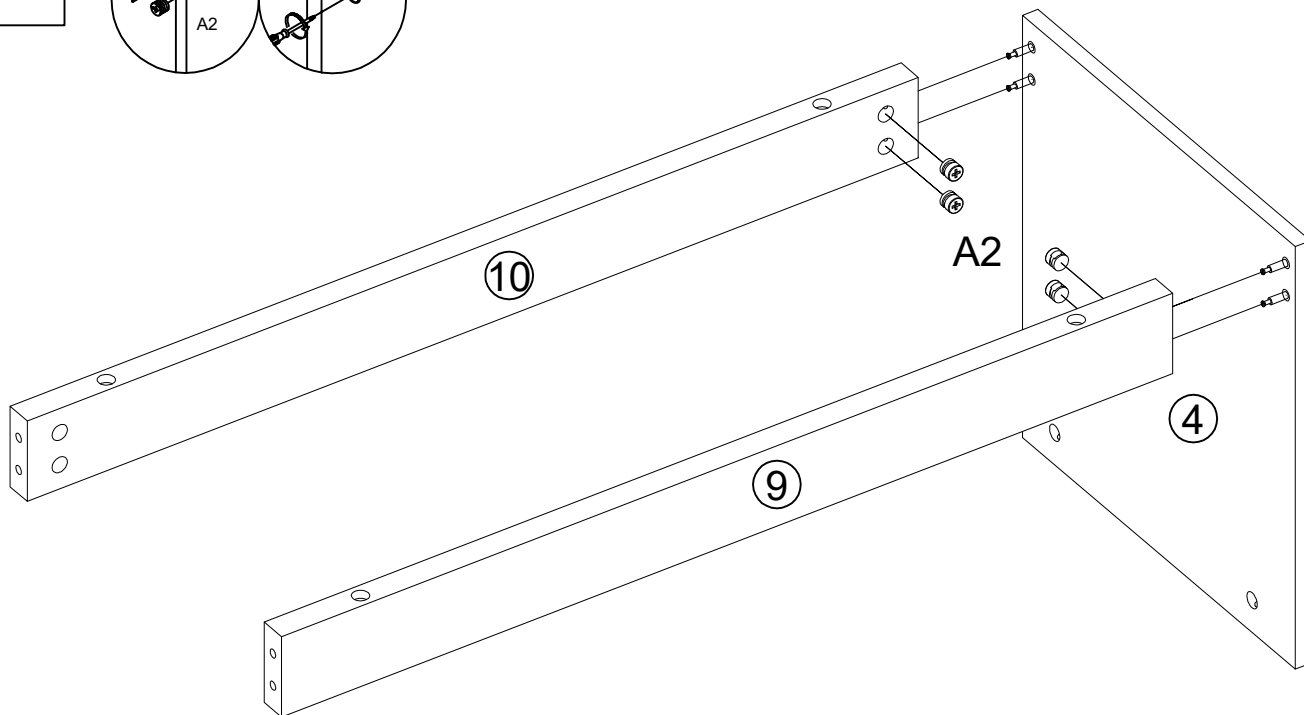
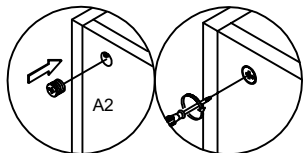

A2	X 4
----	-----

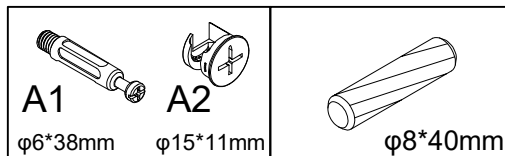
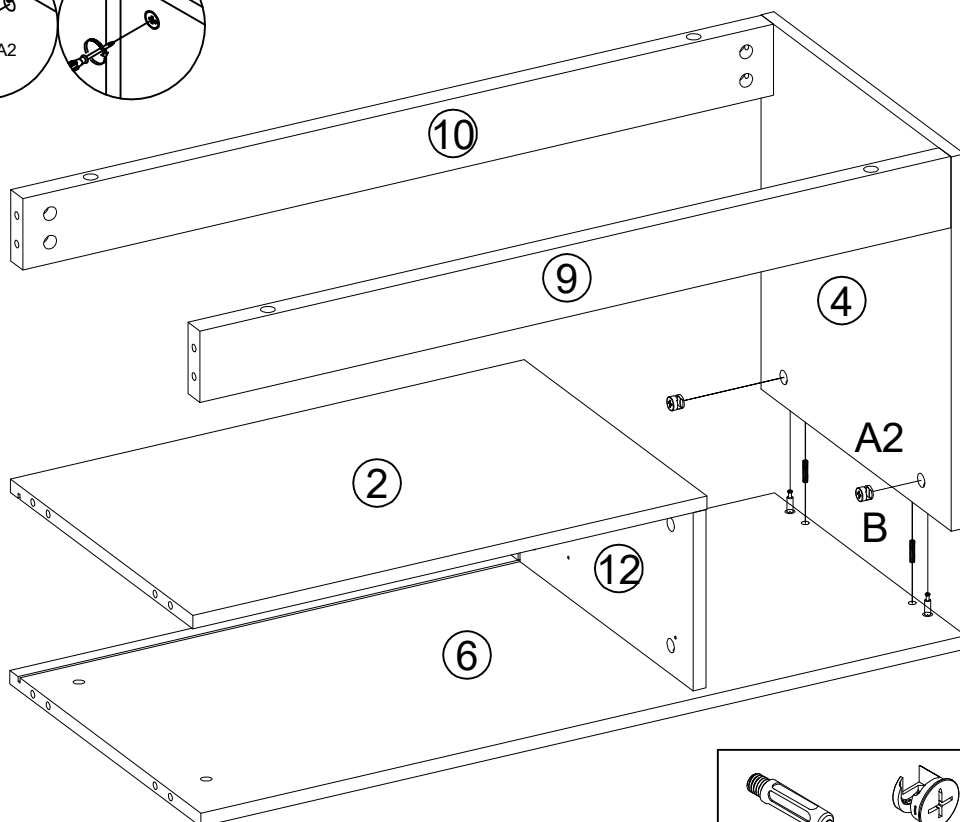
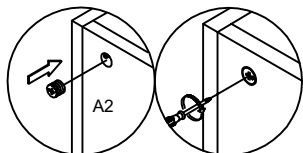

13

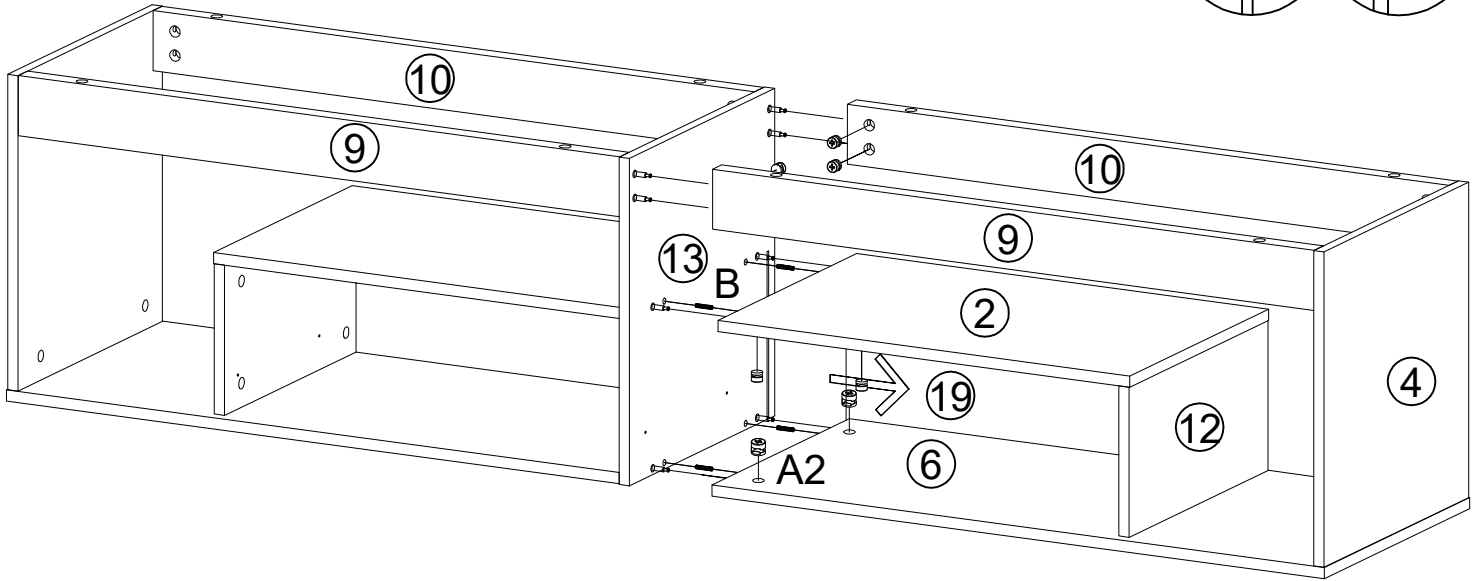
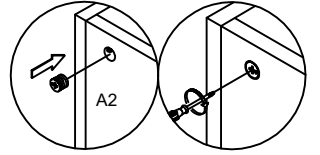

A2	X 2	B	X 2
----	-----	---	-----

14

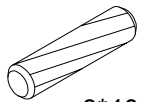

 			
A1 φ6*38mm		A2 φ15*11mm	
A2	X 8	B	X 4

15

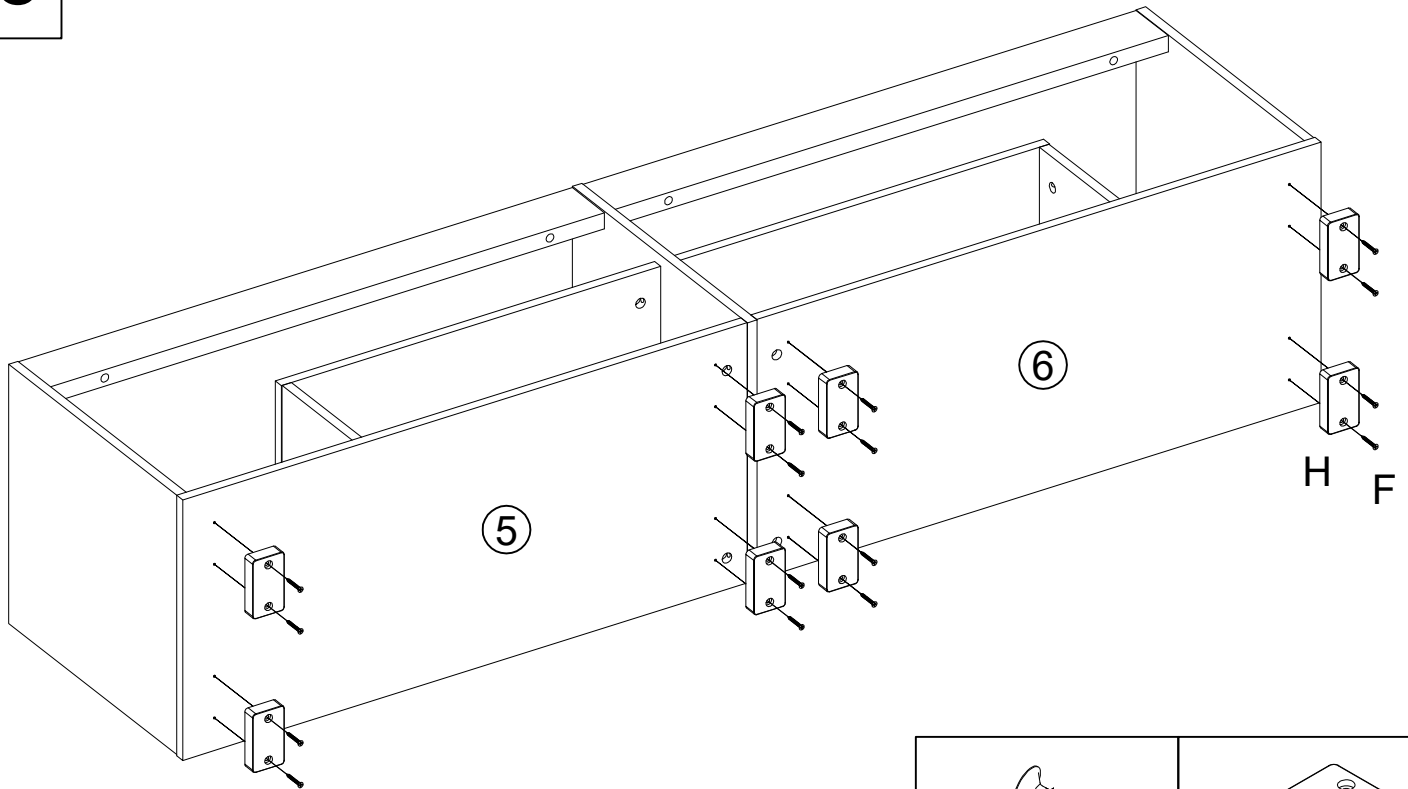

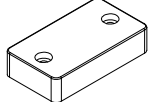
			
ST4*25mm			
F	X 16	H	X 8

16

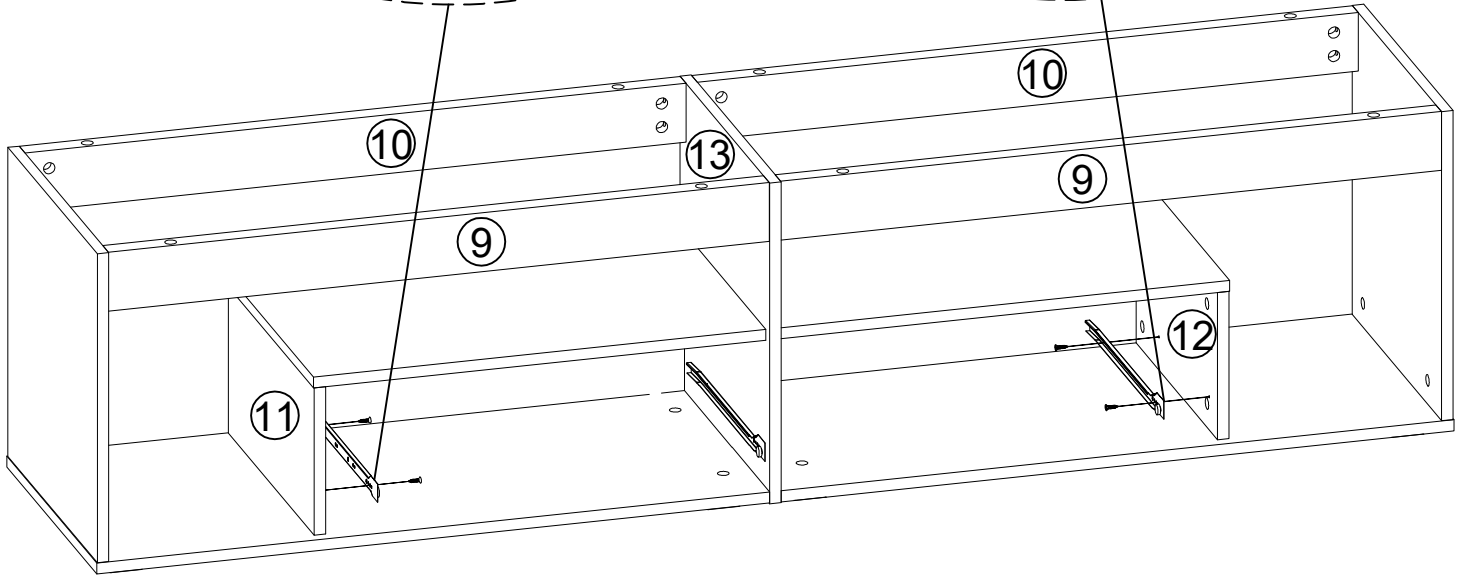
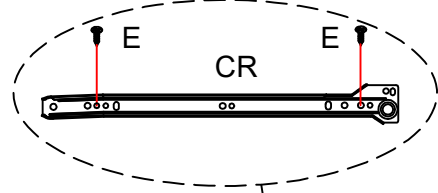
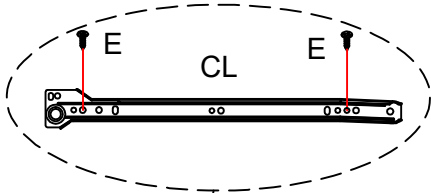

300mm		300mm		 ST3.5*14mm	
CL	X 1	CR	X 1	E	X 4

17

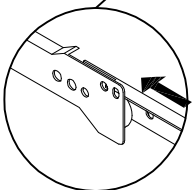
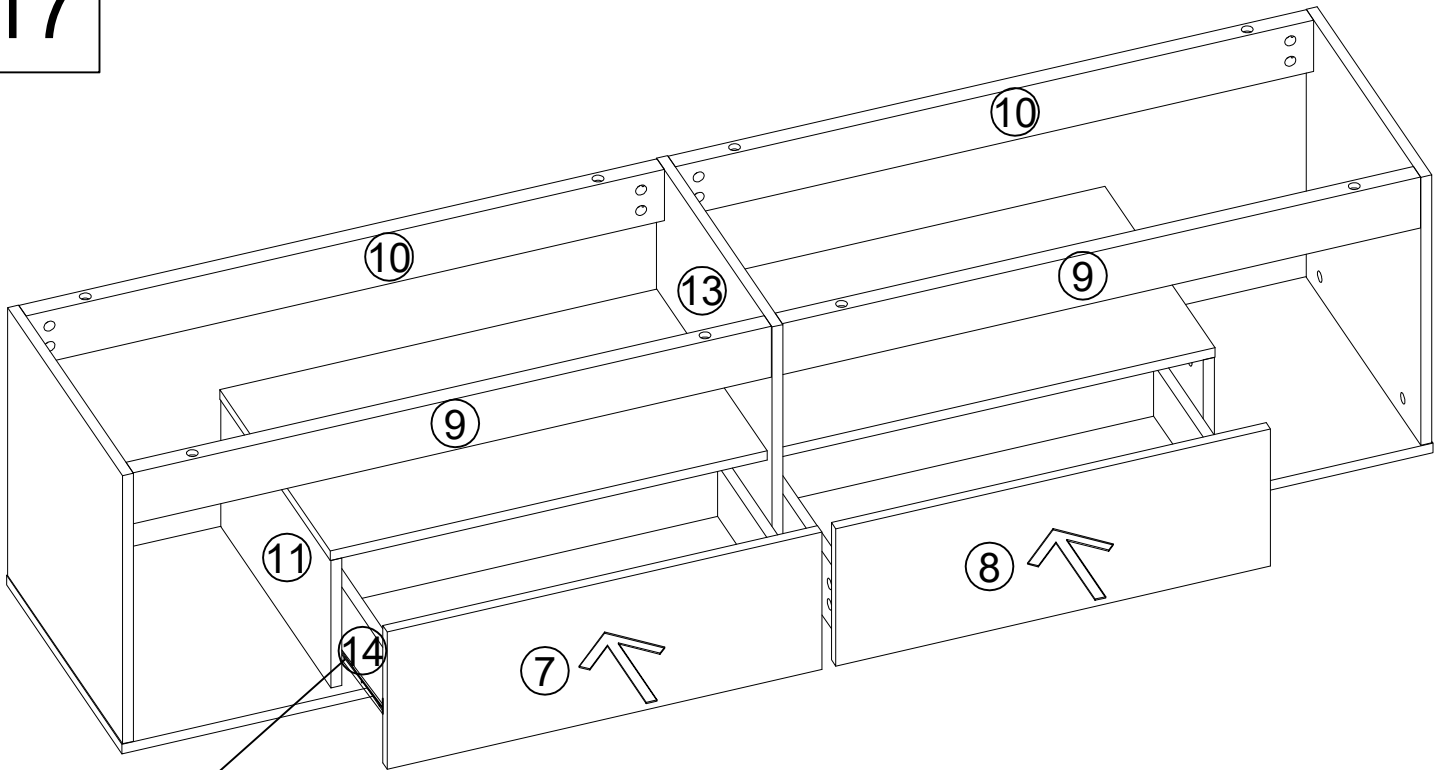

18

DE: Reißen Sie den blauen Aufkleber auf der Rückseite des Lichtstreifens ab und platzieren Sie den LED-Lichtstreifen an der Unterseite der Platine ⑩

EN: Tear off the blue sticker on the back of the light strip and place the LED light strip at the bottom of the board ⑩

FR: Détachez l'autocollant bleu au dos de la bande lumineuse et placez la bande lumineuse LED au bas de la carte ⑩

IT: Staccare l'adesivo blu sul retro della striscia luminosa e posizionare la striscia luminosa a LED nella parte inferiore della scheda ⑩

ES: Quite la etiqueta azul de la parte posterior de la tira de luz y coloque la tira de luz LED en la parte inferior del tablero ⑩

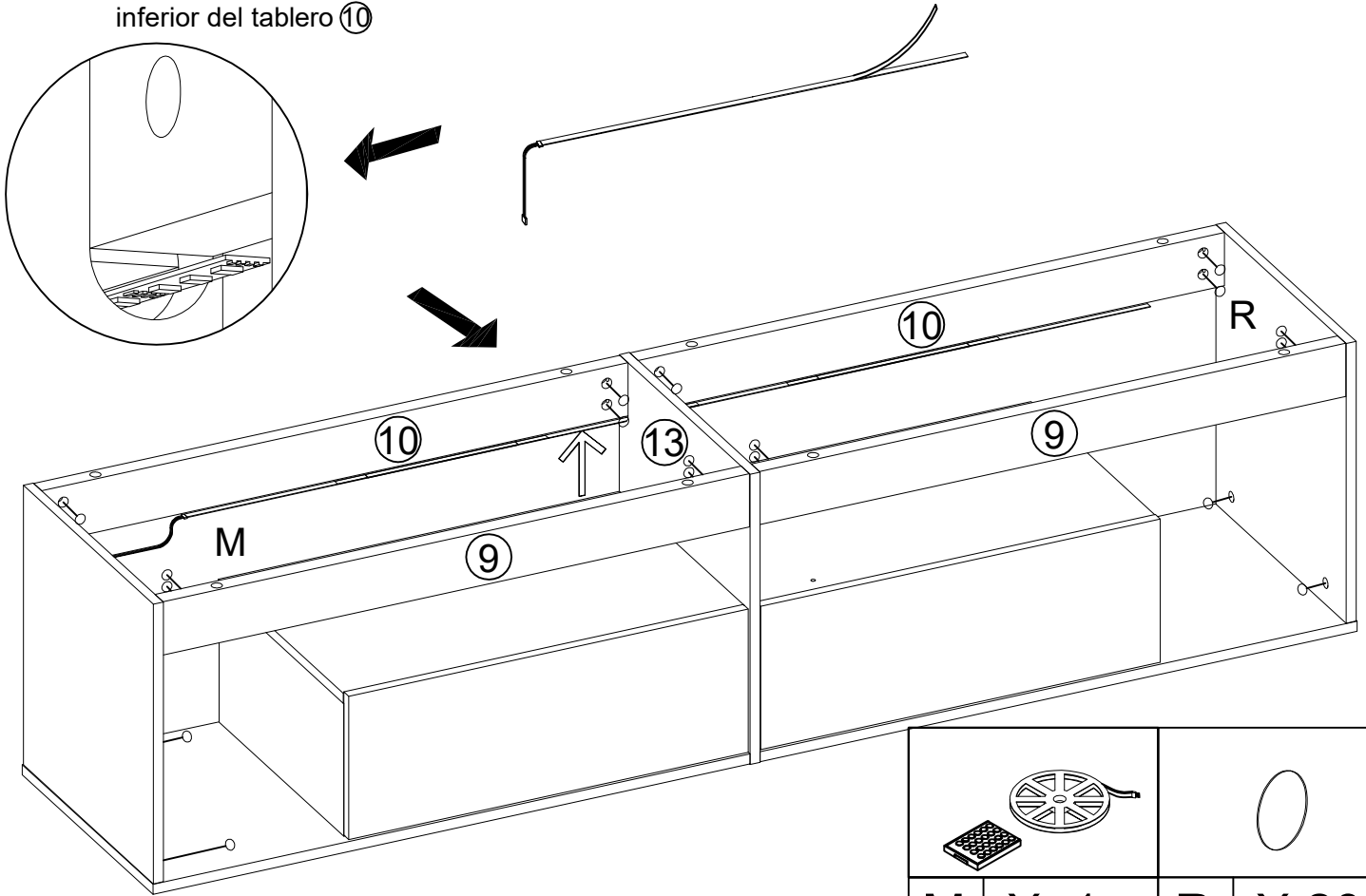

M	X 1	R	X 20

19

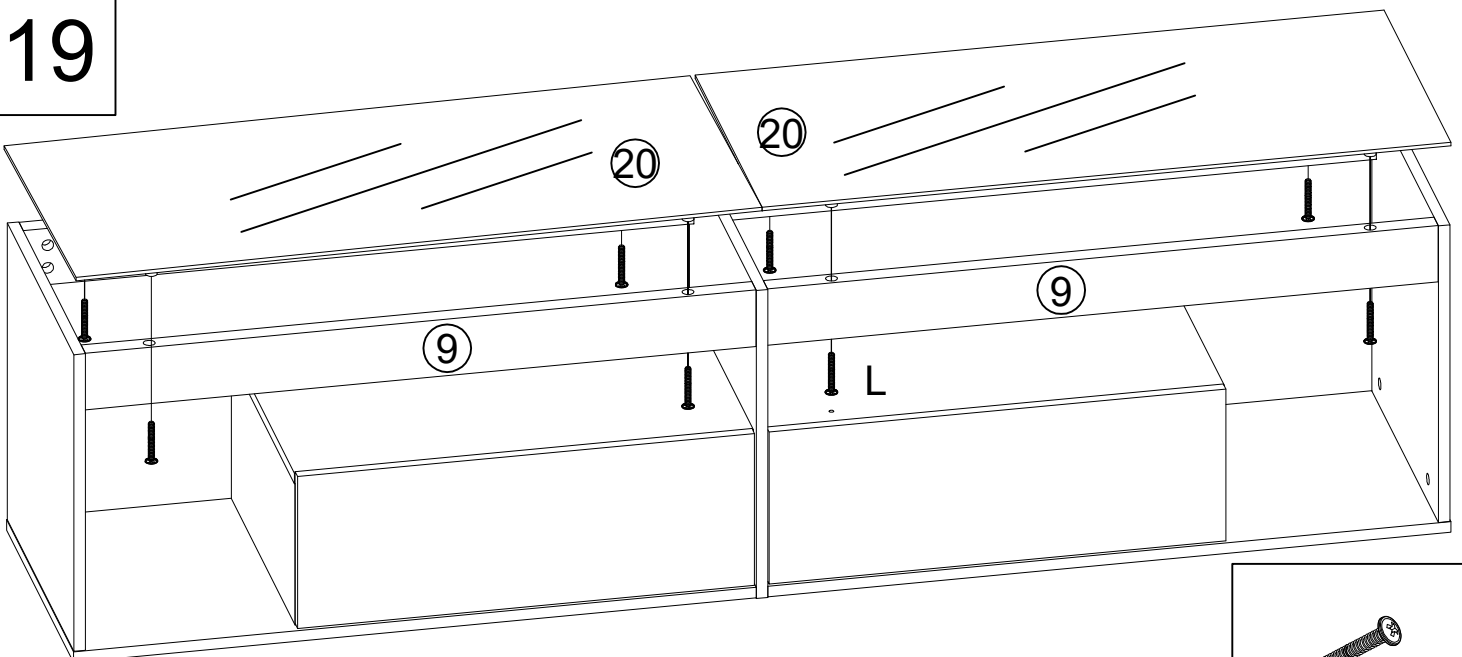



ST6*60mm

L	X 8
---	-----

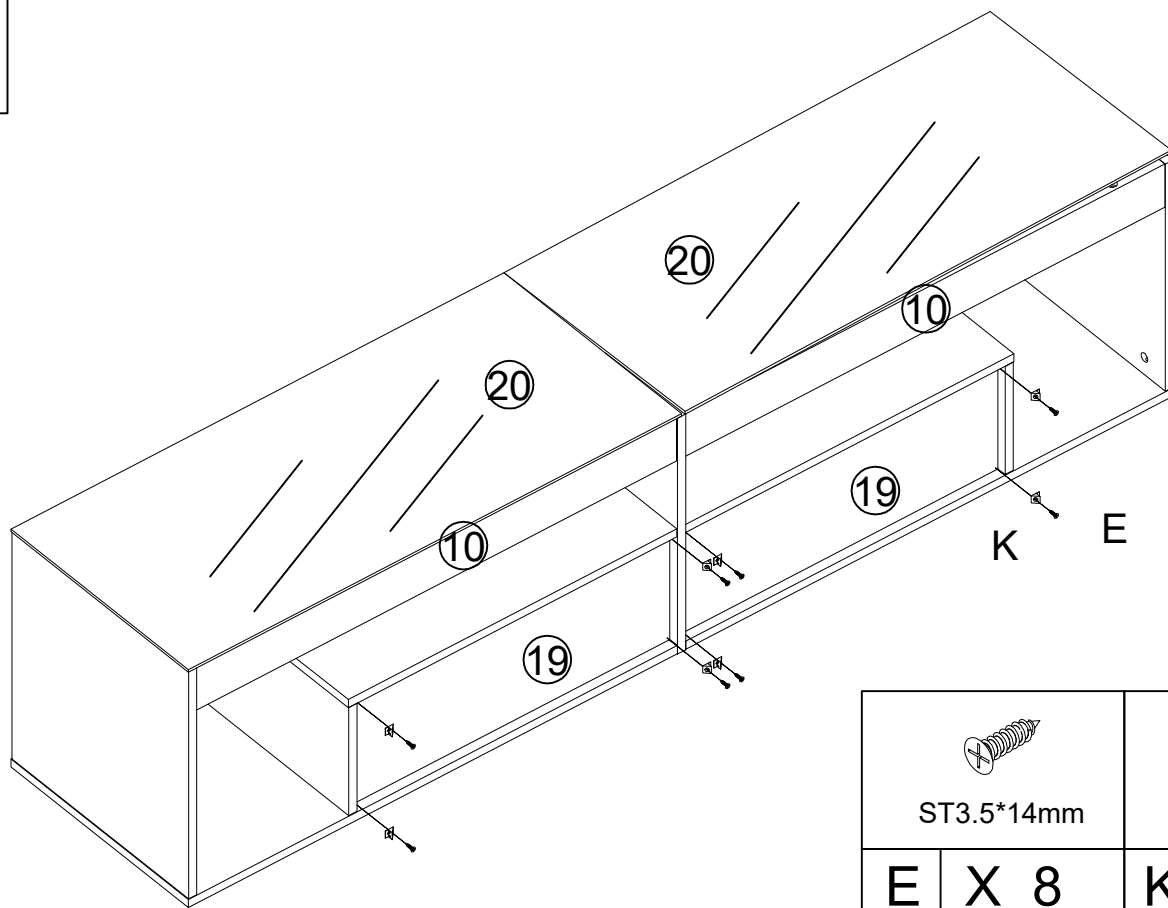
20



 ST3.5*14mm			
E	X 8	K	X 8

21

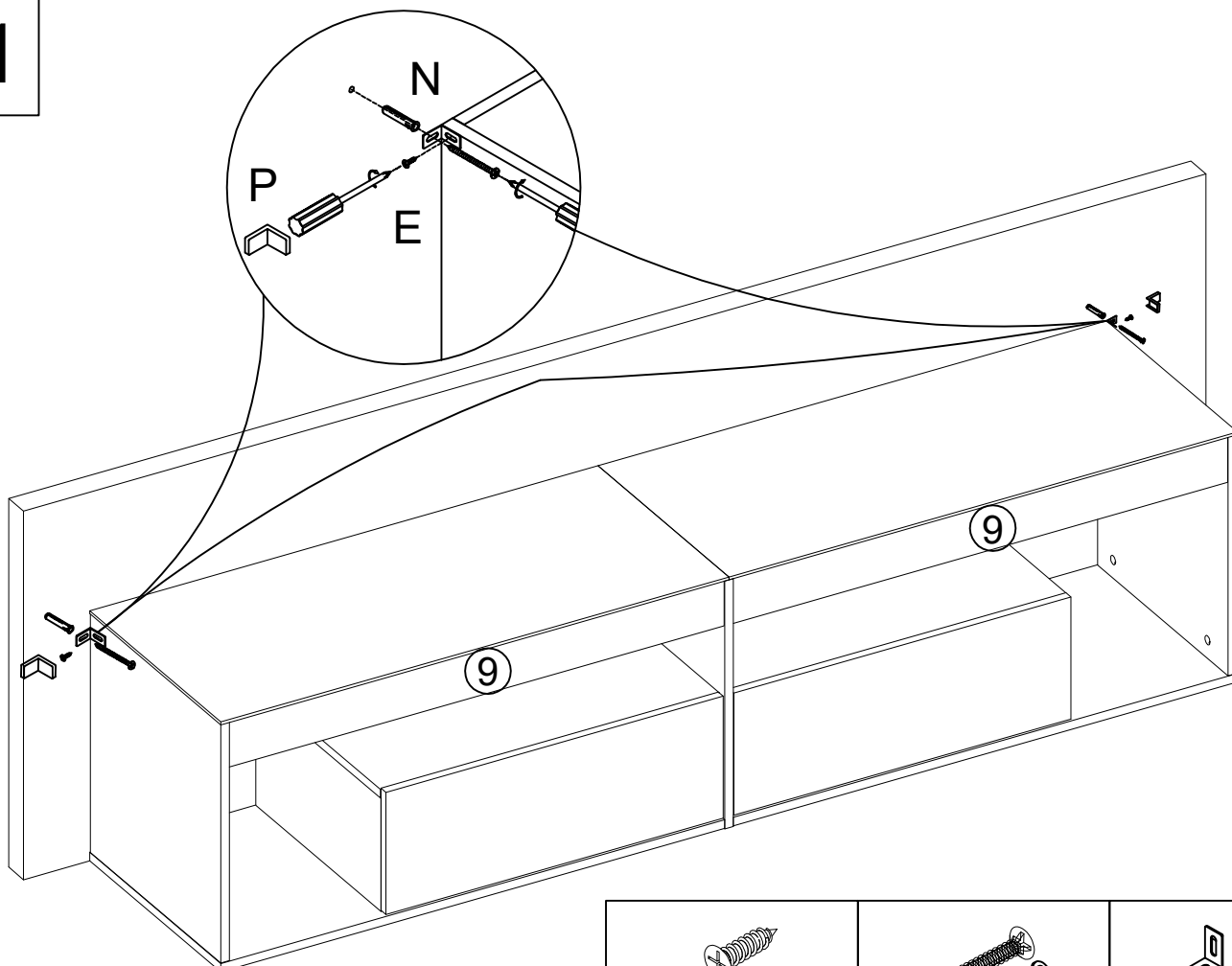

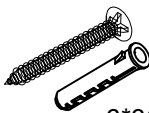
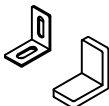
 ST3.5*14mm		 6*30mm			
E	X 2	N	X 2	P	X 2

[DE]

HINWEIS: Der Akku in der Fernbedienung erfordert, dass Sie Sie selbst kaufen und installieren.

Modell: CR2025 3.V

[EN]

NOTE: The battery in the remote control requires you to purchase and install it yourself.

Model: CR2025 3.V

[FR]

REMARQUE : La pile de la télécommande est requise. que vous les achetez et les installez vous-même.

Modèle : CR2025 3.V

[IT]

NOTA: la batteria del telecomando richiede. che li acquisti e li installi tu stesso.

Modello: CR2025 3.V

[ES]

NOTA: La batería del control remoto requiere. que los compre e instale usted mismo.

Modelo: CR2025 3.V



Modell : CR2025 3.V



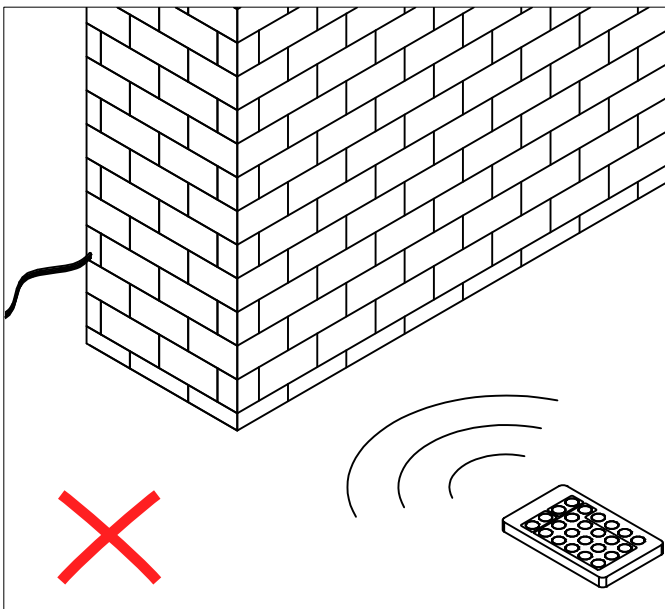
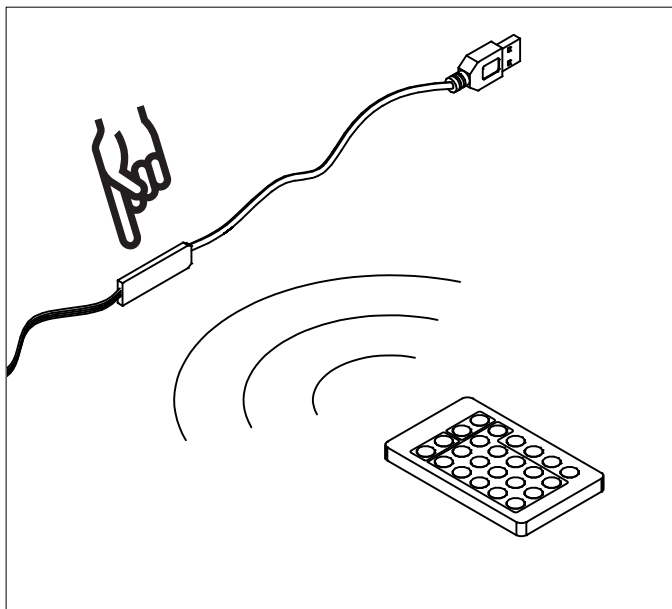

DE (Deutsch):

Wenn Sie das Licht nicht erfolgreich zum Funktionieren bringen können, beachten Sie bitte Folgendes:

1. Stellen Sie sicher, dass die Fernbedienung auf den Empfänger gerichtet ist.
2. Es befinden sich keine Hindernisse zwischen der Fernbedienung und dem Empfänger.
3. Der Abstand zwischen der Fernbedienung und dem Empfänger beträgt weniger als 5 Meter.

EN (English):

If you cannot make the light work successfully, please:

1. Make sure the remote control is pointed at the receiver.
2. There are no obstacles between the remote control and the receiver.
3. The distance between the remote control and the receiver is less than 5 meters.

IT (Italiano):

Se non riesci a far funzionare correttamente la luce, segui questi passaggi:

1. Assicurati che il telecomando sia puntato verso il ricevitore.
2. Non ci sono ostacoli tra il telecomando e il ricevitore.
3. La distanza tra il telecomando e il ricevitore è inferiore a 5 metri.

FR (Français):

Si vous ne parvenez pas à faire fonctionner la lumière correctement, veuillez :

1. Vérifier que la télécommande est dirigée vers le récepteur.
2. S'assurer qu'il n'y a aucun obstacle entre la télécommande et le récepteur.
3. Maintenir une distance entre la télécommande et le récepteur de moins de 5 mètres.

ES (Español):

Si no puede hacer que la luz funcione correctamente, siga estos pasos:

1. Asegúrese de que el control remoto esté apuntando hacia el receptor.
2. No haya obstáculos entre el control remoto y el receptor.
3. La distancia entre el control remoto y el receptor sea inferior a 5 metros.



[DE]

BITTE BEACHTEN: Teilenummer 7 . 8 . 9 ist mit einer dichten Kunststoffschutzfolie überzogen. Wenn das Produkt nach der Demontage Kratzer aufweist, machen Sie sich bitte keine Sorgen, es handelt sich nicht um einen Produktschaden.

Bitte ziehen Sie die schützende Kunststoffolie langsam entlang der Kante von der Oberfläche ab. Nach dem Abziehen wird das Produkt glatt und sauber.

[EN]

PLEASE NOTE: Part number 7 . 8 . 9 are covered with a tight plastic protective film.

If there are scratches on the product after disassembly, please don't worry, it's not product damage. Please slowly tear off the protective plastic film on the surface along the edge. After peeling off, the product becomes smooth and clean.

[FR]

REMARQUE : les pièces numéro 7 . 8 . 9 sont recouvertes d'un film protecteur en plastique étanche.

Si le produit présente des rayures après le démontage, ne vous inquiétez pas, il ne s'agit pas d'un dommage au produit. Retirez lentement le film protecteur en plastique sur la surface le long du bord. Une fois décollé, le produit devient lisse et propre.

[IT]

NOTA BENE: il numero di parte 7 . 8 . 9 è coperto da una pellicola protettiva in plastica stretta.

Se ci sono graffi sul prodotto dopo lo smontaggio, non preoccuparti, non è un danno al prodotto. Strappare lentamente la pellicola protettiva in plastica sulla superficie lungo il bordo. Dopo averla staccata, il prodotto diventa liscio e pulito.

[ES]

NOTA: La pieza número 7 . 8 . 9 está cubierta con una película protectora de plástico.

Si hay rayones en el producto después de desmontarlo, no se preocupe, no se trata de daños en el producto . Retire lentamente la película protectora de plástico de la superficie a lo largo del borde. Después de despegarla, el producto quedará liso y limpio.



Product Service

Attestation of Conformity

No. N8A 120613 0002 Rev. 00

Holder of Attestation: **DONGGUAN BAIYOU ELECTRONIC CO.,LTD**

2F A Building Wufeng Industrial, Jintan Road, Shijie Town
523290 Dongguan City
PEOPLE'S REPUBLIC OF CHINA

Product: **Multiple Socket Outlets**

This Attestation of Conformity is issued on a voluntary basis according to the Low Voltage Directive 2014/35/EU relating to electrical equipment designed for use within certain voltage limits. It confirms that the listed equipment complies with the principal protection requirements of the directive and is based on the technical specifications applicable at the time of issuance. It refers only to the particular sample submitted for conformity assessment. For details see: www.tuvsud.com/ps-cert

Test report no.: 874102337701-00

Date, 2023-09-06

(Jie Zhu)

Page 1 of 3

This Attestation does not replace the regulatory EU Declaration of Conformity (DoC) and does not allow for CE marking. After preparation of the necessary documentation and establishing compliance to requirements of all applicable directives, the manufacturer may sign a DoC and apply the CE marking. The DoC is issued under the sole responsibility of the manufacturer.



TUV®



Product Service

Attestation of Conformity

No. N8A 120613 0002 Rev. 00

Model(s): BY213-G011Y, BY213-G011Y-C,
BY213-G021Y, BY213-G021Y-C,
BY213-G031Y, BY213-G031Y-C,
BY213-G041Y, BY213-G041Y-C

Parameters:

Rated voltage: 250V~
Rated frequency: 50Hz
Rated current: 16A
Protection class: I
Degree of protection: IP20
Type of cable: H05VV-F 3G1.0mm² or H05VV-F 3G1.5mm²
Remark: For BY213-G011Y, BY213-G021Y,
BY213-G031Y, BY213-G041Y:
USB rated output voltage:5.0VDC
USB rated output current:
Single Type A: 2.1A max
Type A + Type A: 2.1A max

For BY213-G011Y-C, BY213-G021Y-C,
BY213-G031Y-C, BY213-G041Y-C:
USB rated output voltage:5.0VDC
USB rated output current:
Single Type A: 3.0A max
Single Type C: 3.0A max
Type A + Type C: 3.1A max
USB rated output voltage:9.0VDC
USB rated output current:
Single Type A: 2.0A max
Single Type C: 2.22A max
USB rated output voltage:12.0VDC
USB rated output current:
Single Type A:1.5A max
Single Type C: 1.67A max

Page 2 of 3

This Attestation does not replace the regulatory EU Declaration of Conformity (DoC) and does not allow for CE marking. After preparation of the necessary documentation and establishing compliance to requirements of all applicable directives, the manufacturer may sign a DoC and apply the CE marking. The DoC is issued under the sole responsibility of the manufacturer.



TUV®



Product Service

Attestation of Conformity

No. N8A 120613 0002 Rev. 00

Model	Number of socket-outlets	With two USB ports, type A +type A	With two USB ports, type A +type C
BY213-G011Y	1	Yes	No
BY213-G011Y-C	1	No	Yes
BY213-G021Y	2	Yes	No
BY213-G021Y-C	2	No	Yes
BY213-G031Y	3	Yes	No
BY213-G031Y-C	3	No	Yes
BY213-G041Y	4	Yes	No
BY213-G041Y-C	4	No	Yes

Tested according to:

IEC 60884-1:2002
 IEC 60884-1:2002/AMD1:2006
 IEC 60884-1:2002/AMD2:2013
 IEC 60884-2-7:2011
 IEC 60884-2-7:2011/AMD1:2013
 SS 428 08 34:2013/T1:2018

Page 3 of 3

This Attestation does not replace the regulatory EU Declaration of Conformity (DoC) and does not allow for CE marking. After preparation of the necessary documentation and establishing compliance to requirements of all applicable directives, the manufacturer may sign a DoC and apply the CE marking. The DoC is issued under the sole responsibility of the manufacturer.



TUV®