



## IMPORTANT !!

SAVE ALL PACKAGING MATERIALS UNTIL PRODUCT IS FULLY ASSEMBLED. HARDWARE AND SMALL PIECES MAY NOT BE SEEN AND BE ACCIDENTLY DISCARDED WITH PACKAGING MATERIALS.

A COUNTRY OF ORIGIN STICKER SHOULD BE IN AN INCONSPICUOUS PLACE SOMEWHERE ON THE PRODUCT. IF THIS STICKER IS IN A CONSPICUOUS PLACE, IT CAN BE MOVED TO AN INCONSPICUOUS PLACE BUT DO NOT DISCARD DUE TO DATE CODE ON STICKER.

PLEASE DO NOT FULLY TIGHTEN THE SCREWS BEFORE THE ITEM IS FULLY ASSEMBLED.

# CPSC Warns Against Placing Babies in Adult Beds

From the U.S. Consumer Product Safety Commission Washington, DC. 20207  
*Study finds 64 deaths each year from suffocation and strangulation*

The U.S. Consumer Product Safety Commission (CPSC) is warning parents and caregivers about the dangers of placing babies to sleep in adult beds. According to a CPSC study, placing babies to sleep in adult beds puts them at risk of suffocation or strangulation and is a danger of which many parents and caregivers are unaware. The study revealed an average 64 deaths per year to babies under the age of 2 years placed to sleep in adult beds, including waterbeds and daybeds. A review of incident data from January 1990 to December 1997 linked adult beds to at least 515 baby deaths. Analysis of the deaths revealed four major hazard patterns:

- \* Suffocation associated with the co-sleeping of adult and baby.
- \* Suffocation where an infant becomes entrapped or wedged between the mattress and another object.
- \* Suffocation due to airway obstruction when the baby is face down on a waterbed mattress.
- \* Strangulation in rails or opening on beds that allow a baby's body to pass through while entrapping the head.

CPSC's study is the first to quantify the number of fatalities resulting from the practice of co-sleeping with babies. Of the 515 deaths, 121 were reported to be due to a parent, caregiver or sibling rolling on top of or against the baby while sleeping. More than three-quarters of these deaths occurred to infants younger than three months.

One of the most tragic aspects of these deaths is that they are largely preventable. In many cases, the adult placing the baby on the adult bed was unaware of or underestimated the danger posed. The practice of co-sleeping can result in the adult rolling on top of or next to the baby smothering him or her. Mothers who breast-feed should be alerted to this hazard and should be encouraged to return the baby to the crib after breast-feeding.

The other 394 deaths resulted from suffocation or strangulation caused by entrapment of the child's head in various structures of the bed. Entrapments occurred between the mattress and the wall, bed frame, headboard, footboard, bed railings or adjacent furniture.

"Don't sleep with your baby or put the baby down to sleep in an adult bed," said CPSC Chairman Ann Brown. The only safe place for babies is in a crib that meets current safety standards and has a firm, tight-fitting mattress. Place babies to sleep on their backs and remove all soft bedding and pillow like items from the crib."

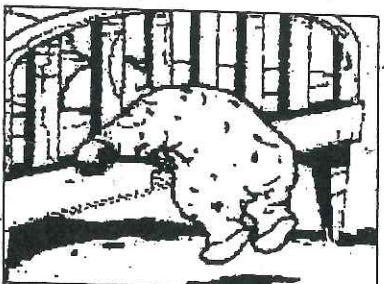
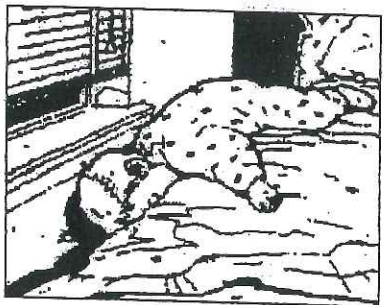
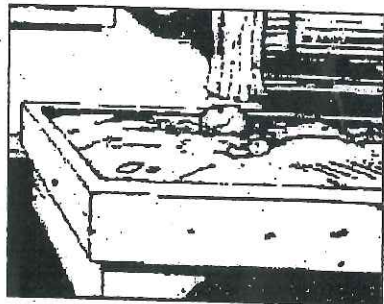

009909

► This information is reproduced from CPSC's web site, August, 2001.

# FASHION BED GROUP®

A  **inka** COMPANY

## Parts List For Benson Bed

### BED CARTONS

#### GRILL BOX

(1) HEADBOARD/FOOTBOARD GRILL-(2)

PART #397601 HARDWARE BAG FOR BED FRAME ATTACHMENT

- (2) 6MM X 80MM FLAT ALLEN HEAD SCREW-8
- (3) 6MM ID FLAT METAL WASHER-16
- (4) 6MM HEX NUT-8
- (5) ALLEN WRENCH-1

#### POST BOX

(6) HEADBOARD POST-2  
(7) FOOTBOARD POST-2

PART #397602 HARDWARE BAG FOR BED GRILL ASSEMBLY

- (2) 6MM X 80MM FLAT ALLEN HEAD SCREW-4
- (8) 6MM X 20MM FLAT ALLEN HEAD SCREW-4
- (5) ALLEN WRENCH-1

### HEADBOARD CARTONS

#### GRILL BOX

(1) HEADBOARD GRILL (1)

PART #397603 HARDWARE BAG FOR HDBD FRAME ATTACHMENT

- (2) 6MM X 80MM FLAT ALLEN HEAD SCREW-4
- (3) 6MM ID FLAT METAL WASHER-8
- (4) 6MM HEX NUT-4
- (5) ALLEN WRENCH-1

#### POST BOX

(6) HEADBOARD POST-2

PART #397604 HARDWARE BAG FOR HDBD GRILL ASSEMBLY

- (2) 6MM X 80MM FLAT ALLEN HEAD SCREW-2
- (8) 6MM X 20MM FLAT ALLEN HEAD SCREW-2
- (5) ALLEN WRENCH-1

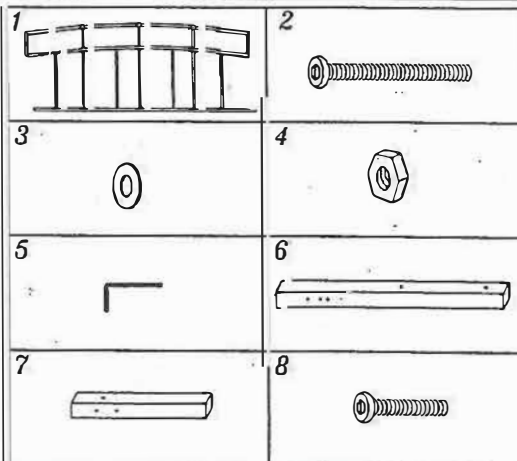

## PRODUCT FULLY ASSEMBLED

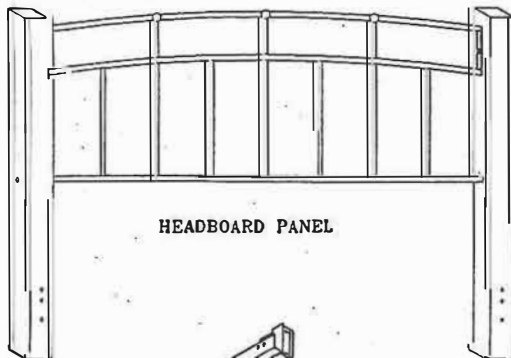

HEADBOARD PANEL

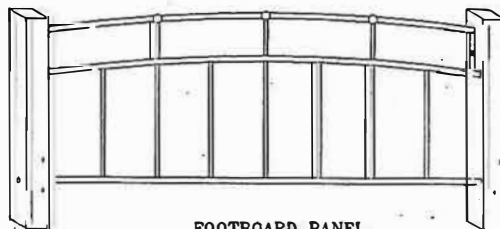

FOOTBOARD PANEL

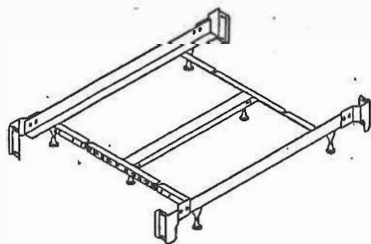

QUEEN - KING BED FRAME FULLY ASSEMBLED

NOTE: SEE INSTRUCTIONS INCLUDED IN FRAME CARTON FOR FRAME ASSEMBLY

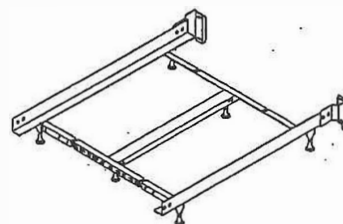

QUEEN - KING HEADBOARD ONLY FRAME FULLY ASSEMBLED

NOTE: SEE INSTRUCTIONS INCLUDED IN FRAME CARTON FOR FRAME ASSEMBLY

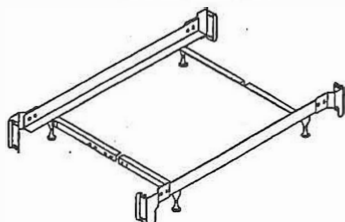

TWIN - FULL BED FRAME FULLY ASSEMBLED

NOTE: SEE INSTRUCTIONS INCLUDED IN FRAME CARTON FOR FRAME ASSEMBLY

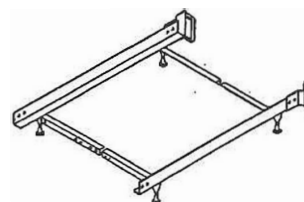

TWIN - FULL HEADBOARD ONLY FRAME FULLY ASSEMBLED

NOTE: SEE INSTRUCTIONS INCLUDED IN FRAME CARTON FOR FRAME ASSEMBLY

# Instruction Sheet

SAVE ALL PACKAGING MATERIALS UNTIL PRODUCT IS FULLY ASSEMBLED. HARDWARE AND SMALL PIECES MAY NOT BE SEEN AND BE ACCIDENTALLY DISCARDED WITH PACKAGING MATERIALS.

FIGURE 1

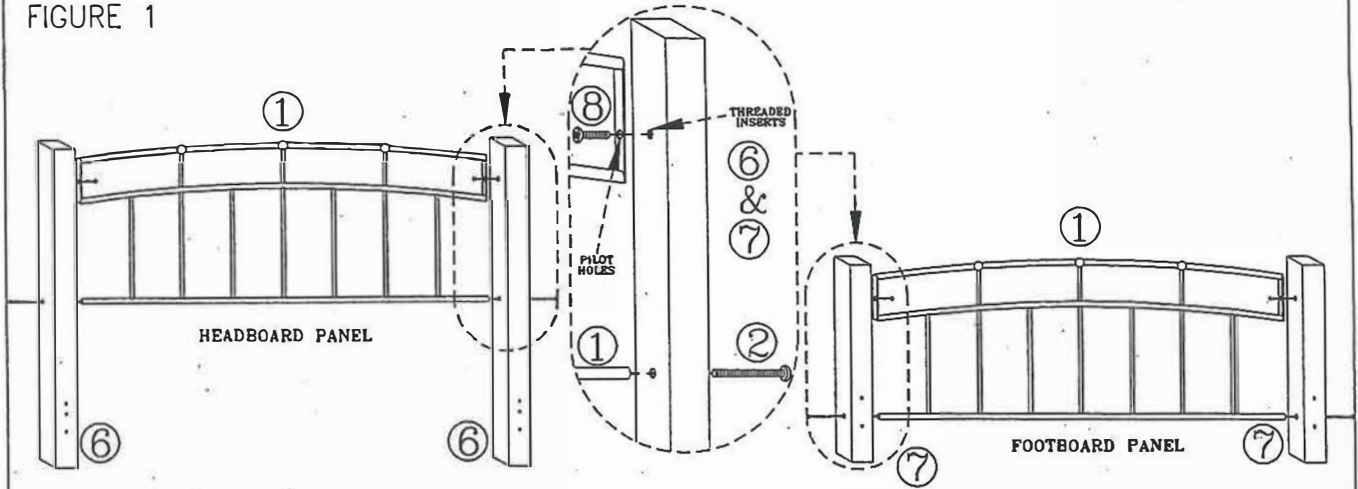
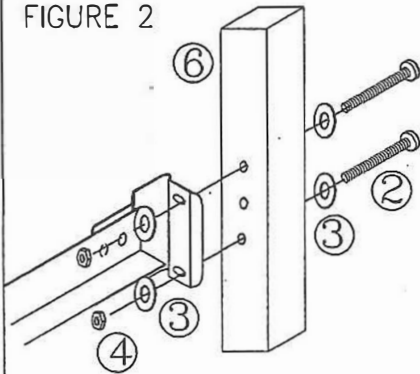

FIGURE 2



### Step 1- Assembly of Headboard and Footboard Grills.

- Align pilot holes on headboard grill (1) with threaded inserts on headboard post (6). SEE FIGURE 1
- Secure headboard grill (1) to headboard post (6) with screw (2 & 8). Use Allen wrench (5) to tighten.
- Repeat same steps with footboard panel (1) and footboard post (7).

### Step 2- Assembly of Headboard Panel to Frame.

- Place headboard panel and frame in desired location in room.
- Place flat metal washer (3) over screw (2). SEE FIGURE 2
- Insert screw (2) through holes located in post (6).
- Align bed frame over screw (2).
- Place flat metal washer (3) first and then a hex nut (4) on each screw (2). DO NOT TIGHTEN SCREWS COMPLETELY.
- Repeat on other side of headboard.
- Tighten all screws (2) securely. Using Allen wrench to tighten (5).

FIGURE 3

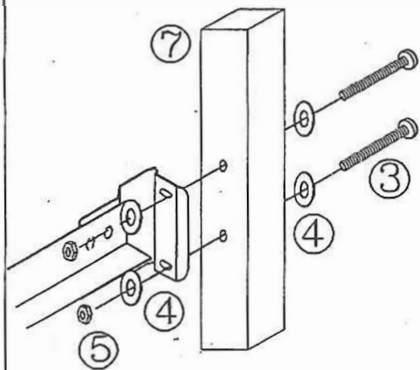







### Step 3- Assembly of Footboard Panel to Frame.

- Position footboard panel and align holes on post (7) with holes in the frame bracket. SEE FIGURE 3
- Place flat metal washer (3) over screw (2).
- Insert screw (2) through holes located in post (7).
- Align bed frame over screw (2).
- Place flat metal washer (3) first and then a hex nut (4) on each screw (2). DO NOT TIGHTEN SCREWS COMPLETELY.
- Repeat on other side of footboard.
- Tighten all screws (2) securely. Using Allen wrench to tighten (5).

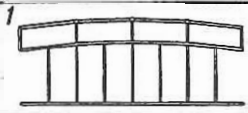
# FASHION BED GROUP®

A  COMPANY

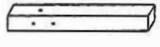
## Lista de Partes para la Cama Benson

CAJAS DE LA CAMA	CAJAS DE LA CABECERA		
<b>CAJA DE REJILLAS</b> (1) REJILLA DE LA CABECERA/PIECERA (2)	<b>CAJA DE LA REJILLAS</b> (1) REJILLA DE LA CABECERA (1)		
<b>PARTE #397601 BOLSA DE PIEZAS PARA LA FIJACIÓN DEL ARMAZÓN</b> (2) TORNILLO ALLEN DE CABEZA PLANA DE 6MM X 80MM -8 (3) RONDANA DE METAL PLANA 6MM DI -18 (4) TUERCAS HEXAGONALES 6MM -8 (5) LLAVE ALLEN-1	<b>PARTE #397603 BOLSA DE PIEZAS PARA LA FIJACIÓN DEL ARMAZÓN DE LA CABECERA</b> (2) TORNILLO ALLEN DE CABEZA PLANA DE 6MM X 80MM -4 (3) RONDANA DE METAL PLANA 6MM DI -8 (4) TUERCAS HEXAGONALES 6MM -4 (5) LLAVE ALLEN-1		
<b>CAJA DEL POSTE</b> (6) POSTE DE LA CABEZA-2 (7) POSTE DE LA PIECERA-2	<b>CAJA DEL POSTE</b> (6) POSTE DE LA CABECERA-2		
<b>PARTE #397602 BOLSA DE PIEZAS PARA EL ENSAMBLE DE LA REJILLA DE LA CAMA</b> (2) TORNILLO ALLEN DE CABEZA PLANA DE 6MM X 8MM-4 (8) TORNILLO ALLEN DE CABEZA PLANA DE 6MM X 20MM-4 (5) LLAVE ALLEN-1	<b>PARTE #397604 BOLSA DE PIEZAS PARA EL ENSAMBLE DE LA REJILLA DE LA CABECERA</b> (2) TORNILLO ALLEN DE CABEZA PLANA DE 6MM X 80MM-2 (8) TORNILLO ALLEN DE CABEZA PLANA DE 6MM X 20MM-2 (5) LLAVE ALLEN-1		

## PRODUCTO TOTALMENTE ENSAMBLADO

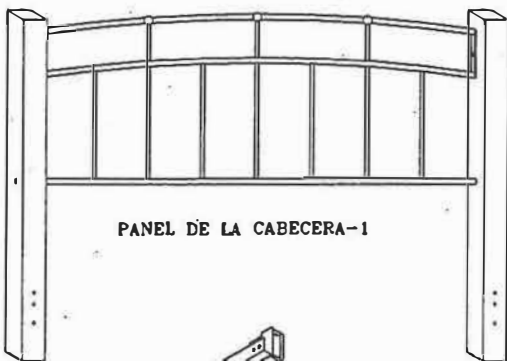

PANEL DE LA CABECERA-1

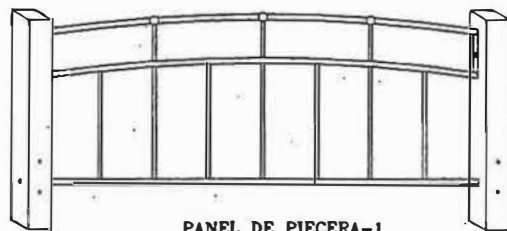

PANEL DE PIECERA-1

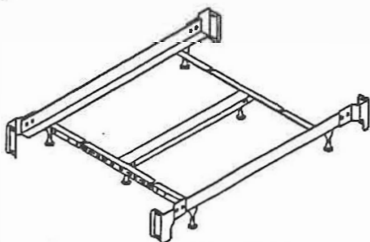

ARMAZÓN DE CAMA QUEEN - KING TOTALMENTE ENSAMBLADO  
 NOTA: VER INSTRUCCIONES INCLUIDAS EN LA CAJA DEL ARMAZÓN PARA EL ENSAMBLE DEL ARMAZÓN

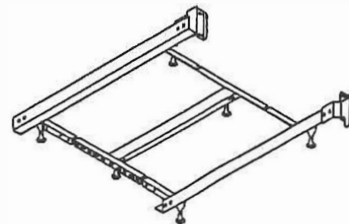

ARMAZÓN DE LA CABECERA QUEEN - KING UNICAMENTE ARMAZONES TOTALMENTE ENSAMBLADOS  
 NOTA: VER INSTRUCCIONES INCLUIDAS EN LA CAJA DEL ARMAZÓN PARA EL ENSAMBLE DEL ARMAZÓN

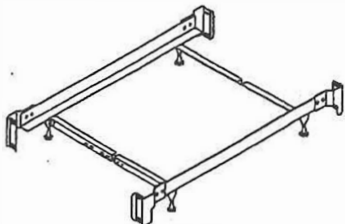

ARMAZÓN DE LA CAMA GEMELAS - MATRIMONIAL TOTALMENTE ENSAMBLADO  
 NOTA: VER INSTRUCCIONES INCLUIDAS EN LA CAJA DEL ARMAZÓN PARA EL ENSAMBLE DEL ARMAZÓN

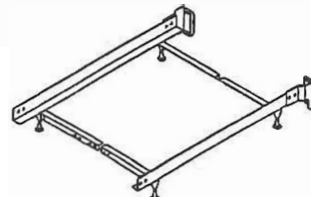

ARMAZÓN DE LA CABECERA GEMELAS Y MATRIMONIAL SOLAMENTE TOTALMENTE ENSAMBLADO  
 NOTA: VER INSTRUCCIONES INCLUIDAS EN LA CAJA DEL ARMAZÓN PARA EL ENSAMBLE DEL ARMAZÓN

## Hoja de Instrucciones

GUARDE TODO EL MATERIAL DE EMPAQUE HASTA QUE EL PRODUCTO ESTÉ TOTALMENTE ENSAMBLADO. ES POSIBLE QUE EL MATERIAL Y LAS PIEZAS PEQUEÑAS NO SE VEAN Y SE DESECHEN ACCIDENTALMENTE CON EL MATERIAL DE EMPAQUE.

FIGURA 1



FIGURA 2



### Paso 1 - Ensamblaje de la rejilla de la cabecera y la piecera.

- Alinee los orificios guía en la rejilla de la cabecera (1) con insertos roscados en el poste de la cabecera (6). VER LA FIGURA 1
- Asegure la rejilla de la cabecera (1) al poste de la cabecera (6) con tornillos (2 y 8). Use la llave Allen para ajustar (5). Use la llave Allen para ajustar (5).
- Repita los mismos pasos con el panel de piecera (1) y el poste de piecera (7).

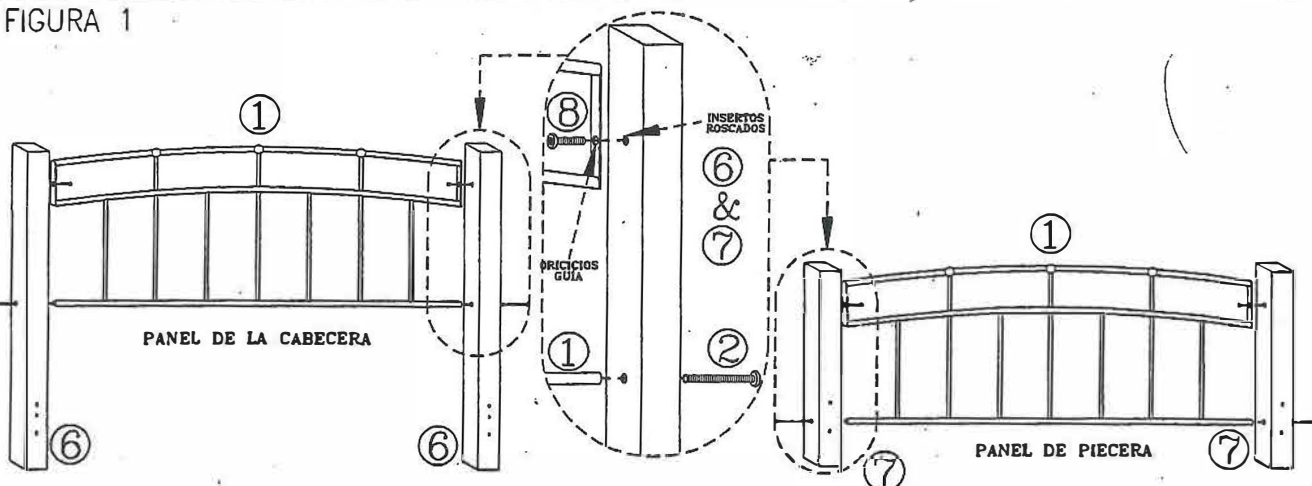
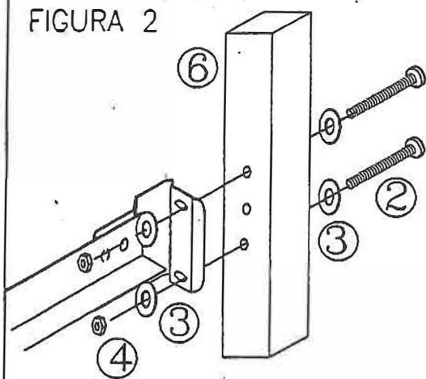
### Paso 2-Ensamblaje del panel de la cabecera al armazón .

- Coloque el panel de la cabecera al armazón en la ubicación deseada en el cuarto.
- Coloque la rondana de metal plana (3) sobre el tornillo (2). VER LA FIGURA 2
- Inserte tornillos (2) a través de los orificios ubicados en el poste (6).Align bed frame over screw (2).
- Coloque la rondana de metal plana (3) primero y luego una tuerca hexagonal (4) en cada tornillo (2).
- NO AJUSTE LOS TORNILLOS POR COMPLETO TODAVIA.
- Repita el paso en el otro lado de la cabecera.
- Ajuste bien todos los tornillos (2). Use la llave Allen para ajustar (5).

FIGURA 3

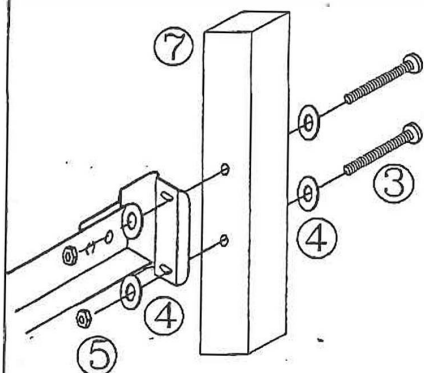

### Paso 3-Ensamblaje del panel de la piecera al armazón

- Posicione el panel de la piecera y alinee los orificios en el poste (7) con los orificios en el soporte del armazón. VER LA FIGURA 3
- Coloque la rondana de metal plana (3) sobre el tornillo (2).Insert screw (2) through holes located in post (7).
- Alinee el armazón de la cama sobre los tornillos (2).
- Coloque la rondana de metal plana (3) primero y luego una tuerca hexagonal (4) en cada tornillo (2). NO AJUSTE LOS TORNILLOS POR COMPLETO TODAVIA.
- Repita el paso en el otro lado de la piecera.
- Ajuste bien todos los tornillos (2). Use la llave Allen para ajustar (5).

# FASHION BED GROUP®

A  COMPANY

## Liste de pièces pour lit Benson

### CARTONS DU LIT

#### BOÎTE DE GRILLES

(1) GRILLE DE LA TÊTE DE LIT/OU PIED DE LIT (2)

PIÈCE N°397601 QUINCAILLERIE POUR FIXATION DE CADRE

(2) VIS À SIX PANS À TÊTE PLATE 6MM X 80MM-8  
(3) RONDELLE MÉTALLIQUE PLATE DI 6MM-16  
(4) ÉCROUS HEXAGONAUX 6MM-8  
(5) CLÉ HEXAGONALE-1

#### BOÎTE DU POTEAU

(6) POTEAU DE LA TÊTE DE LIT-2  
(7) POTEAU DU PIED DE LIT-2

PIÈCE N° 397602 SAC DE VISSERIE POUR ASSEMBLAGE DE LA GRILLE DE LIT

(2) VIS À SIX PANS À TÊTE PLATE 6MM X 80MM-4  
(8) VIS À SIX PANS À TÊTE PLATE 6MM X 20MM-4  
(5) CLÉ HEXAGONALE-1

### CARTONS DE LA TÊTE DE LIT

#### BOÎTE DE GRILLES

(1) GRILLE DE LA TÊTE DE LIT (1)

PIÈCE N°397603 SAC DE VISSERIE POUR FIXATIONS DE CADRE DE TÊTE DE LIT

(2) VIS À SIX PANS À TÊTE PLATE 6MM X 80MM-4  
(3) RONDELLE MÉTALLIQUE PLATE DI 6MM-8  
(4) ÉCROUS HEXAGONAUX 6MM-4  
(5) CLÉ HEXAGONALE-1

#### BOÎTE DU POTEAU

(6) POTEAU DE LA TÊTE DE LIT - 2

PIÈCE N° 397604 SAC DE VISSERIE POUR ASSEMBLAGE DE LA GRILLE DE LA TÊTE DE LIT

(2) VIS À SIX PANS À TÊTE PLATE 6MM X 80MM-2  
(8) VIS À SIX PANS À TÊTE PLATE 6MM X 20MM-2  
(5) CLÉ HEXAGONALE-1

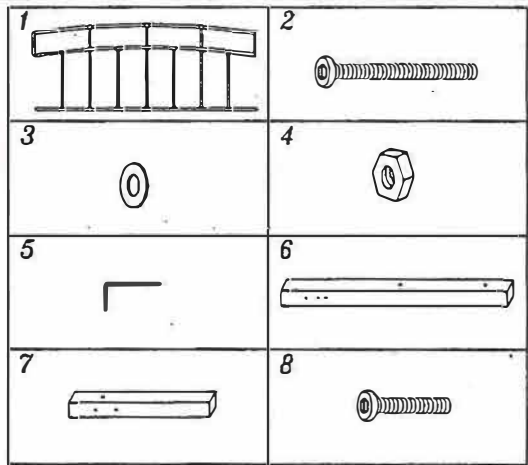

## PRODUIT COMPLÈTEMENT ASSEMBLÉ

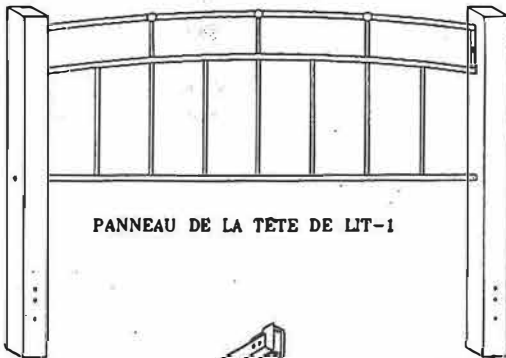

PANNEAU DE LA TÊTE DE LIT-1

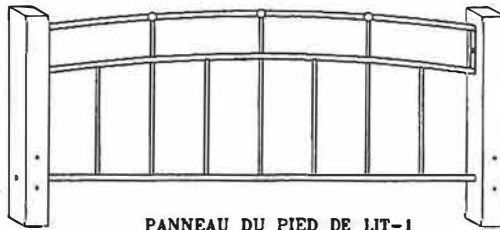

PANNEAU DU PIED DE LIT-1

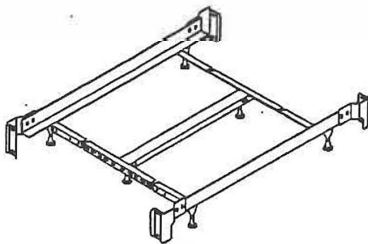

CADRE DE LIT GRANDE - TRÈS GRANDE COMPLÈTEMENT ASSEMBLÉ

REMARQUE : VOIR LES INSTRUCTIONS INCLUSES DANS LE CARTON DU CADRE POUR L'ASSEMBLAGE DU CADRE

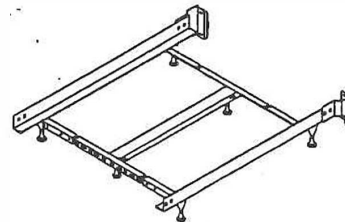

CADRE DE LA TÊTE DE LIT GRAND - TRÈS GRAND SEULEMENT CADRES COMPLÈTEMENT ASSEMBLÉS

REMARQUE : VOIR LES INSTRUCTIONS INCLUSES DANS LE CARTON DU CADRE POUR L'ASSEMBLAGE DU CADRE

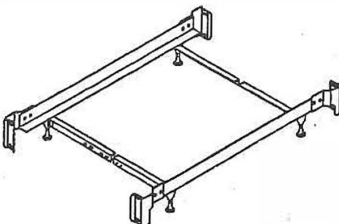

CADRE DE LIT Jumeau - DOUBLE COMPLÈTEMENT ASSEMBLÉ

REMARQUE : VOIR LES INSTRUCTIONS INCLUSES DANS LE CARTON DU CADRE POUR L'ASSEMBLAGE DU CADRE

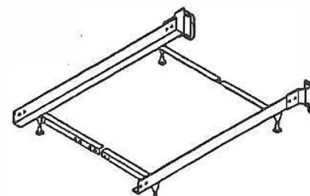

CADRE DE LA TÊTE DE LIT Jumeau - DOUBLE SEULEMENT, COMPLÈTEMENT ASSEMBLÉ

REMARQUE : VOIR LES INSTRUCTIONS INCLUSES DANS LE CARTON DU CADRE POUR L'ASSEMBLAGE DU CADRE

## Feuille d'instructions

CONSERVER TOUS LES MATÉRIEAUX D'EMBALLAGE JUSQU'À CE QUE L'ARTICLE SOIT ENTièrement ASSEMBLÉ. CERTAINS PETITS ÉLÉMENTS DE FIXATION POURRAIENT PASSER INAPÉRÇUS ET ÊTRE JETÉS ACCIDENTELLEMENT AVEC L'EMBALLAGE.

FIGURE 1

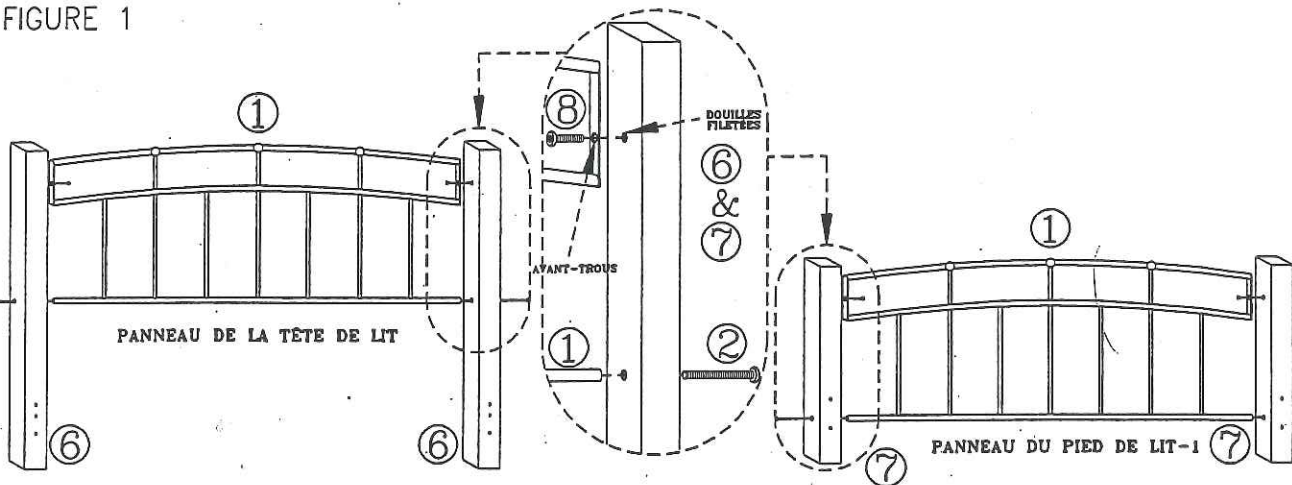

FIGURE 2

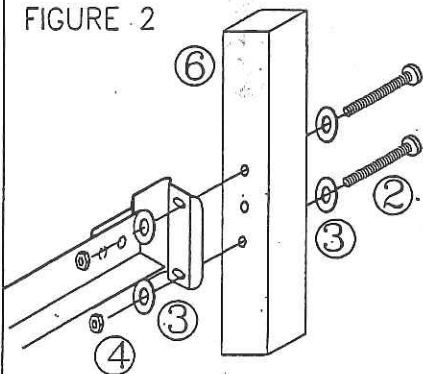
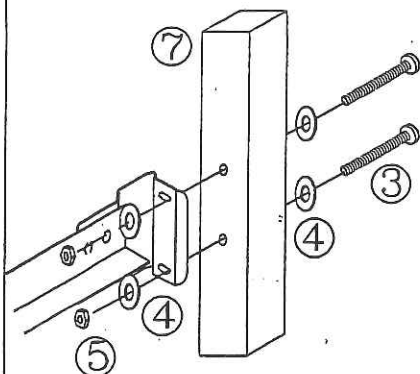

FIGURE 3



### Étape 1 - Assemblage de grille de la tête de lit et du pied de lit.

- Aligner les avant-trous sur la grille de la tête de lit (1) avec les douilles filetées sur le poteau de la tête de lit (6). VOIR LA FIGURE 1
- Fixer la grille de la tête de lit (1) au poteau de la tête de lit (6) avec une vis (2 et 8). Utiliser une clé hexagonale (5) pour serrer.
- Répéter les mêmes étapes pour le panneau du pied de lit (1) et le poteau du pied de lit (7).

### Étape 2 - Assembler le panneau de la tête de lit au cadre.

- Placer le panneau et le cadre de tête de lit à l'emplacement souhaité dans la chambre.
- Placer la rondelle métallique plate (3) sur la vis (2). VOIR LA FIGURE 2
- Insérer une vis (2) dans les trous se trouvant sur le poteau (6).
- Aligner le cadre de lit sur la vis (2).
- D'abord, placer une rondelle métallique plate (3), puis un écrou hexagonal (4) sur chaque vis (2). NE PAS SERRER LES VIS ENCORE COMPLÈTEMENT.
- Répéter sur l'autre côté de la tête de lit.
- Serrer fermement toutes les vis (2). Utiliser une clé hexagonale (5) pour serrer.

### Étape 3 - Assembler le panneau du pied de lit au cadre.

- Positionner le panneau du pied de lit et aligner les trous dans le poteau (7) avec les trous dans le support du cadre. VOIR LA FIGURE 3.
- Placer la rondelle métallique plate (3) sur la vis (2).
- Insérer une vis (2) dans les trous se trouvant sur le poteau (7).
- Aligner le cadre de lit sur la vis (2).
- D'abord, placer une rondelle métallique plate (3), puis un écrou hexagonal (4) sur chaque vis (2).
- NE PAS SERRER LES VIS ENCORE COMPLÈTEMENT.
- Répéter sur l'autre côté du pied de lit.
- Serrer fermement toutes les vis (2). Utiliser une clé hexagonale (5) pour serrer.