

Read through ALL instructions before commencing installation.

If you have any questions about this product or issues with installation, contact the customer services helpline before returning this product to the store.



Lisez TOUTES les instructions avant de débiter l'installation.

Si vous avez des questions sur ce produit ou des problèmes d'installation, contactez l'assistance client avant de ramener le produit en magasin.



Lea TODAS las instrucciones antes de comenzar la instalación.

Si tiene alguna pregunta sobre el producto o problemas con la instalación, llame a la línea de servicio al consumidor antes de devolverlo.

IMPORTANT INFORMATION!

We advise that before starting the assembly of this product that you familiarise yourself with the instructions and the parts list in this leaflet.

INFORMATIONS IMPORTANTES!

Nous vous recommandons de vous familiariser avec ces instructions et la liste des pièces détachées contenues dans ce document avant de commencer l'assemblage de ce produit.

INFORMACIÓN IMPORTANTE!

Le recomendamos que antes de comenzar el ensamblaje de este producto se familiarize con las instrucciones y la lista de partes en esta hoja informativa.

Do not's

Do not overtighten any part of this assembly.

Do not place hot or cold objects on to or next to any surface unless the object is sufficiently insulated to prevent contact.

Do not strike any part of the stand with hard or pointed items.

Do not sit, stand or climb upon any part of this furniture.

Do not use washing powders or other substances containing abrasives when cleaning the wood or glass.

À ne pas faire

Ne serrez pas trop fort aucun des éléments de cet assemblage.

Ne placez pas d'objets chauds ou froids sur ou à côté d'une surface, sauf si l'objet est suffisamment isolés pour éviter tout contact.

Ne frappez aucune partie du support avec des objets durs ou pointus.

Ne pas vous asseoir, vous tenir debout ou grimper sur toute partie de ce meuble.

N'utilisez pas de poudres à laver ou d'autres substances contenant des abrasifs pour nettoyer le bois ou le verre.

No haga

No apriete demasiado ninguna de las piezas de este soporte.

No situar objetos calientes o fríos sobre o al lado de cualquier superficie a menos que el objeto esté suficientemente aislado para evitar el contacto.

No golpear ninguna parte del soporte con objetos duros o afilados.

No se siente ni se pare ni se suba sobre ninguna parte de este mobiliario.

No usar detergentes u otras sustancias que contengan elementos abrasivos al limpiar la madera o el cristal.

Do's

Do use a soft cloth with a suitable furniture polish when cleaning wooden panels.

Do use a damp cloth with diluted washing up liquid for cleaning the glass surfaces.

Check all nuts and bolts from time to time.

À faire

Utilisez un chiffon doux avec un produit adapté pour le nettoyage des meubles afin de nettoyer les panneaux en bois.

Utilisez un chiffon humide imprégné de liquide vaisselle dilué pour le nettoyage des surfaces en verre.

Vérifiez tous les écrous et les boulons de temps à autre.

Si haga

Use un trapo suave con limpiador o embellecedor de muebles cuando limpie páneces de madera.

Use un trapo suave con líquido diluido en agua para limpiar las superficies de vidrio.

Compruebe todos los tornillos y tuercas de vez en cuando.

Maximum TV weight and shelf capacities

Poids maximal du téléviseur et capacité de charge de l'étagère

Máximo peso y capacidad del estante de TV

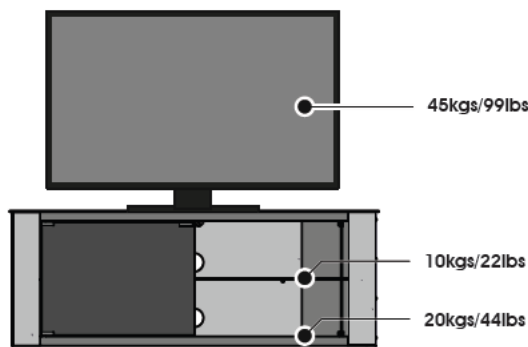

WARNING: Wherever possible distribute weight evenly.

AVERTISSEMENT: Répartissez le poids de manière uniforme lorsque cela est possible.

ADVERTENCIA: En la medida de lo posible distribuya el peso uniformemente.

Boxed Parts
Pièces empaquetées
Piezas en la Caja

Tools Recommended
Outils recommandés
Herramientas recomendadas

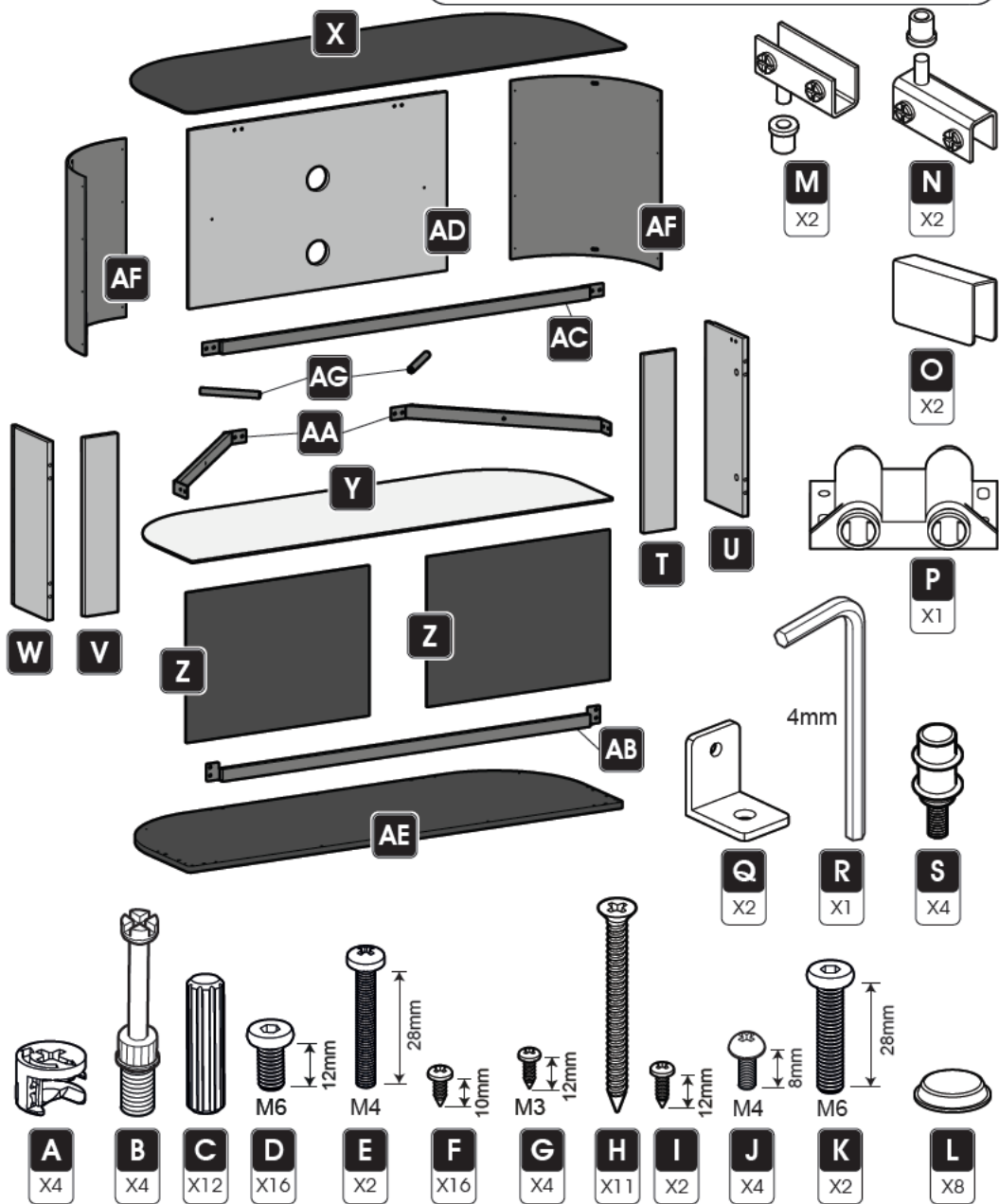

1

M3
12mm

G

X4

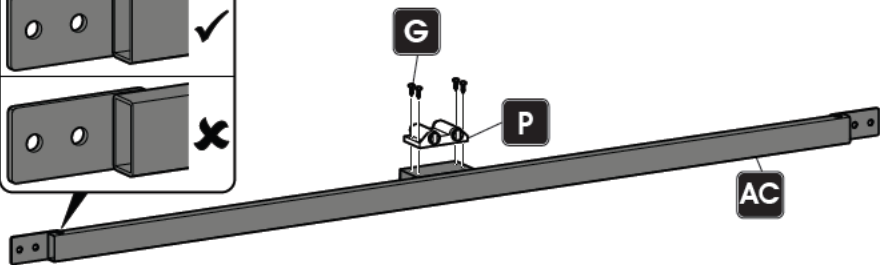
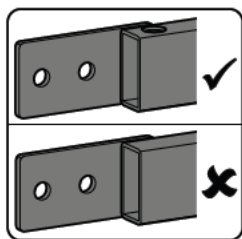

2

i

Arrow
Flèche
Flecha



Always ensure that the arrow on part A points towards the edge of the panel.
Assurez-vous que la flèche sur la partie A soit dirigée vers le bord du panneau.
Siempre asegúrese de que la flecha en la parte A apunta hacia el borde del panel.

i

DO NOT overtighten
Ne serrez pas trop fort
No apriete demasiado

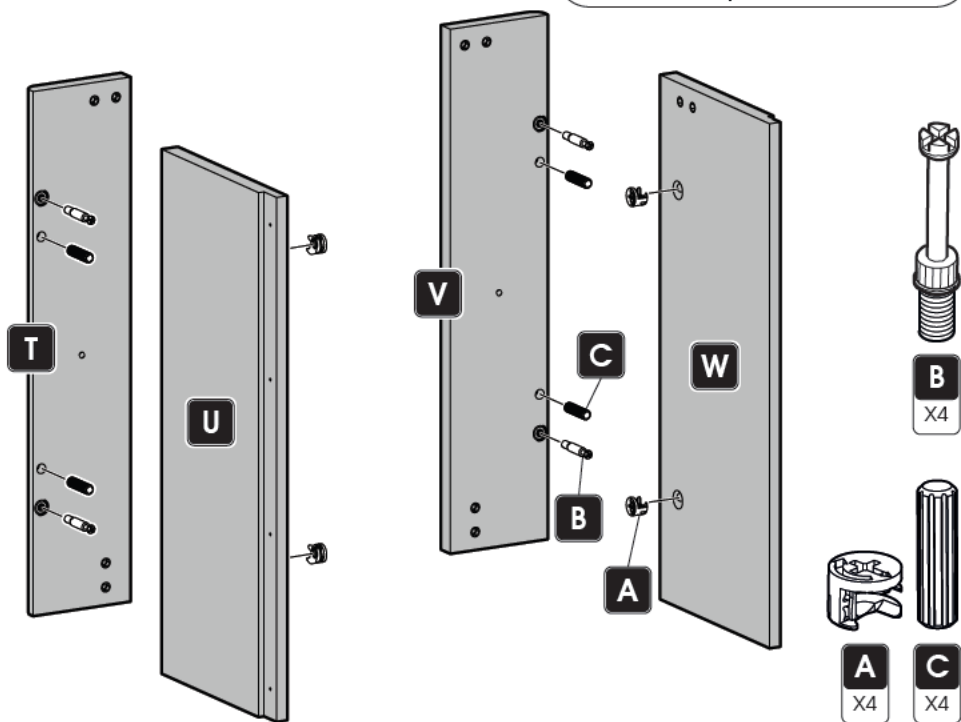

B

X4

A

X4

C

X4

3

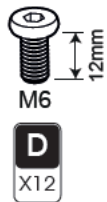
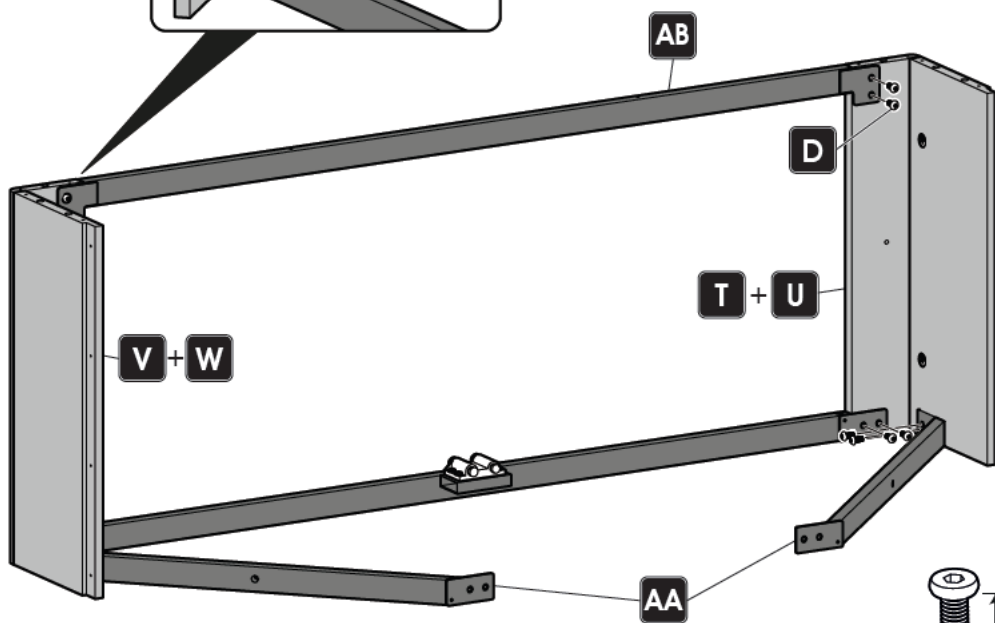
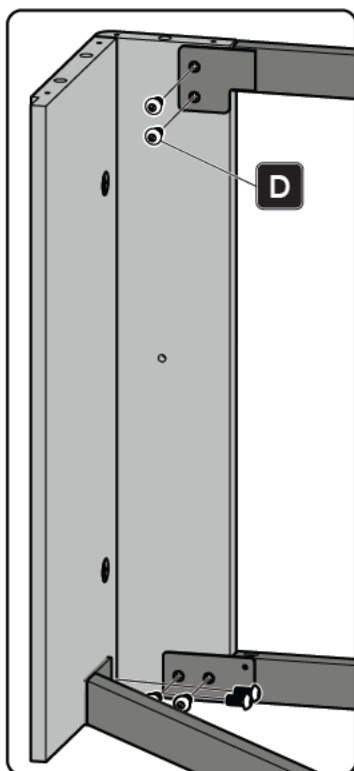

4

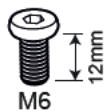
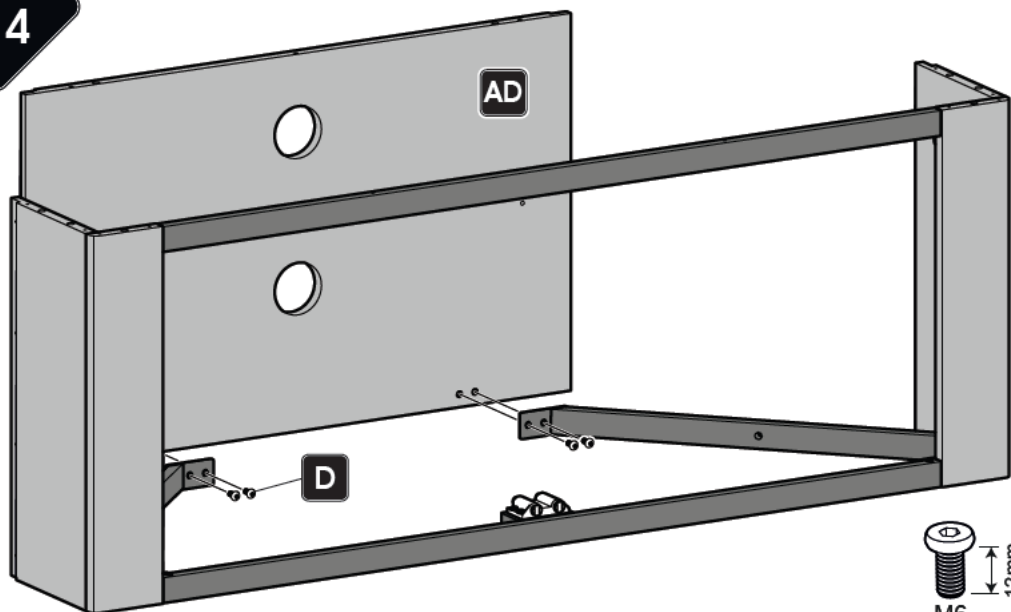

D
X4

5

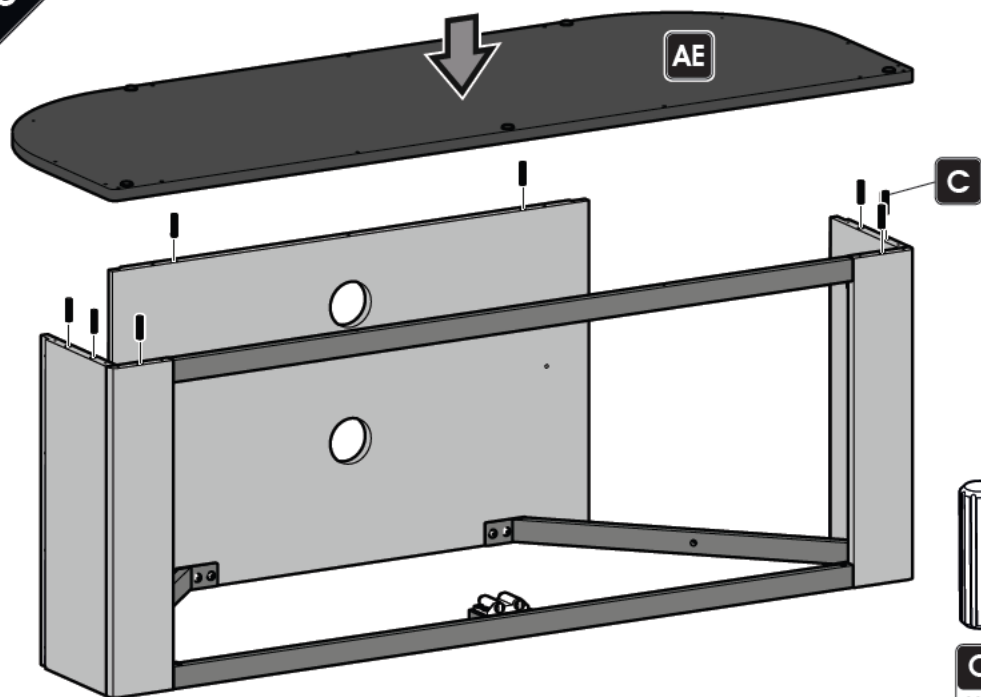

C
X8

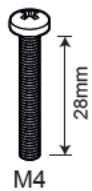
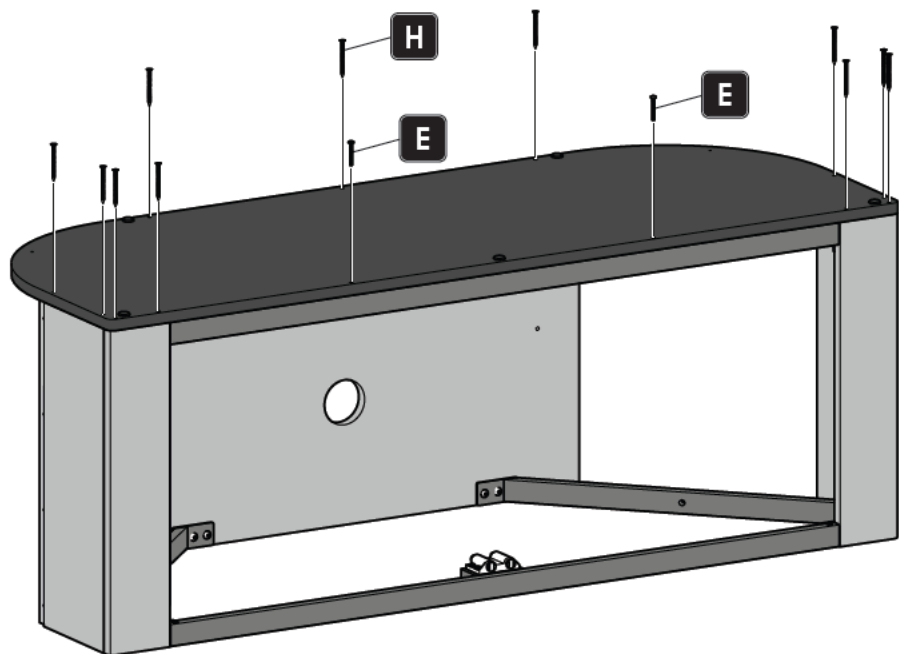

6

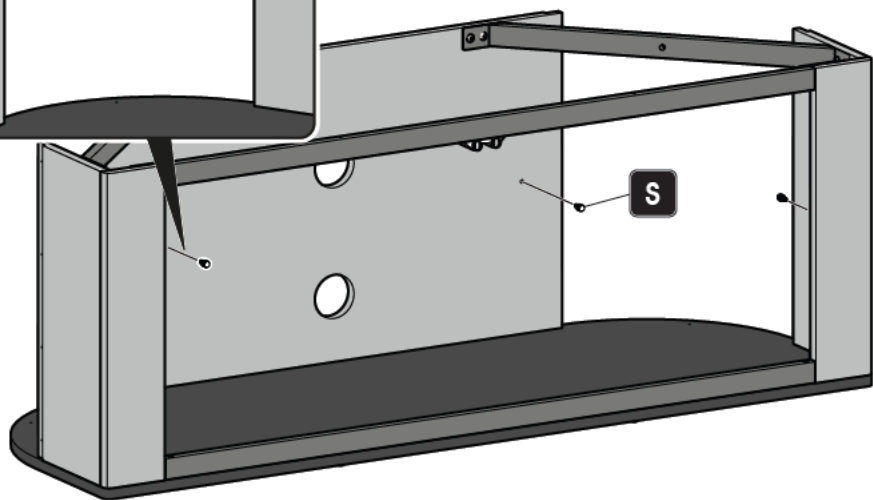
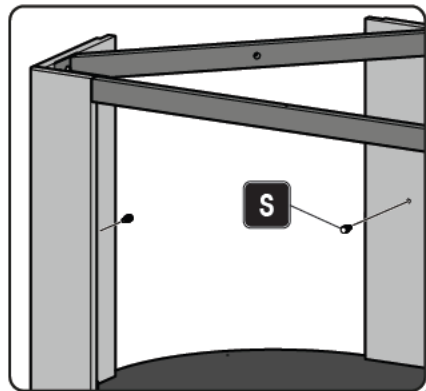

7

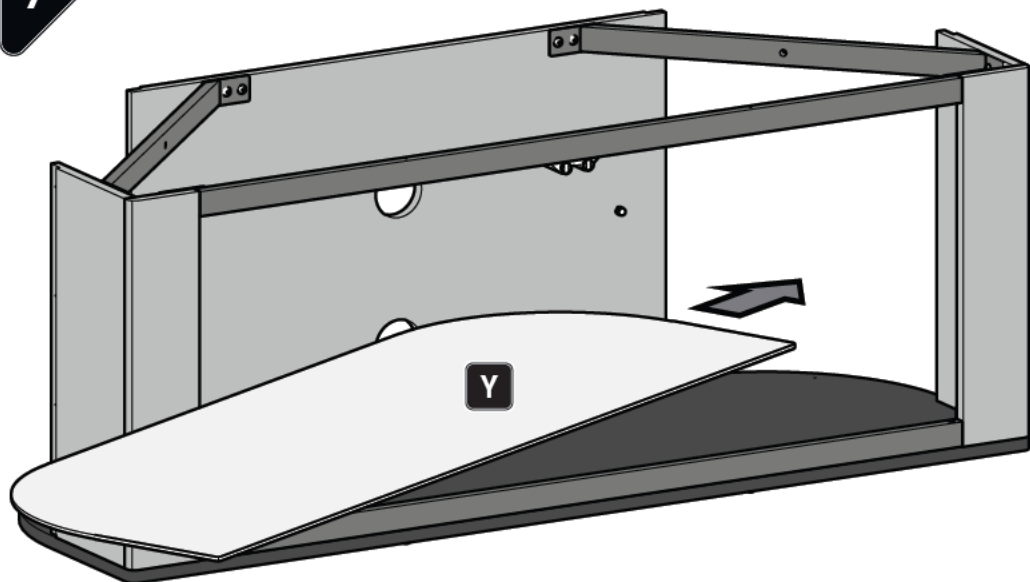

8

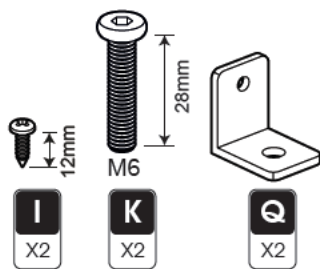
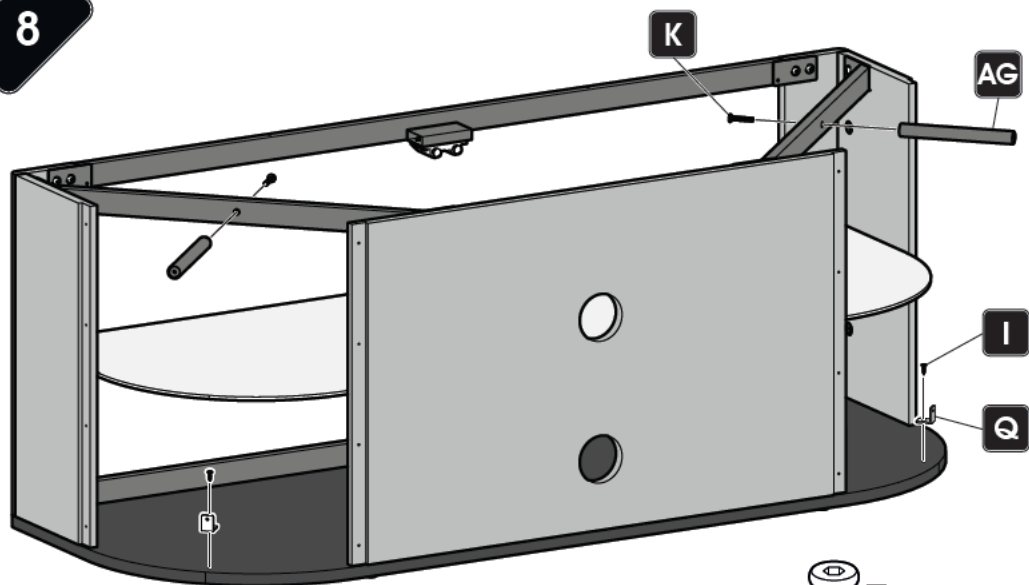

9

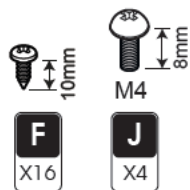
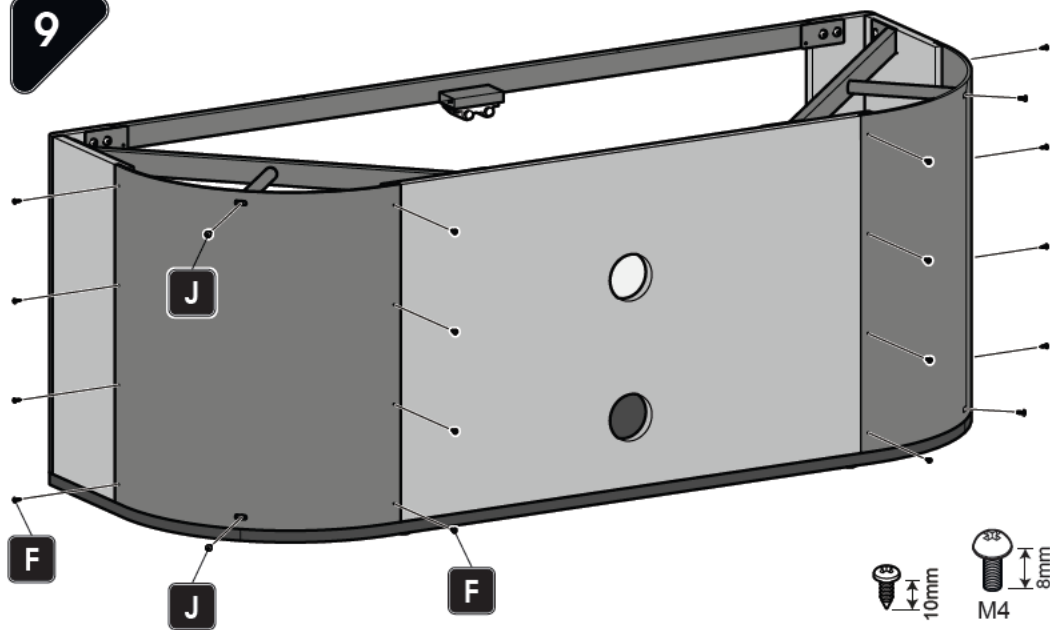

10

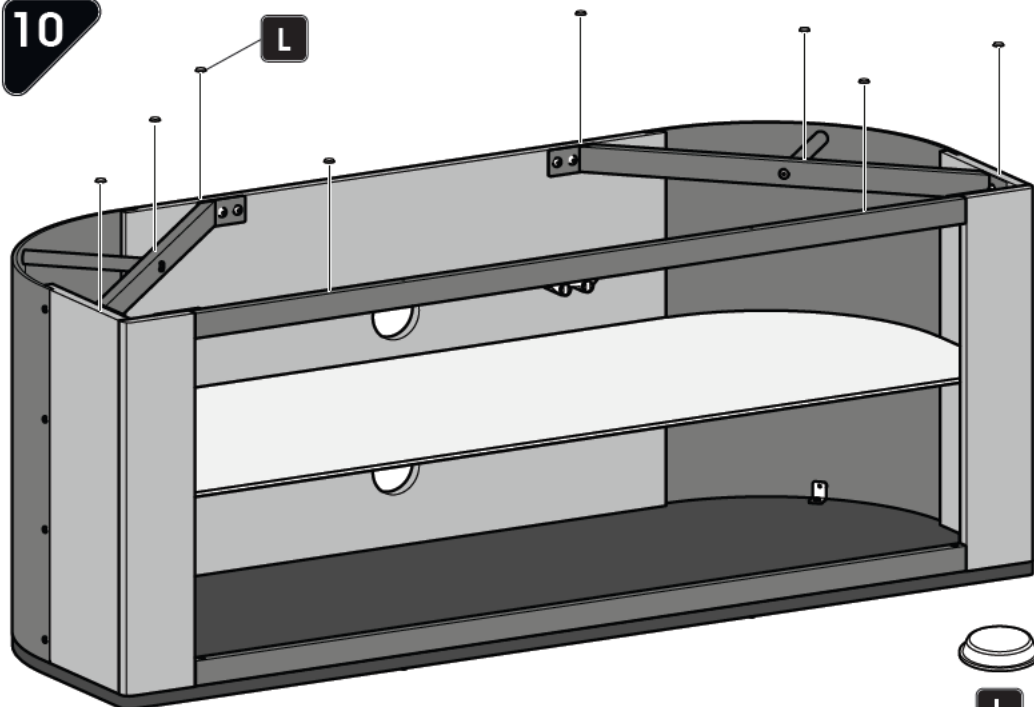

Doors are optional
 Les portes sont optionnelles
 Las puertas son opcionales



Take care
 Faire attention
 Tenga cuidado

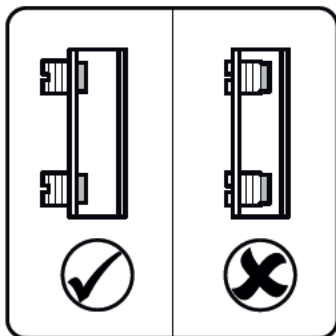
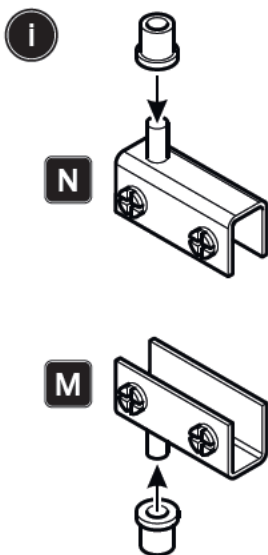

ii

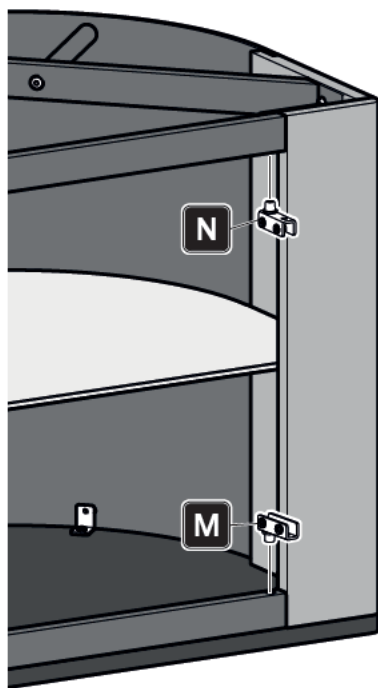
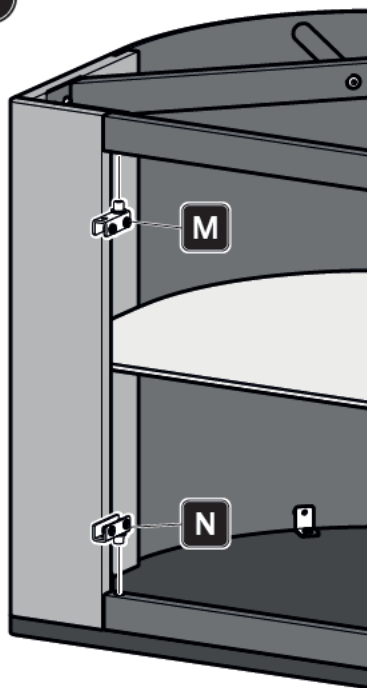

iii

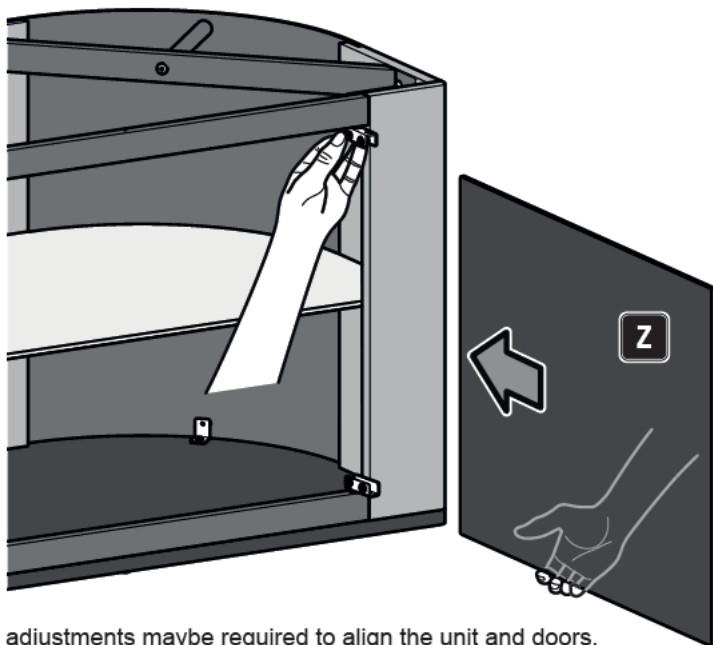

i

Small adjustments may be required to align the unit and doors.
De légers ajustements pourront être requis pour aligner l'unité avec les portes.
Es posible que se requieran pequeños ajustes para alinear la unidad y las puertas.

iv

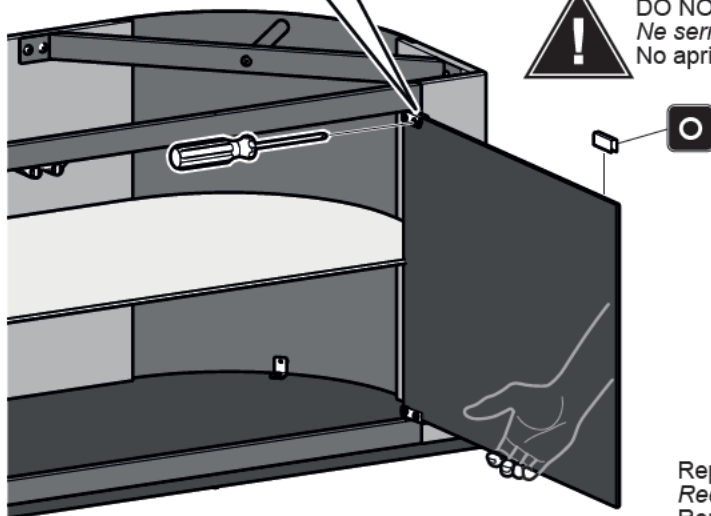
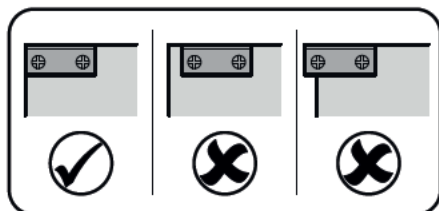

DO NOT overtighten
Ne serrez pas trop fort
No apriete demasiado

Repeat for other door
Recommencer pour l'autre porte
Repetir para la otra puerta

12

