

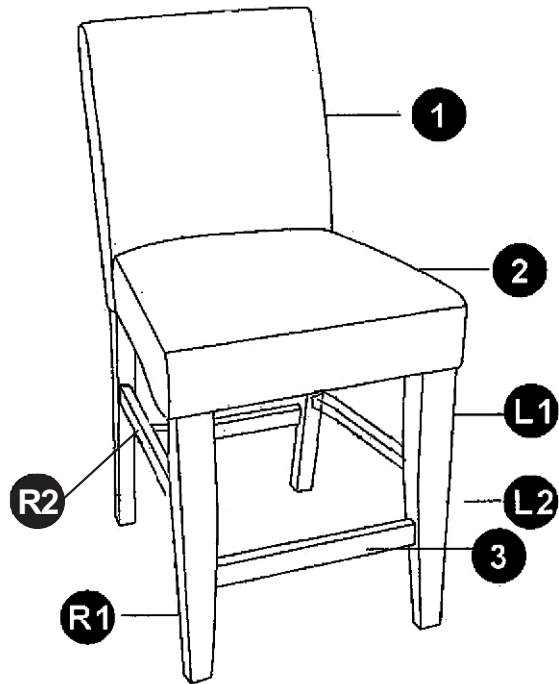



ASSEMBLING INSTRUCTION



HARDWARE LIST	CODE	PARTS	QTY.
	A	M8x60MM 	9
	B	M4.5x40MM 	6
	C	ALLEN KEY 	1

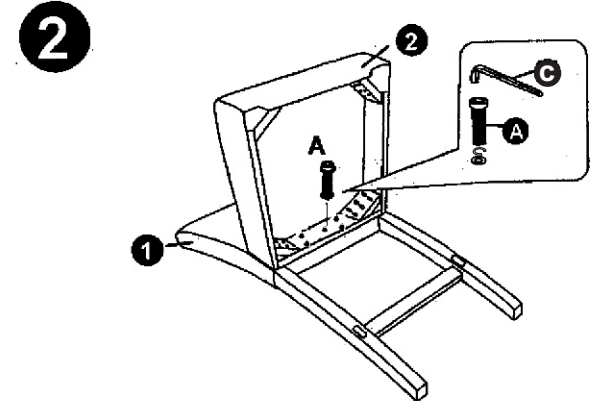
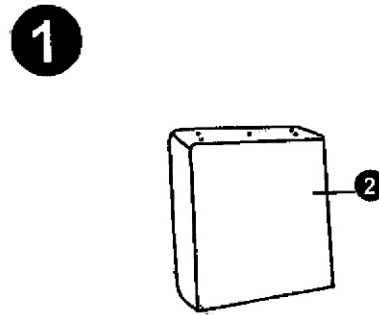

Put the screws in the holes, tight the screws, but not too tight, 90% is ok.

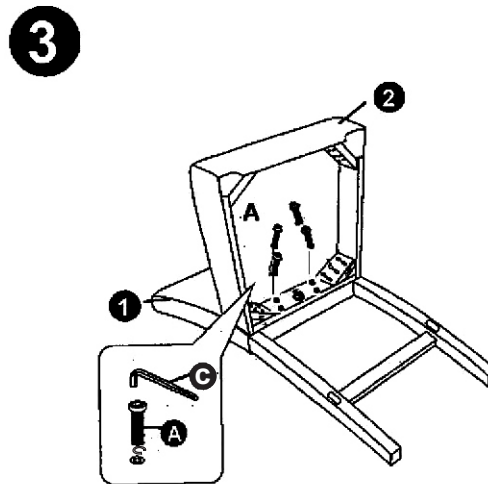

Put the screws in the holes, tight the screws, but not too tight, 90% is ok.

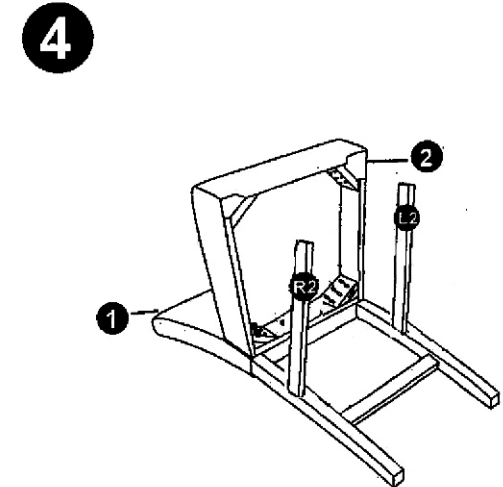

Put the L2 and R2 in the holes.

5

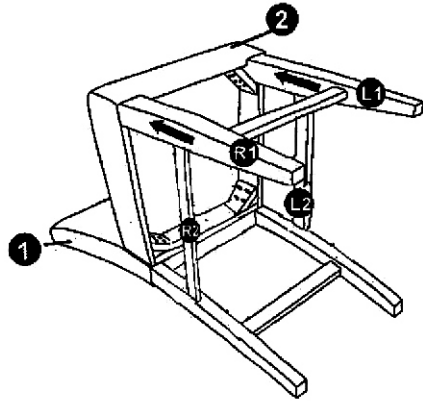

Put L1 and R2 legs in the holes.
Put 3 in the holes,

6

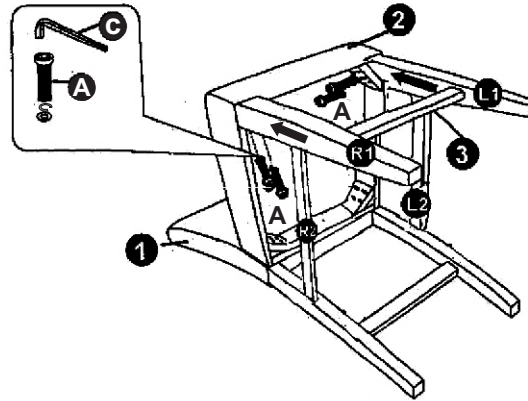

Put the screws in the holes,
tight the screws, but not too
tight, 90% is ok.

7

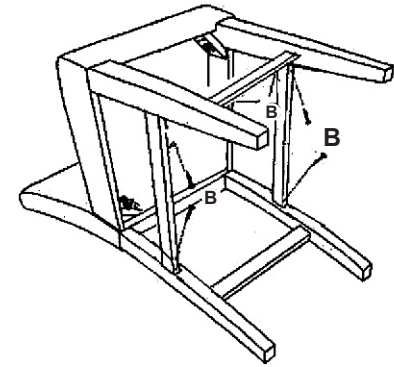

Put the screws in the holes,
tight the screws, but not too
tight, 90% is ok.

8



Then adjust the balance
of the chair.

9

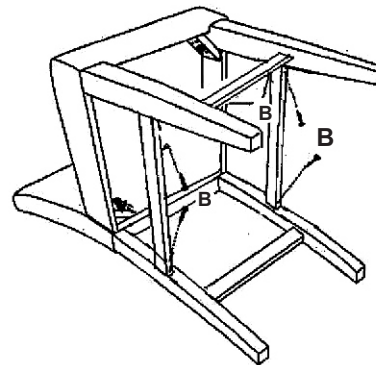

Tight all the screws to 100%

10

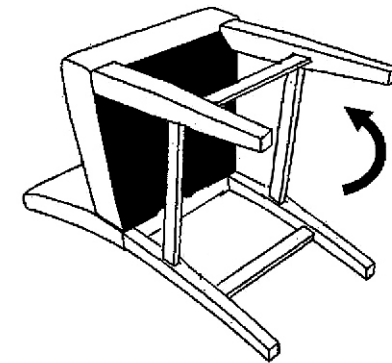

Stick the black part
on the seat