

Installation & Assembly

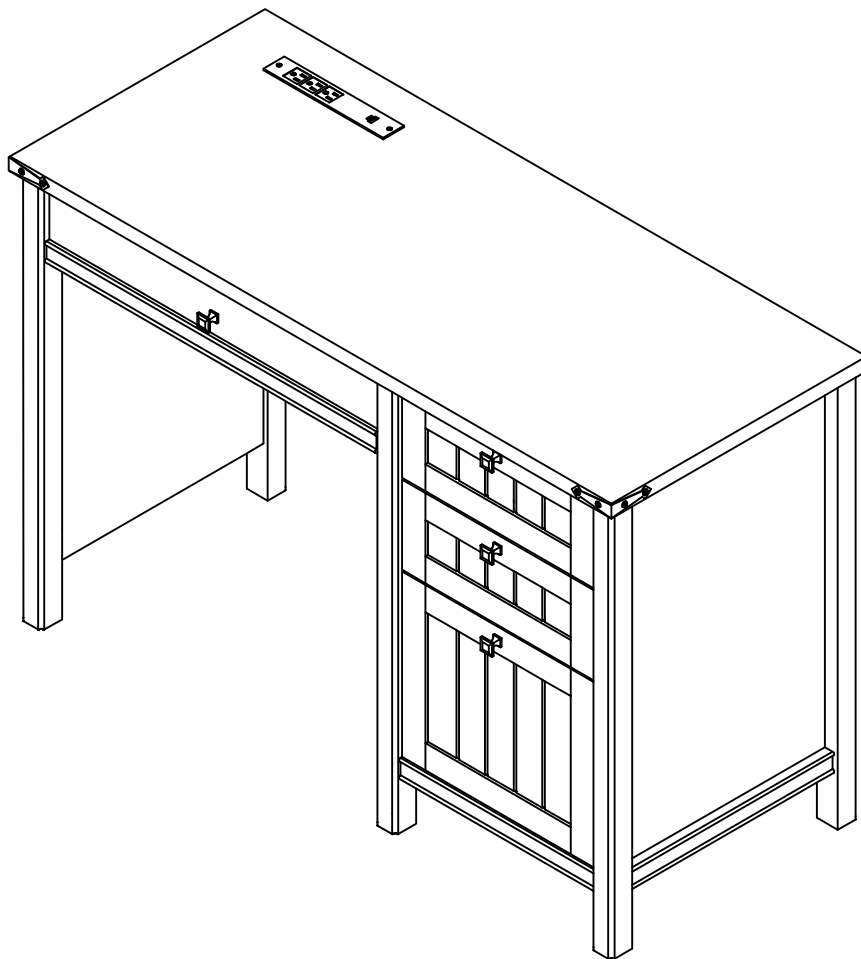

As this item contains many parts, please read the installation instruction carefully before installation . Please use tools properly and carefully. If you have any questions about the product and installation, please contact us.

Our professional after-sales team will serve you online all day.

Before You Start

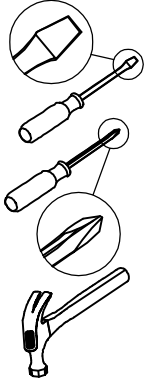

- ✓ Read through each step carefully and follow the proper order
- ✓ Separate and count all your parts and hardware
- ✓ Give yourself enough room for the assembly process
- ✓ Have the following tools: Flat Head Screwdriver, #2 Phillips Head Screwdriver and Hammer
- ✓ Caution: If using a power drill or power screwdriver for screwing, please be aware of to slow down and stop when screw is tight. Failure to do so may result in stripping the screw. (Assembly speed can be increased by using electric screwdriver)

Helpful Hints

PEOPLE NEEDED FOR ASSEMBLY: 1-2

- Open your item in the area you plan to keep it to avoid excessive heavy lifting.
- Identify, sort and count the parts before attempting assembly.
- Compression dowels are lightly tapped in with a hammer.
- Slides are labeled with an R (right) and L (left) for proper placement.
- Make sure to always face the point on the top of the Cam Lock towards the outer edge.
- If there is a back panel in the package, please install it to make sure your unit is complete and sturdy.
- Please fix all the screws provided for the back panel which can enhance product stability. If it is difficult to fix it when tightening, it can be fixed with the help of a hammer and then tightened.
- Do NOT use harsh chemicals or abrasive cleaners on this item.
- Never push, pull, or drag your furniture.



Board Identification

Not actual size

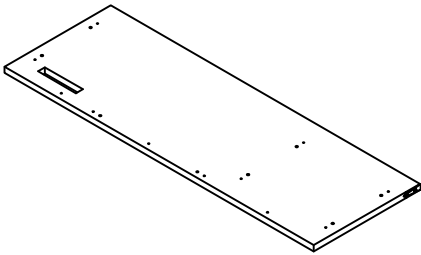

①
DESK TOP
Qty:1

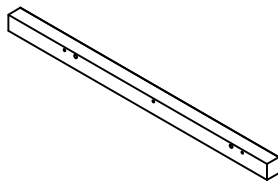

②
LEG
Qty:1

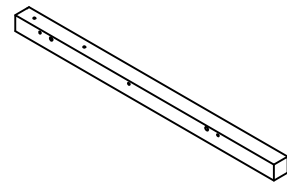

③
LEG
Qty:1

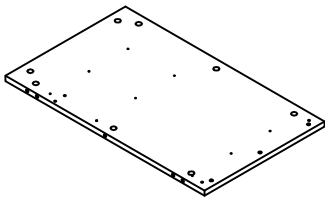

④
RIGHT SIDE PARTITION
Qty:1

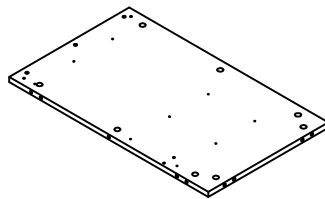

⑤
LOWER RIGHT SIDE PANEL
Qty:1

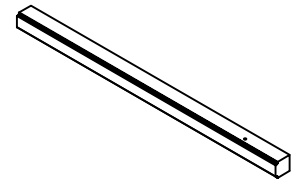

⑥
LEG
Qty:1

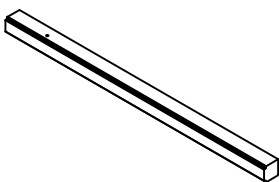

⑦
LEG
Qty:1

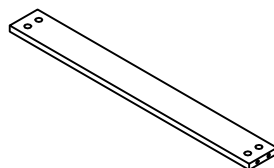

⑧
FRONT SLAT
Qty:1

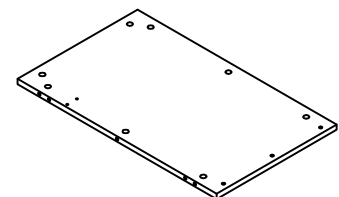

⑨
LOWER LEFT SIDE PANEL
Qty:1

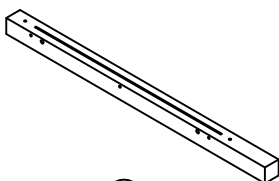

⑩
LEG
Qty:1

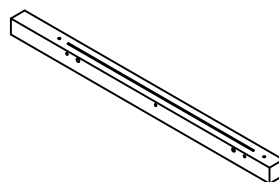

⑪
LEG
Qty:1

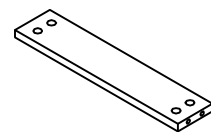

⑫
FRONT SLAT
Qty:1

Board Identification

Not actual size

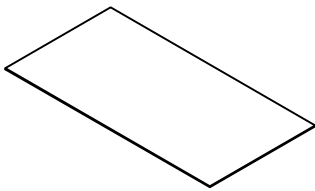

⑬
BACK PANEL
Qty:1

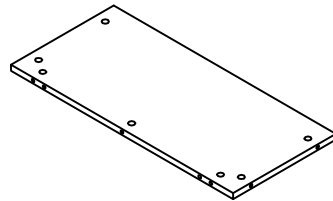

⑭
BACK SLAT
Qty:1

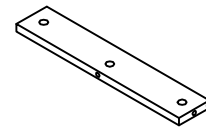

⑮
BACK SLAT
Qty:1

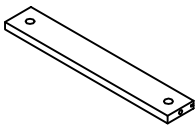

⑯
BACK SLAT
Qty:1

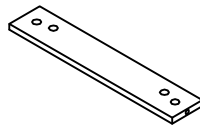

⑰
BOTTOM LINKING RAIL
Qty:2

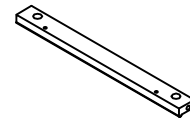

⑱
BOTTOM FRONT RAIL
Qty:1

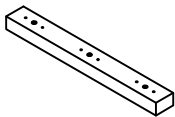

⑲
FILLER LATH FOR RUNNER
Qty:1

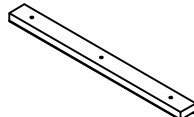

⑳
DECORATION SLAT
Qty:3

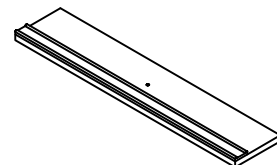

㉑
DRAWER FRONT PANEL
Qty:1

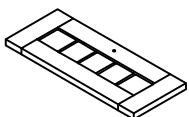

㉒
FILLER LATH FOR RUNNER
Qty:2

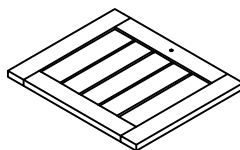

㉓
DRAWER FRONT PANEL
Qty:1

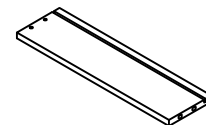

㉔
DRAWER LEFT SIDE PANEL
Qty:2

Board Identification

Not actual size

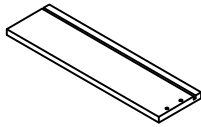

25

DRAWER RIGHT SIDE PANEL
Qty:2

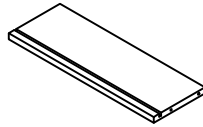

26

DRAWER BACK PANEL
Qty:2

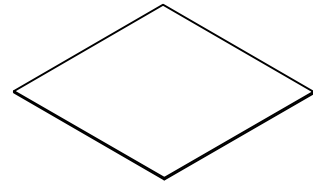

27

DRAWER BOTTOM PANEL
Qty:2

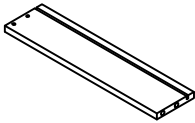

28

DRAWER LEFT SIDE PANEL
Qty:1

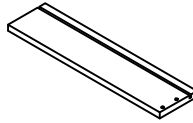

29

DRAWER RIGHT SIDE PANEL
Qty:1

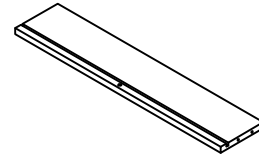

30

DRAWER BACK PANEL
Qty:1

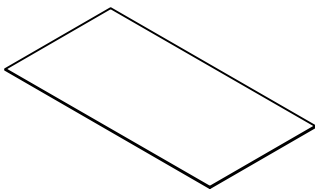

31

DRAWER BOTTOM PANEL
Qty:1

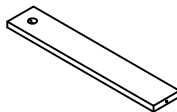

32

DRAWER BOTTOM SLAT
Qty:1

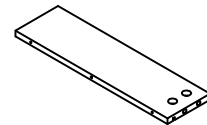

33

DRAWER LEFT SIDE PANEL
Qty:1

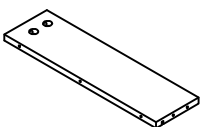

34

DRAWER RIGHT SIDE PANEL
Qty:1

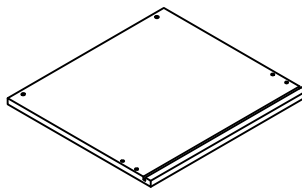

35

DRAWER BACK PANEL
Qty:1

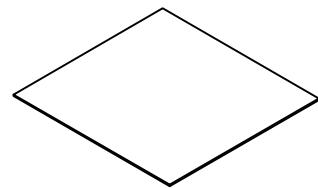

36

DRAWER BOTTOM PANEL
Qty:1

Board Identification

Not actual size

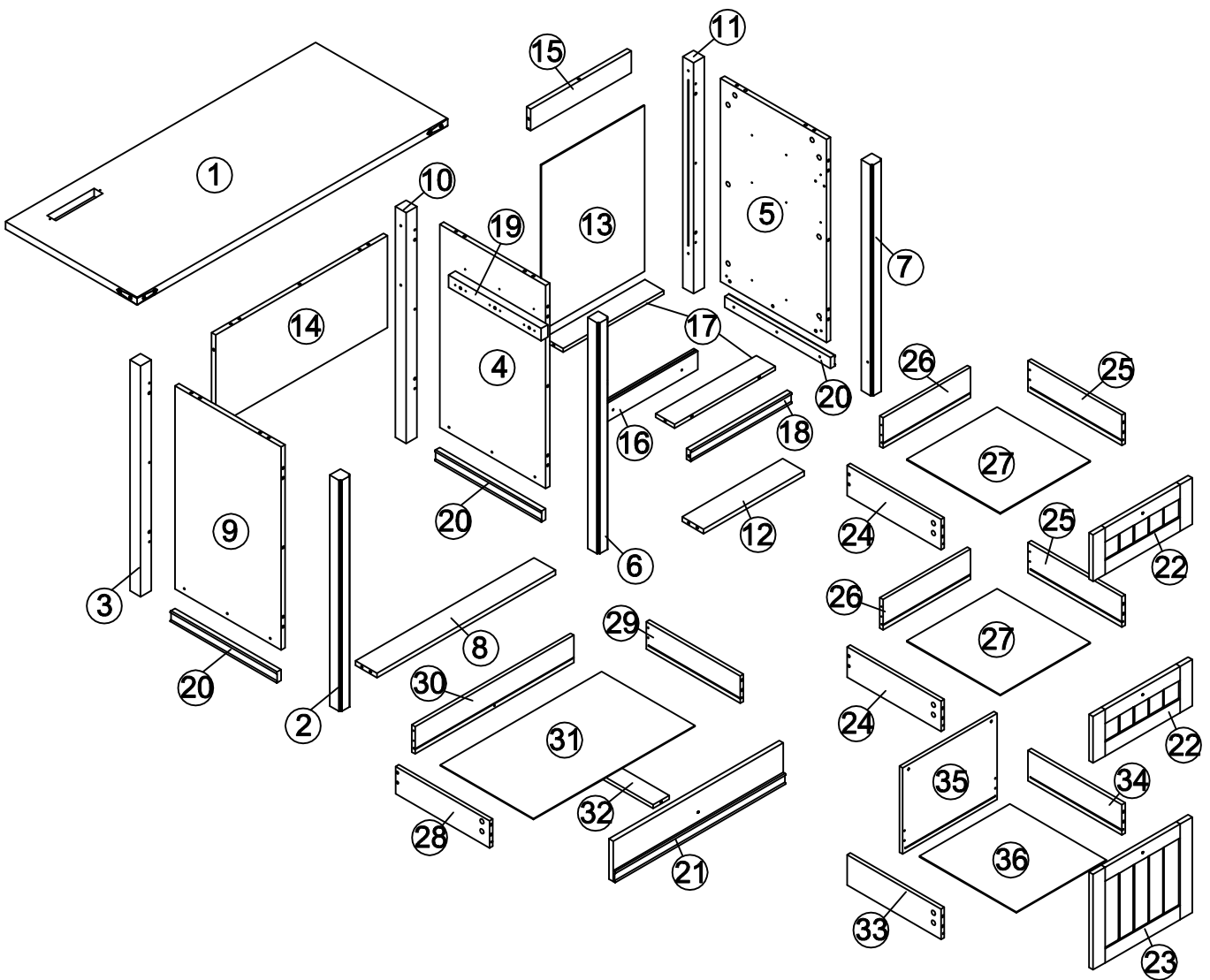

Part List

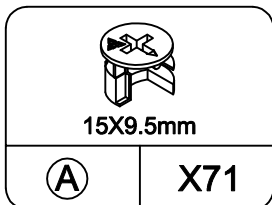

CAM LOCK
spare:3

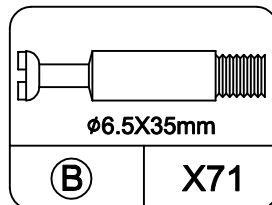

CAM BOLT
spare:3

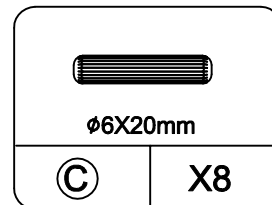

WOOD DOWEL
spare:1

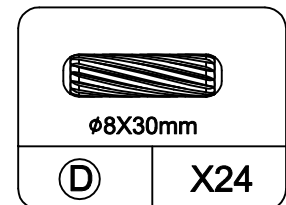

WOOD DOWEL
spare:2

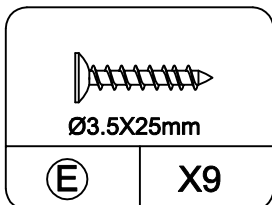

SCREW
spare:1

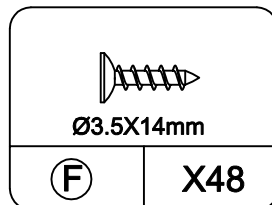

SCREW
spare:3

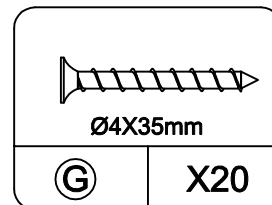

SCREW
spare:2

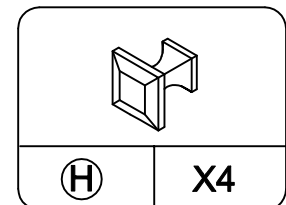

HANDLE

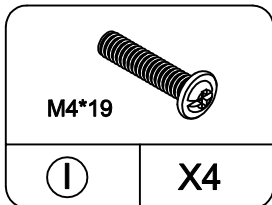

SCREW
spare:1

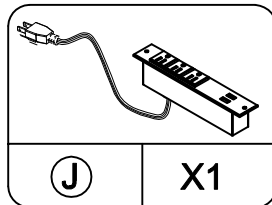

PLUG BOARD

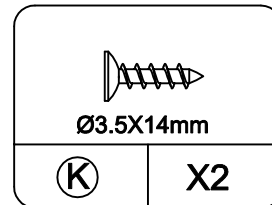

SCREW
spare:1

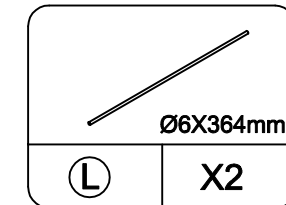

HANDLE

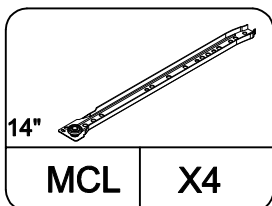

LEFT CABINET MEMBER

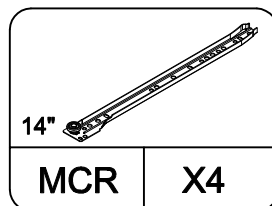

RIGHT CABINET MEMBER

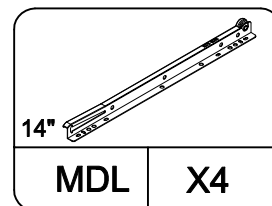

LEFT DRAWER RUNNER

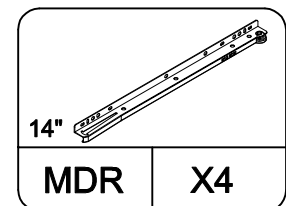

RIGHT DRAWER RUNNER

Insert the cam bolt into the hole first, then insert the cam lock and lock it.

Cam Lock Fastening System

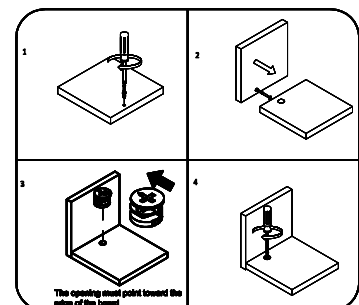

STEP 1

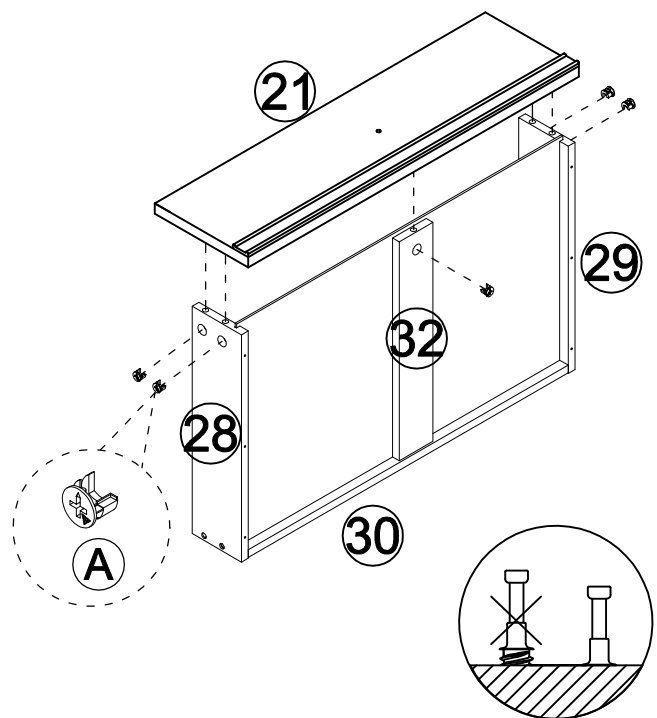
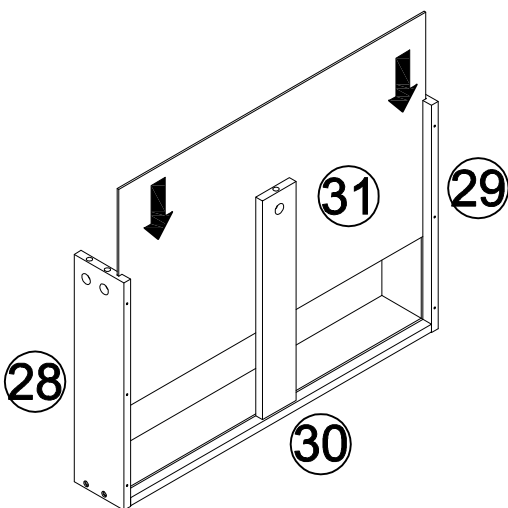
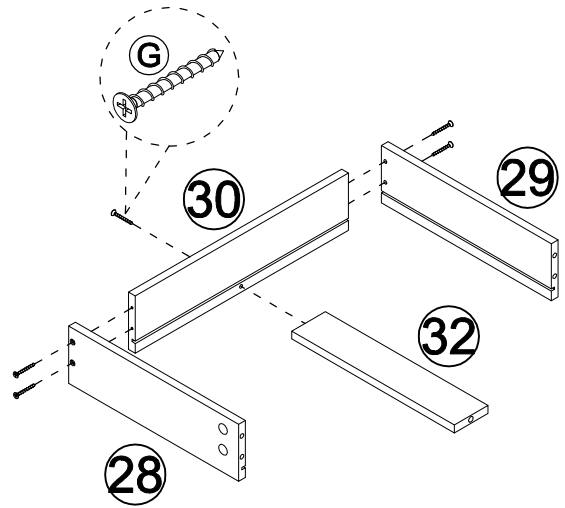
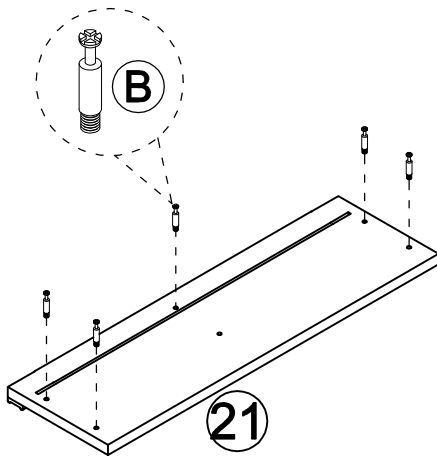
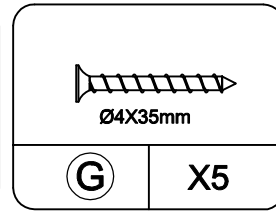
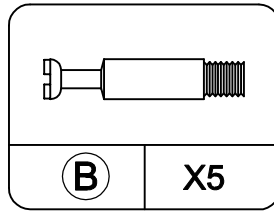
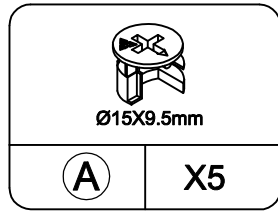
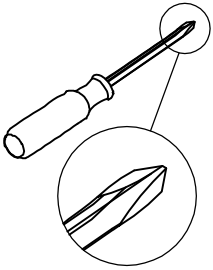

Proper orientation of CAM LOCK

STEP 2

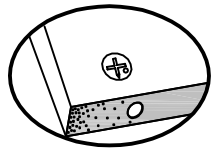
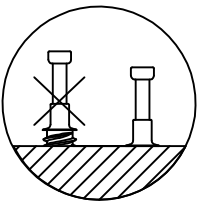
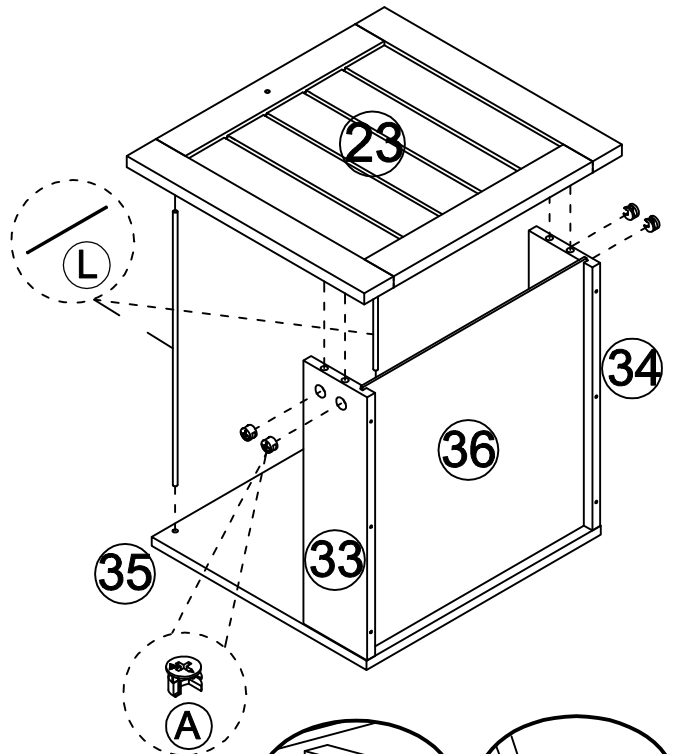
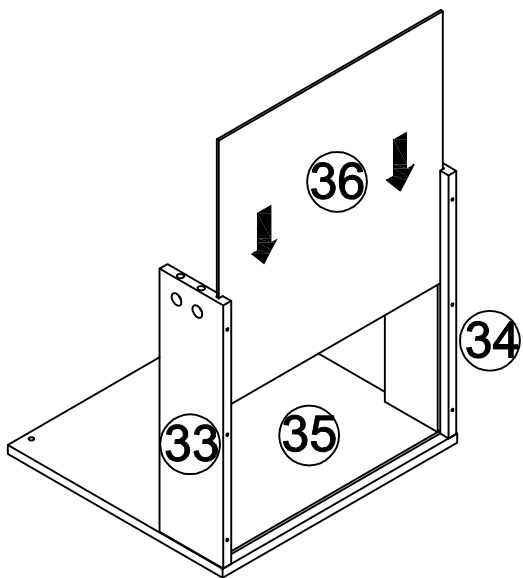
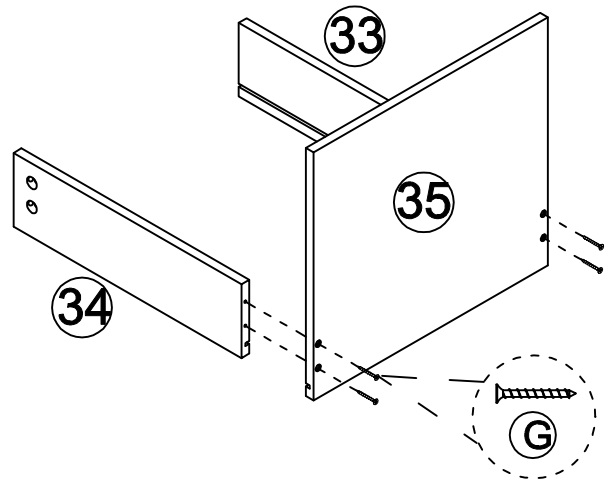
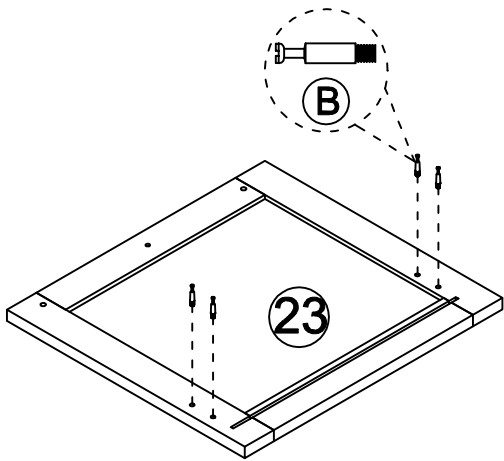
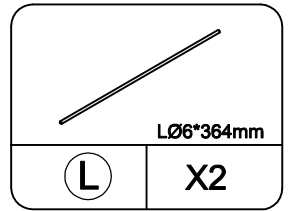
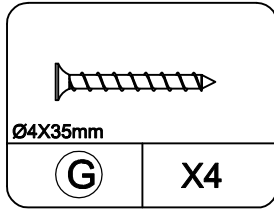
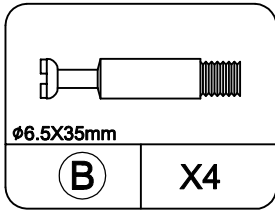
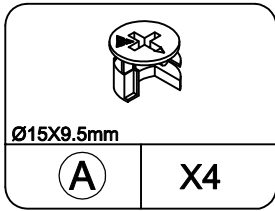
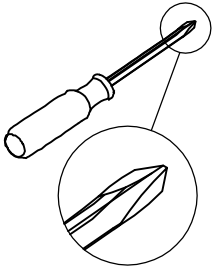

Proper orientation of CAM LOCK

STEP 3

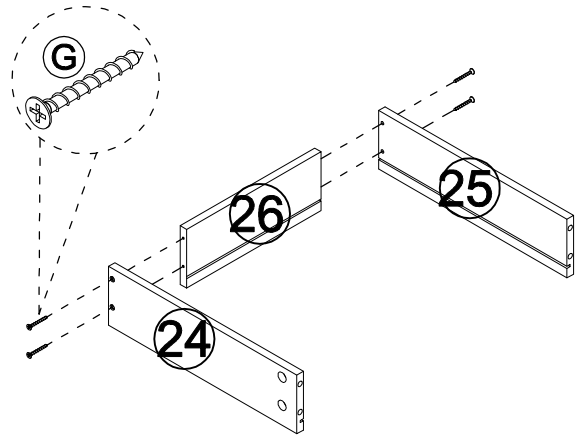
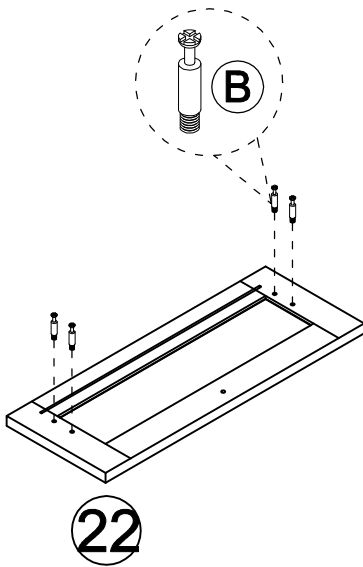
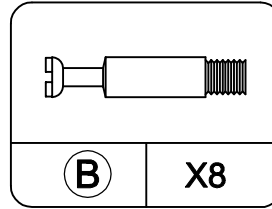
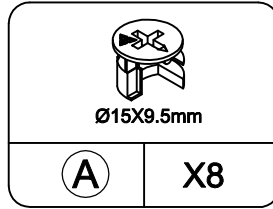
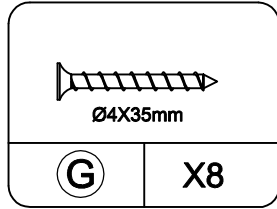
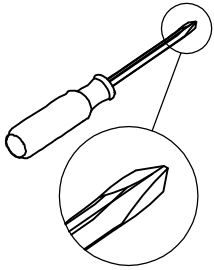

X 2

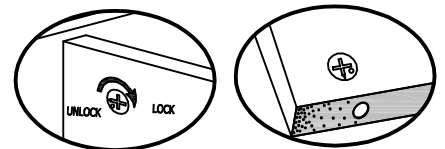
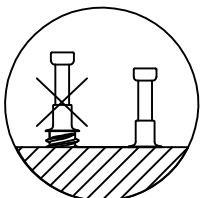
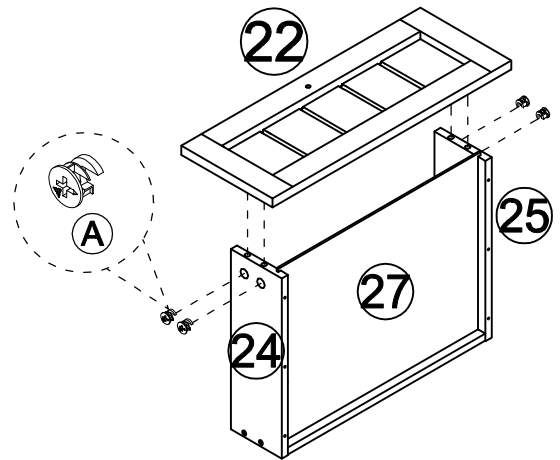
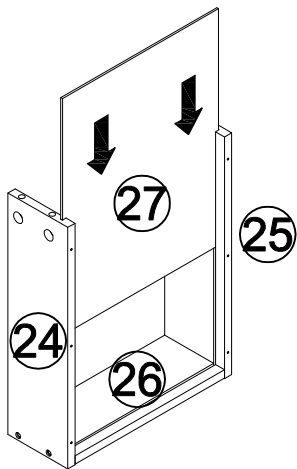

Proper orientation of CAM LOCK

STEP 4

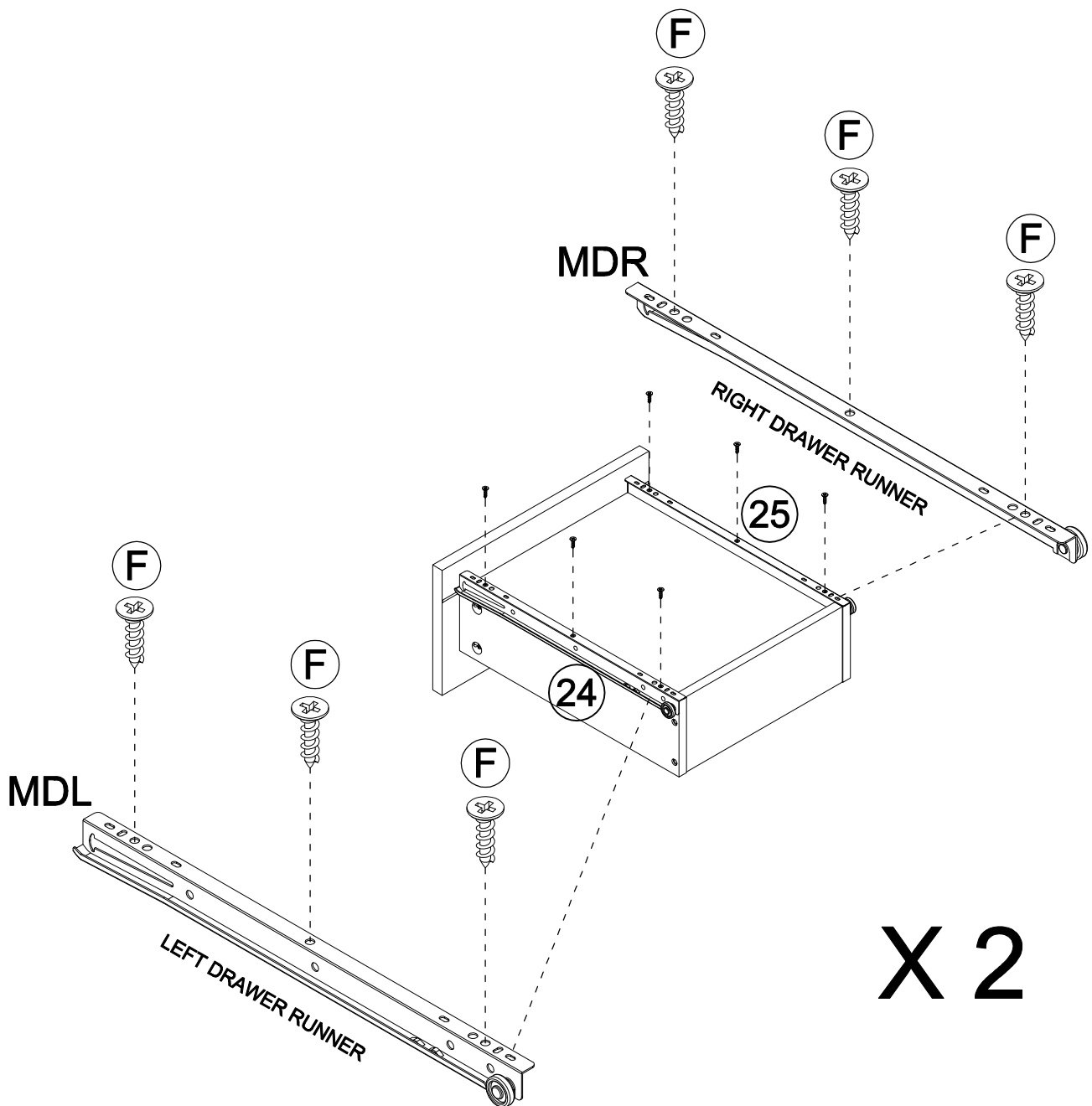
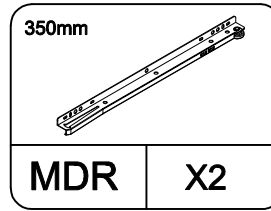
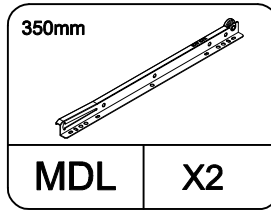
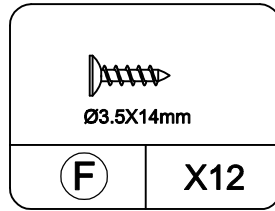
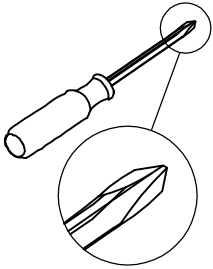

X 2

STEP5

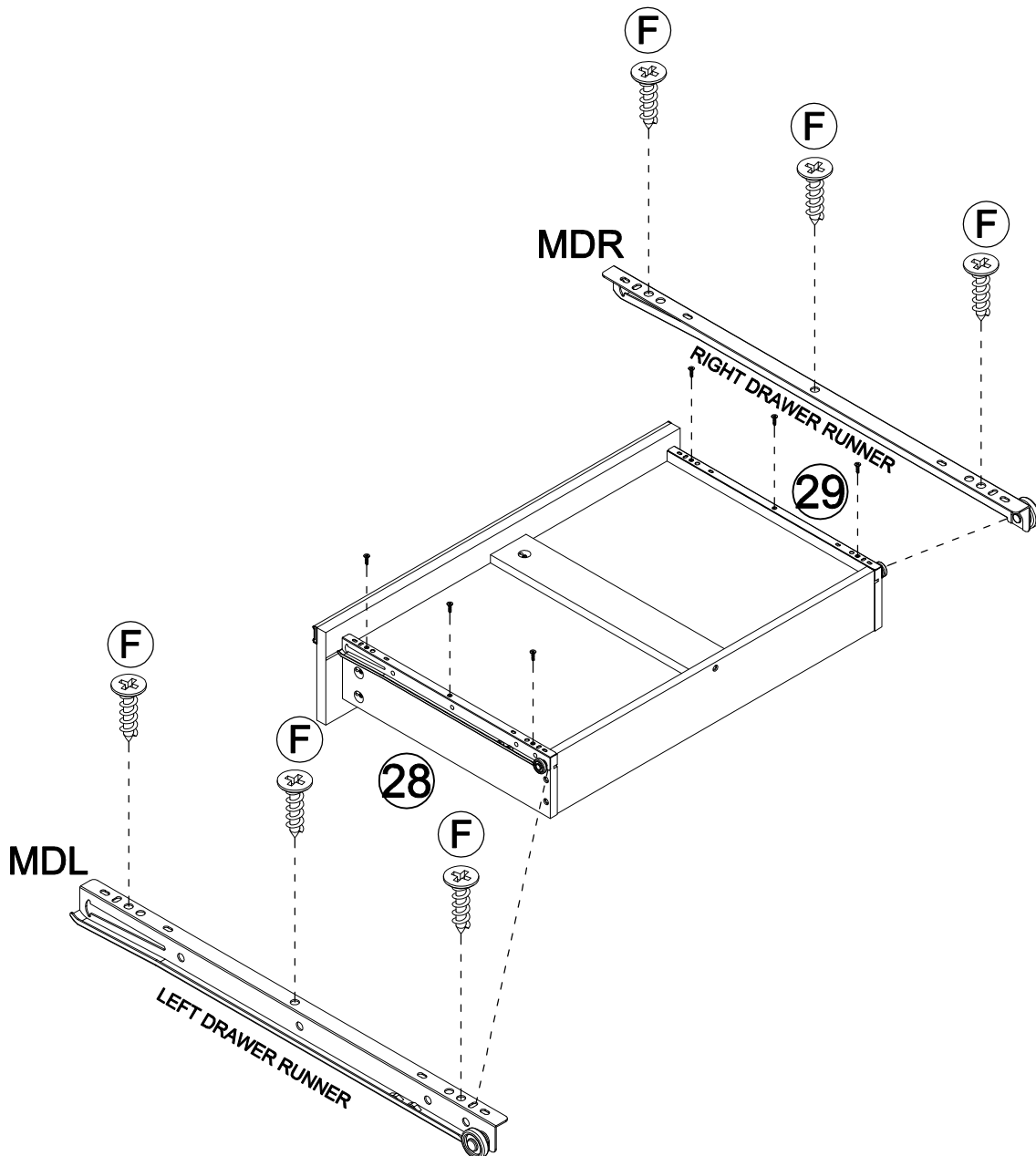
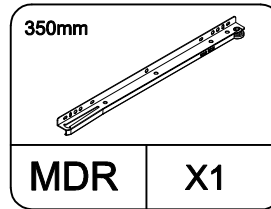
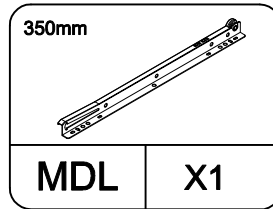
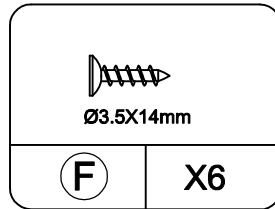
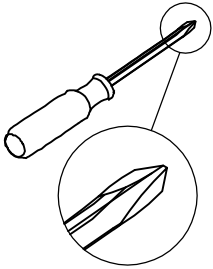

STEP 6

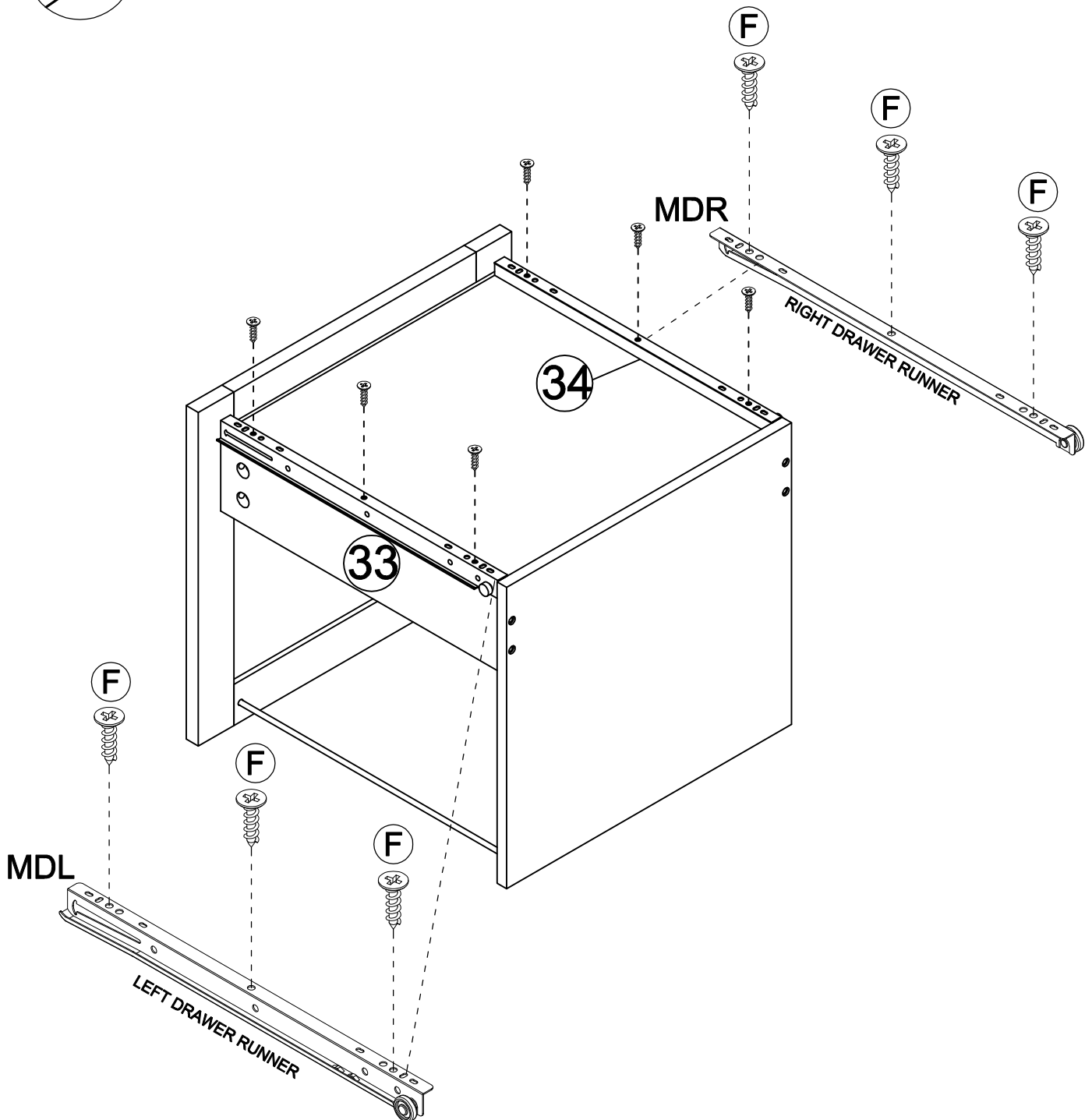
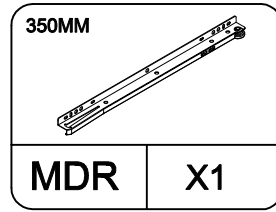
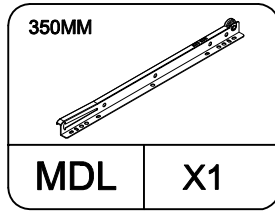
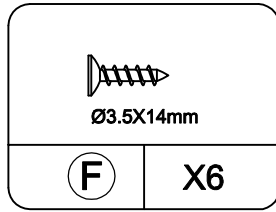
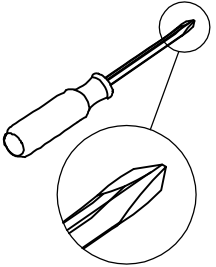

STEP 7

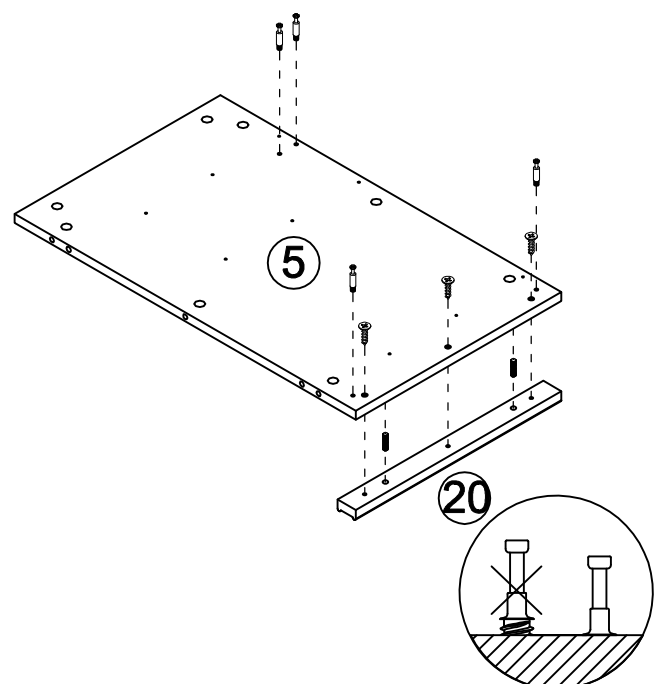
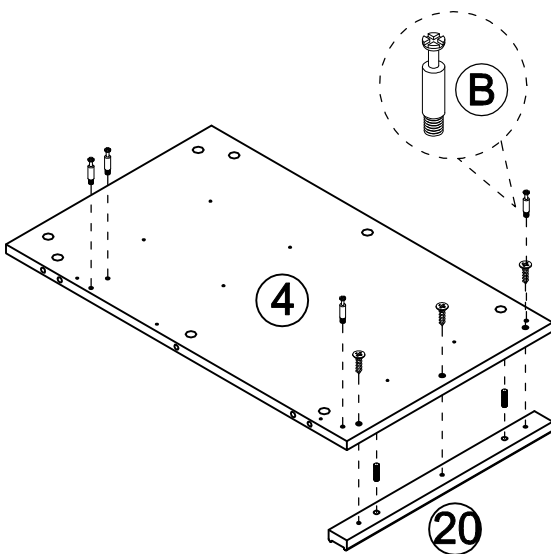
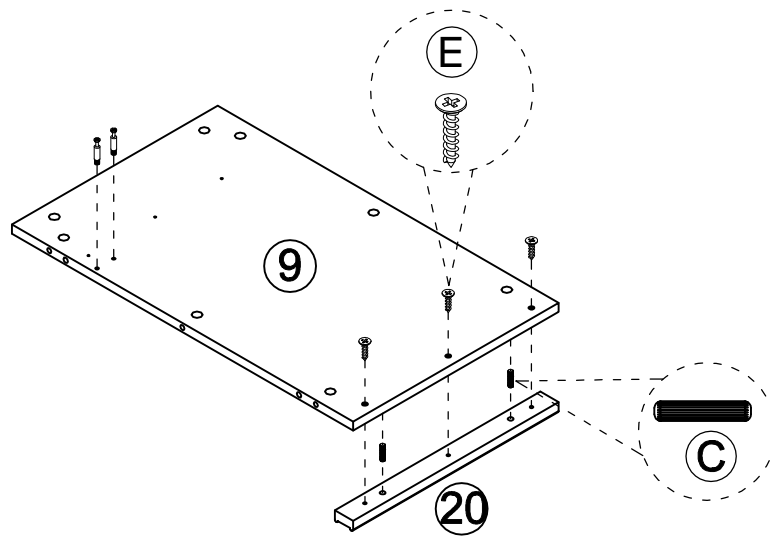
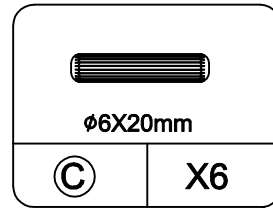
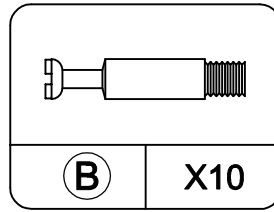
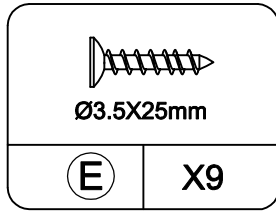
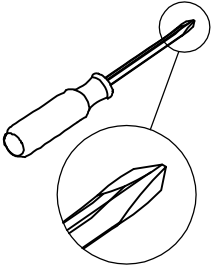

STEP 8

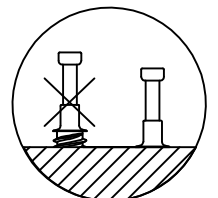
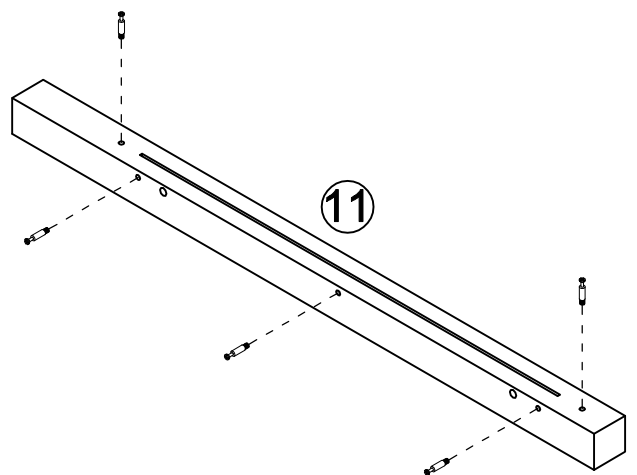
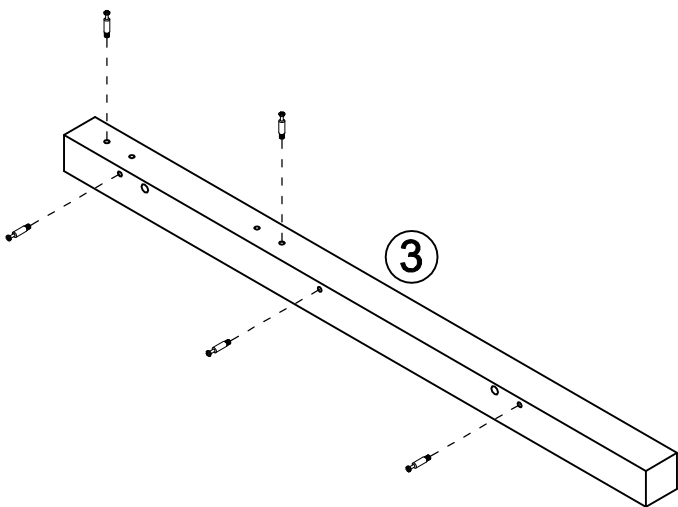
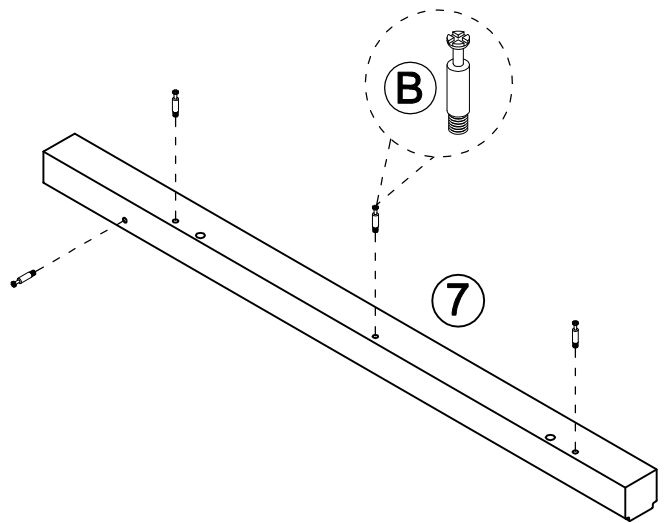
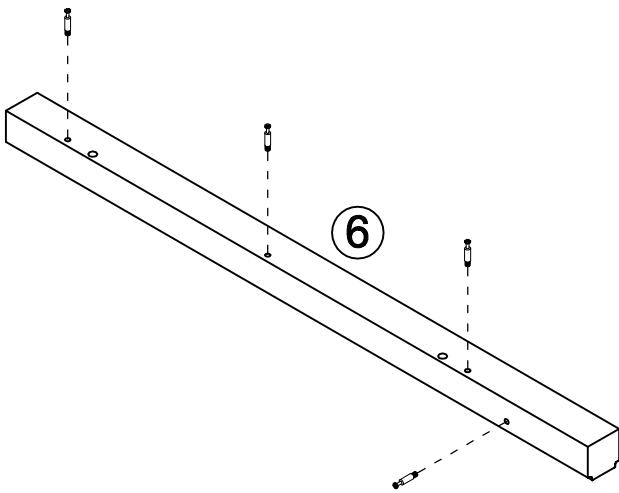
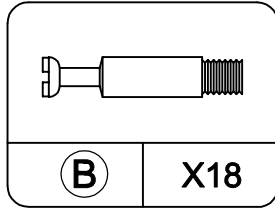
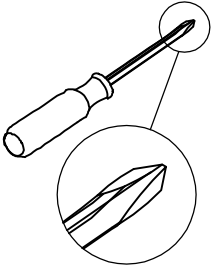

STEP 9

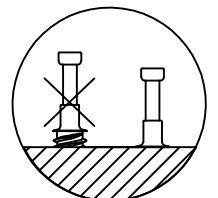
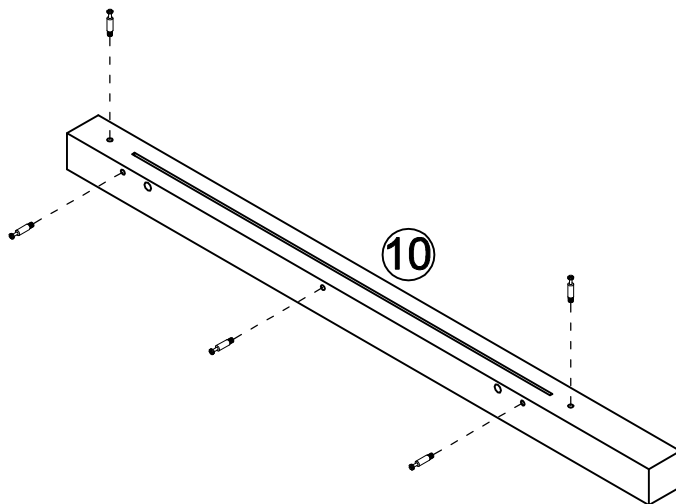
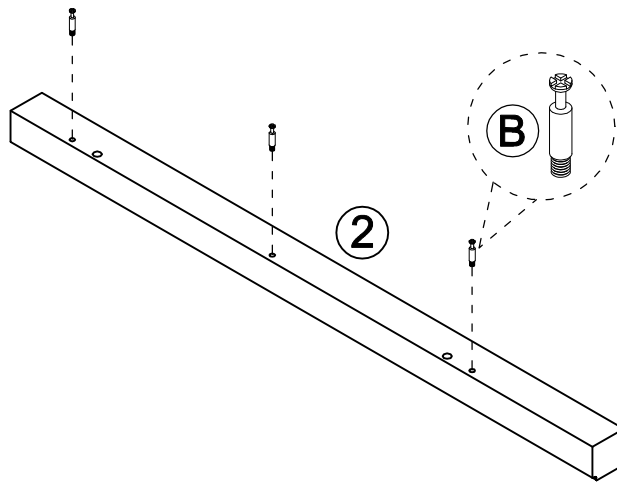
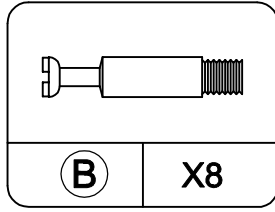
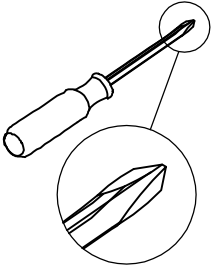

STEP 10

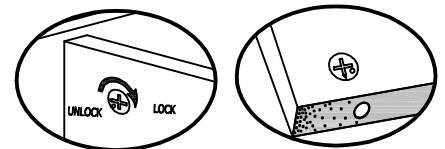
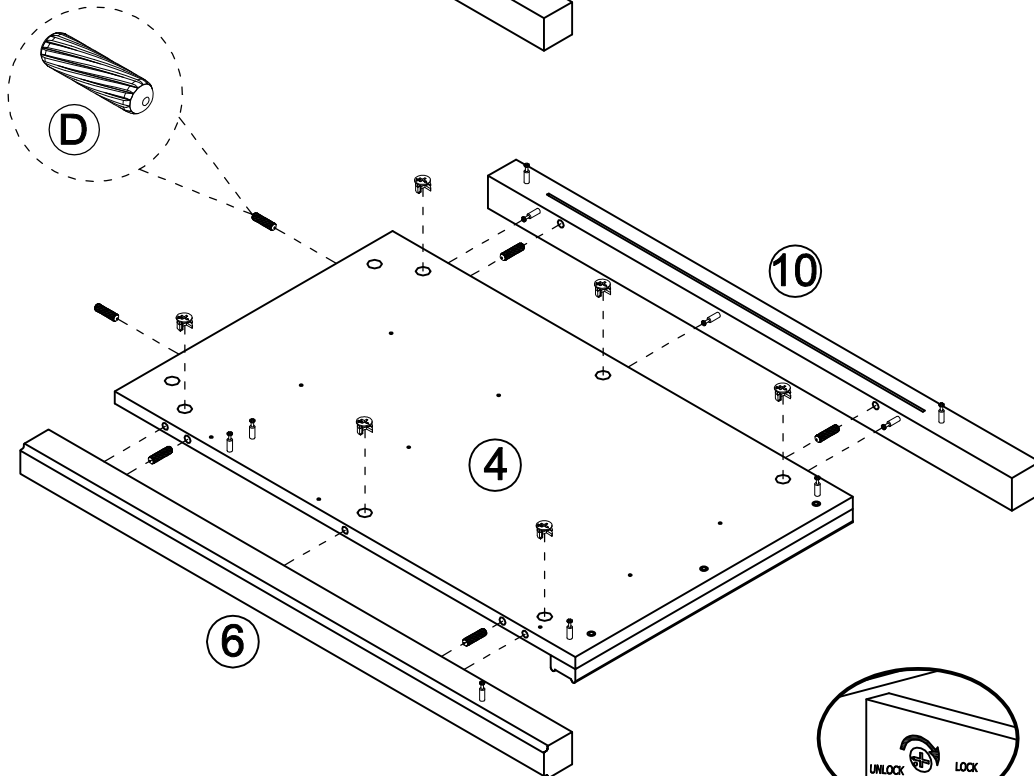
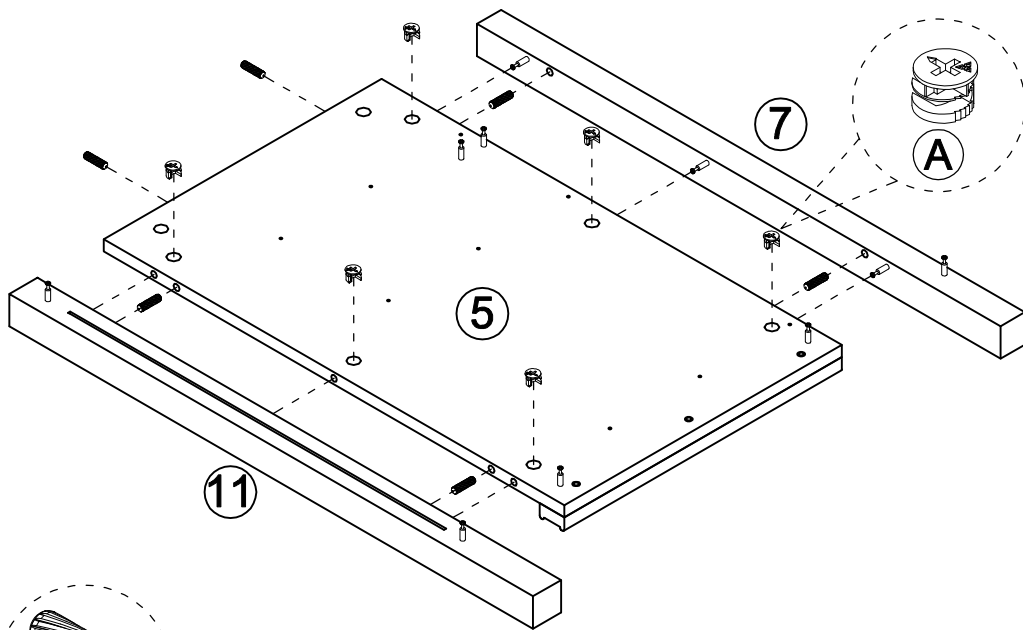
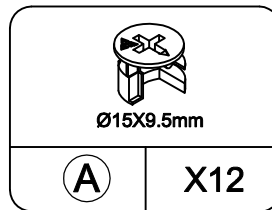
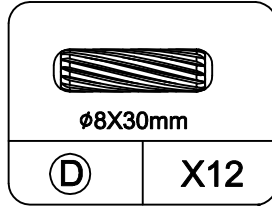
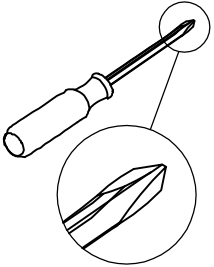

Proper orientation of CAM LOCK

STEP 11

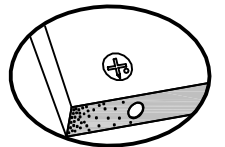
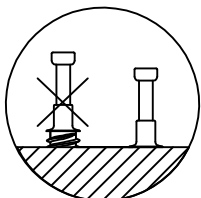
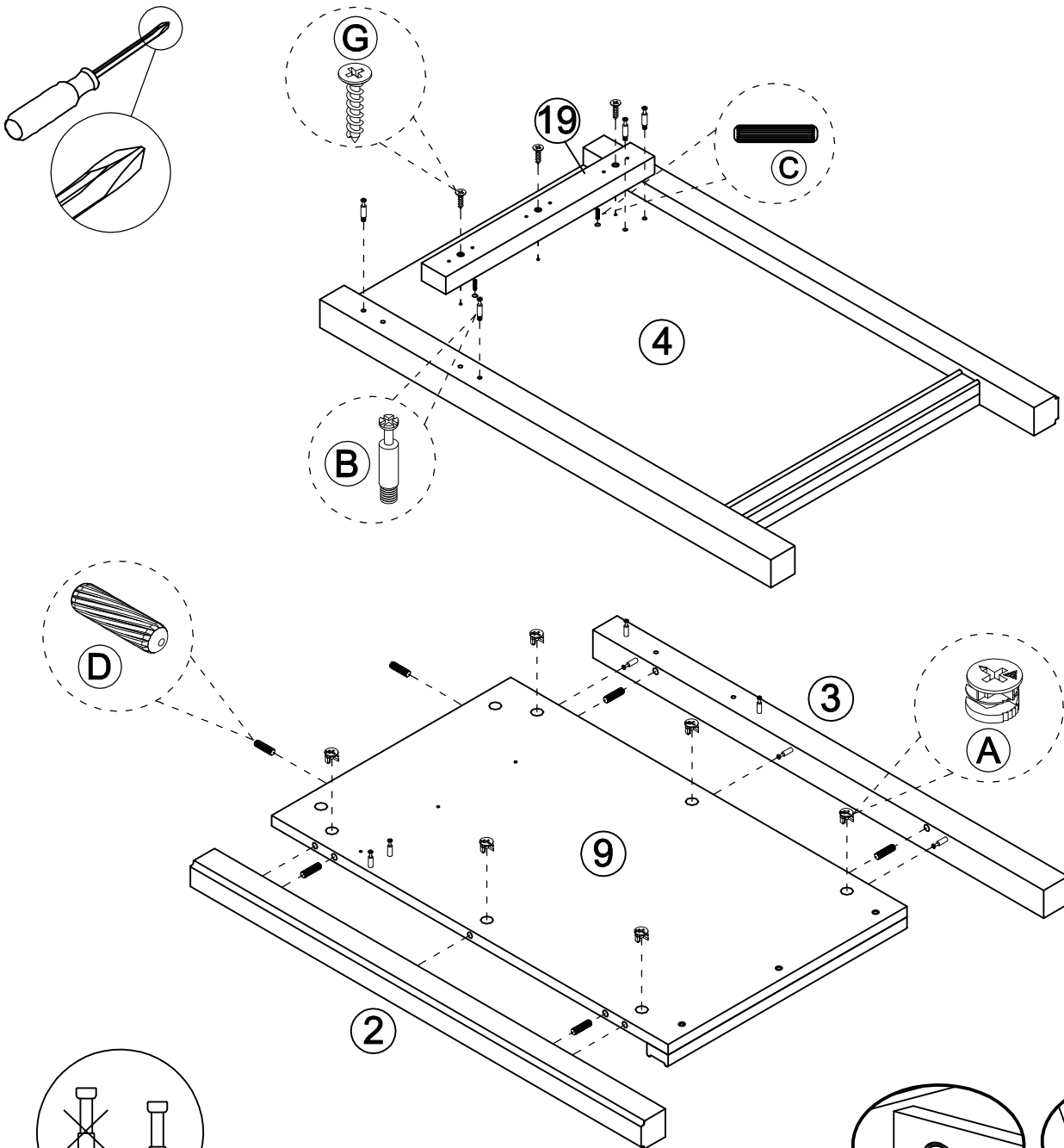
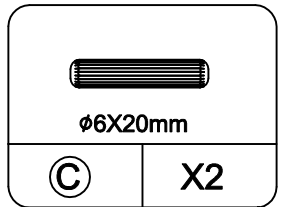
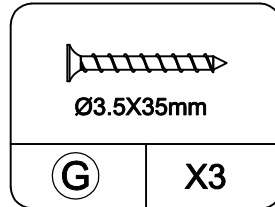
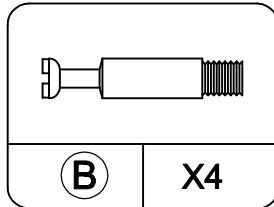
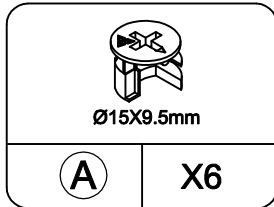
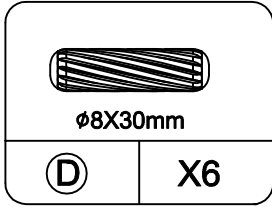

Proper orientation of CAM LOCK

STEP 12

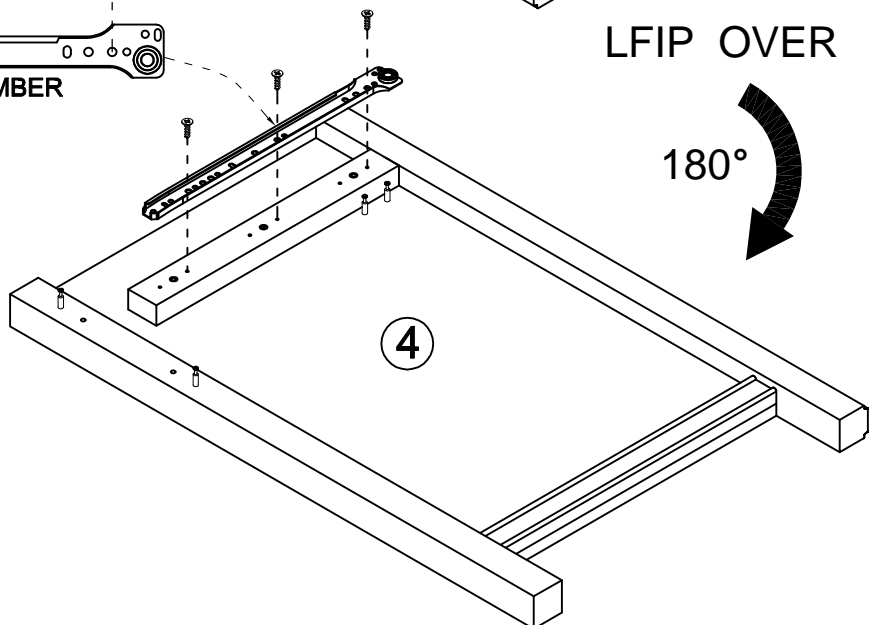
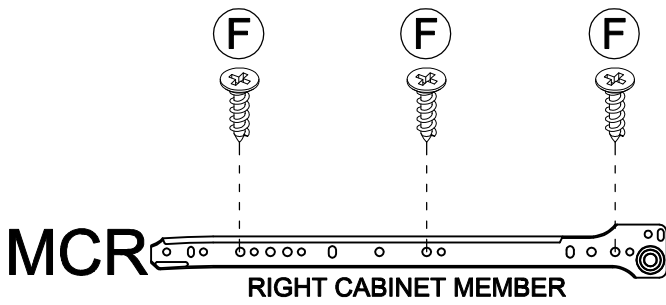
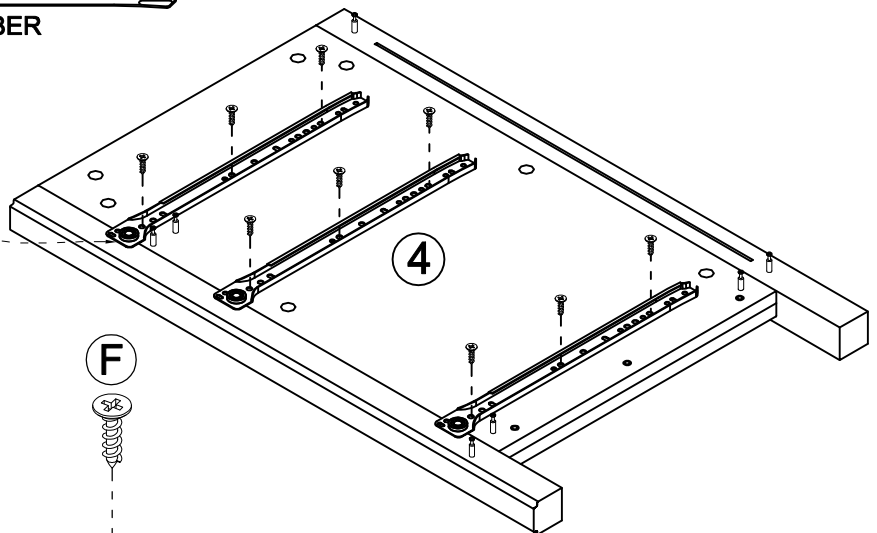
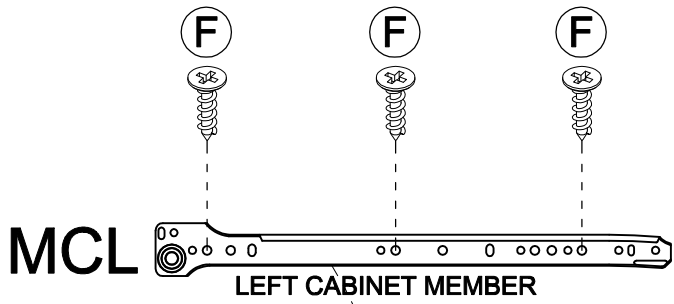
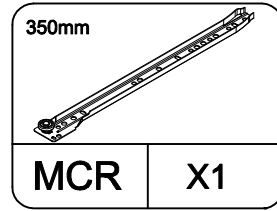
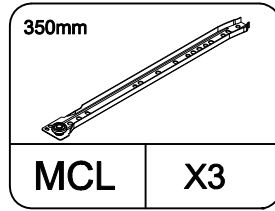
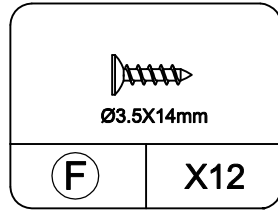
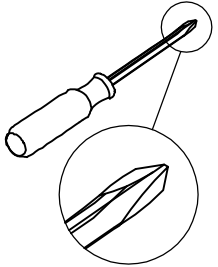

STEP 13

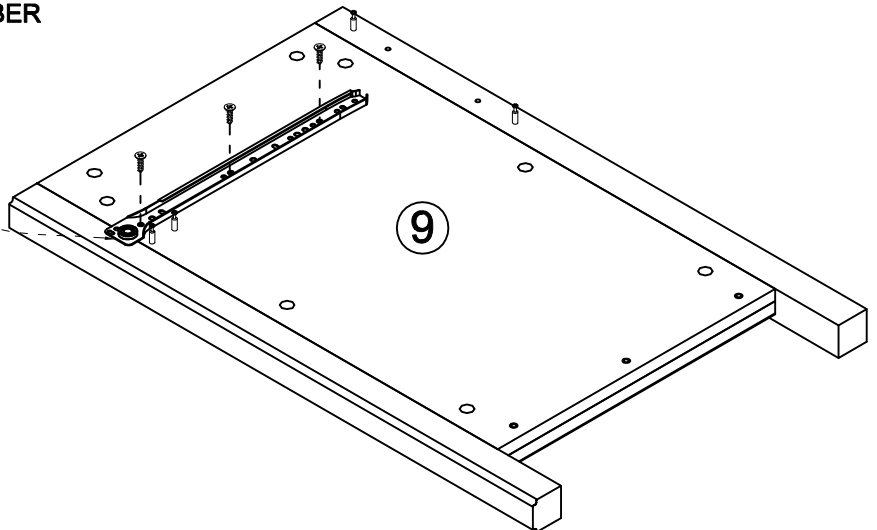
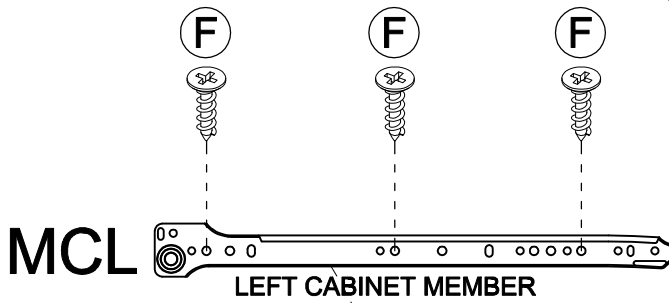
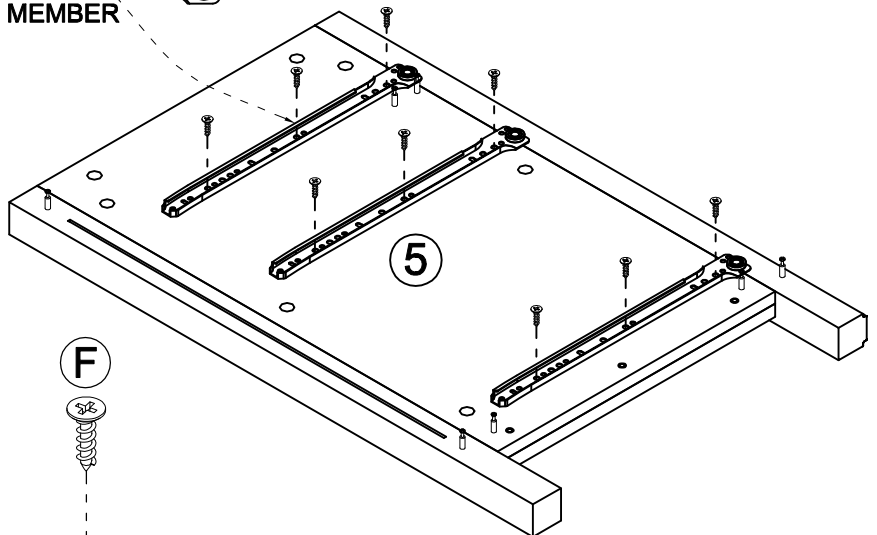
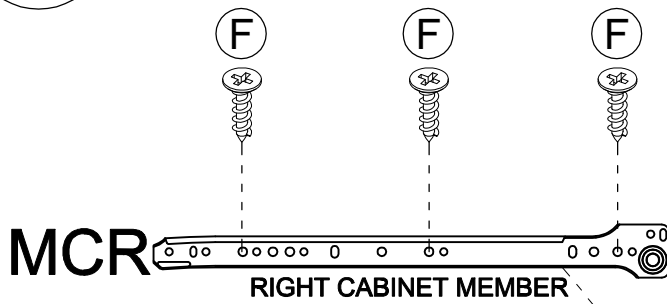
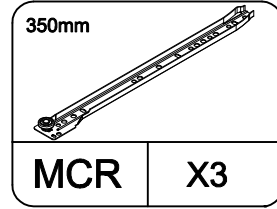
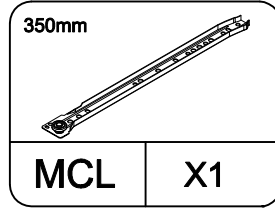
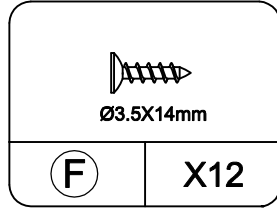
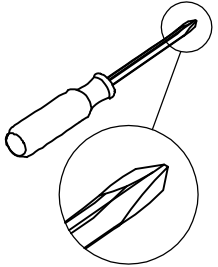

STEP 14

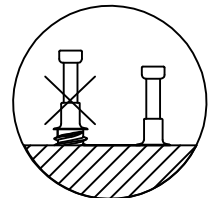
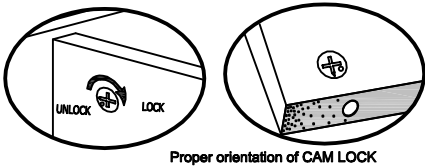
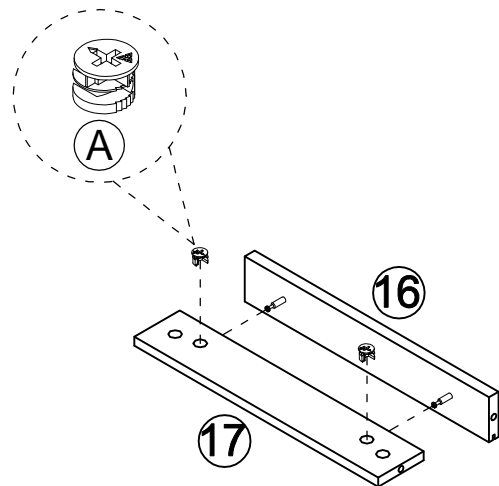
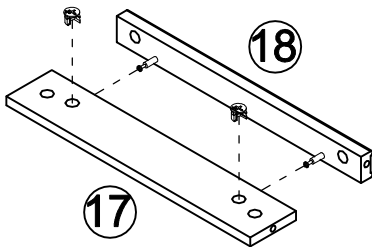
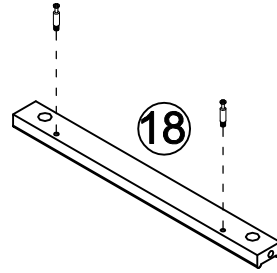
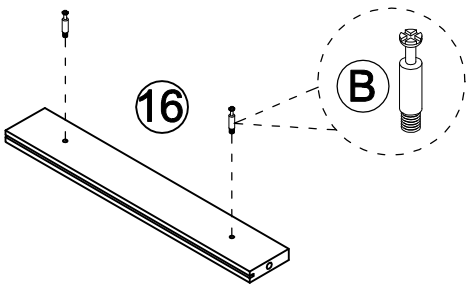
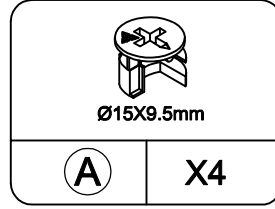
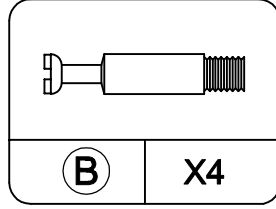
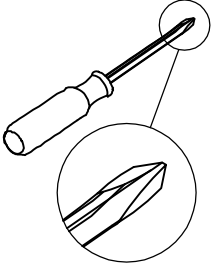

STEP 15

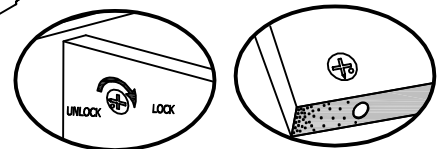
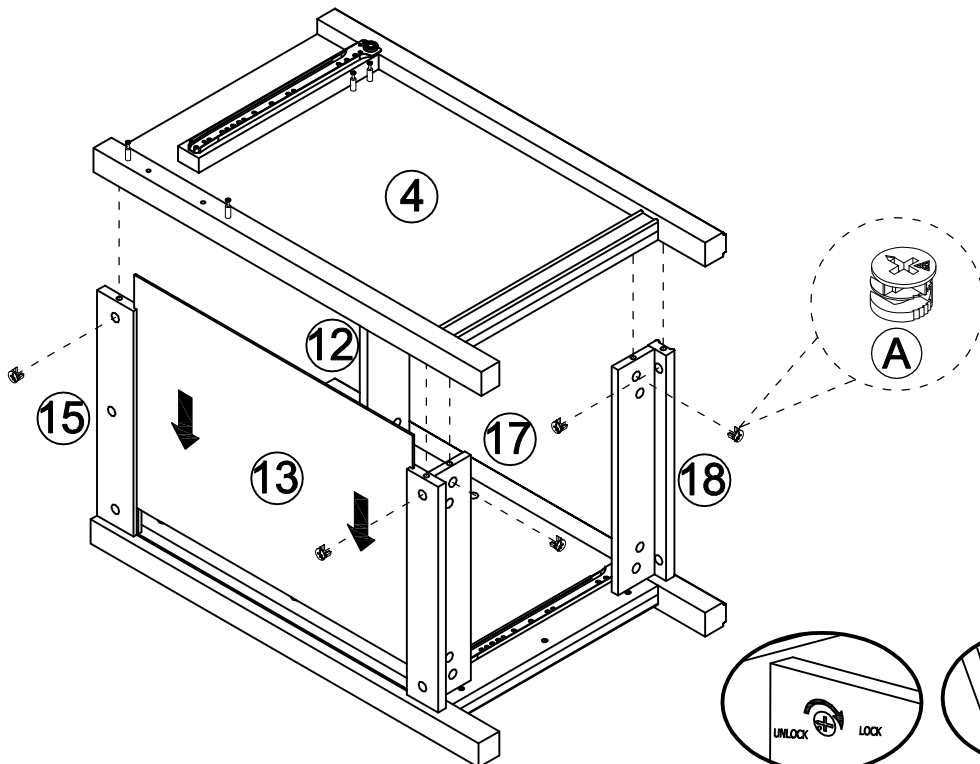
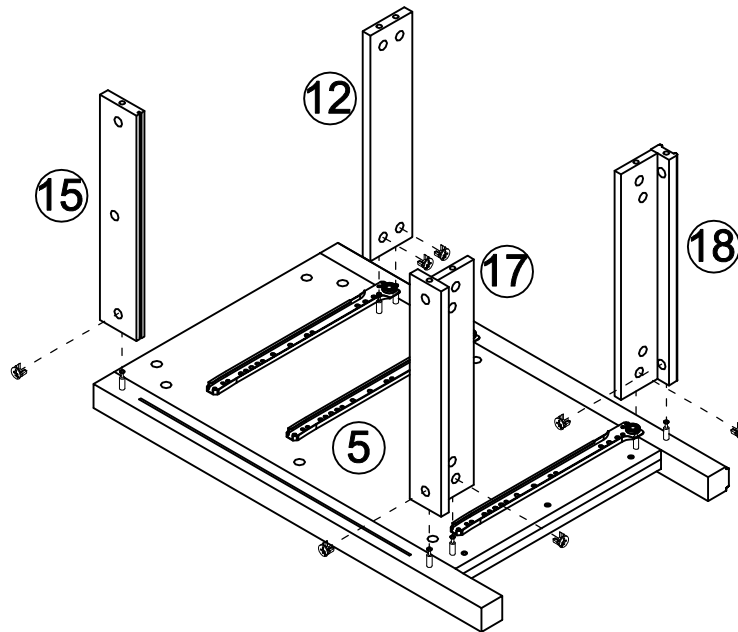
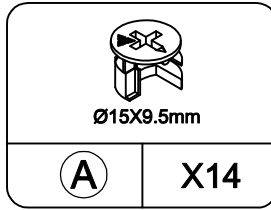
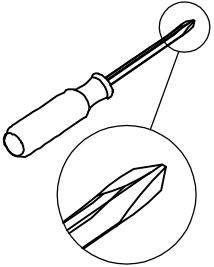

Proper orientation of CAM LOCK

STEP 16

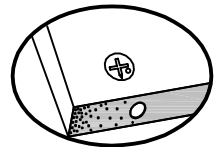
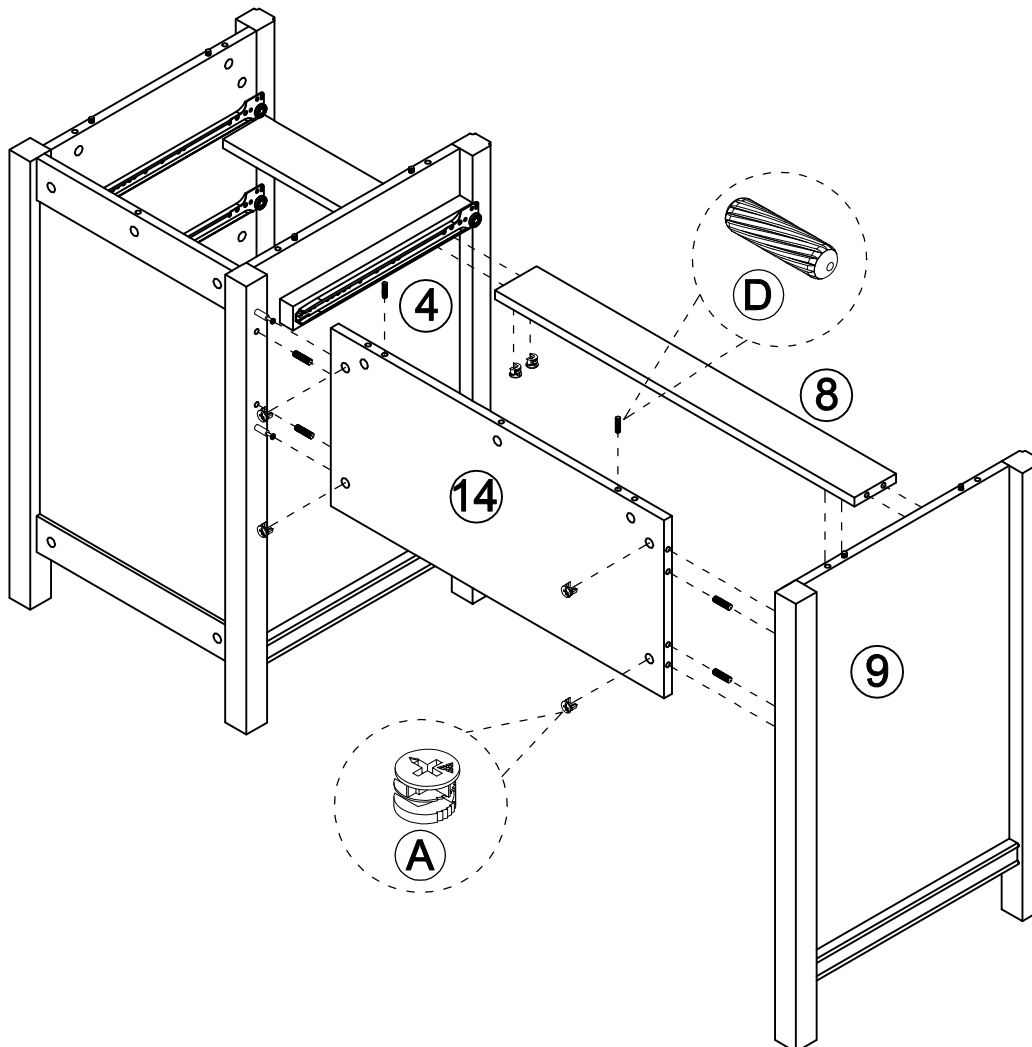
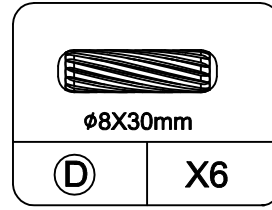
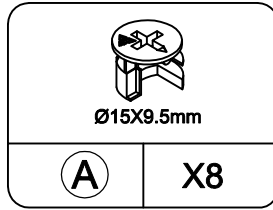
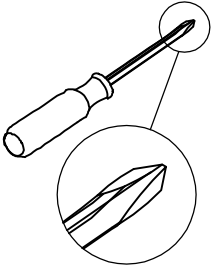

Proper orientation of CAM LOCK

STEP 17

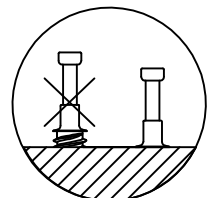
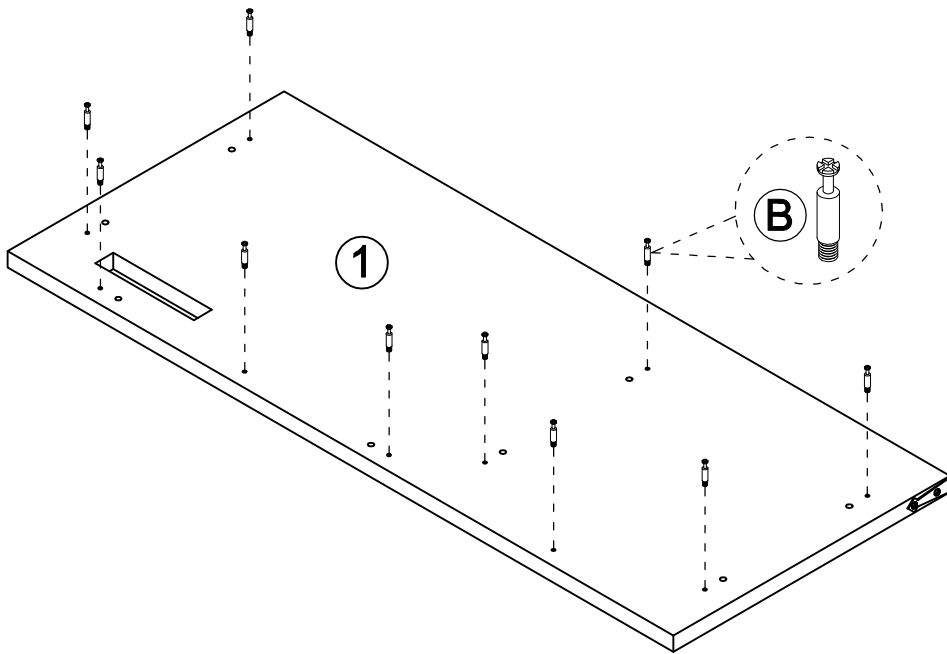
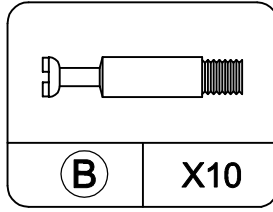
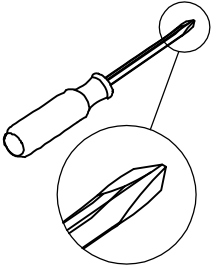

STEP 18

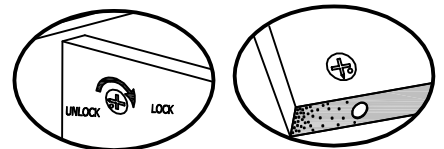
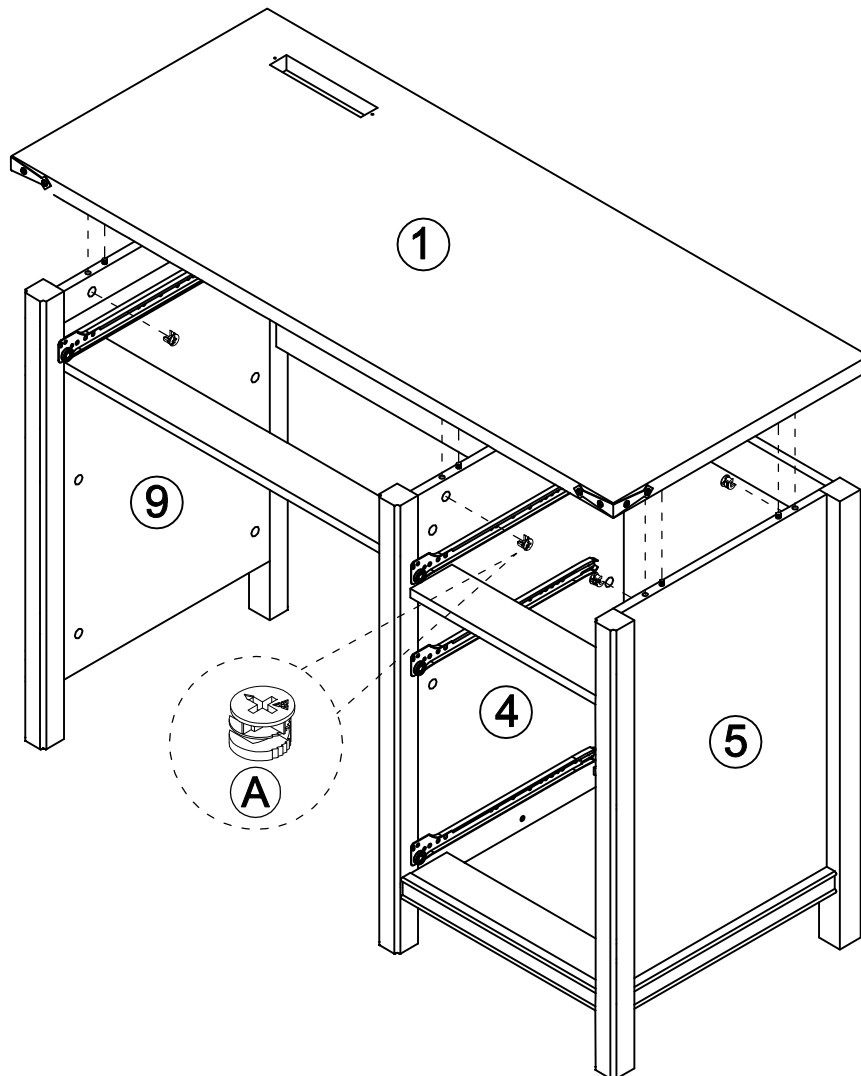
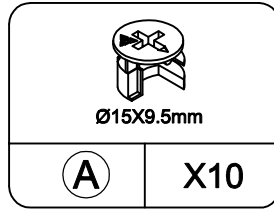
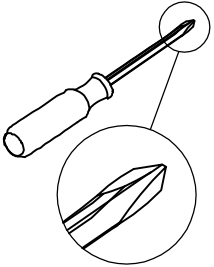

Proper orientation of CAM LOCK

STEP 19

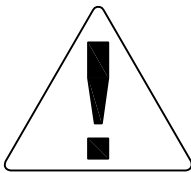
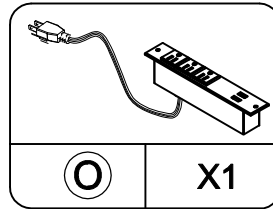
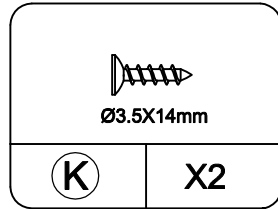
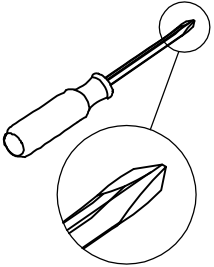

**The power of using
electrical appliances
cannot exceed 1500W**

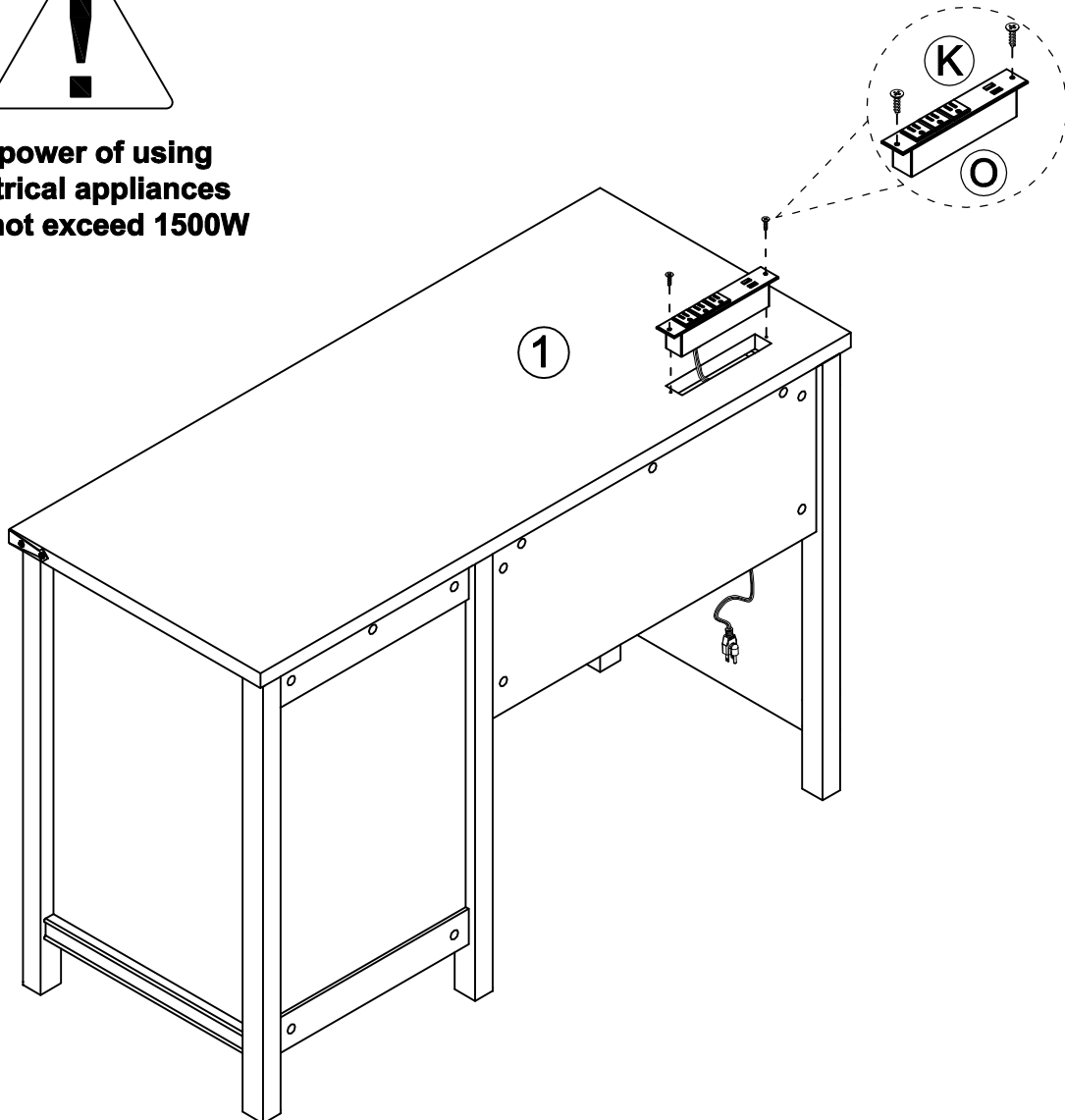

STEP 20

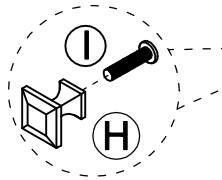
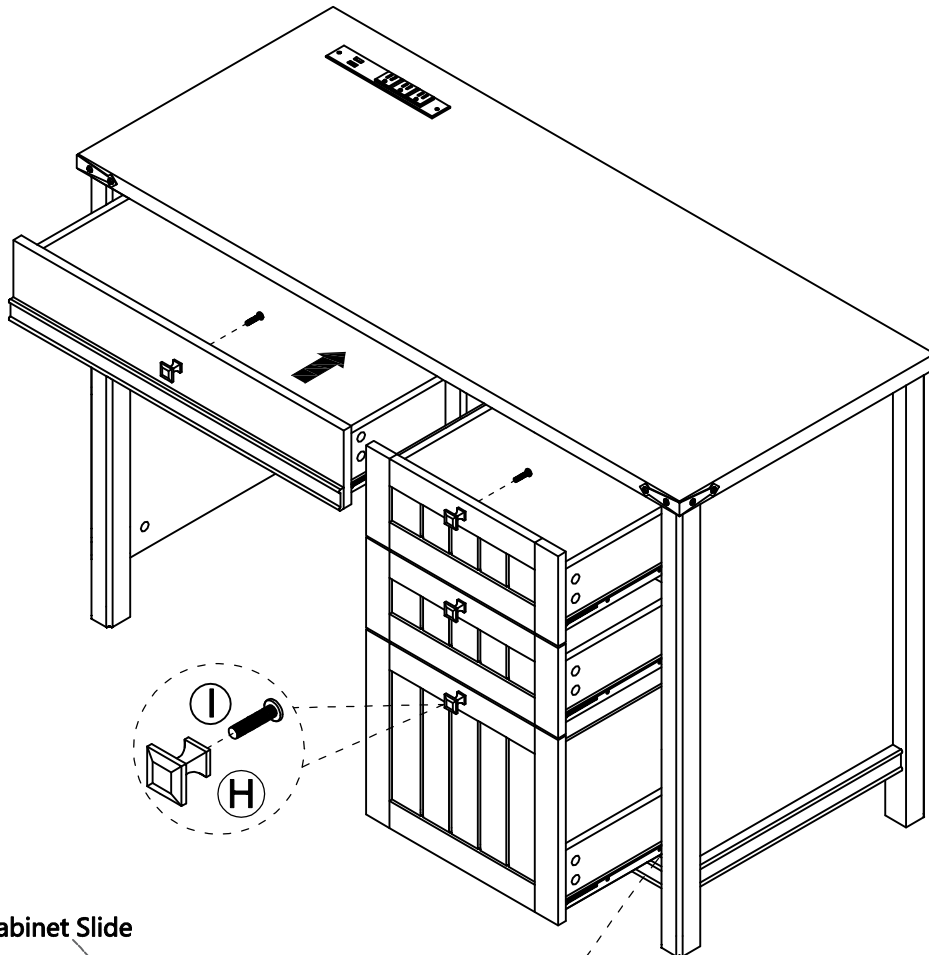
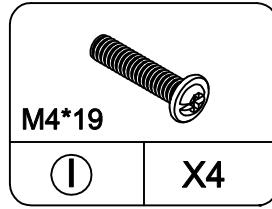
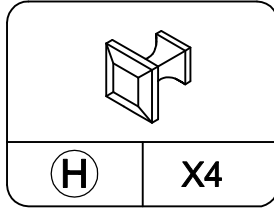
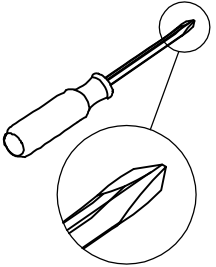

Cabinet Slide

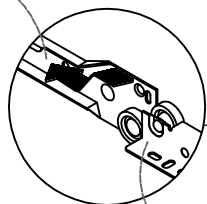

Drawer Slide