

Installation instructions

Input voltage: 110-120V/220-240V 50/60Hz

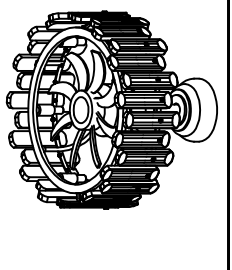
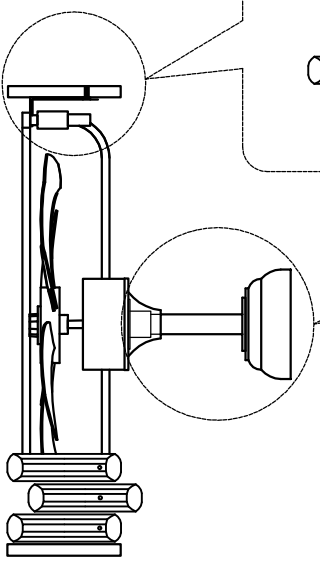
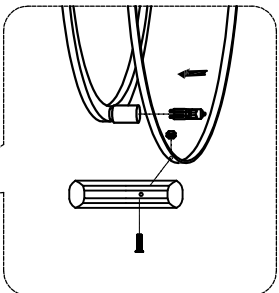
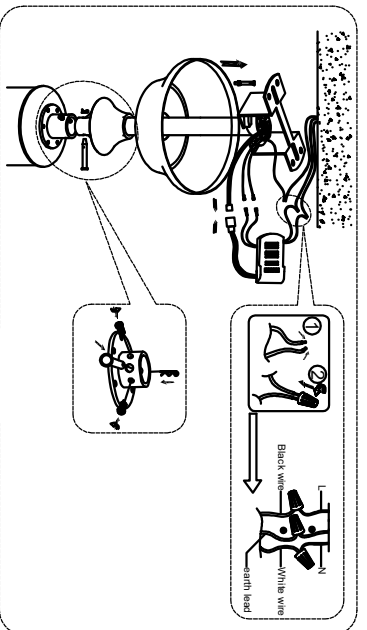
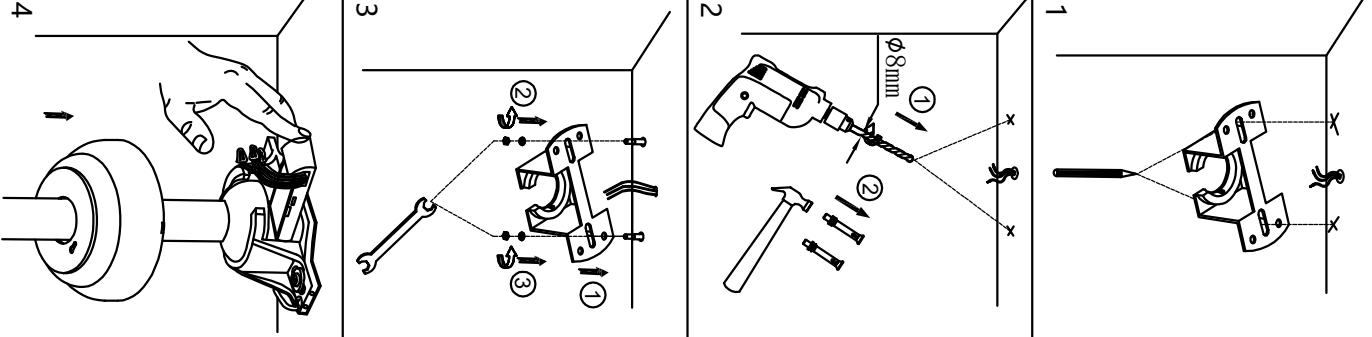

Note:

1. Open the packaging and check if the lighting fixtures are intact. The lighting fixtures and accessories should be complete and free of mechanical damage, deformation, paint peeling, and lampshade breakage. If you have any questions, please contact customer service promptly.
2. Before installing the lighting fixtures, a power on test should be conducted to confirm that they can light up.
3. Check if the place where the lamp is hung can withstand the weight of the lamp.
4. Please turn off the power before installation. For the quality and safety of the lamp, please have a professional electrician operate it.
5. Please do not exceed the range specified by the lighting fixture for the power supply used.

Tools:

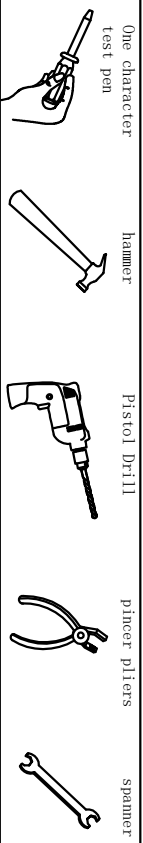

Installation steps:

1. Drill the holes corresponding to the expansion screws on the ceiling.
2. Insert the expansion screw into the hole.
3. Push the lamp body up to the ceiling and connect the power cord correctly.
4. First, fix the lamp body on the ceiling with hanging plate screws and confirm its stability.
5. Turn on the power and test if the lighting fixture can light up.

Note: If it is a wooden ceiling, there is no need for expansion screws. Self tapping screws can be used directly to lock it.

Current range of telephone after-sales service
 Language: English only Country: USA and Canada
 Customers from other countries are advised to contact us via email. AFTER-SALES SERVICE Email: all-support@depuley.com
 AFTER-SALES SERVICE TEL: (888) 985-3006 Depuley
 (888) 986-0020 DLT
 Mon-Fri 9am- 5pm (PST)