

ASSEMBLY INSTRUCTIONS

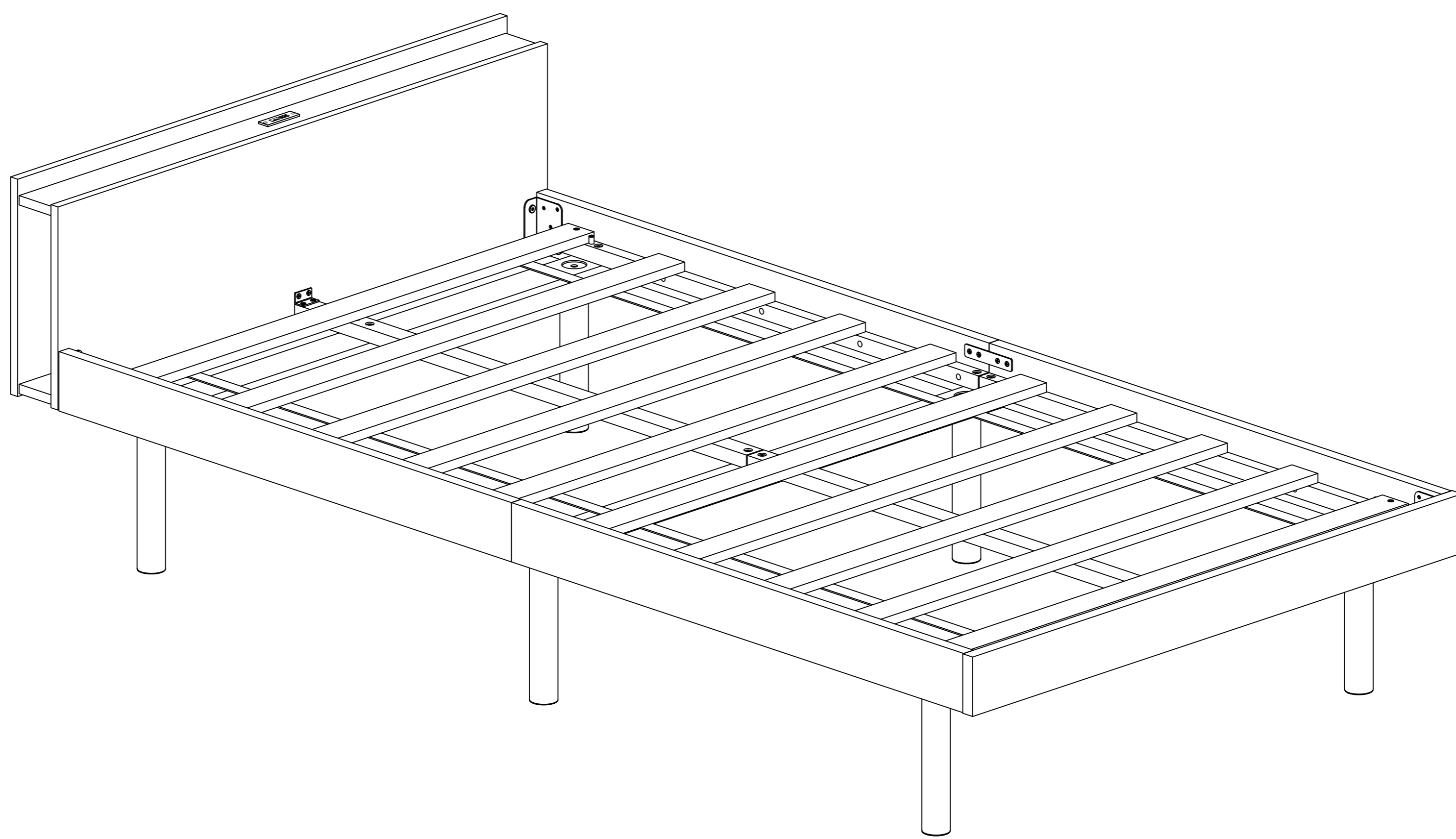

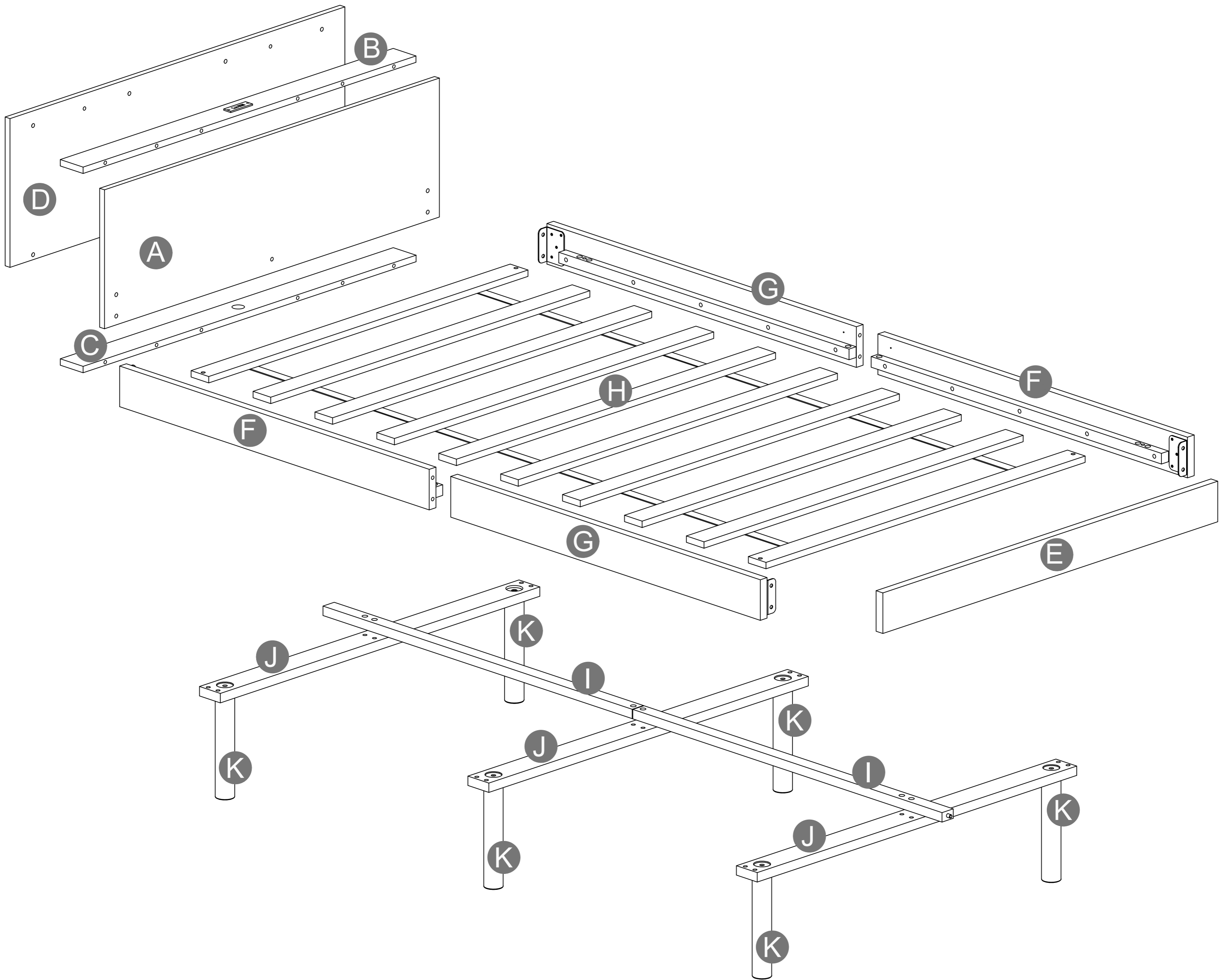

YX7108

Detail View

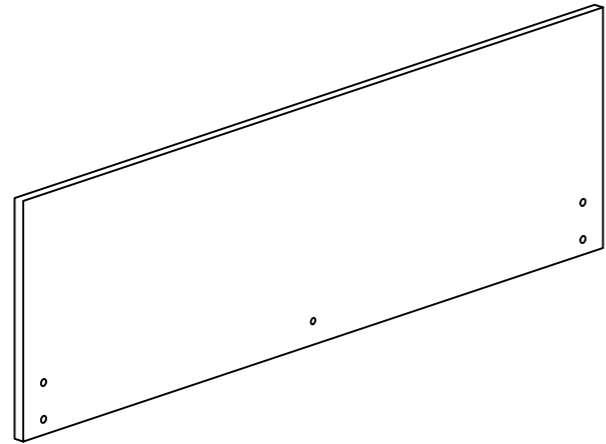
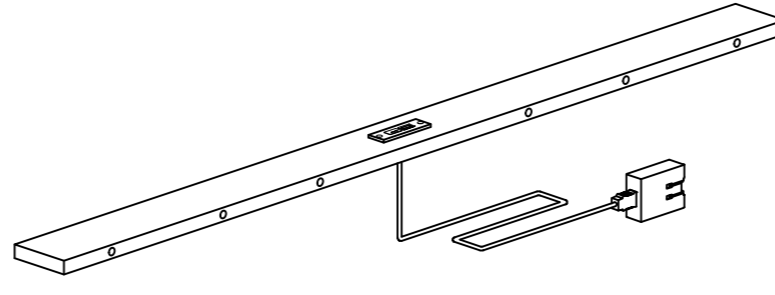
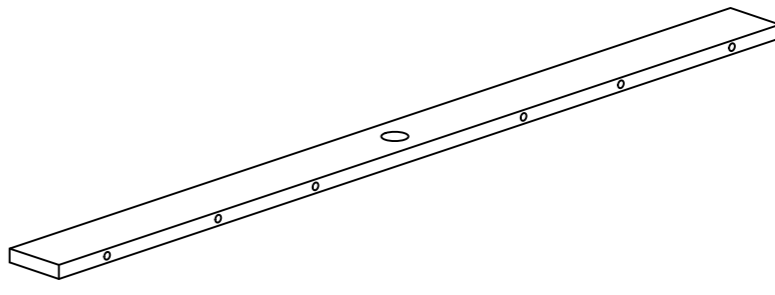
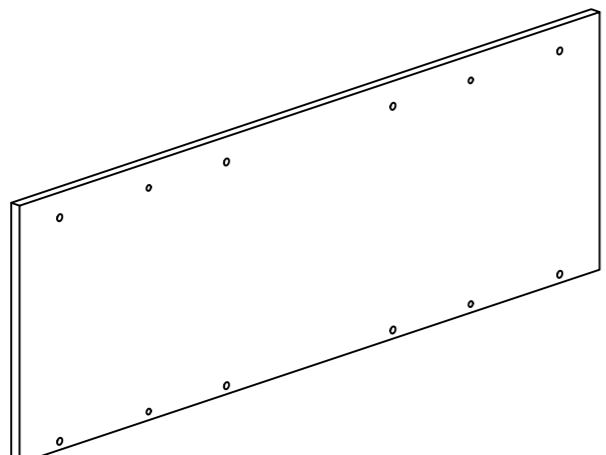
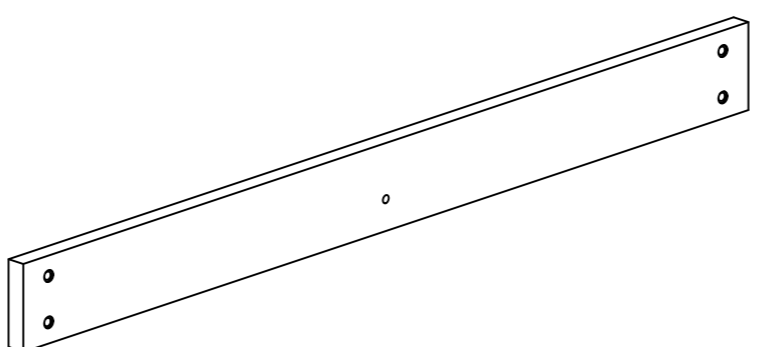
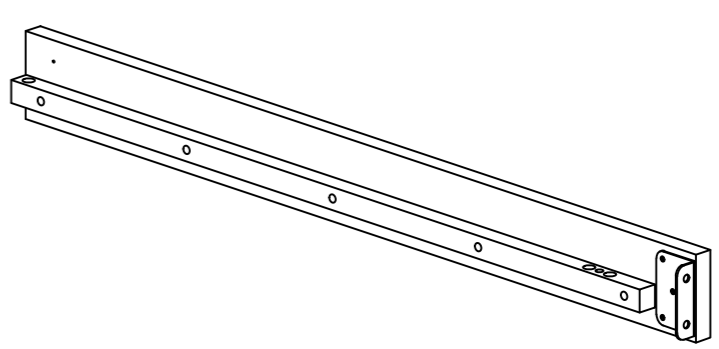
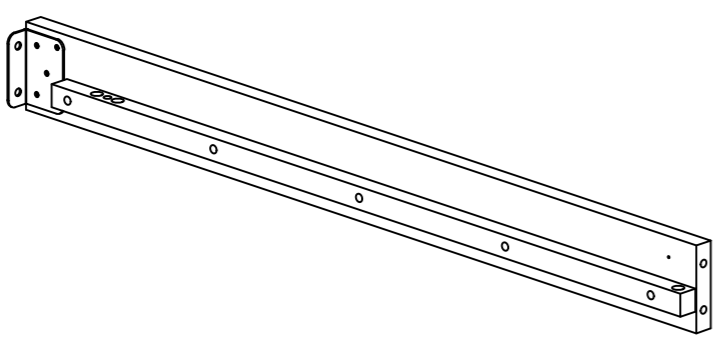
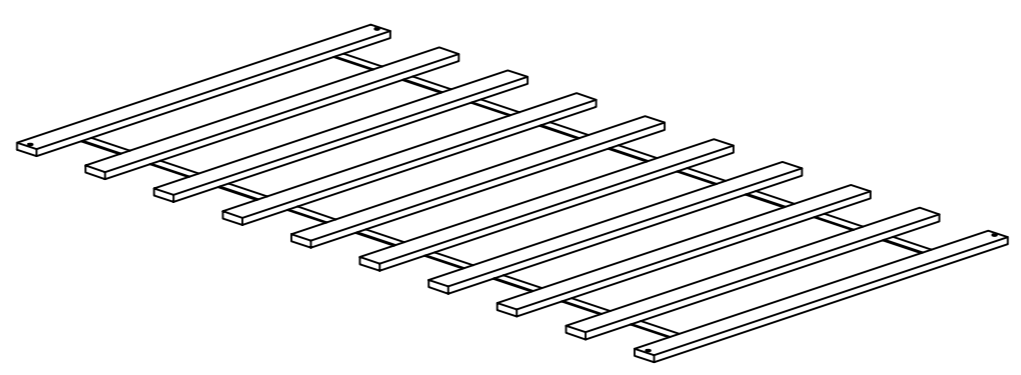
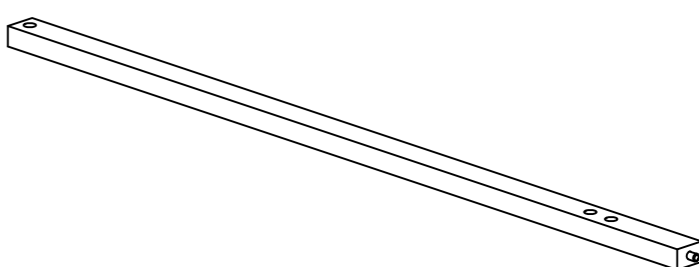
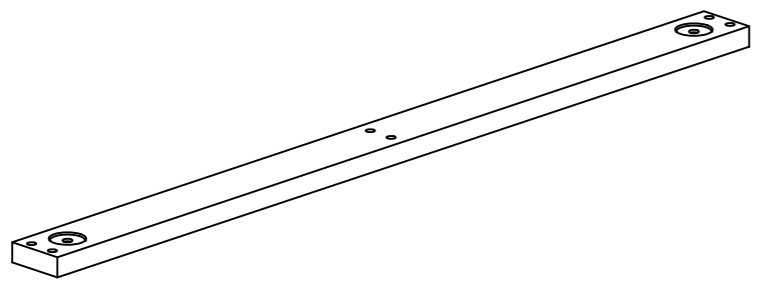

Part List

<p>A</p>  <p>Before Panel HB - 1pc</p>	<p>B</p>  <p>Upper Panel HB - 1pc</p>	<p>C</p>  <p>Lower Panel HB - 1pc</p>
<p>D</p>  <p>After Panel HB - 1pc</p>	<p>E</p>  <p>Panel FB - 1pc</p>	<p>F</p>  <p>Side Rail (1/2) - 2pcs</p>
<p>G</p>  <p>Side Rail (2/2) - 2pcs</p>	<p>H</p>  <p>Slats - 10pcs</p>	<p>I</p>  <p>Slat support - 2pcs</p>
<p>J</p>  <p>Leg support - 3pcs</p>	<p>K</p>  <p>Leg - 6pcs</p>	

Hardware List

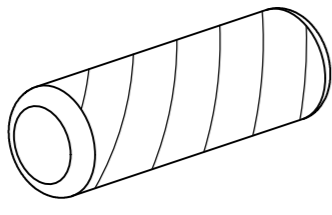
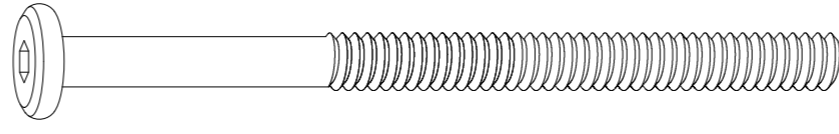
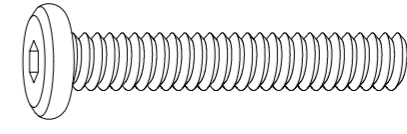
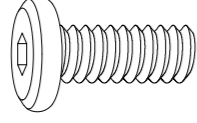
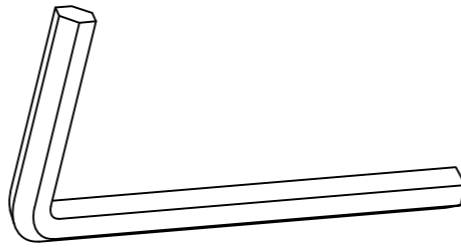
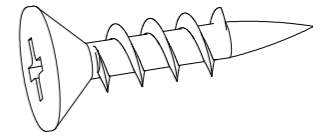
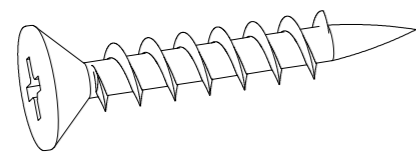
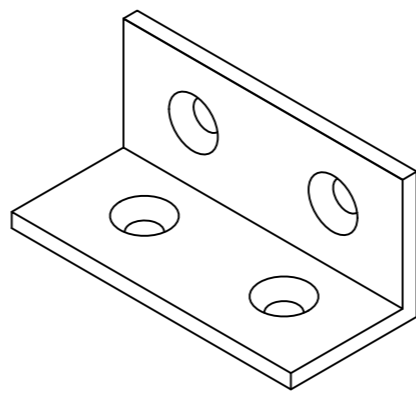
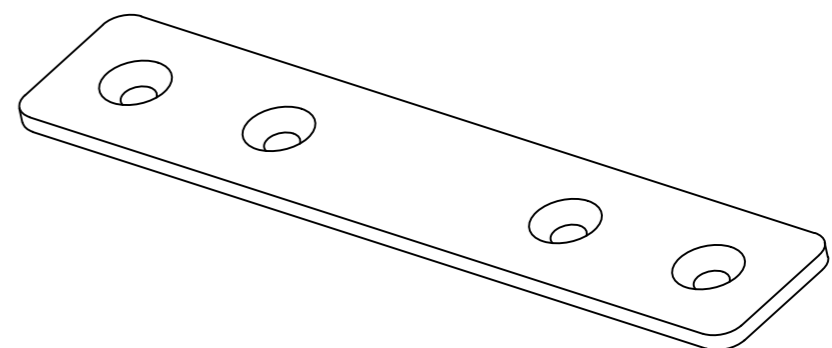
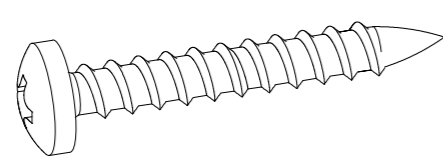
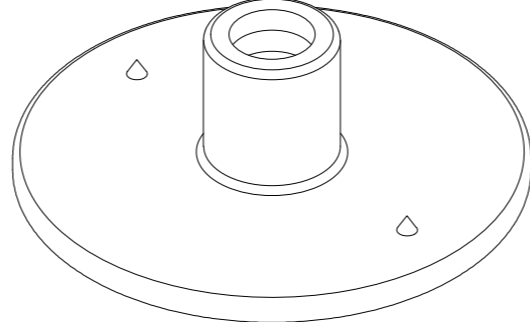
<p>1</p> <p>Spare hardware 2pcs</p>  <p>Ø8*25mm</p> <p>Wood-dowel (18pcs)</p>	<p>2</p> <p>Spare hardware 1pc</p>  <p>(Ø12)1/4" *90mm</p> <p>Hex-Head bolts (9pcs)</p>	<p>3</p> <p>Spare hardware 2pcs</p>  <p>(Ø12)1/4" *38mm</p> <p>Hex-Head bolts (20pcs)</p>
<p>4</p> <p>Spare hardware 1pc</p>  <p>(Ø12)1/4" *15mm</p> <p>Hex-Head bolts (9pcs)</p>	<p>5</p>  <p>(1/4") 4*60mm</p> <p>Allen key (1pc)</p>	<p>6</p> <p>Spare hardware 1pc</p>  <p>Ø4*12mm</p> <p>Wood screws (9pcs)</p>
<p>7</p> <p>Spare hardware 1pc</p>  <p>Ø4*16mm</p> <p>Wood screws (9pcs)</p>	<p>8</p>  <p>35*18*18*2mm</p> <p>Metal-bracket (2pcs)</p>	<p>9</p>  <p>100*20*2mm</p> <p>Metal-bracket (2pcs)</p>
<p>10</p>  <p>Ø4*32mm</p> <p>Wood screws (4pcs)</p>	<p>11</p>  <p>M8*Ø36*17mm</p> <p>T-Nut (6pcs)</p>	

ASSEMBLY TOOLS REQUIRED (NOT INCLUDED)

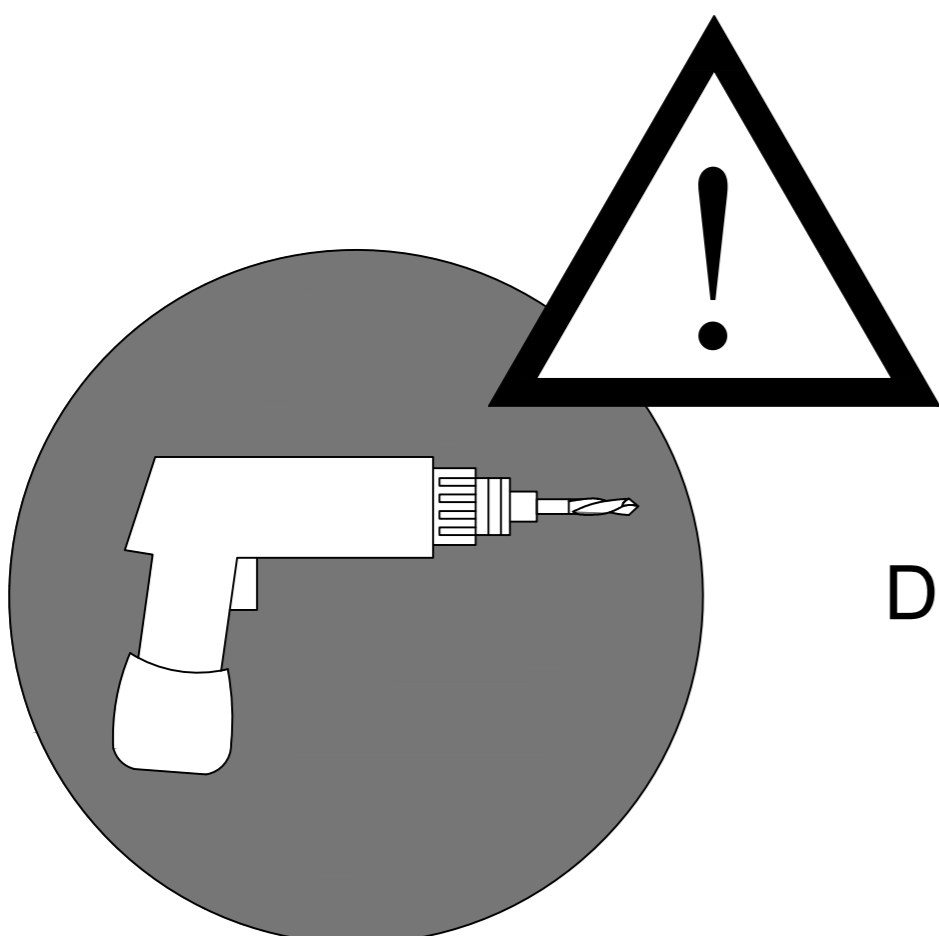
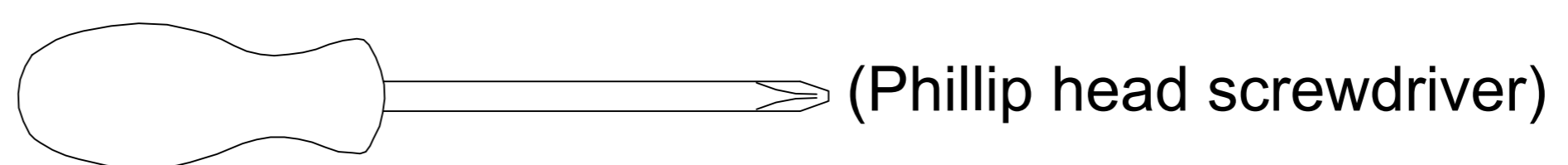

DO NOT USE POWER TOOLS TO ASSEMBLE THIS PRODUCT !

Remark: We recommend you assemble your bed in the flat ground.

STEP 1:

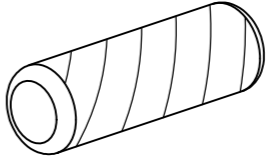
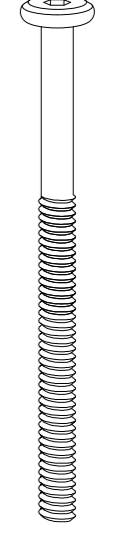
1	2
	
4PCS	8PCS

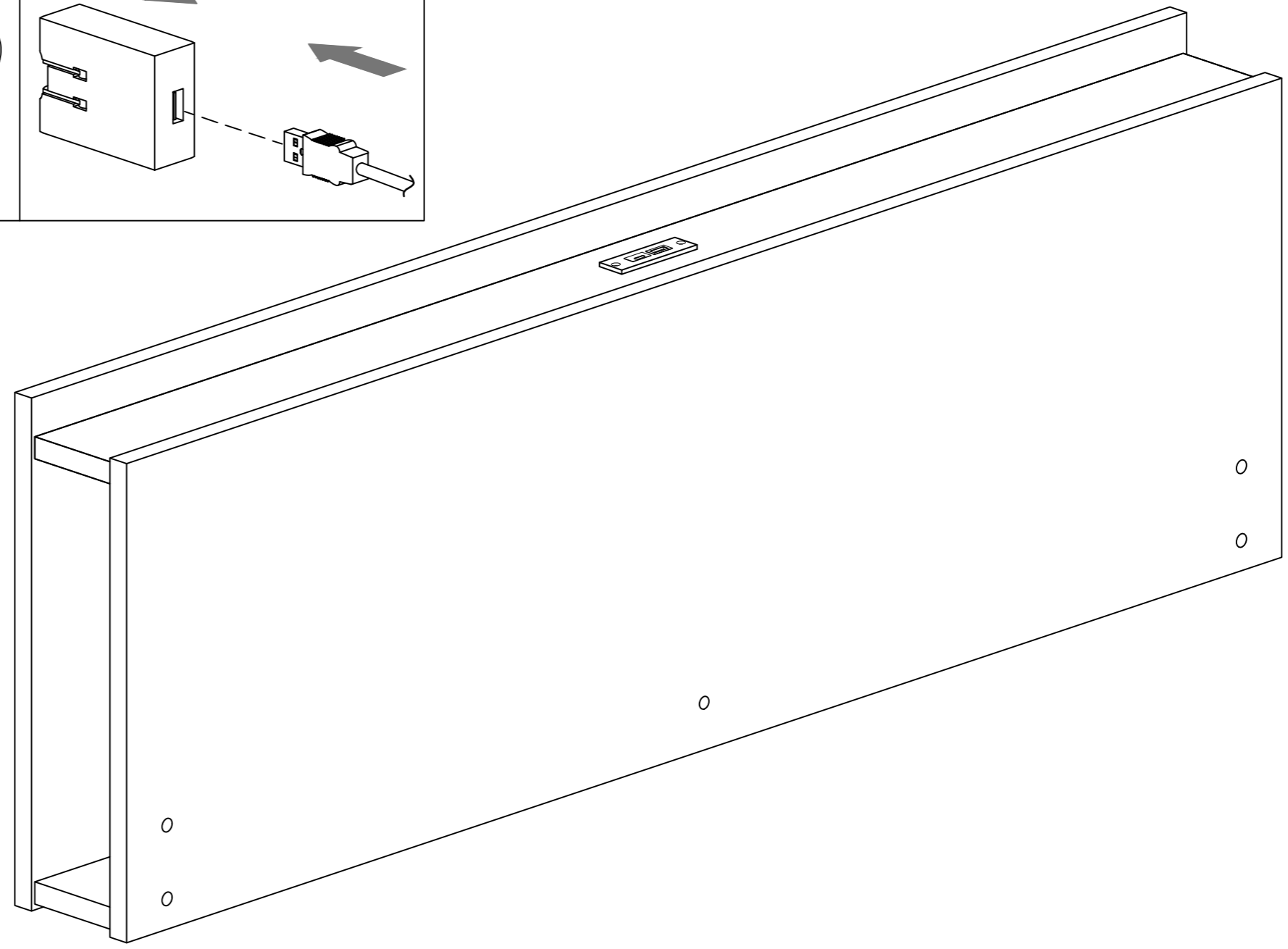
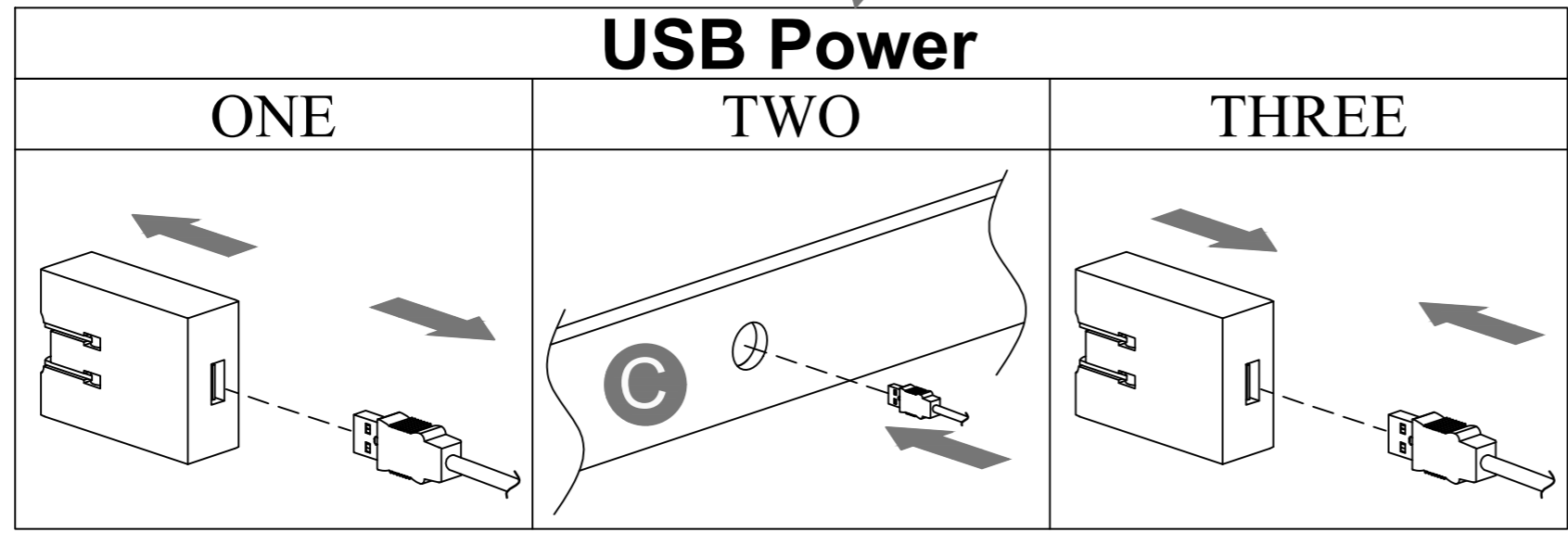
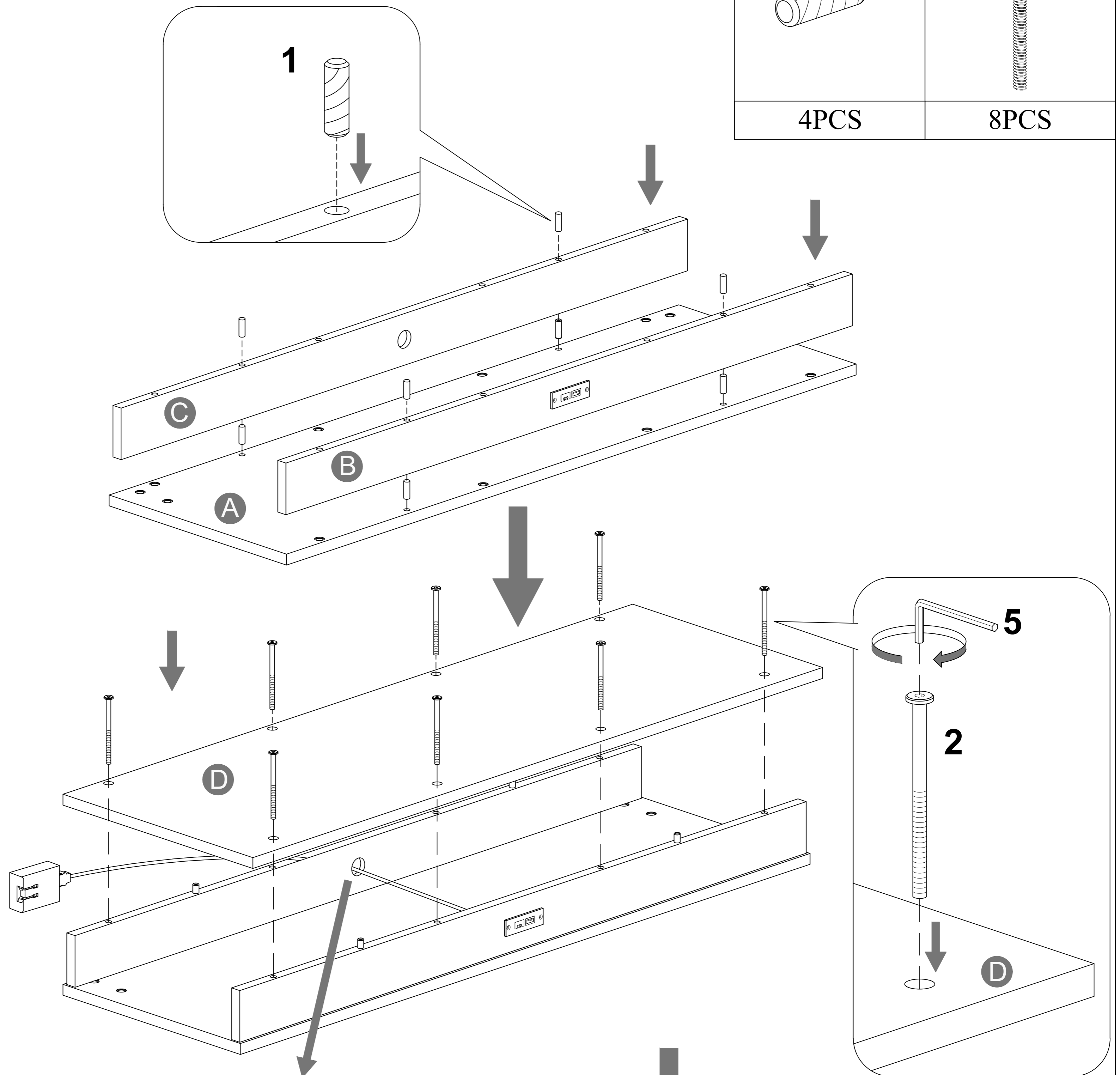

STEP 2:

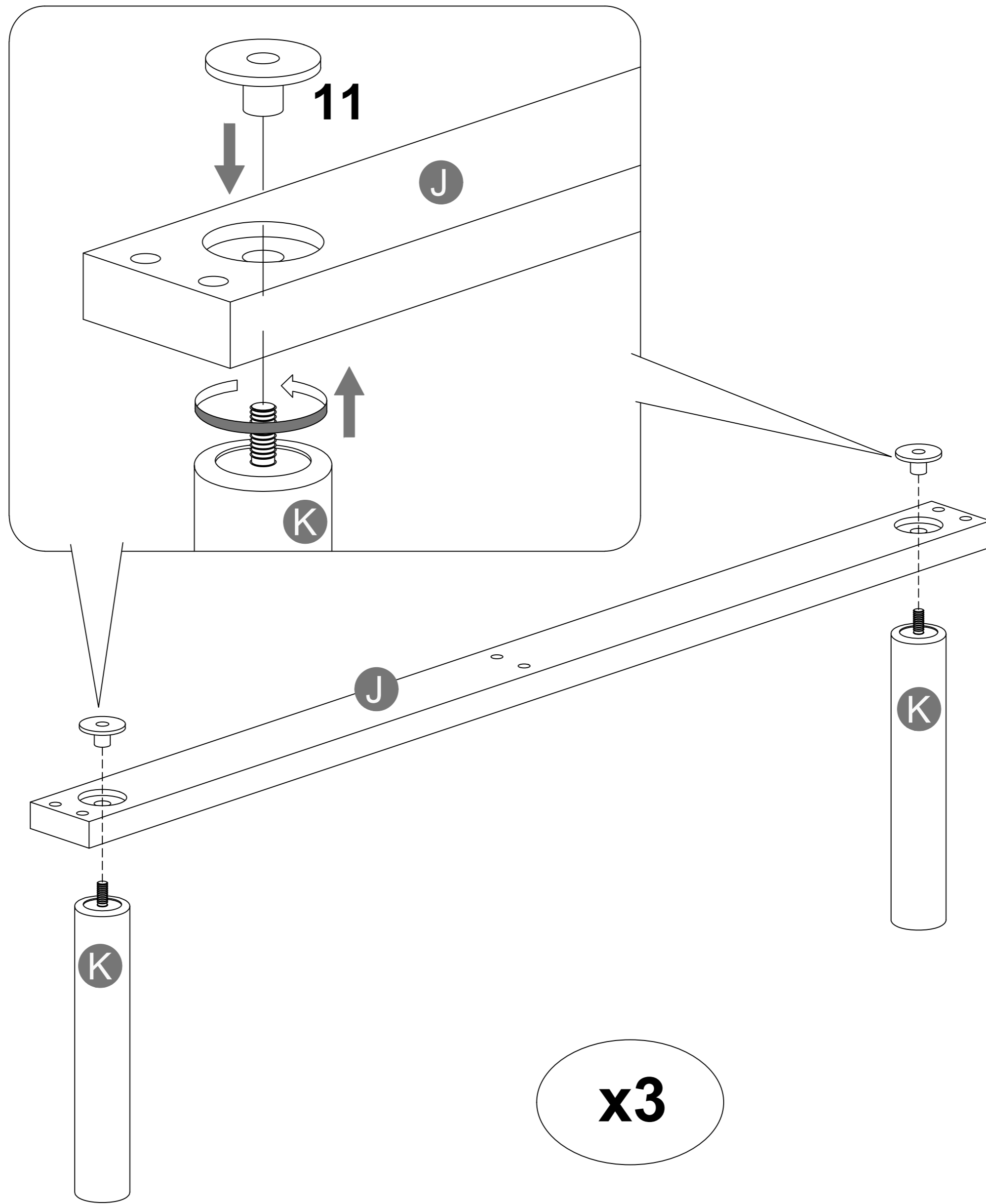

11

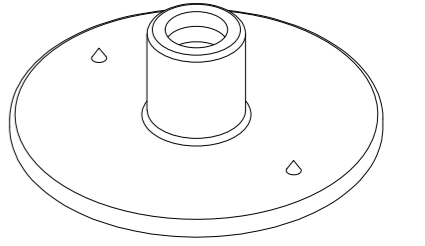

6PCS

x3

STEP 3:

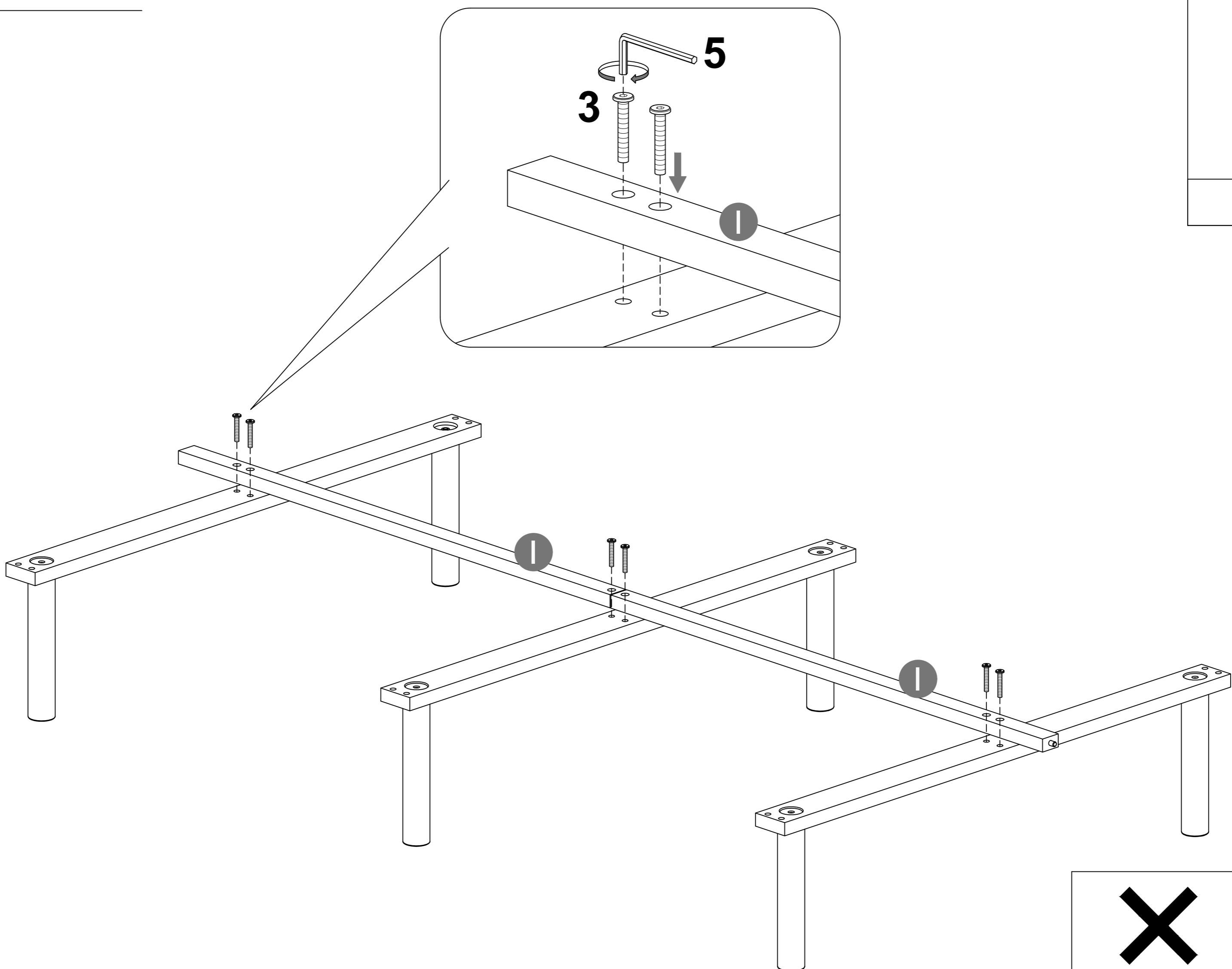

3

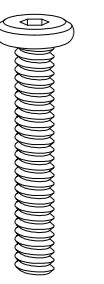

6PCS

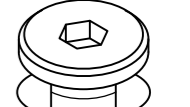
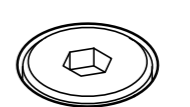
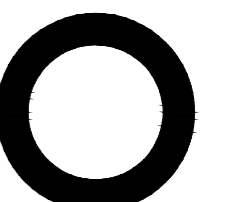
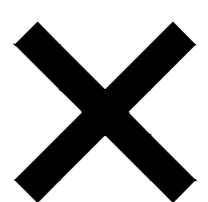

STEP 4:

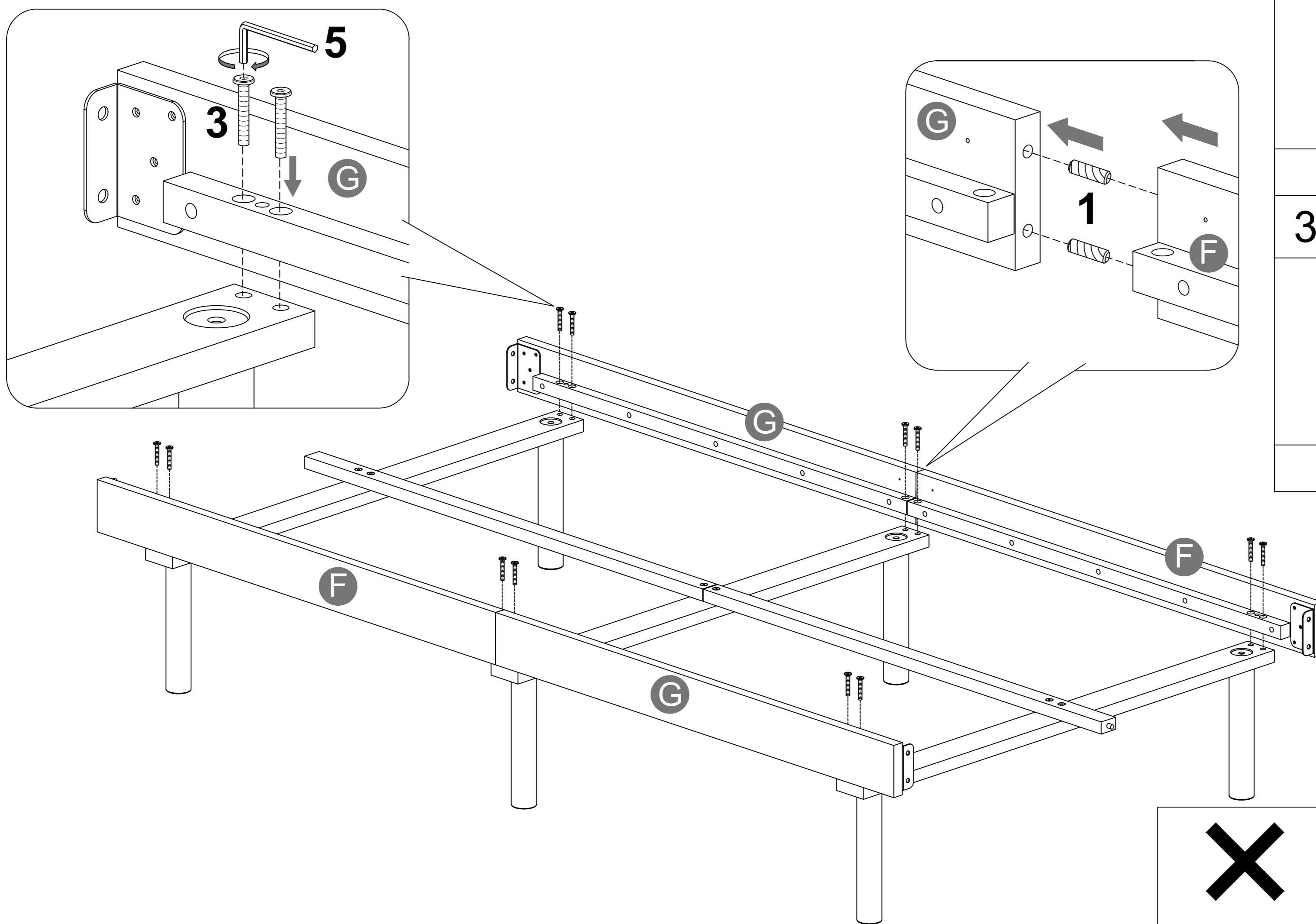

1

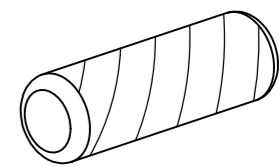

4PCS

3



12PCS

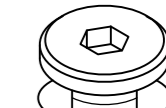
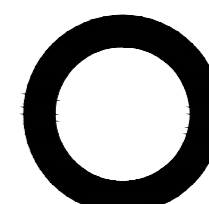
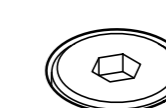
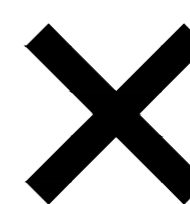

STEP 5:

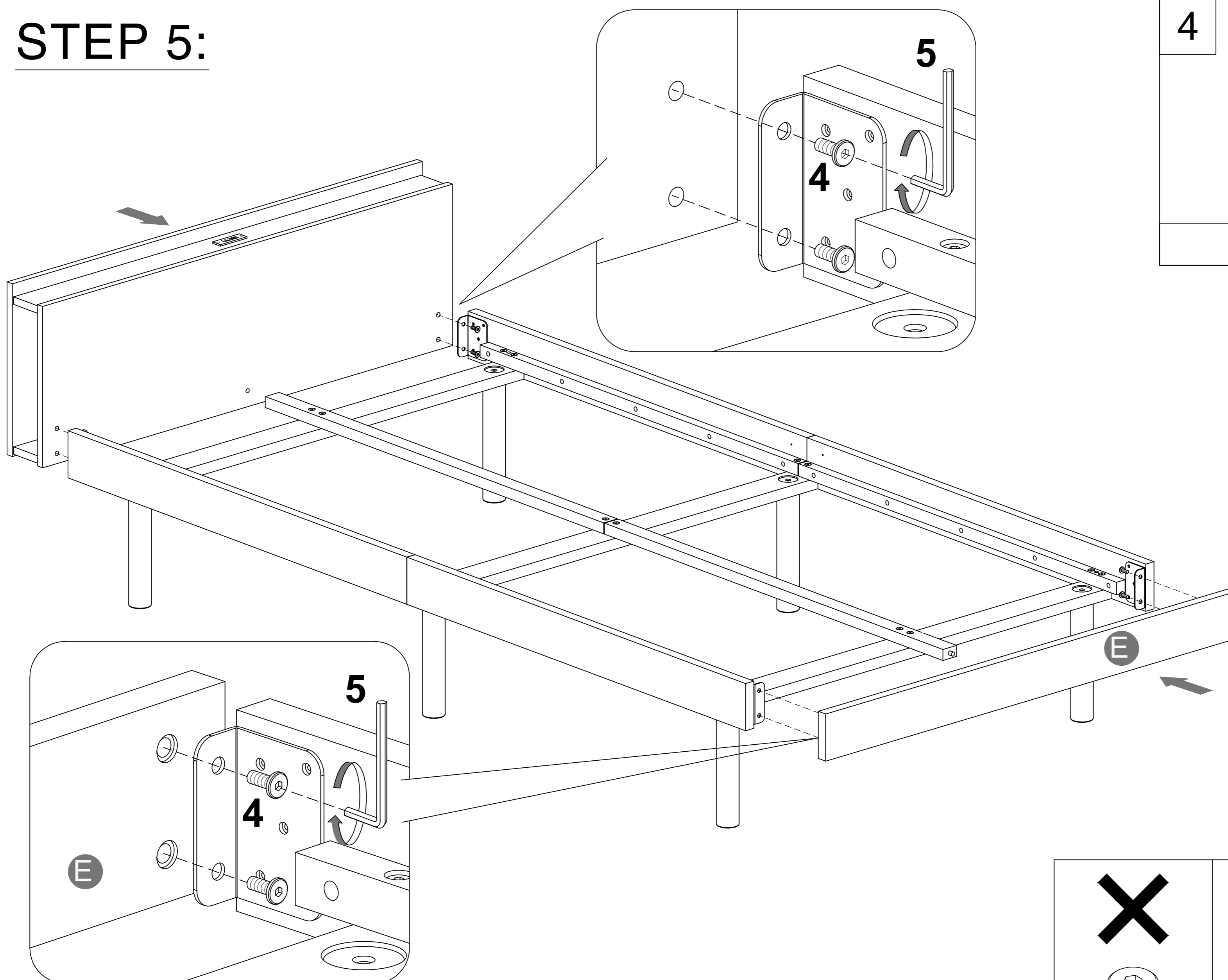

4

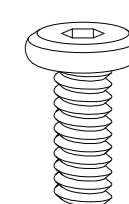

8PCS

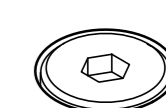
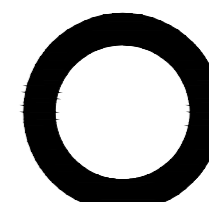
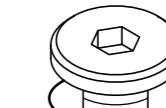

STEP 6:

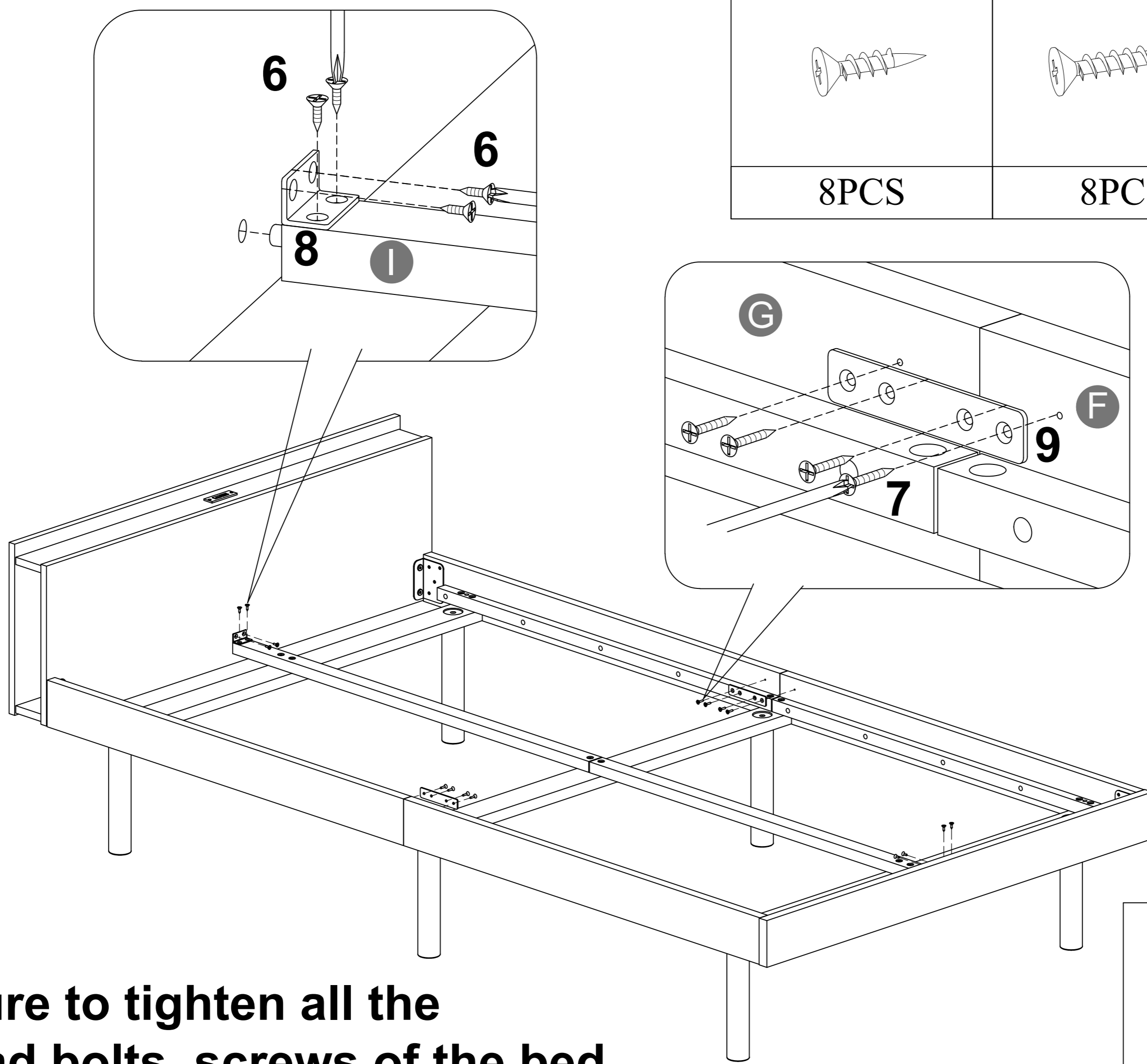

6	7	8
8PCS	8PCS	2PCS
		9
		2PCS

Make sure to tighten all the Hex-Head bolts, screws of the bed

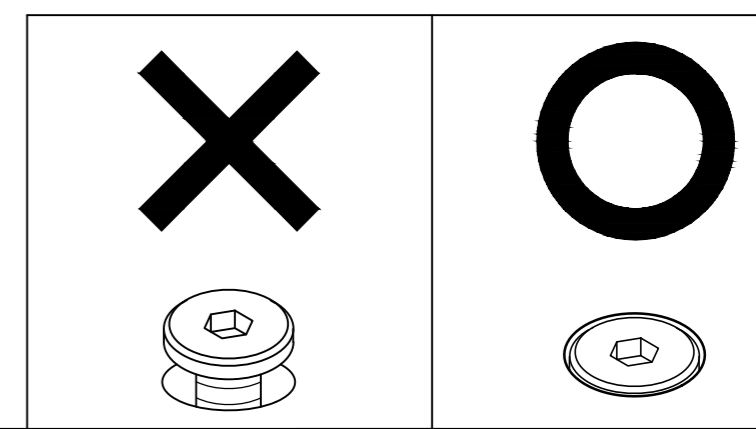

STEP 7:

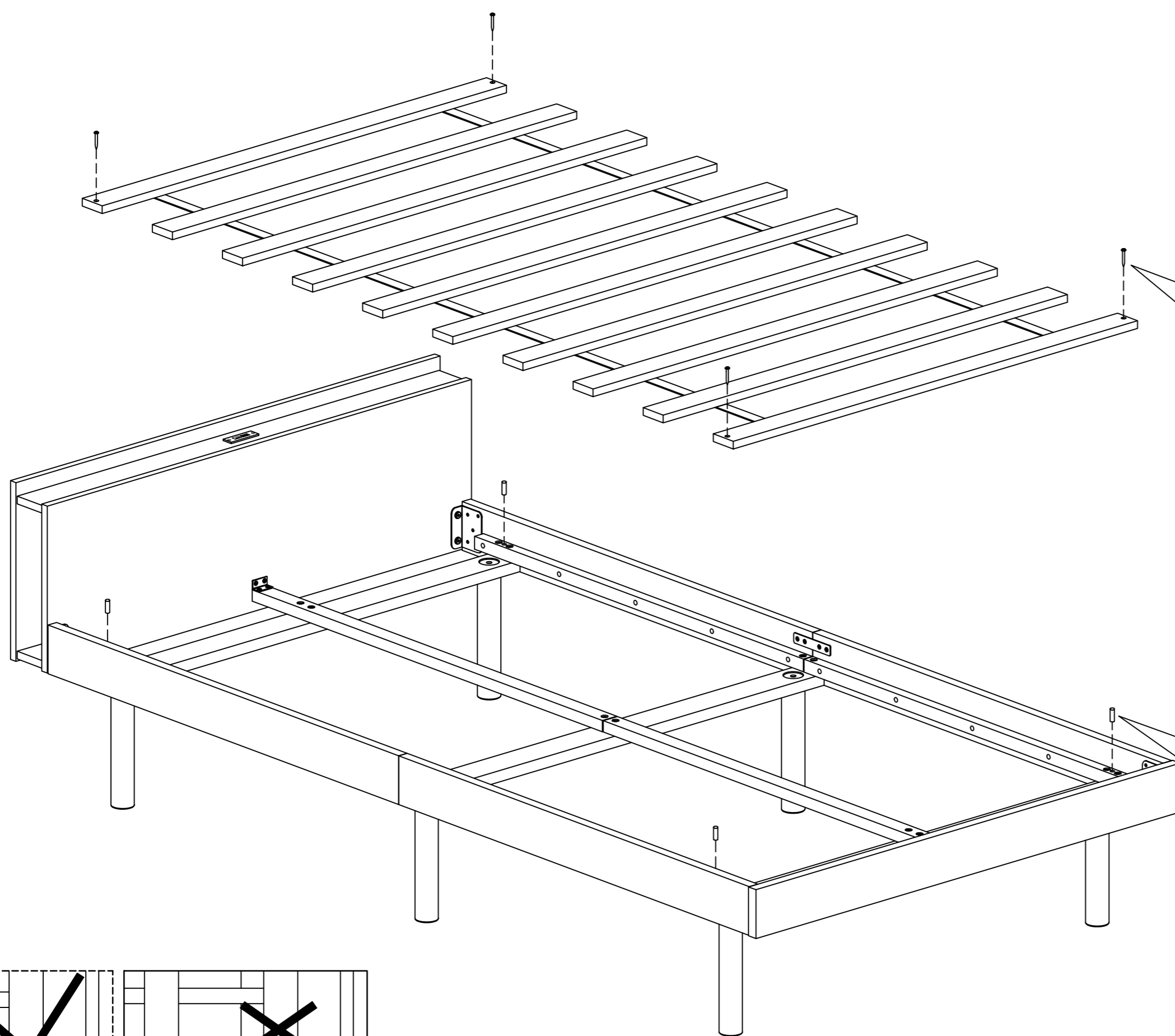

1	10
4PCS	4PCS

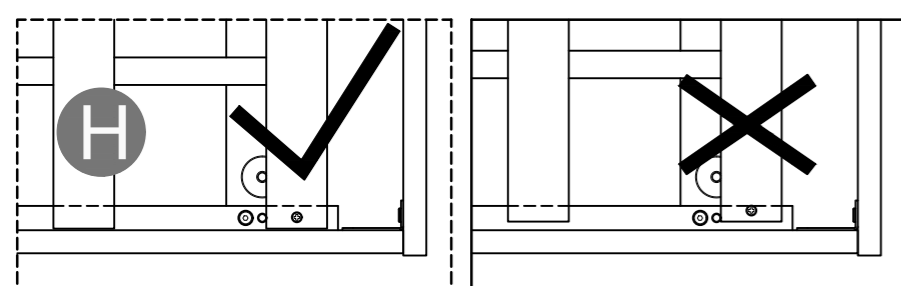
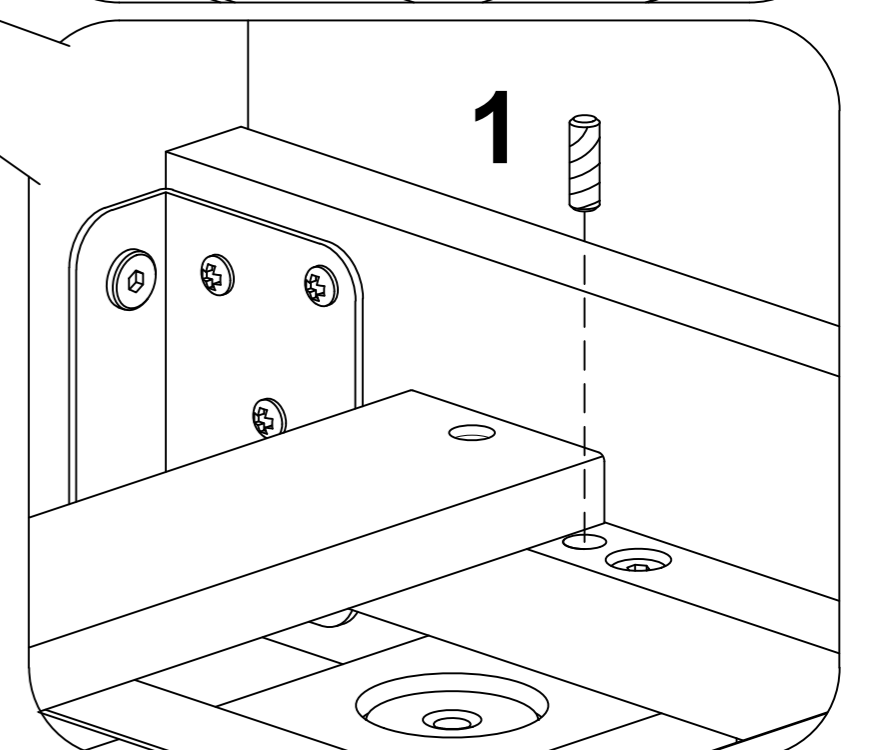
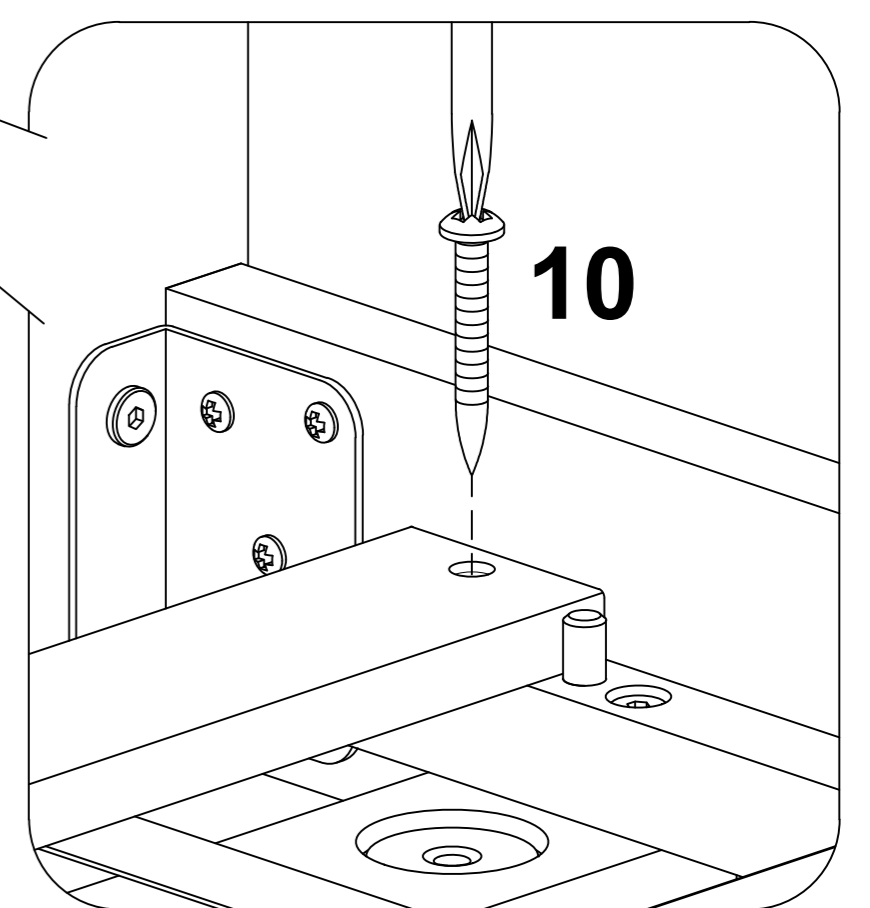

Note: Do not lock the screws of the bed slats to the outermost edge of the bed slats, you need to leave a certain space at the edges, otherwise it will cause the board to break. Do not lock the bed slats on the edge of the wood, please hold firmly before screwing, hold it in place with one hand, then lock the screw.