

WICHTIG - FÜR SPÄTERE VERWENDUNG  
AUFBEWAHREN - SORGFÄLTIG LESEN

AVIS - Ces instructions doivent être sauvegardées  
Pour utilisation future - Les instructions doivent  
être suivies

IMPORTANTE, conservar estas instrucciones  
para futuro uso. Siga estas instrucciones atentamente

VIGTIGT - Samvejledningen skal opbevares  
i arkiv til senere brug - Skal gennemlæses nøje

NOTICE - These instructions must be saved  
for future use - Instructions must be followed

TEILCHECKLISTE  
 LISTE DE CONTROLE  
 LISTADO DE CONTROL  
 TJEKLISTE  
 CHECK LIST

| Réf./No. | Qty./Stck./Quantité | Size / Maß / Dimension (mm) | Qty./Stck./Quantité | ✓ |
|----------|---------------------|-----------------------------|---------------------|---|
| 1        | 1                   | 1590x680x75                 |                     |   |
| 2        | 1                   | 1490x180x50                 |                     |   |
| 3        | 1                   | 1490x180x50                 |                     |   |
| 4        | 2                   | 2100x180x55                 |                     |   |
| 5        | 3                   | 400x80x30                   |                     |   |
| 6        | 4                   | 267x70x70                   |                     |   |
| 7        | 1                   | 2050x70x30                  |                     |   |
| 8        | 3                   | 220x40x40                   |                     |   |
| 9        | 1                   | 1535x70x15                  |                     |   |
| 10       | 1                   | 1865x1532x15                |                     |   |

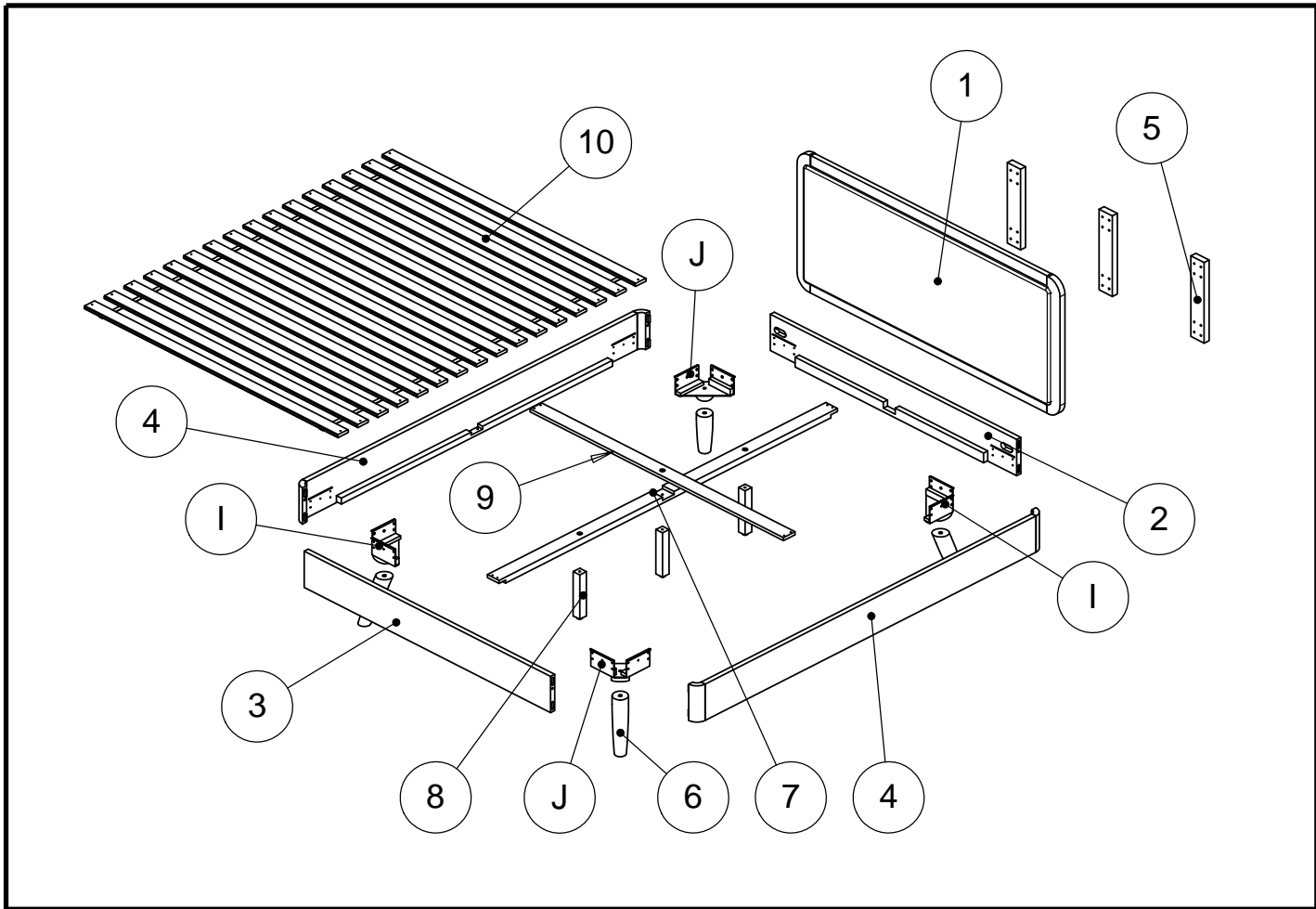

Sollten Sie eventuelle Ersatzteile oder Reklamationsteile fordern, dann bitten wir Sie, diese Seite mitzubringen.

En cas de service apres - vente, veuillez nous retourner ce coupon.

En caso de necesitar piezas de repuesto, por favor adjunte esta página.

Skulle de få brug for reklamationsdele, beder vi dem medsende denne side.

If you should be in the need of spareparts, please enclose this page.

Name/Nom/Nombre/Navn: \_\_\_\_\_

Adresse/Dirección/Address: \_\_\_\_\_

PLZ/Code postale/CP/Post.nr: \_\_\_\_\_

Telefon/Telephone/Telefono/Phone: \_\_\_\_\_

Oberfläche/Finition/Tratamiento/ Handling/Treatment: \_\_\_\_\_

No./Réfrence: \_\_\_\_\_

Ursache/Motif/Motivo/Årsag/Reason: \_\_\_\_\_





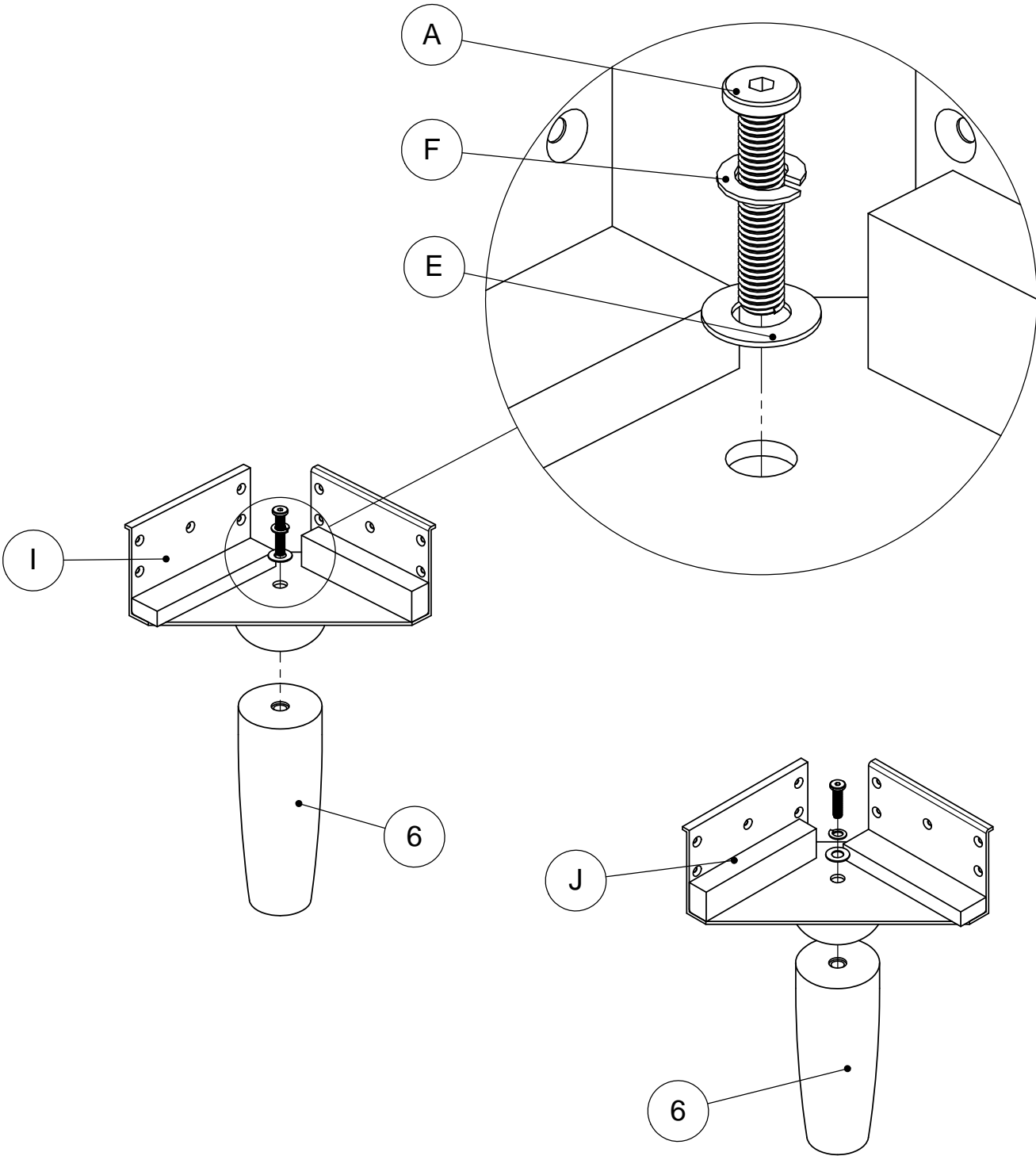
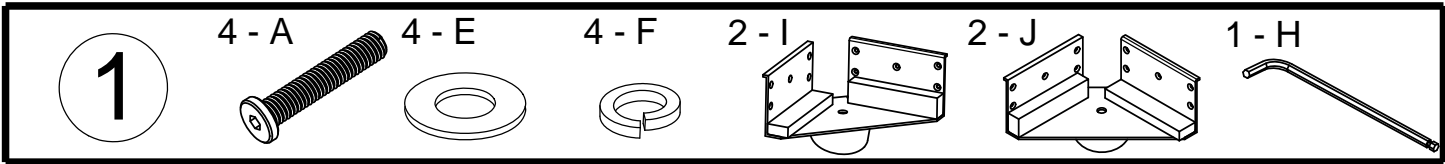

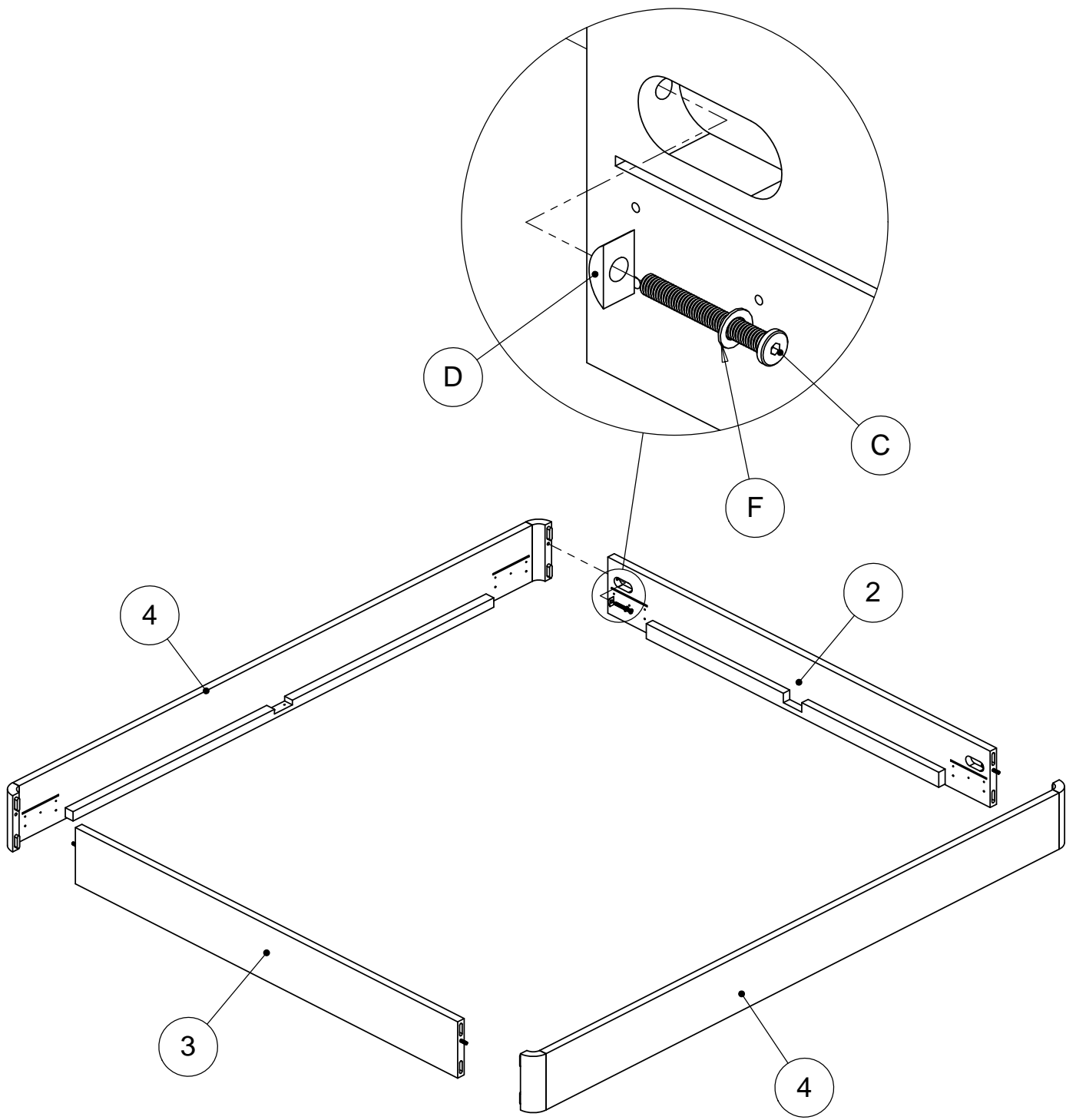
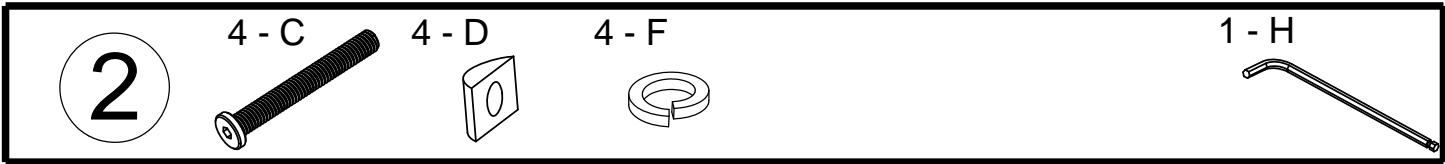



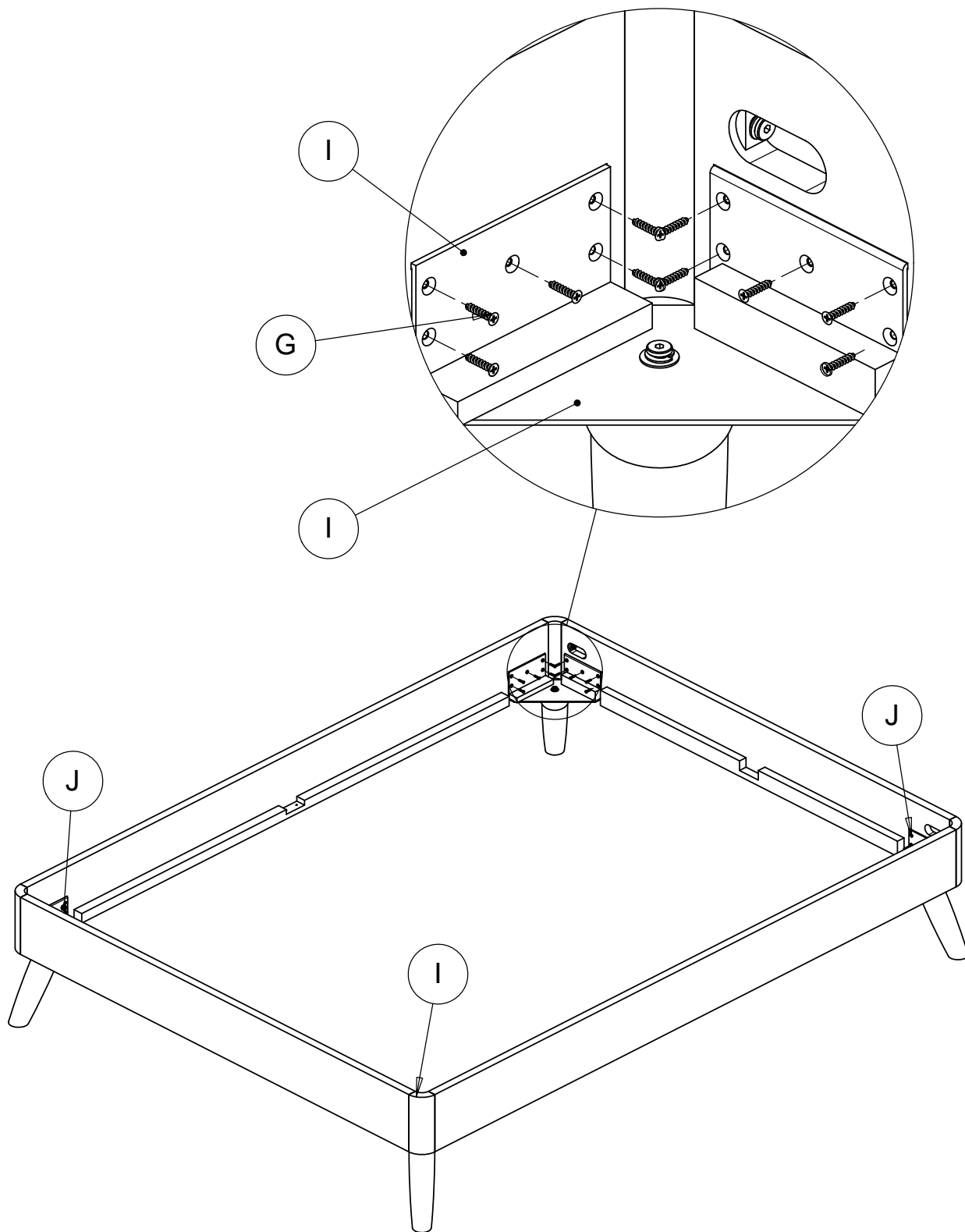
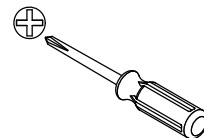
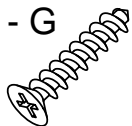

3

40 - G

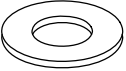

|   |   |   |   |  |
|---|---|---|---|--|
| 4 | 24 - B<br> | 24 - E<br> | 24 - F<br> | 1 - H<br> |
|---|---|---|---|--|

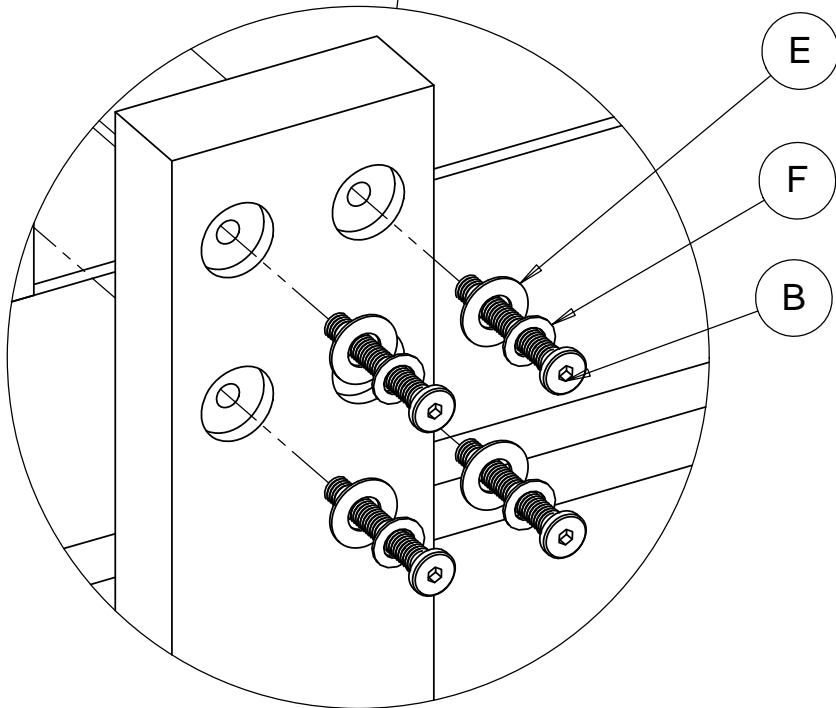
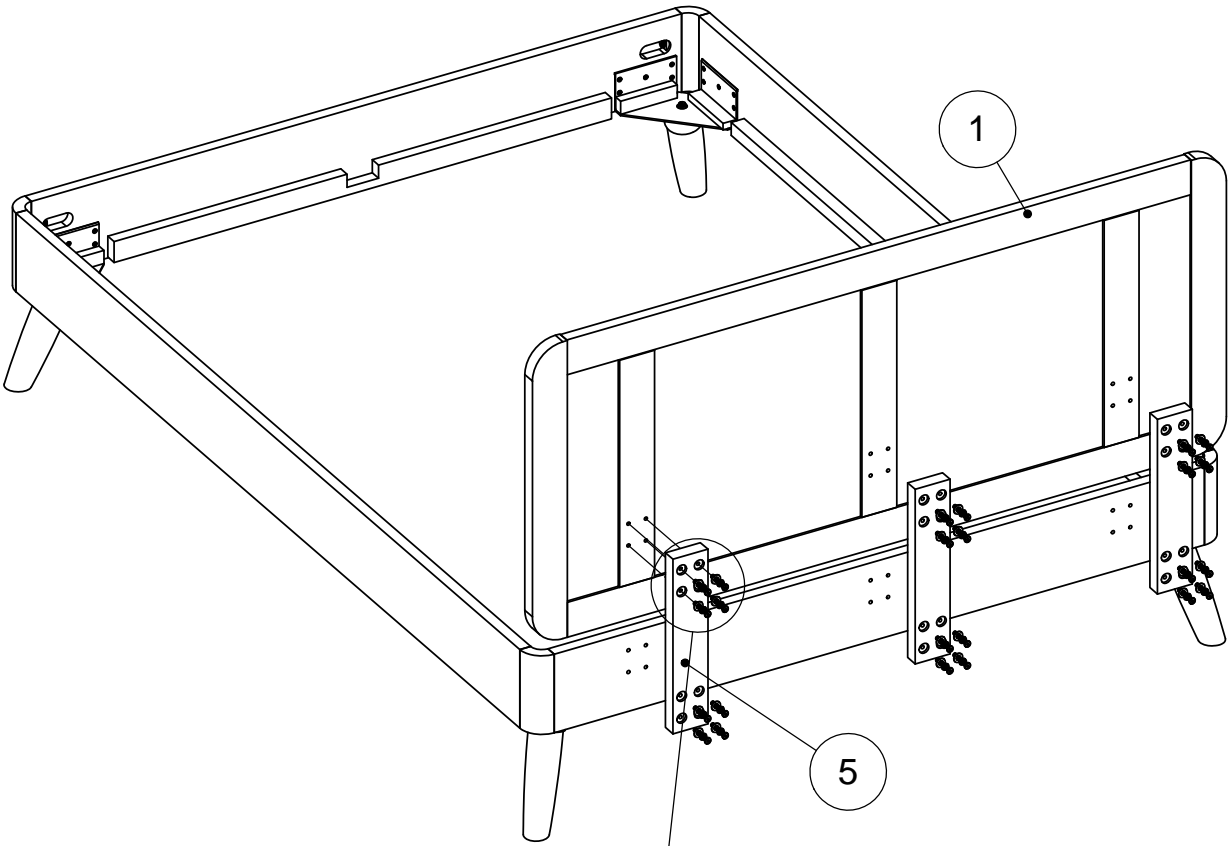

5

3 - B

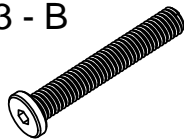

1 - H

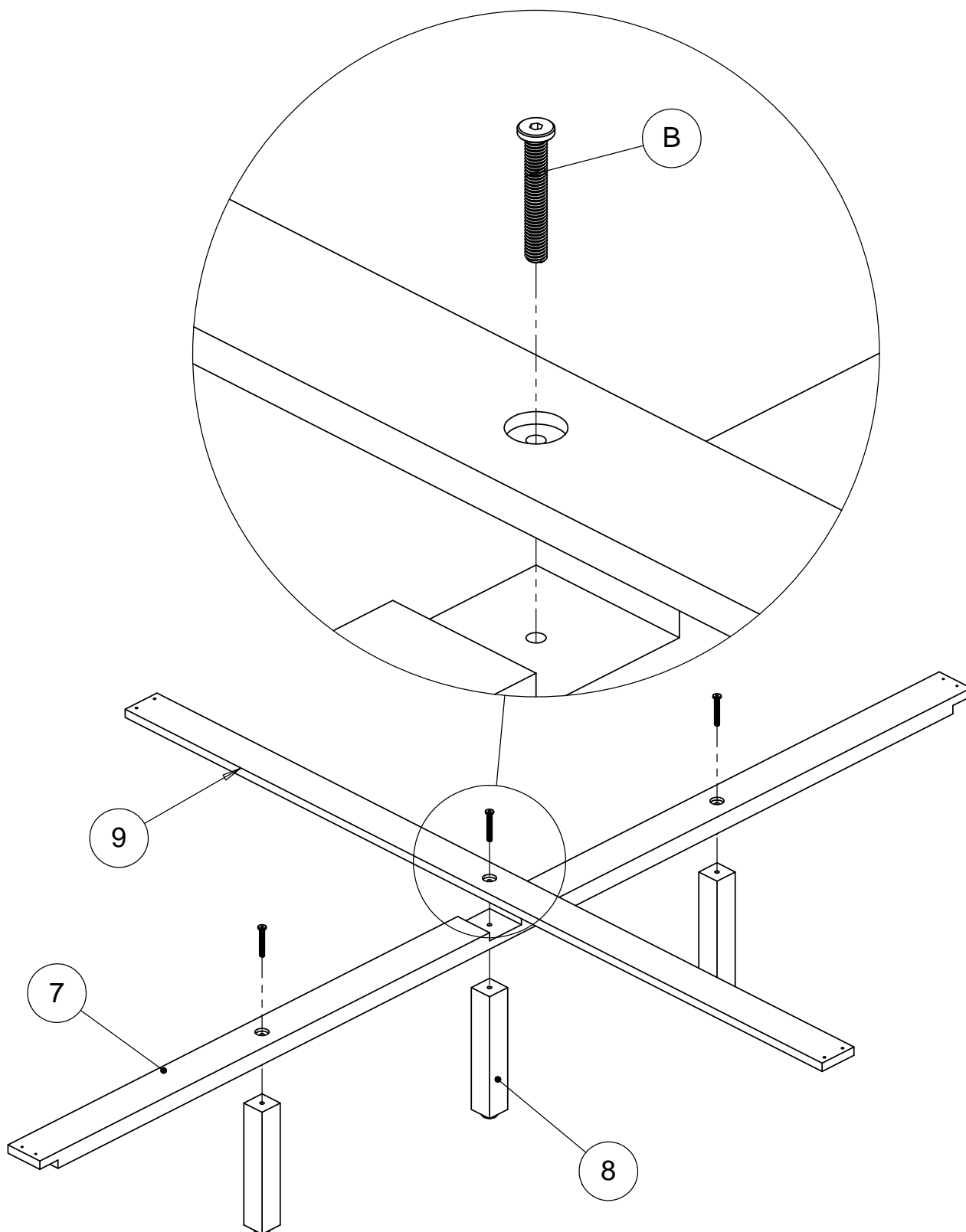

6

8 - K

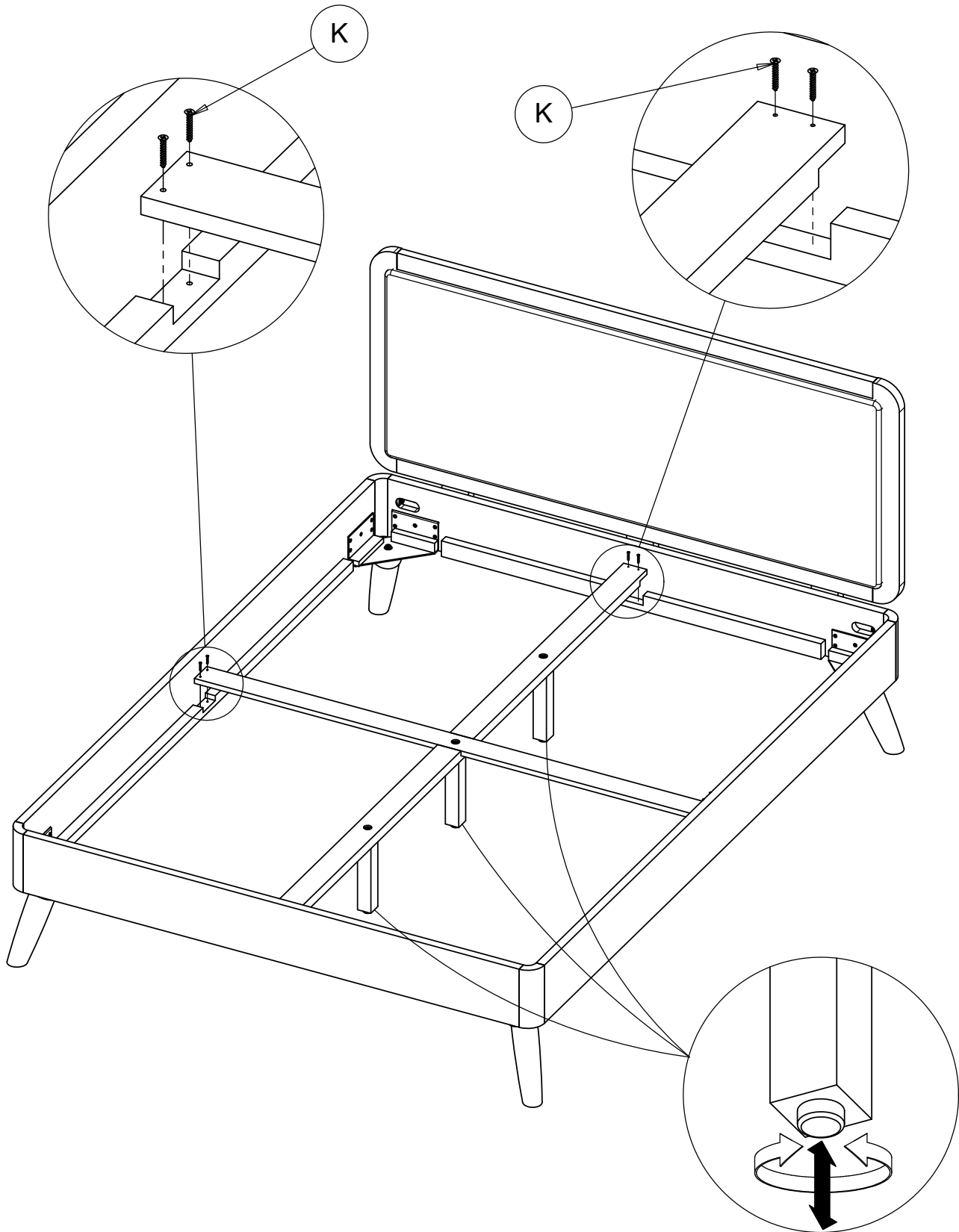
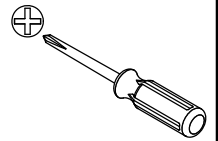
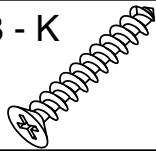

7

6 - G

