

ASSEMBLY INSTRUCTIONS

TWIN DAY BED

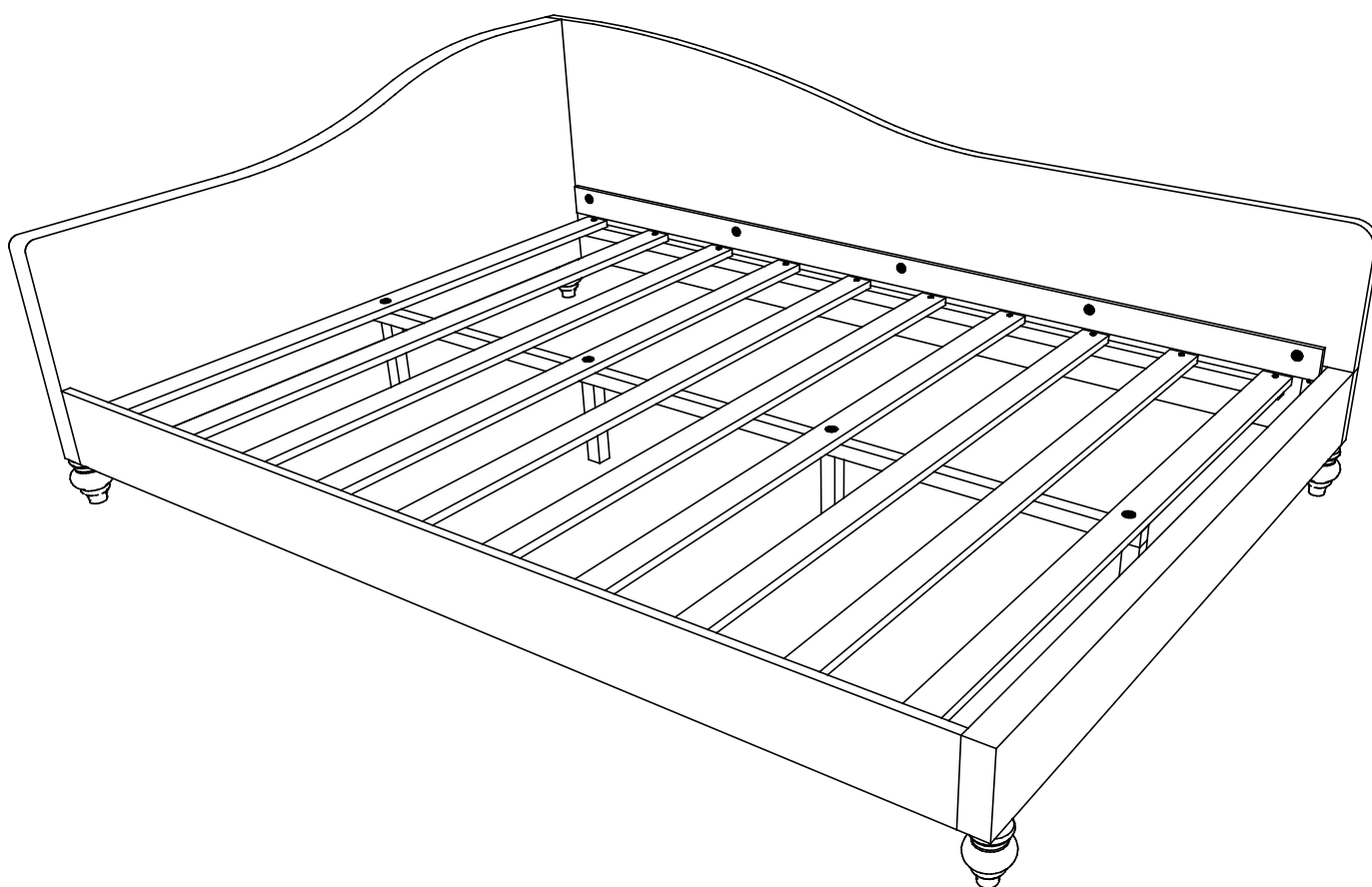

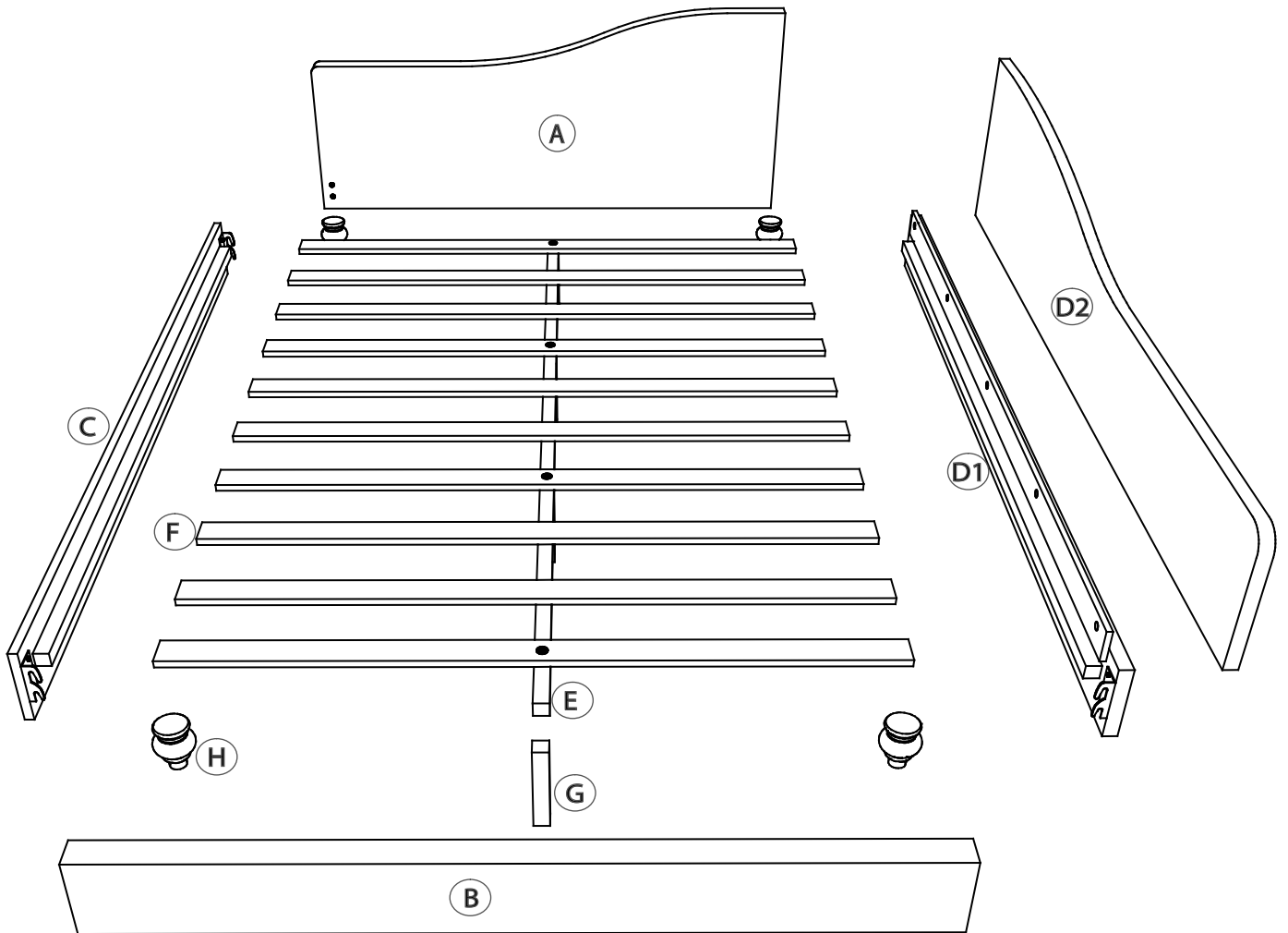

WF323809 & WF323810

Detail View





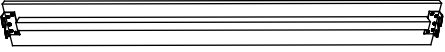
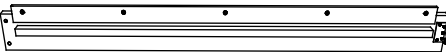

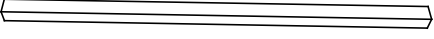
Part List

WF323809

C  LEFT SIDE RAIL - 1PC	D1  BOTTOM RIGHT SIDE RAIL - 1PC	D2  TOP RIGHT SIDE RAIL - 1PC
E  CENTER SUPPORT BAR - 1PC		

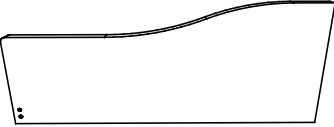
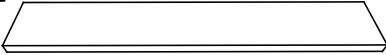



Part List

WF323810

A  HEADBOARD - 1PC	B  FOOTBOARD - 1PC	F  SLATS - 10PCS
G  CENTER SUPPORT LEGS - 4PCS	H  HEAD&FOOTBOARD LEGS - 4PCS	

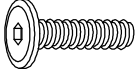
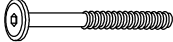
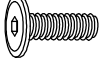
Hardware List

in WF323810

1  Allen key (1pc)	2  5/16"*45mm Hex-Head bolts (4pcs)	3  1/4"*60mm Hex-Head bolts (4pcs)
4  5/16"*30mm Hex-Head bolts (11pcs)	5  5/16" Flat Washer (15pcs)	6  1/4" Flat Washer (4pcs)
7  F4*35mm Screw (20pcs)		

ASSEMBLY TOOLS REQUIRED (NOT INCLUDED)

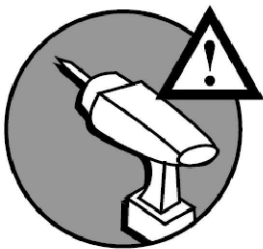
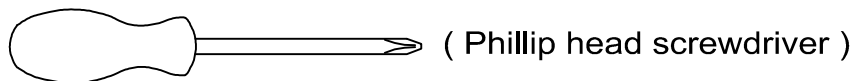

DO NOT USE POWER TOOLS TO ASSEMBLE THIS PRODUCT !

STEP 1:

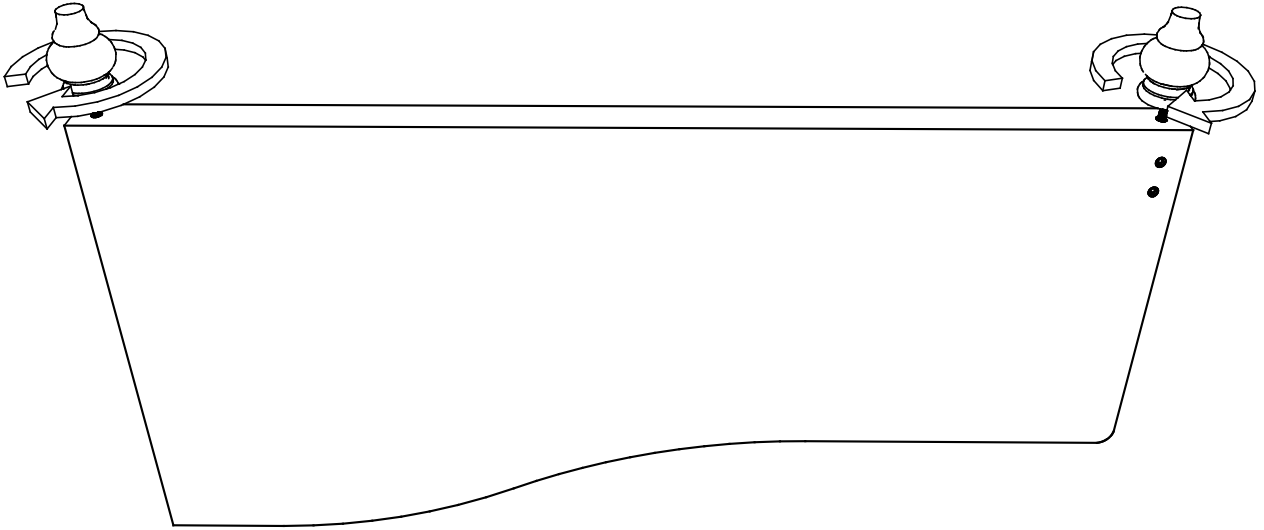

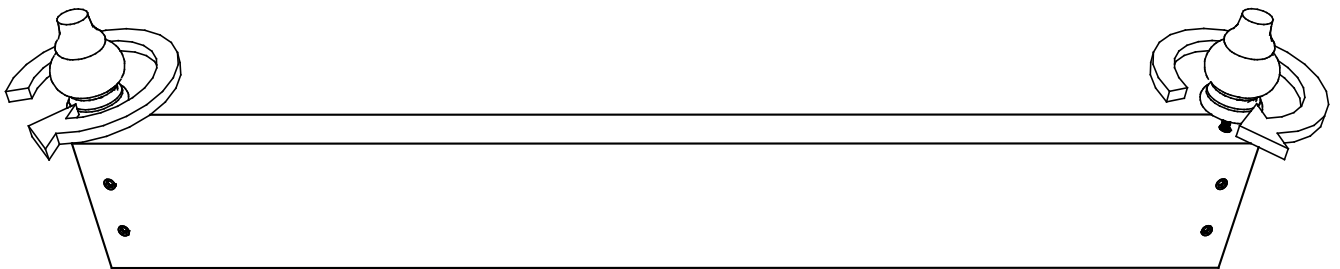

- Screw in Head & FootBoard Legs (H) to HeadBoard (A).

STEP 2:



- Screw in Head & FootBoard Legs (H) to FootBoard (B).

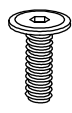

STEP 3:

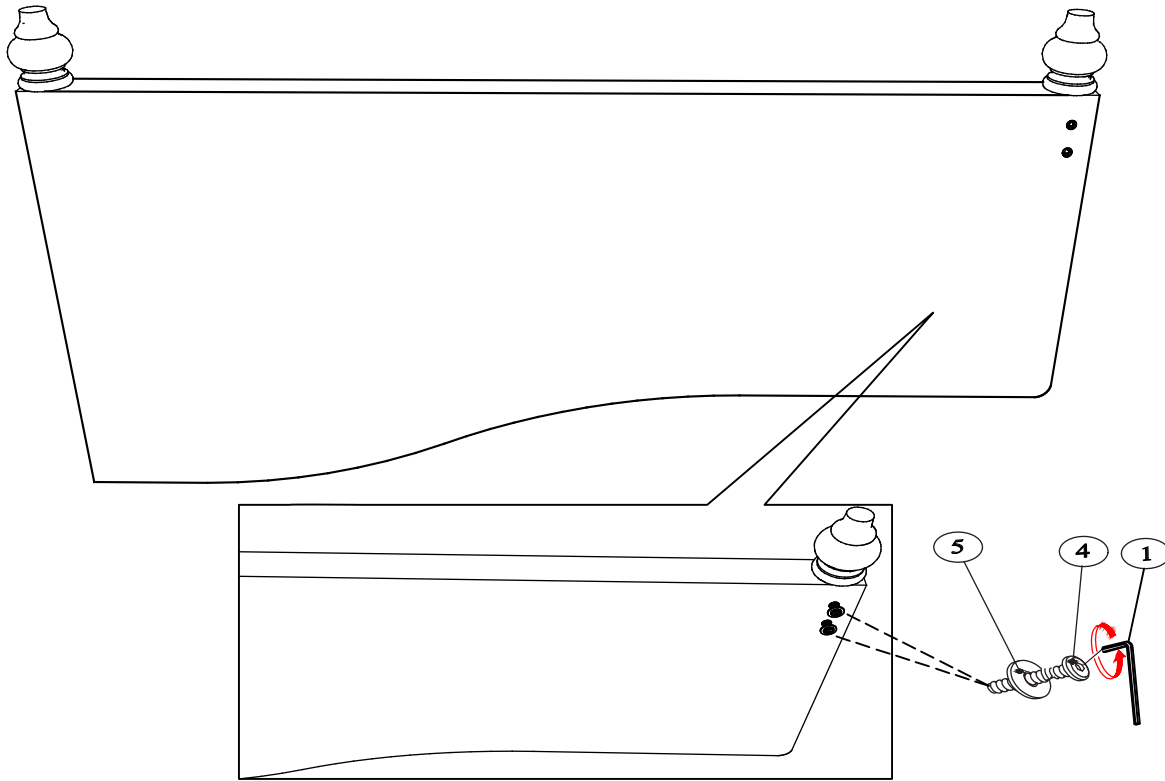
4		5	
2PCS		2PCS	



- Use Allen Key (1) to loosely (do not tighten) drive Bolt (4) with Flat Washer (5) onto the Headboard (A).

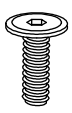

STEP 4:

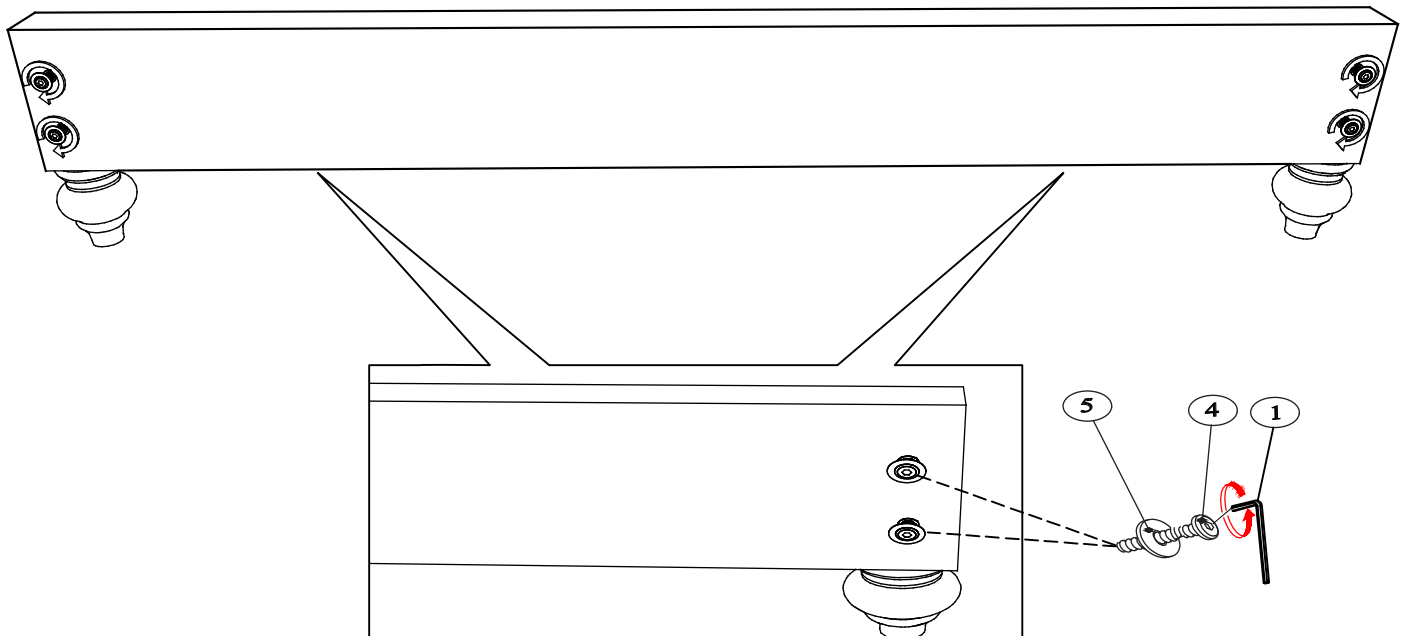
4		5	
4PCS		4PCS	

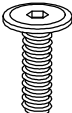

- Use Allen Key (1) to loosely (do not tighten) drive Bolt (4) with Flat Washer (5) onto the Footboard (B).

STEP 5:

4		5	
5PCS		5PCS	

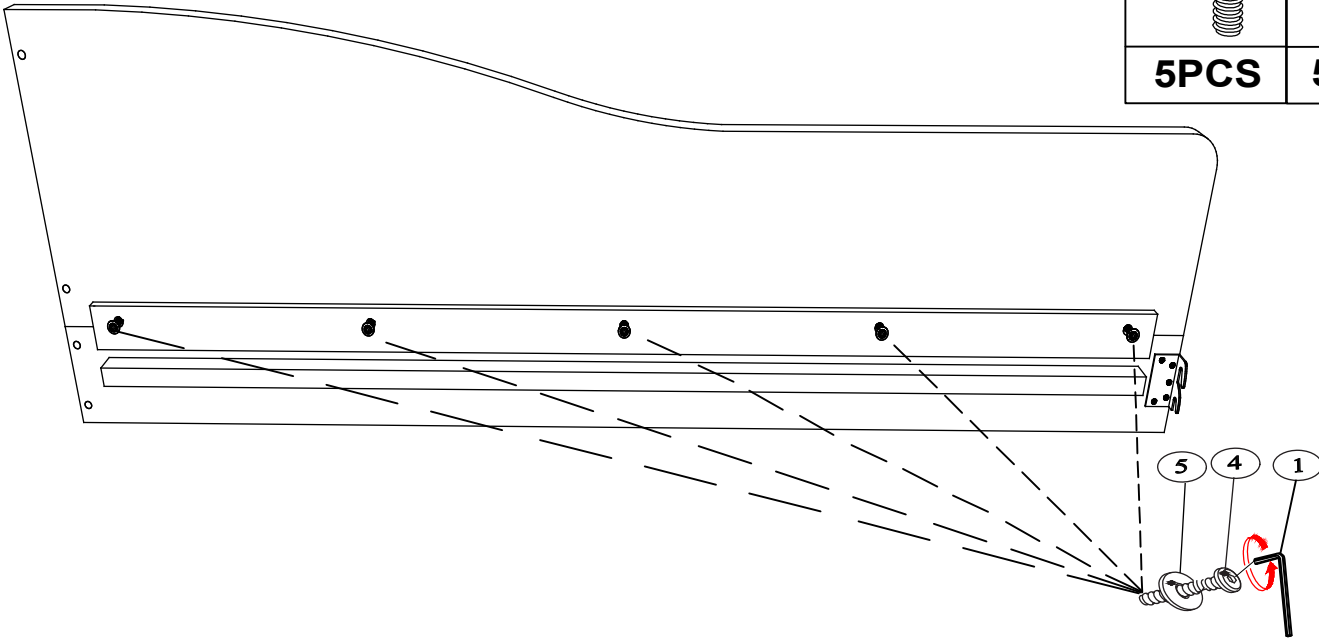

- Connect TOP RIGHT SIDERAIL to BOTTOM RIGHT SIDERAIL by use Bolt (4) with Flat Washer (5). Then tighten the bolts fully.

STEP 6:

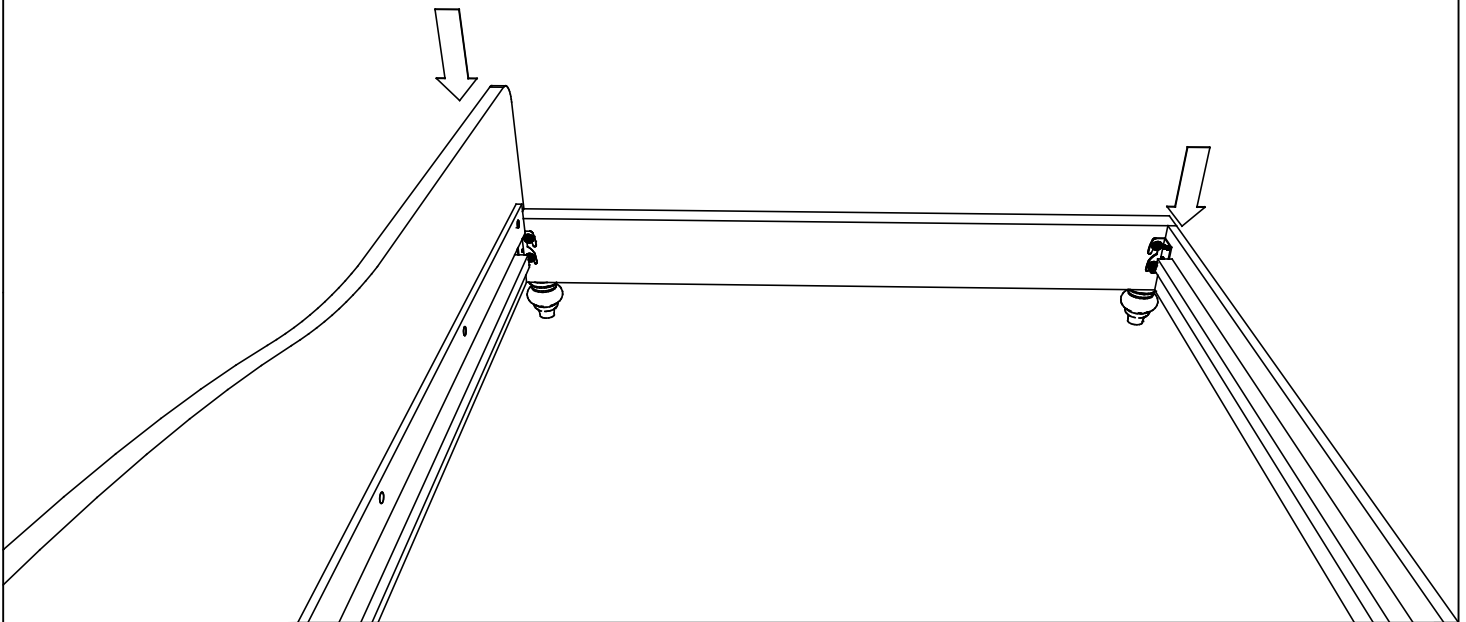

- Place the hook of Left & Right SideRail (C & D1,D2) to Bolt (4) on the FootBoard (B). Then tighten the Bolt (4) fully.

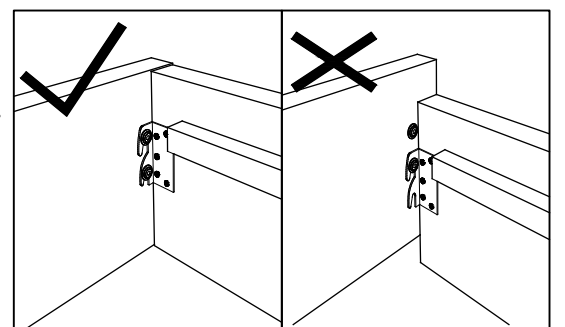

STEP 7:

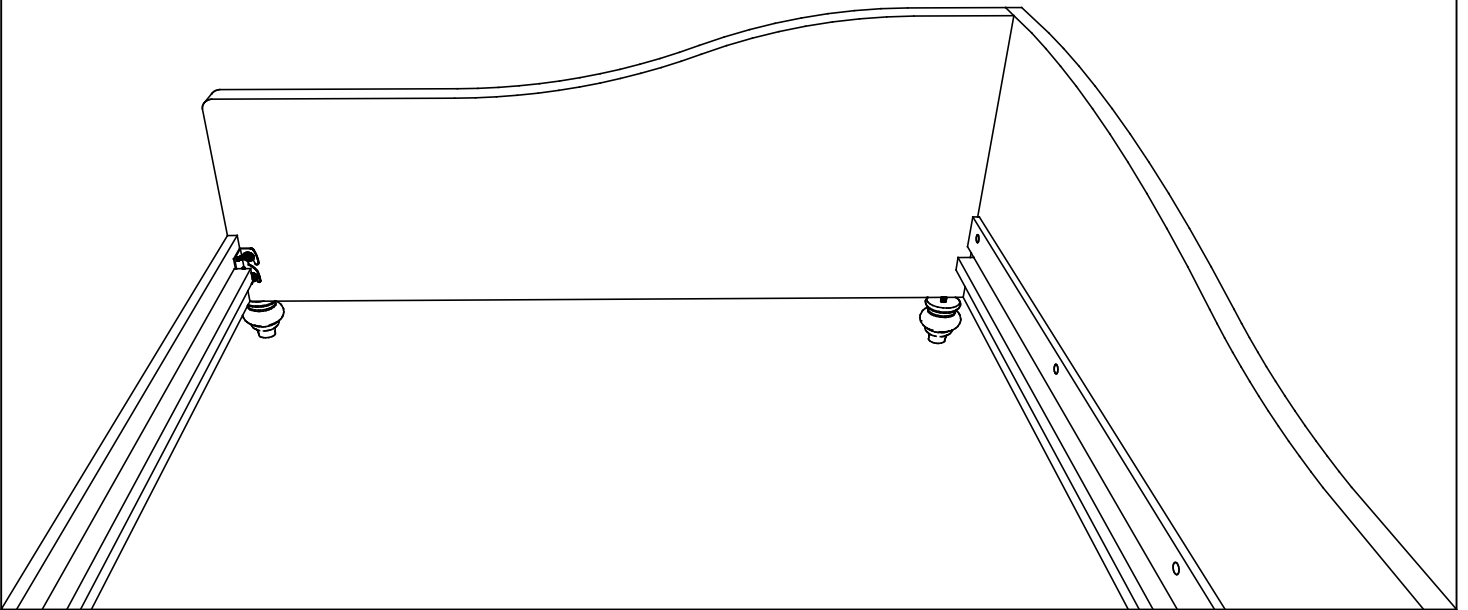

- Place the hook of Left SideRail (C) to Bolt (4) on the HeadBoard (A). Then tighten the Bolt (4) fully.

STEP 8:

2		5	
4PCS		4PCS	

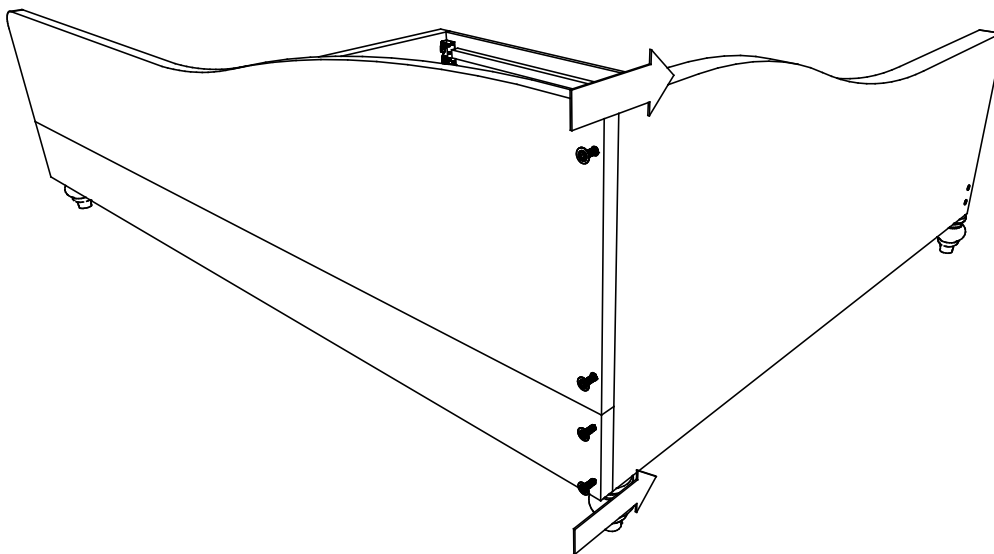

- Connect the TOP RIGHT SIDERAIL and BOTTOM RIGHT SIDERAIL (D1 & D2) to the HeadBoard (A) by use Bolt (2) fitted with Flat Washer (5). Then tighten bolts fully.

STEP 9:

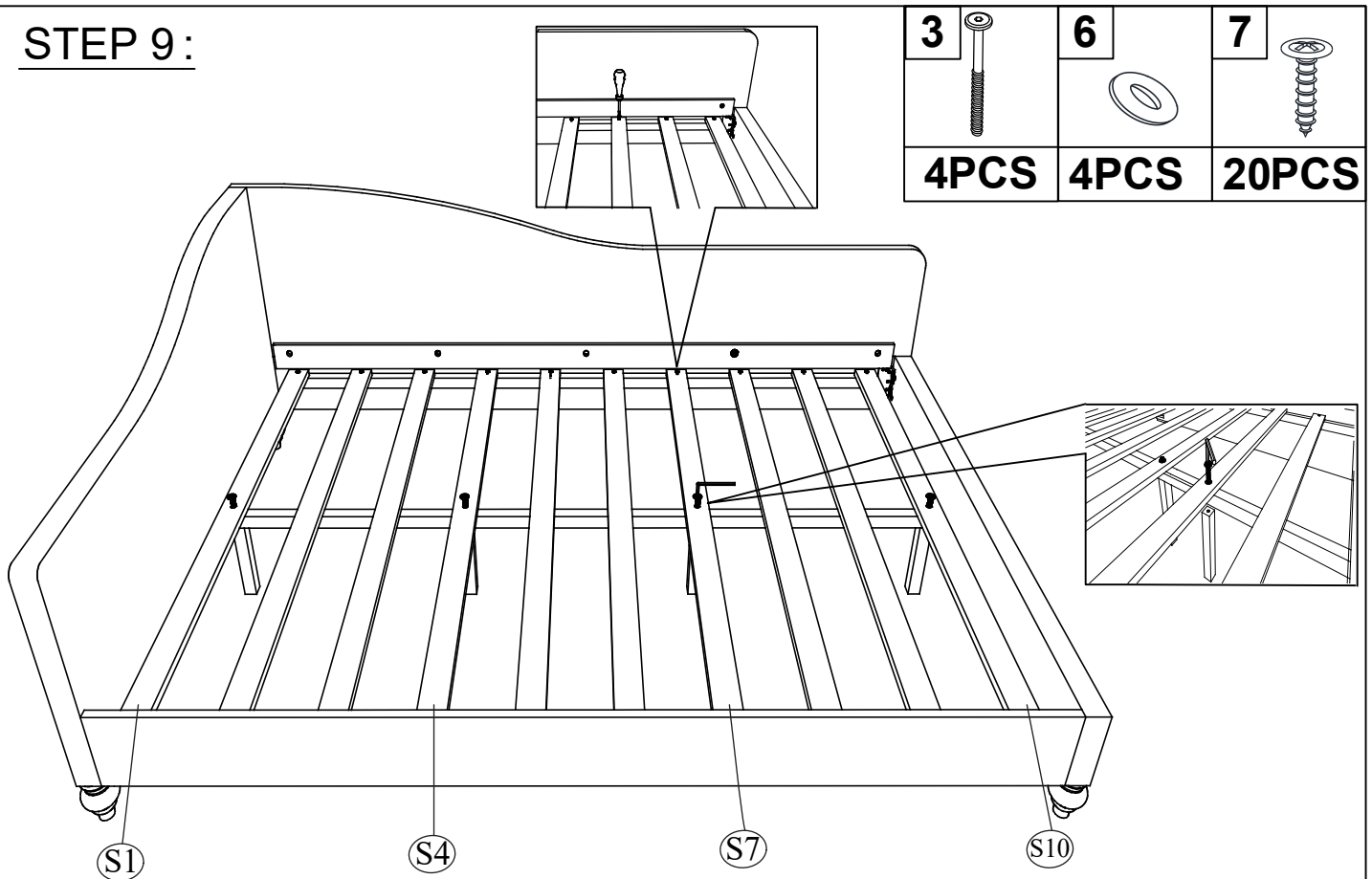

- Set Bolt (3) into Flat Washer (6), then pass assembled Bolts through Slat (S1,S4,S7,S10) and Center Support Bar (E) in turn, fit into Center Support Legs (G) then tighten with Allen Key (1).
- Use the ScrewDriver to install the Screw (7) into the hole on 2 heads of the Slat (F).

STEP 10:

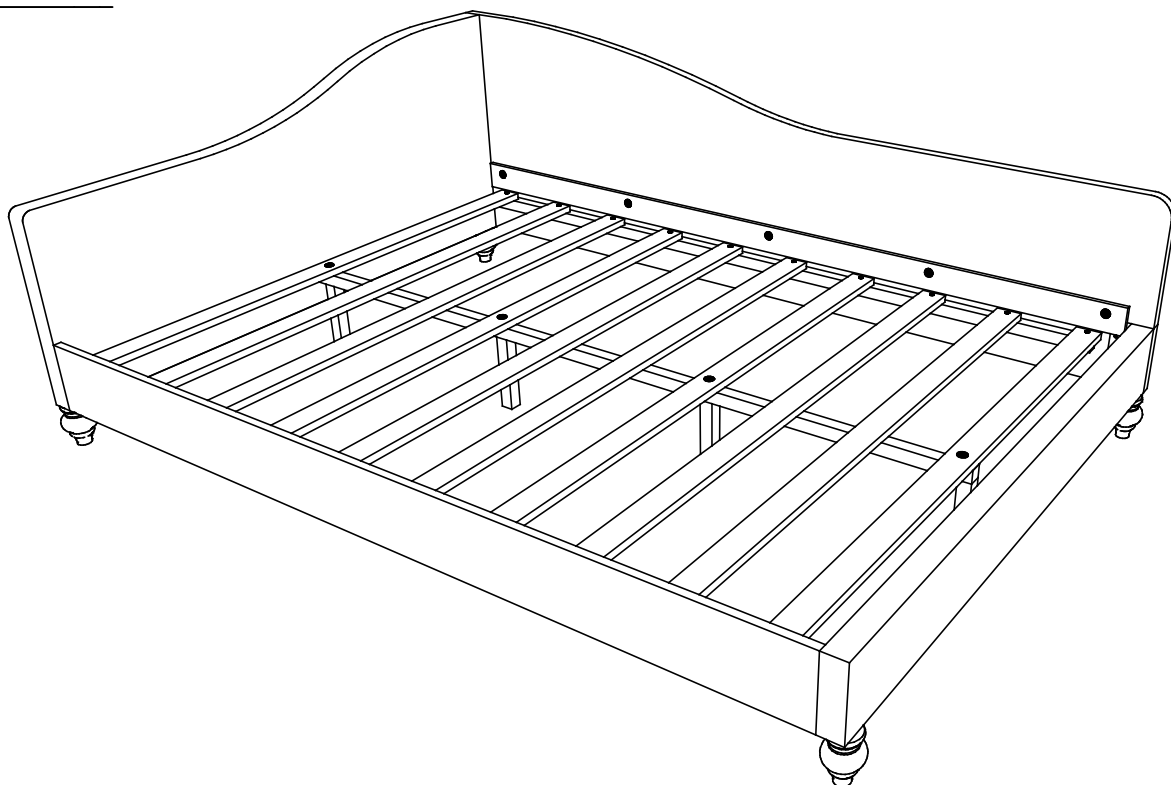

THE BED IS COMPLETE !

