

INSTALLATION INSTRUCTION

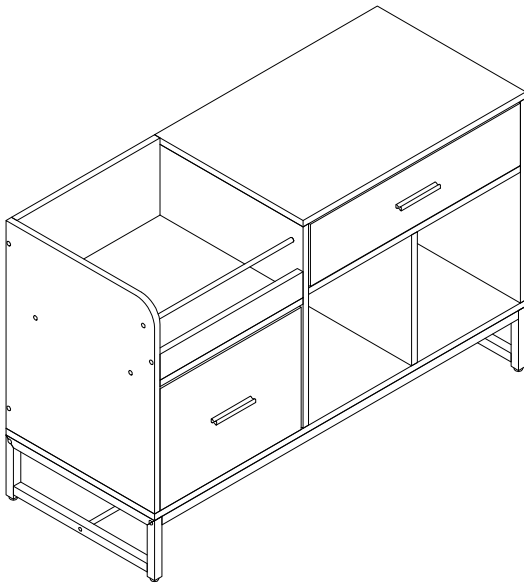

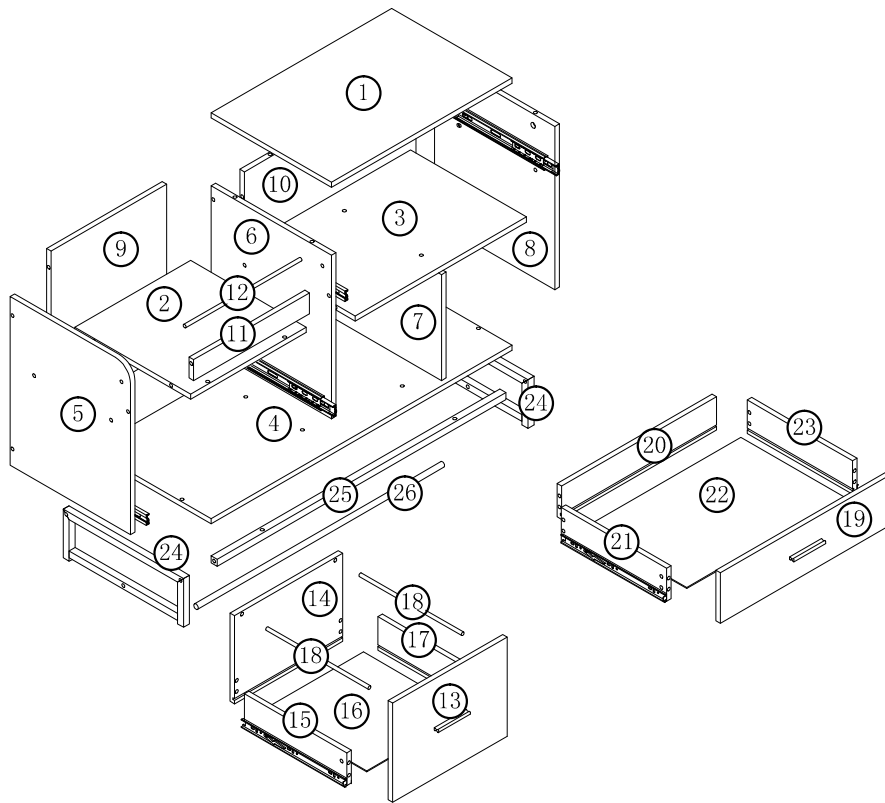





Notes: Don't tighten screws completely at first , just in case parts were assembled wrong and need disassembled. Tighten screws at last when all parts are put together.

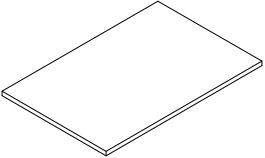
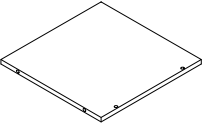
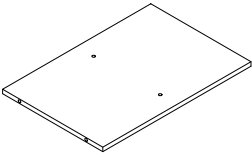
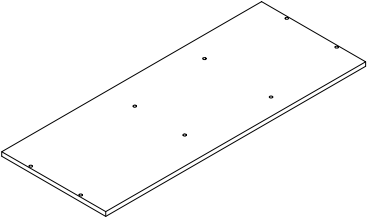
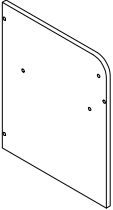
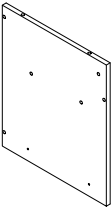
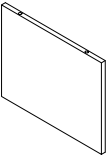
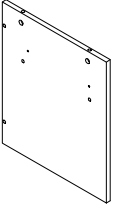
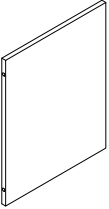
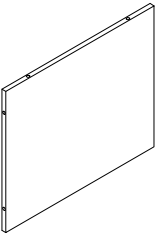
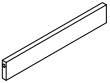

No.	PICTURE	SIZE	QTY	No.	PICTURE	SIZE	QTY
A			M6*25 4	H		M6*20 2	
B			M6*30 6	I			4
C			M6*40 4	J			4
D			ST7*40 30			→ 22	1
E			M6*35 22				
F			ST3.5*14 16				
G	X2	X1	M4*18 2				1

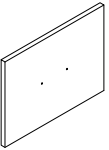
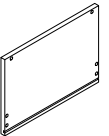
ASSEMBLY

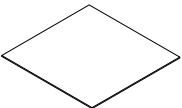
INSTRUCTION

<p>①</p>  <p>X1</p>	<p>②</p>  <p>X1</p>	<p>③</p>  <p>X1</p>
<p>④</p>  <p>X1</p>	<p>⑤</p>  <p>X1</p>	<p>⑥</p>  <p>X1</p>
<p>⑦</p>  <p>X1</p>	<p>⑧</p>  <p>X1</p>	<p>⑨</p>  <p>X1</p>
<p>⑩</p>  <p>X1</p>	<p>⑪</p>  <p>X1</p>	<p>⑫</p>  <p>X1</p>
<p>⑬</p>  <p>X1</p>	<p>⑭</p>  <p>X1</p>	<p>⑮</p>  <p>X1</p>
<p>⑯</p>  <p>X1</p>	<p>⑰</p>  <p>X1</p>	<p>⑱</p>  <p>X2</p>

INSTALLATION INSTRUCTION

19

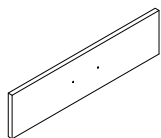

X1

20

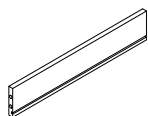

X1

21

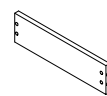

X1

22

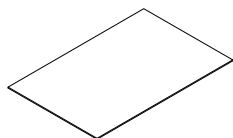

X1

23

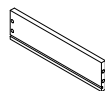

X1

24

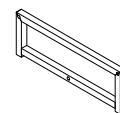

X2

25

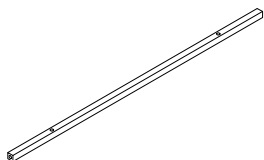

X2

26

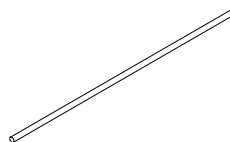

X1

STEP 1

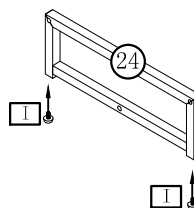
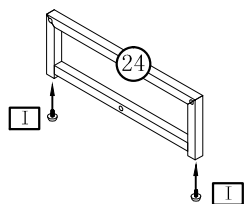

1





X4

INSTALLATION INSTRUCTION

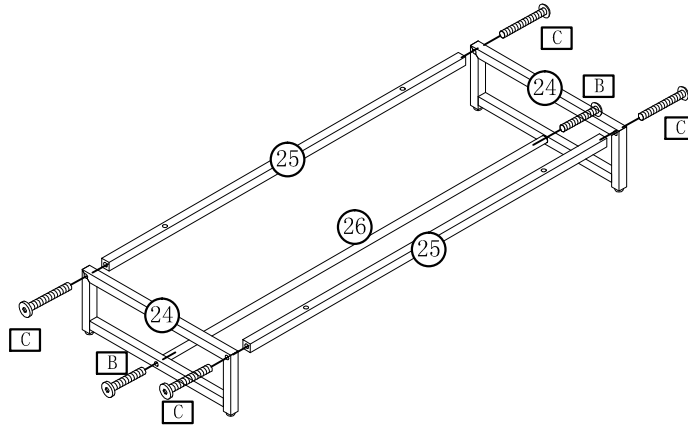

STEP 2



B	M6*30
	X2
C	M6*40
	X4

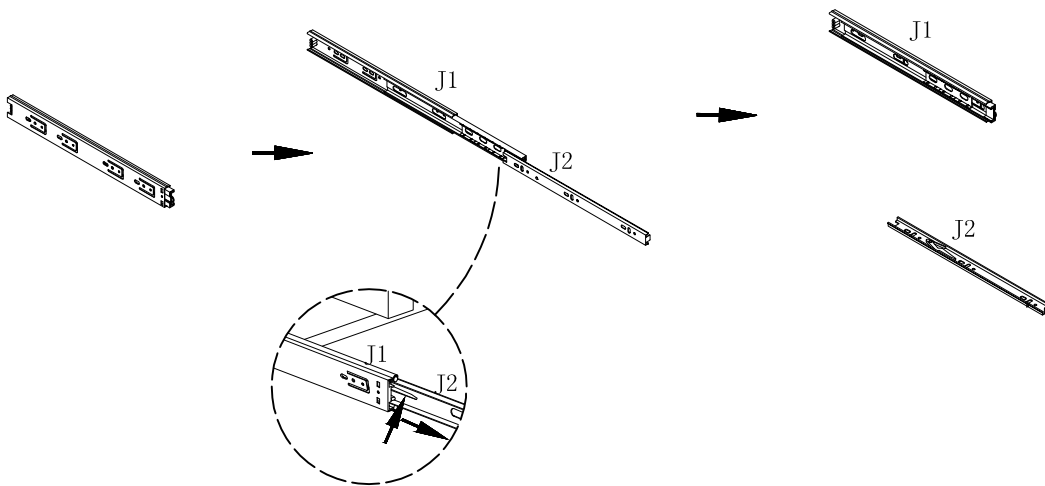

STEP 3

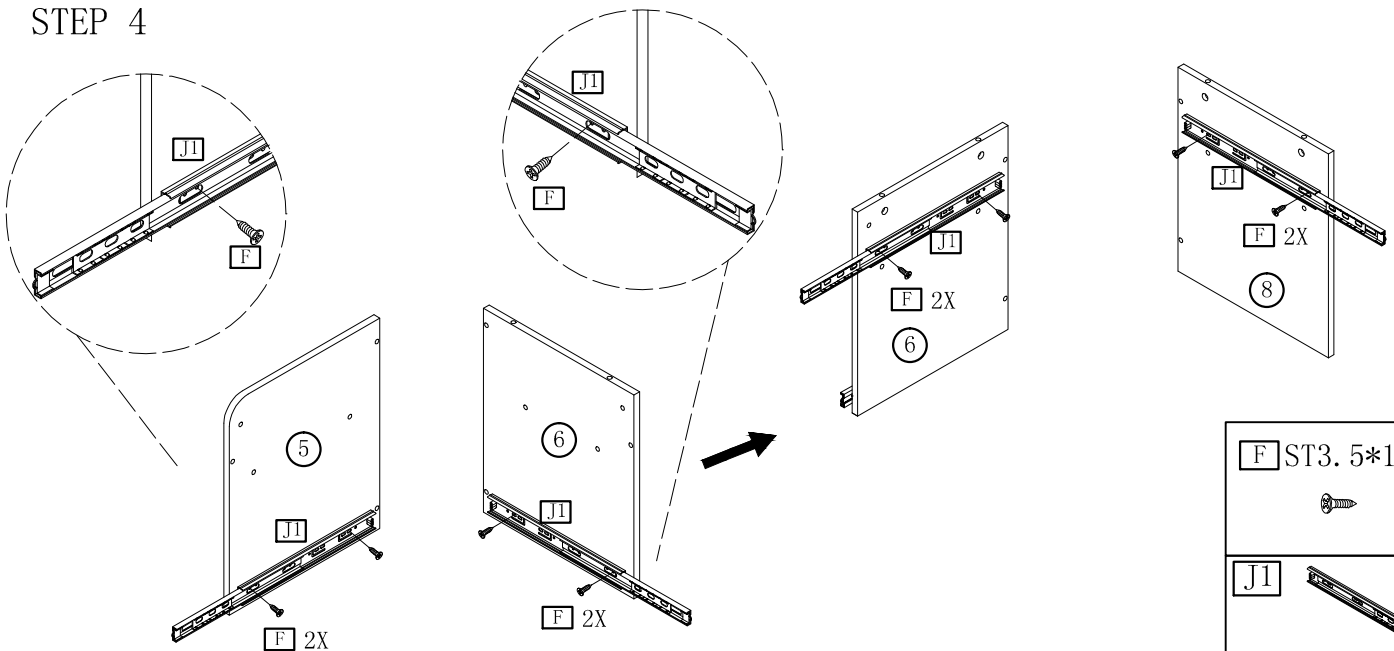

J1		X4
J2		X4

STEP 4



F	ST3. 5*14	
	X8	
J1		X4

INSTALLATION INSTRUCTION

STEP 5

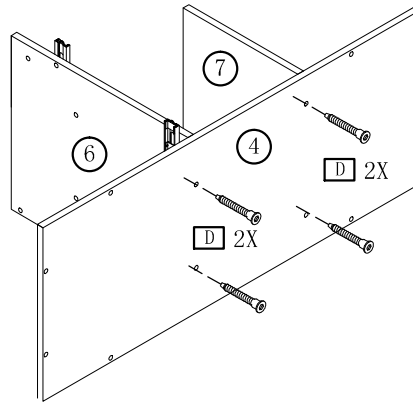

D ST7*40



X4

STEP 6

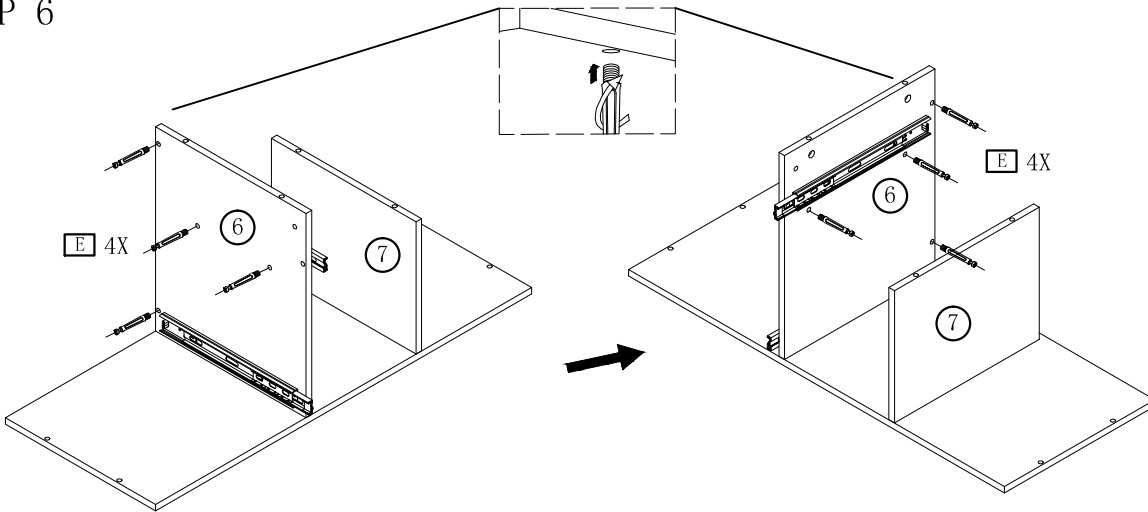

E M6*35



X8

STEP 7

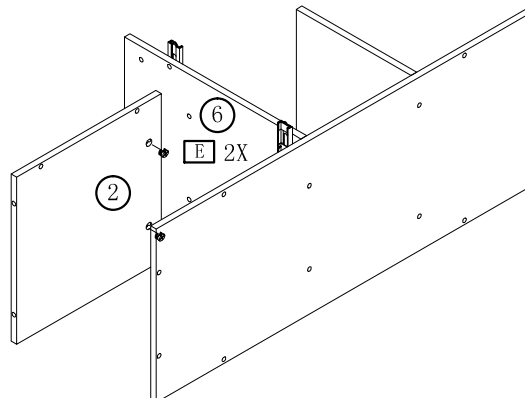

E M6*35



X2

INSTALLATION INSTRUCTION

STEP 8

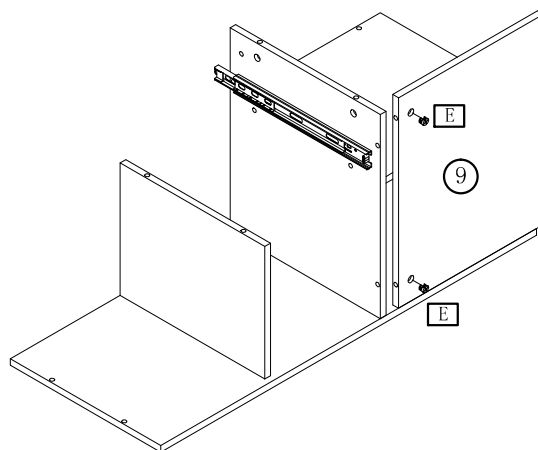

E M6*35
 X2

STEP 9

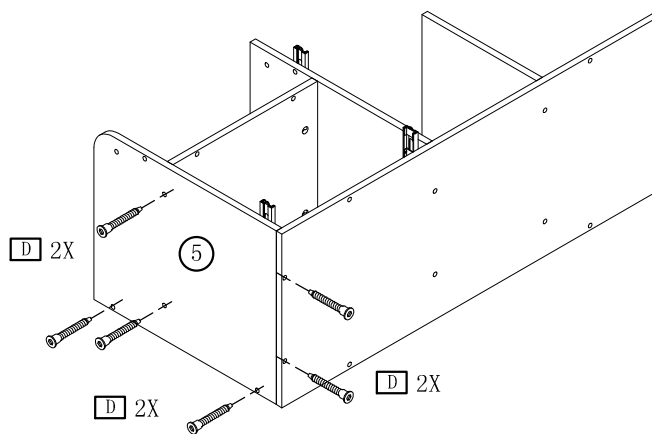

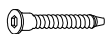
D ST7*40
 X6

STEP 10

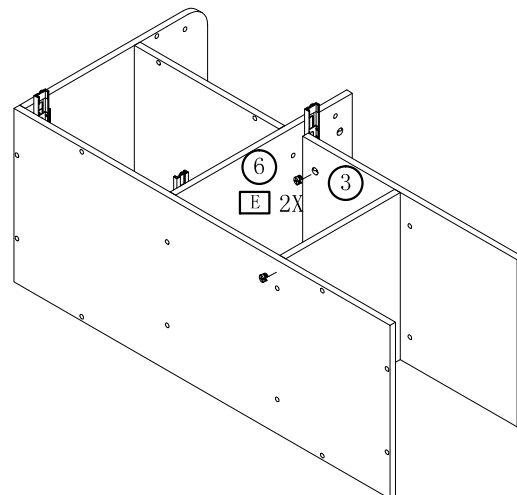

E M6*35
 X2

INSTALLATION INSTRUCTION

STEP 11

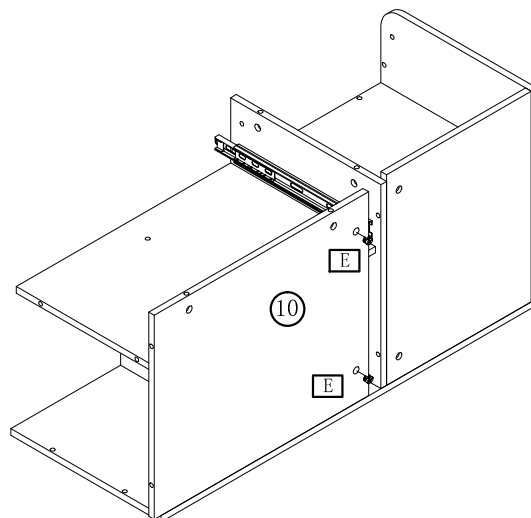

E M6*35

X2

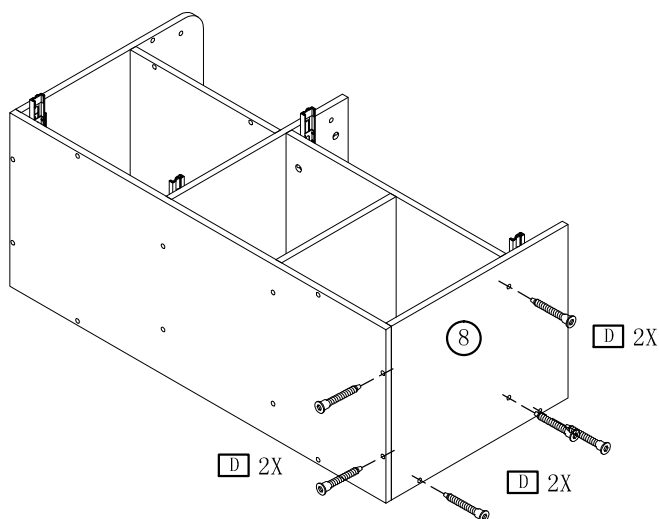
STEP 12

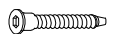

D ST7*40

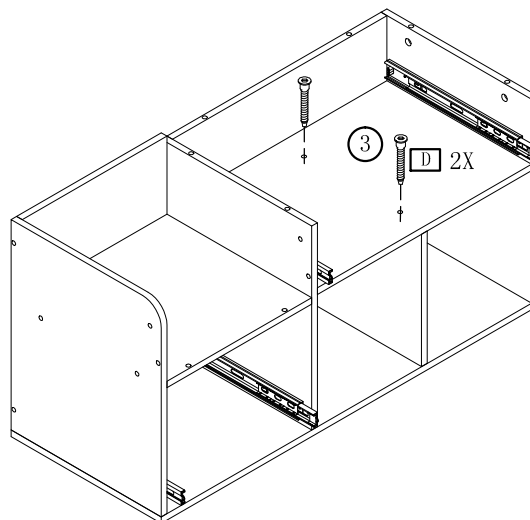
X6

STEP 13

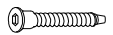

D ST7*40

X2

INSTALLATION INSTRUCTION

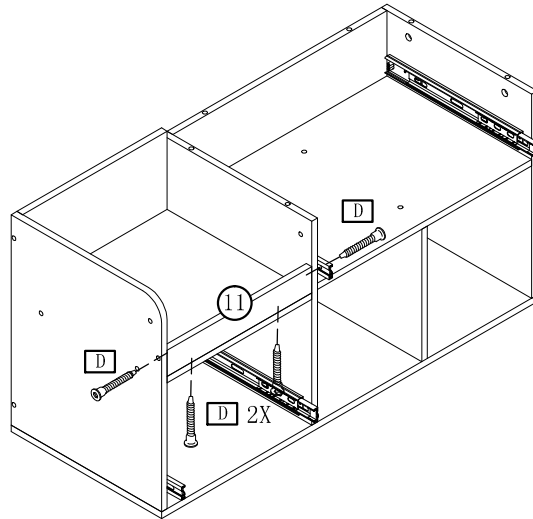
STEP 14



D ST7*40



X4

STEP 15

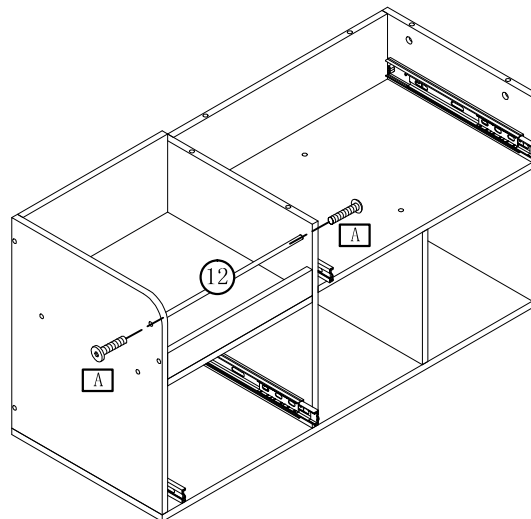

A M6*25



X2

STEP 16

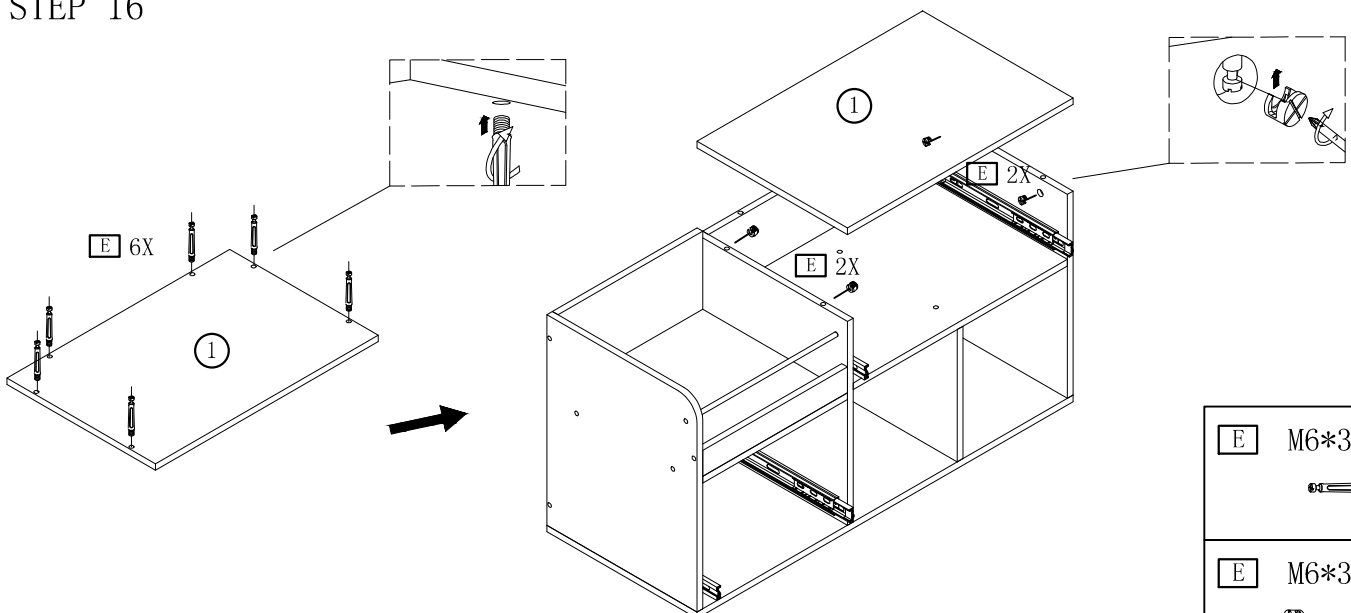

E M6*35



X6

E M6*35



X4

INSTALLATION INSTRUCTION

STEP 17

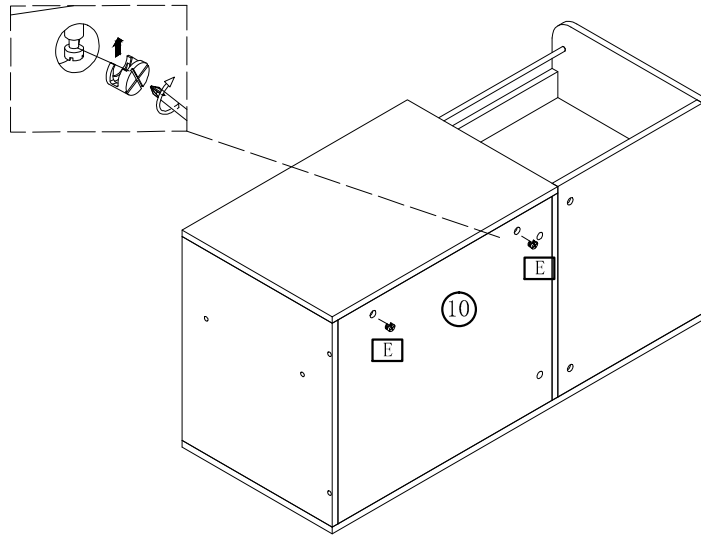

E M6*35
 X2

STEP 18

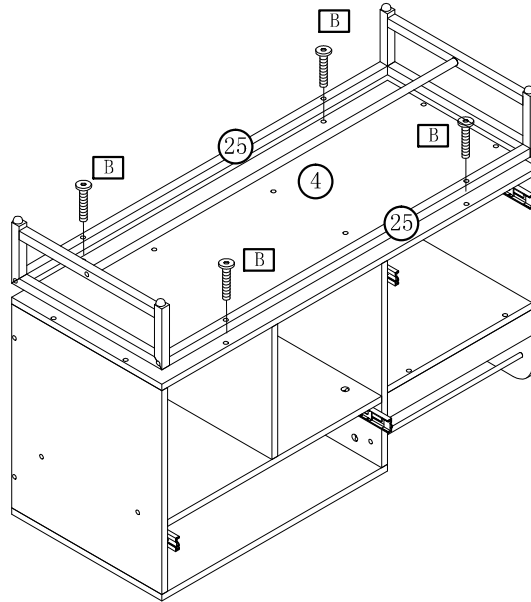

B M6*30
 X4

STEP 19

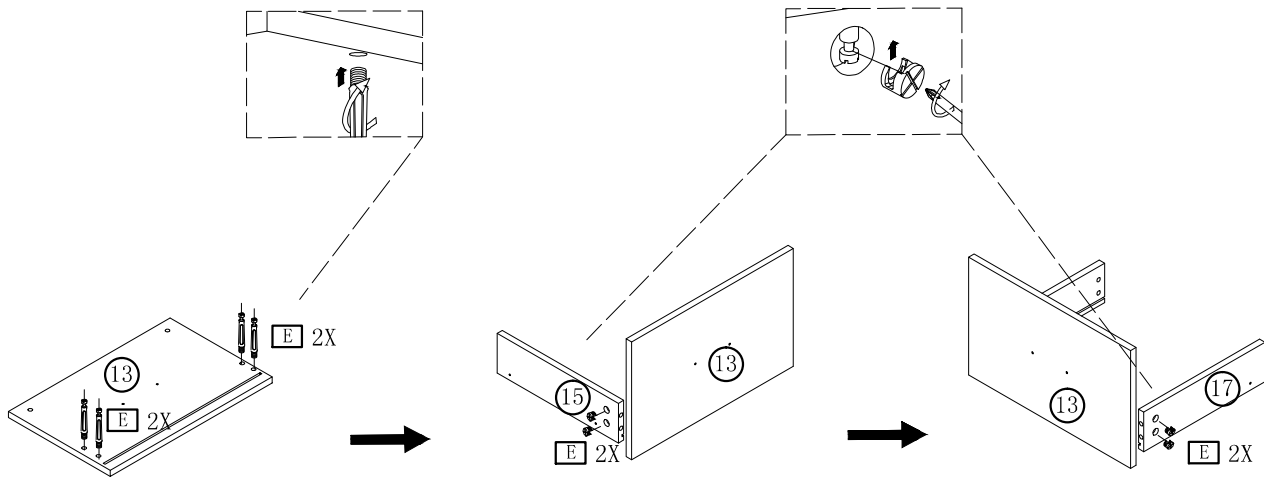

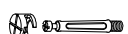
E M6*35
 X4

INSTALLATION INSTRUCTION

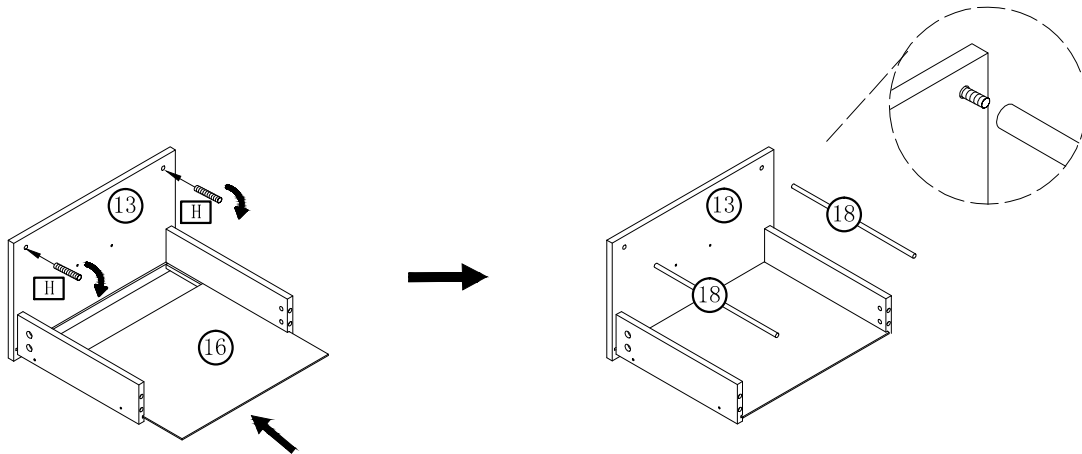

STEP 20



H	M6*20
	
	X2

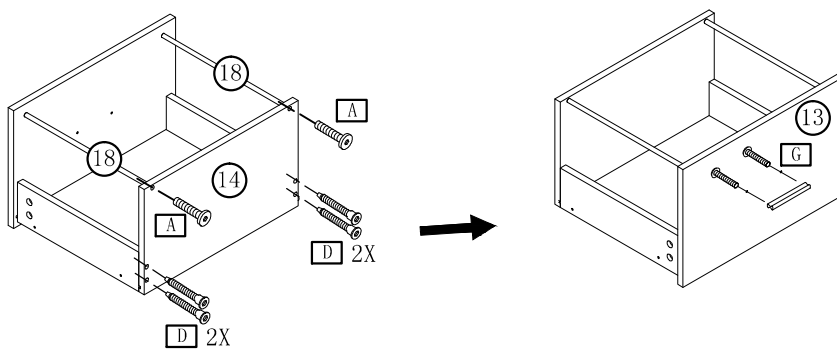

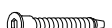
STEP 21

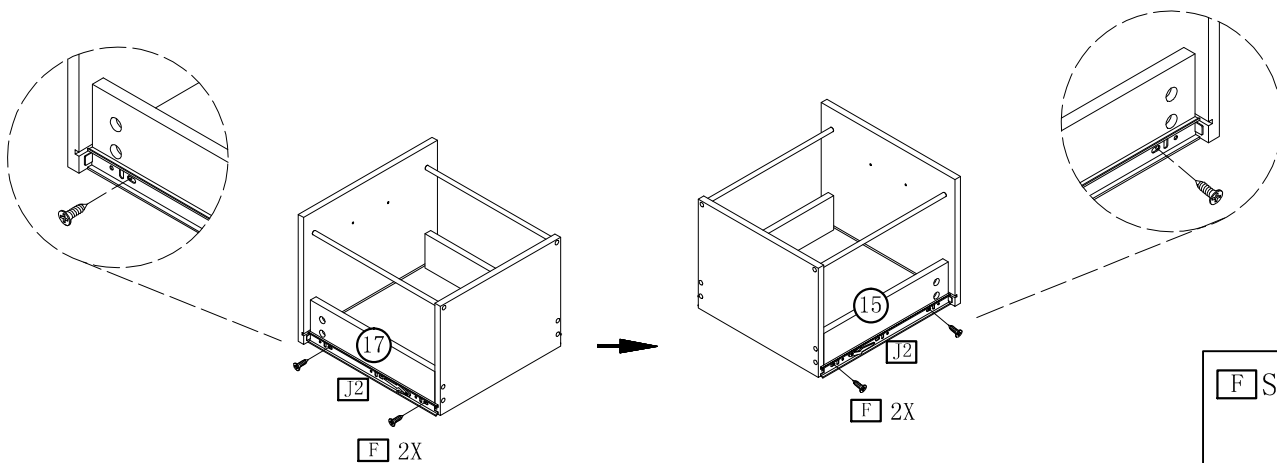

A	M6*25
	
	X2
D	ST7*40
	
	X4
G	M4*18
	 
	X1

STEP 22



F	ST3.5*14
	
	X4
J2	
	X2

INSTALLATION INSTRUCTION

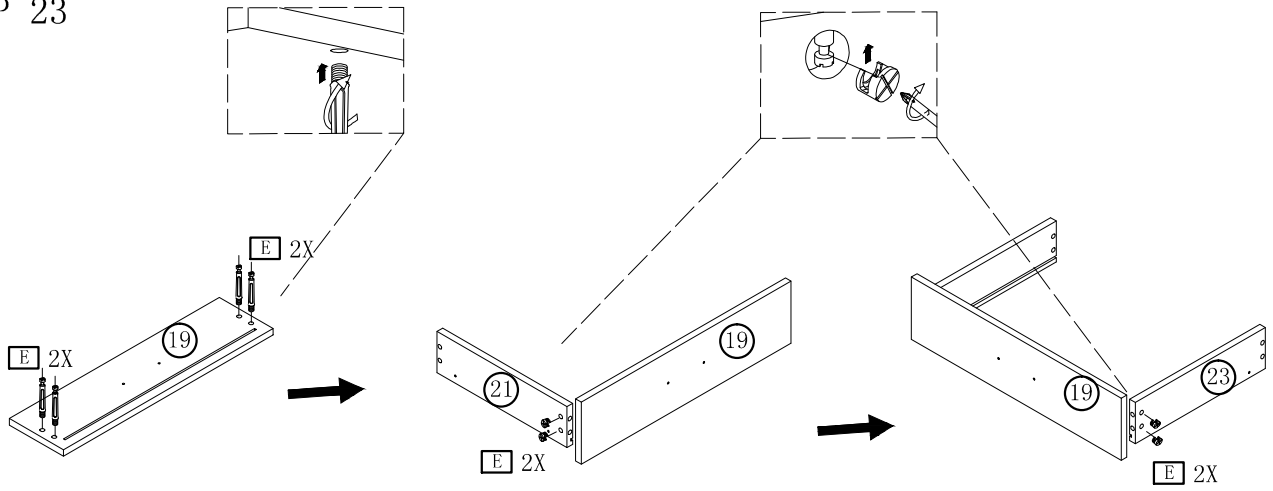

STEP 23



E	M6*35
	
X4	

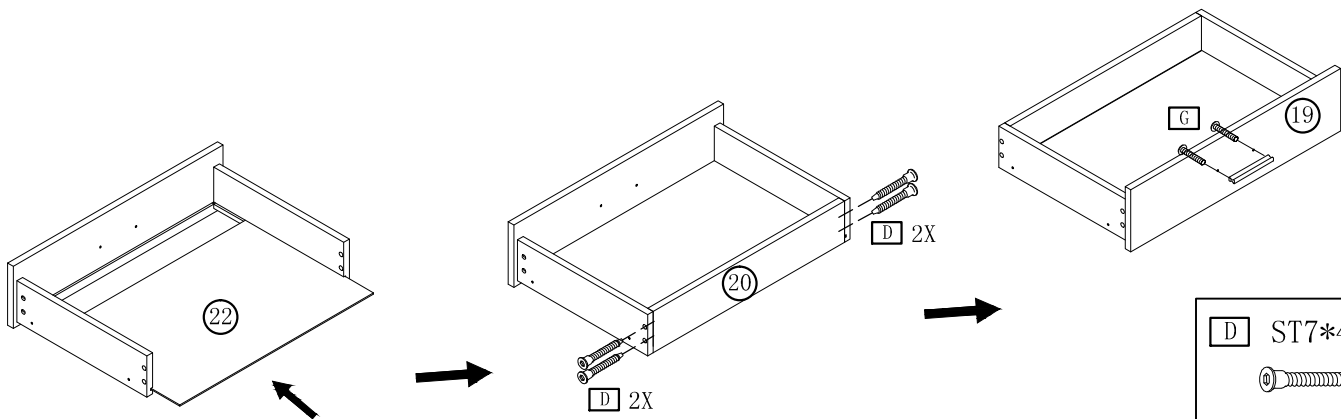

STEP 24

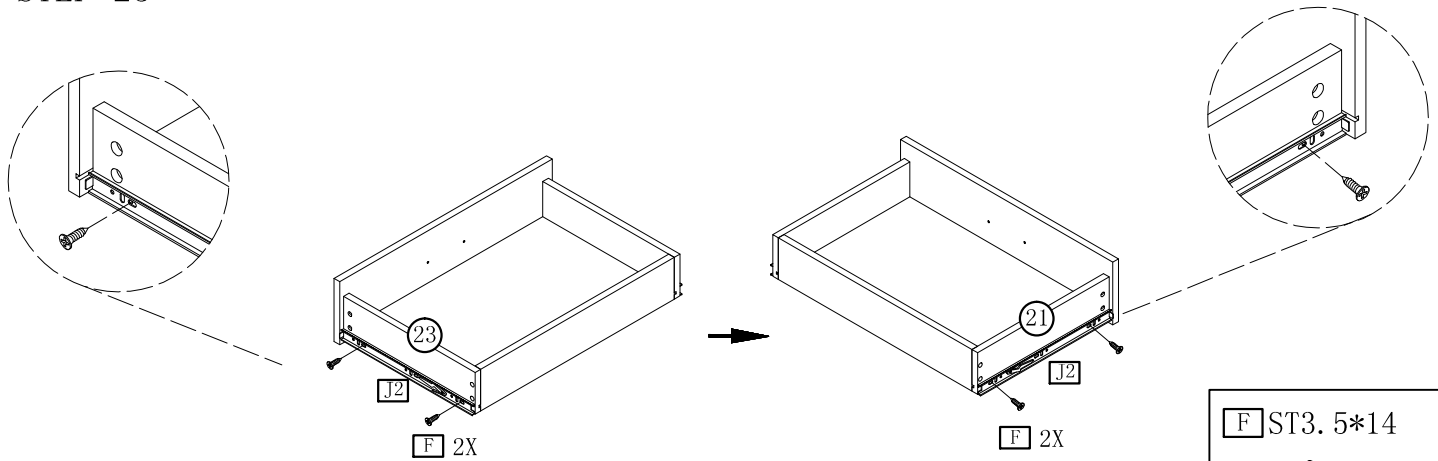

D	ST7*40
	
X4	
G	M4*18
	
X1	

STEP 25



F	ST3.5*14
	
X4	
J2	
X2	

INSTALLATION INSTRUCTION

STEP 26

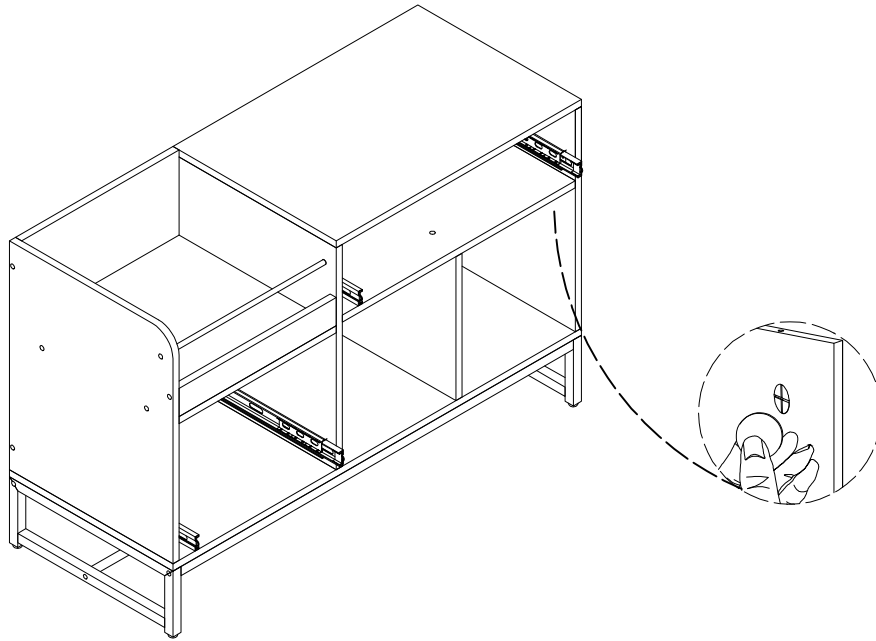

STEP 27

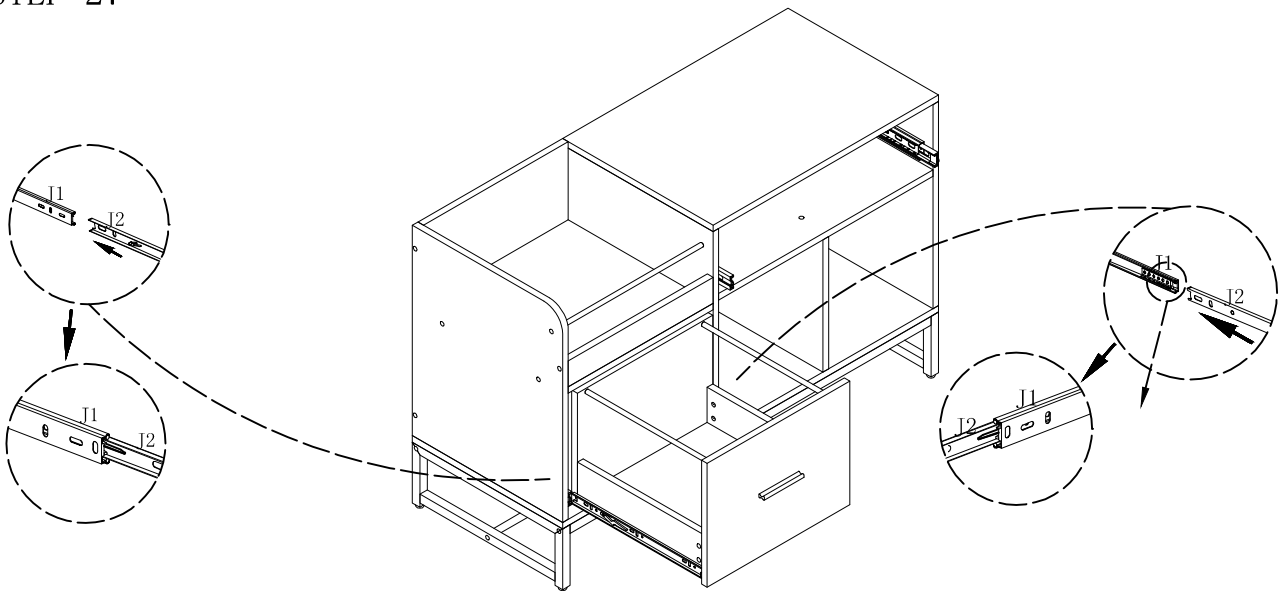

STEP 28

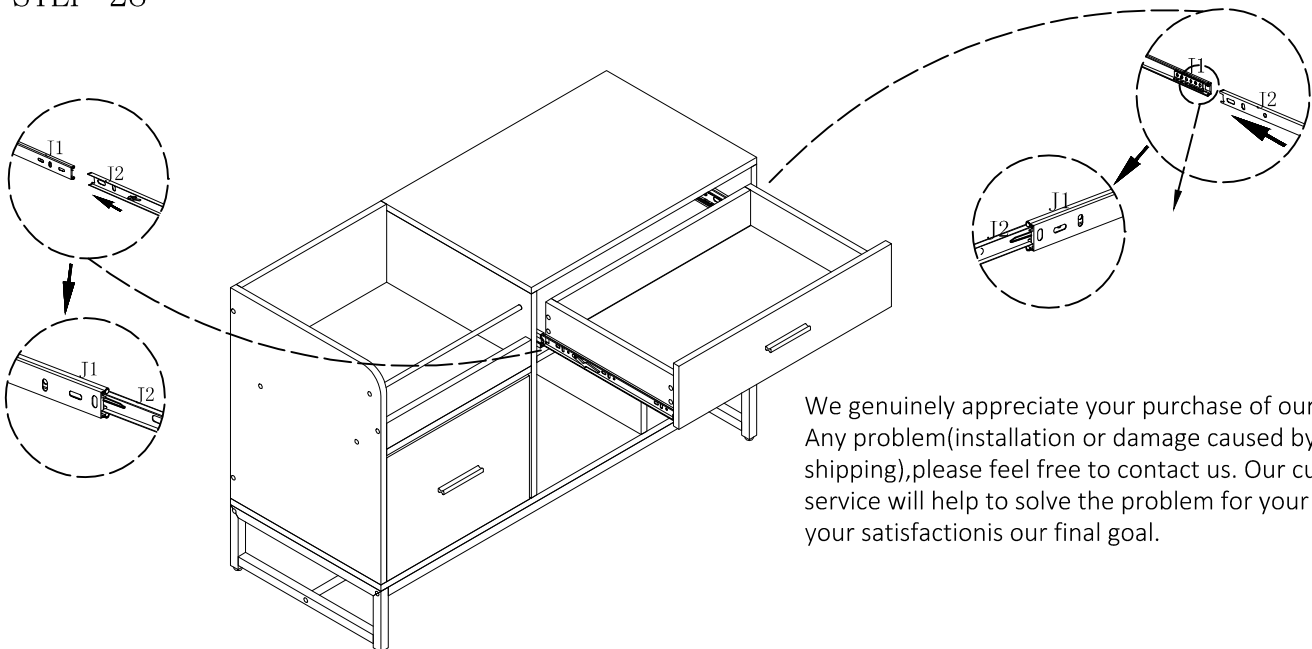

We genuinely appreciate your purchase of our product. Any problem (installation or damage caused by shipping), please feel free to contact us. Our customer service will help to solve the problem for your ASAP, as your satisfaction is our final goal.