

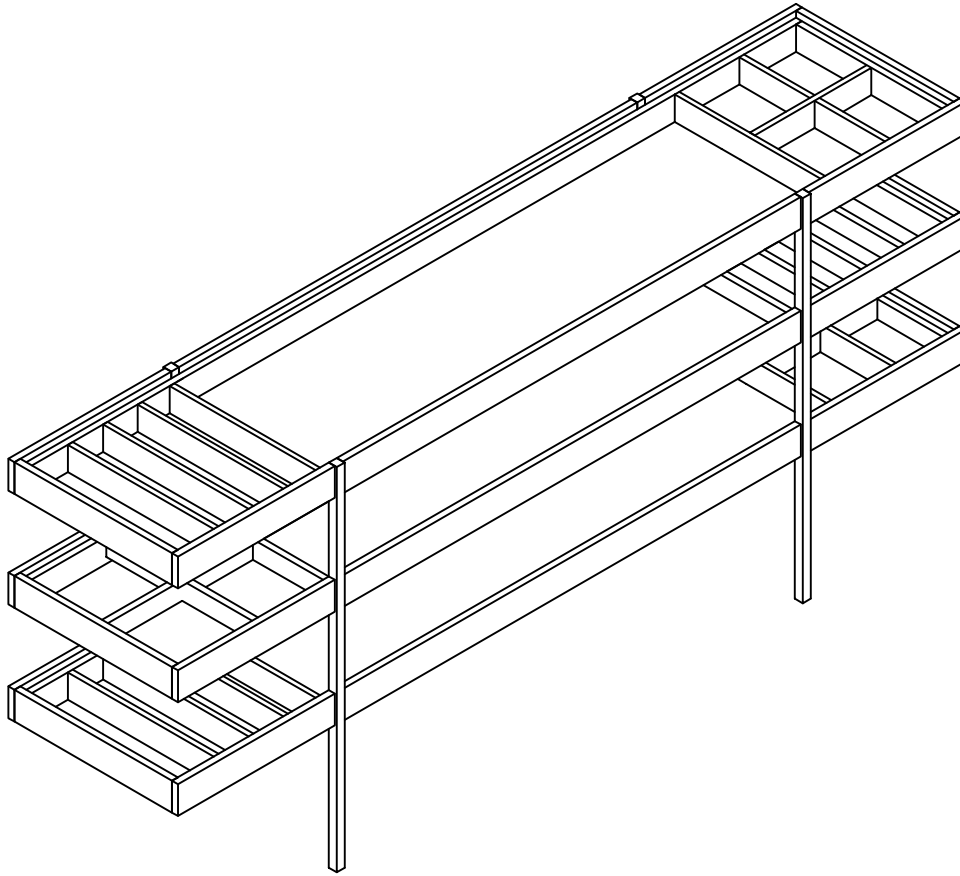

ZWJ-605 3-Tier Storage Shelf

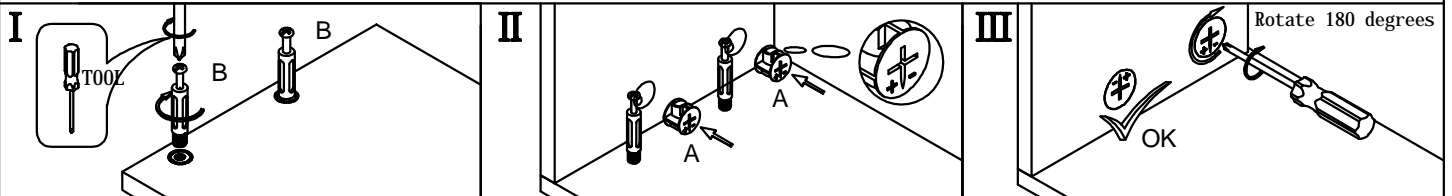

Disassembly and installation of accessories

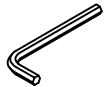

A	48PCS	B	1 PCS
			
M6*30		5mm	

Parts list

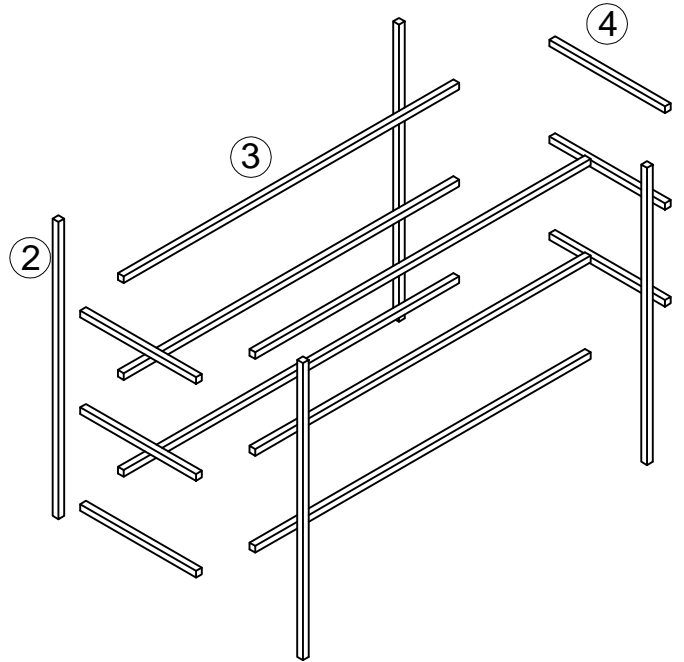
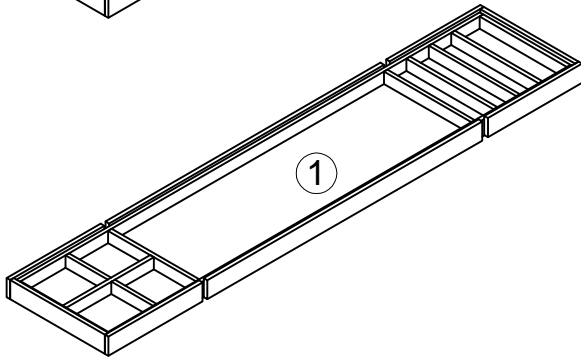
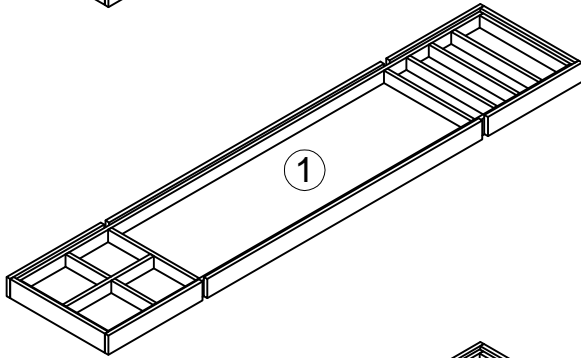
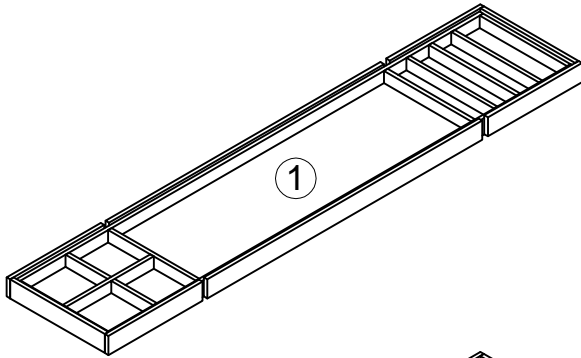

1

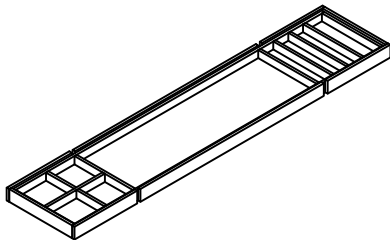

3PC

2



4PC

3

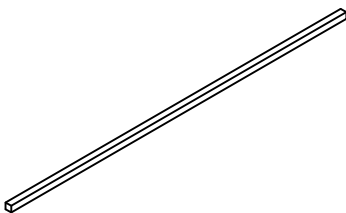

6PC

4

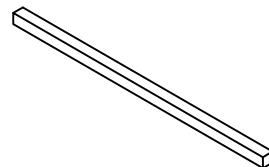

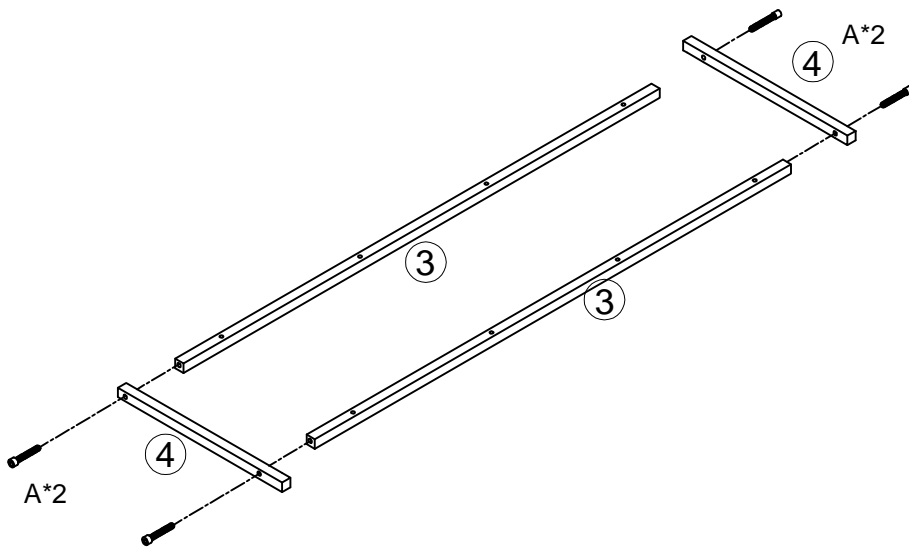

6PC

STEP 1

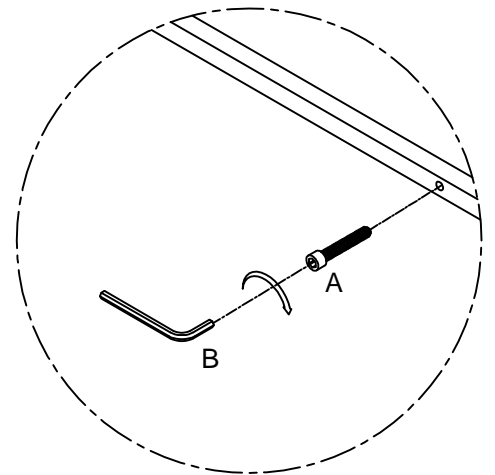

Attach hardware 4 to both sides of hardware 3 using fitting A; as shown, use fitting B to assist the installation of fitting A.
 Note: the long-side holes of hardware 3 should face upward.



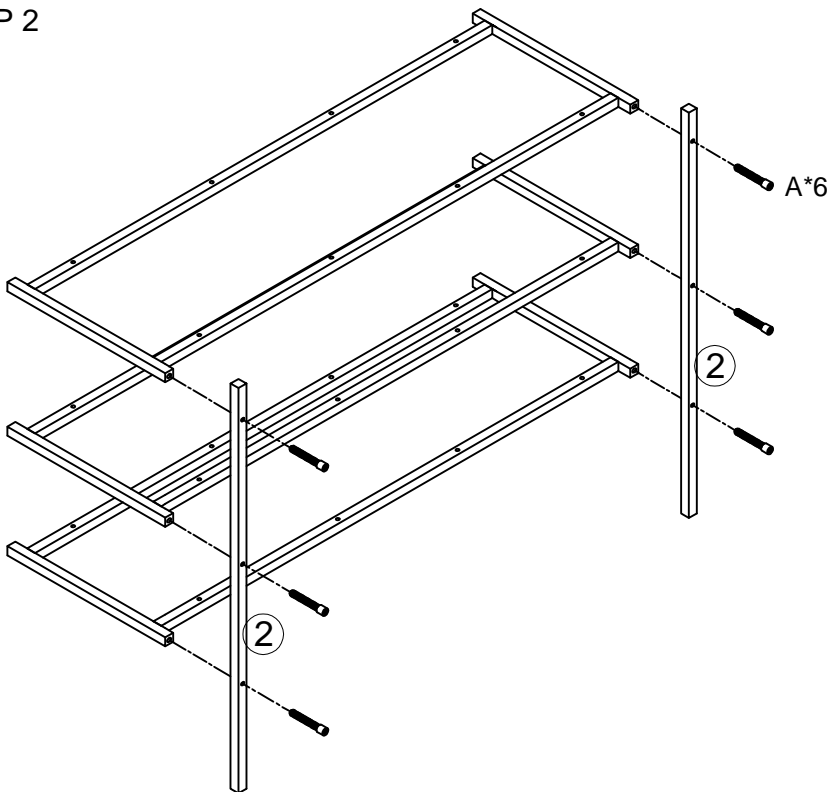

A 12PCS	B 1 PCS
	
M6*30	5mm

STEP 2

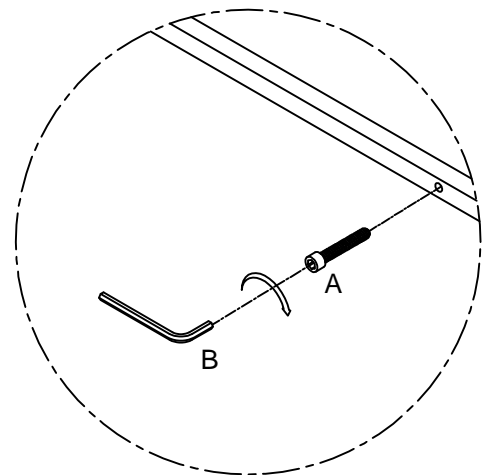

Attach hardware 2 to the frame assembled in the previous step using fitting A.





A 6PCS	B 1 PCS
	
M6*30	5mm

On the same side of hardware 3, as shown, use fitting B to assist the installation of fitting A.

STEP 3

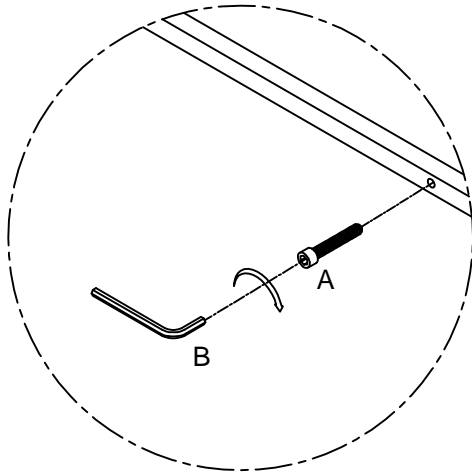
Flip the hardware frame assembled in the previous step, place panel 1 onto the top of the hardware frame, and secure it with fitting A; as shown, use fitting B to assist the installation of fitting A.



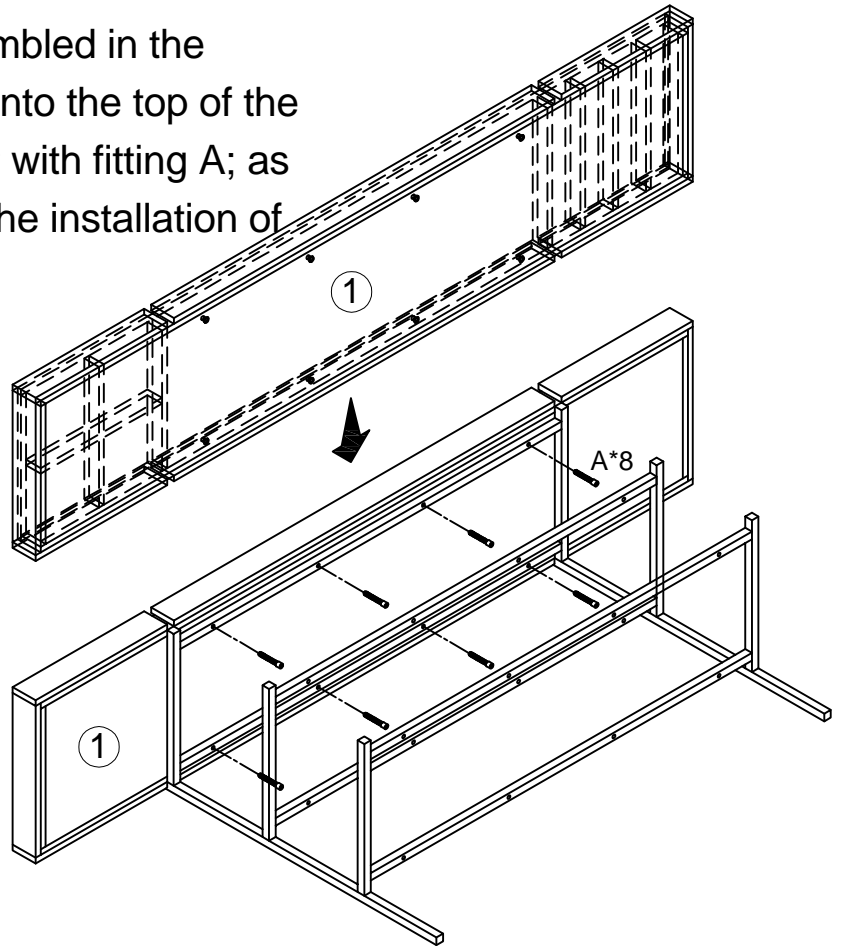

A 8PCS	B 1 PCS
	
M6*30	5mm

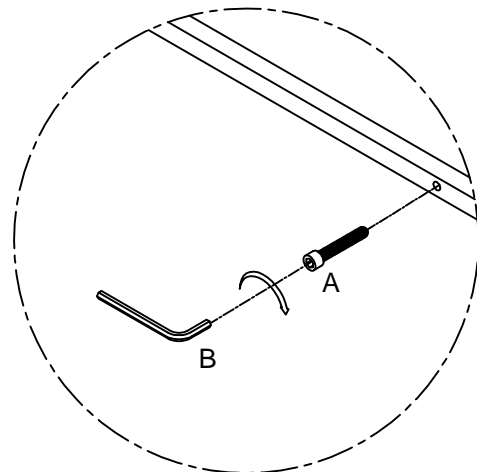

STEP 4

Place assembled panel 1 onto the middle hardware frame and secure it with fitting A; as shown, use fitting B to assist the installation of fitting A.



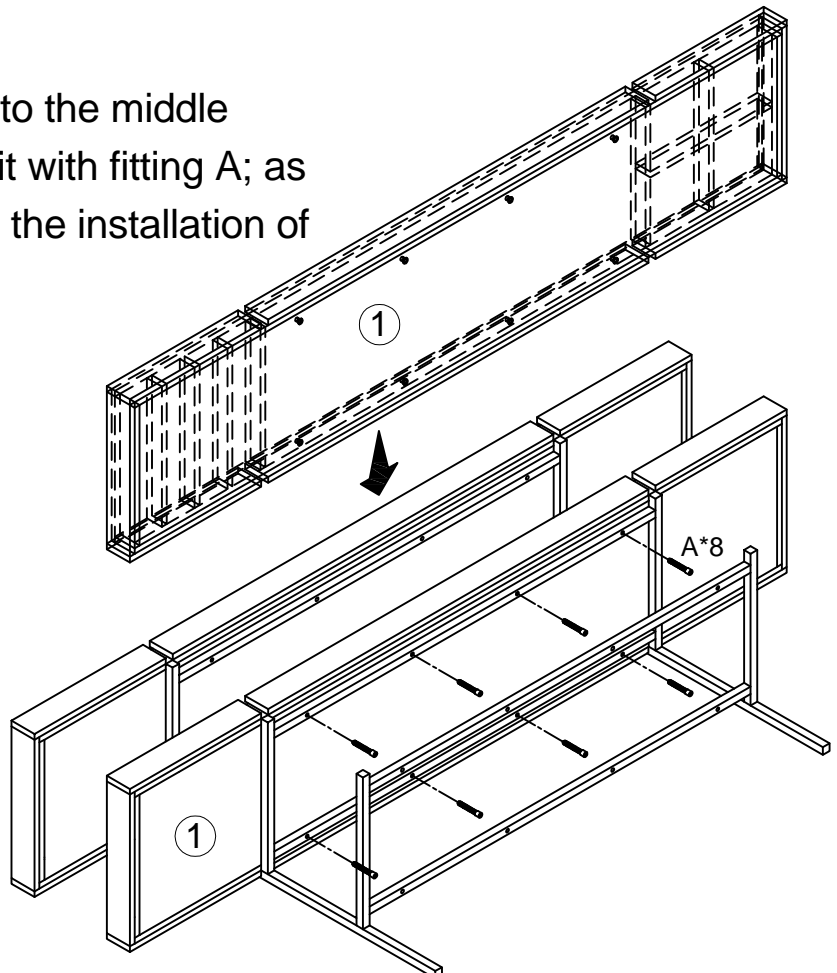

A 8PCS	B 1 PCS
	
M6*30	5mm

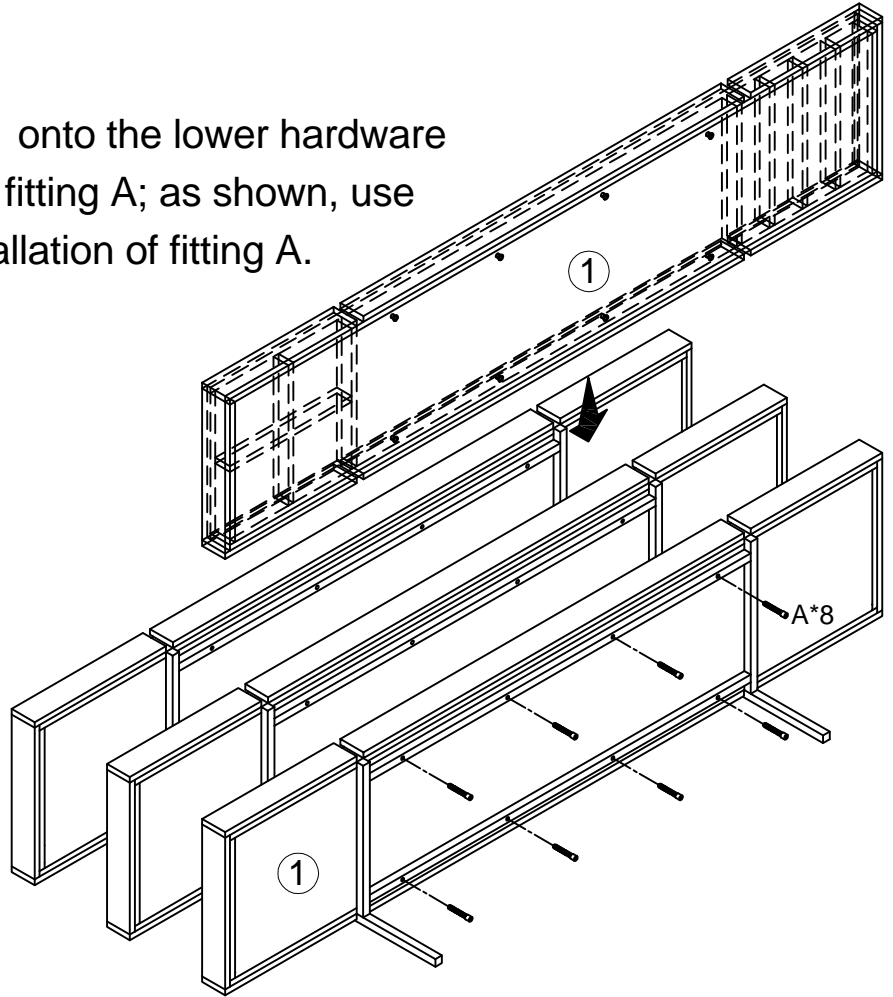
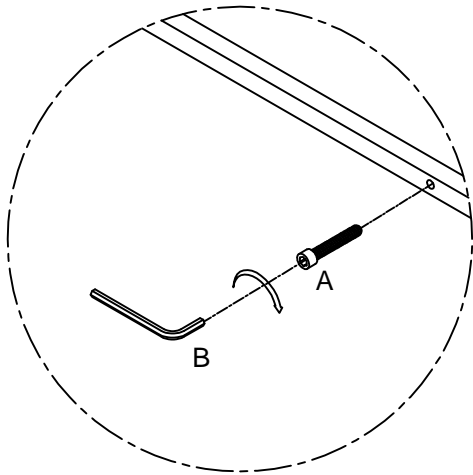

STEP 5

Place assembled panel 1 onto the lower hardware frame and secure it with fitting A; as shown, use fitting B to assist the installation of fitting A.





A 8PCS	B 1 PCS
	
M6*30	5mm

STEP 6

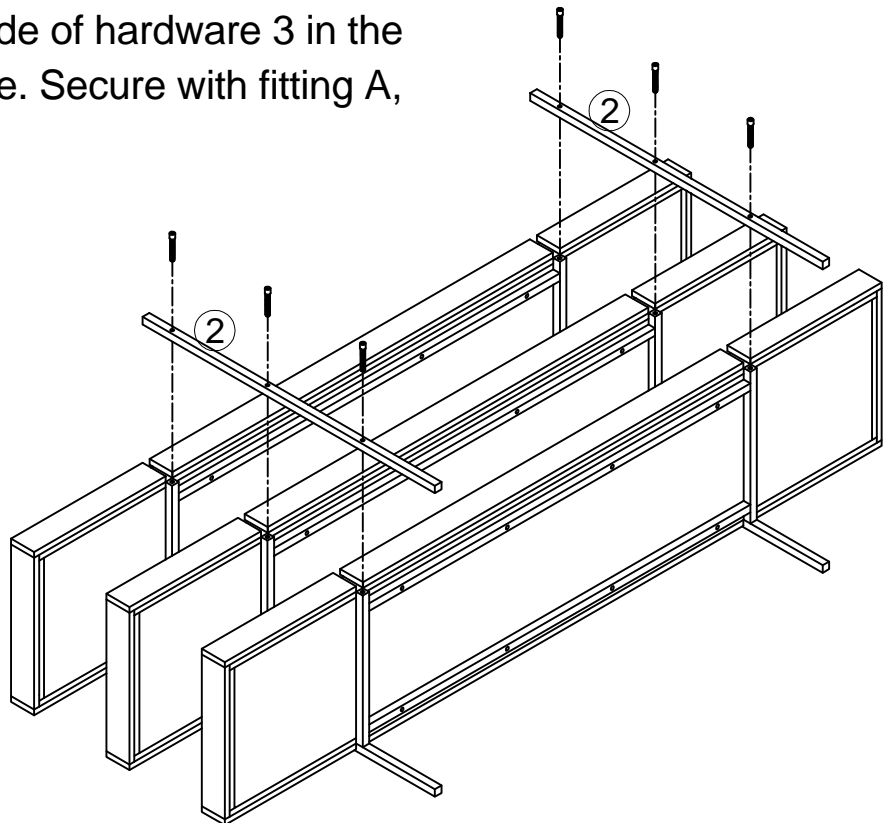
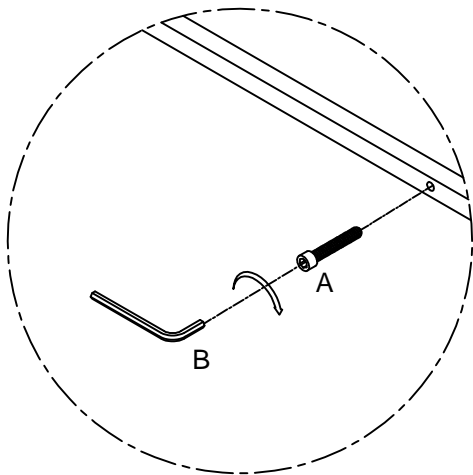
Attach hardware 2 to one side of hardware 3 in the previously assembled frame. Secure with fitting A, using fitting B as shown.



A 6PCS	B 1 PCS
	
M6*30	5mm

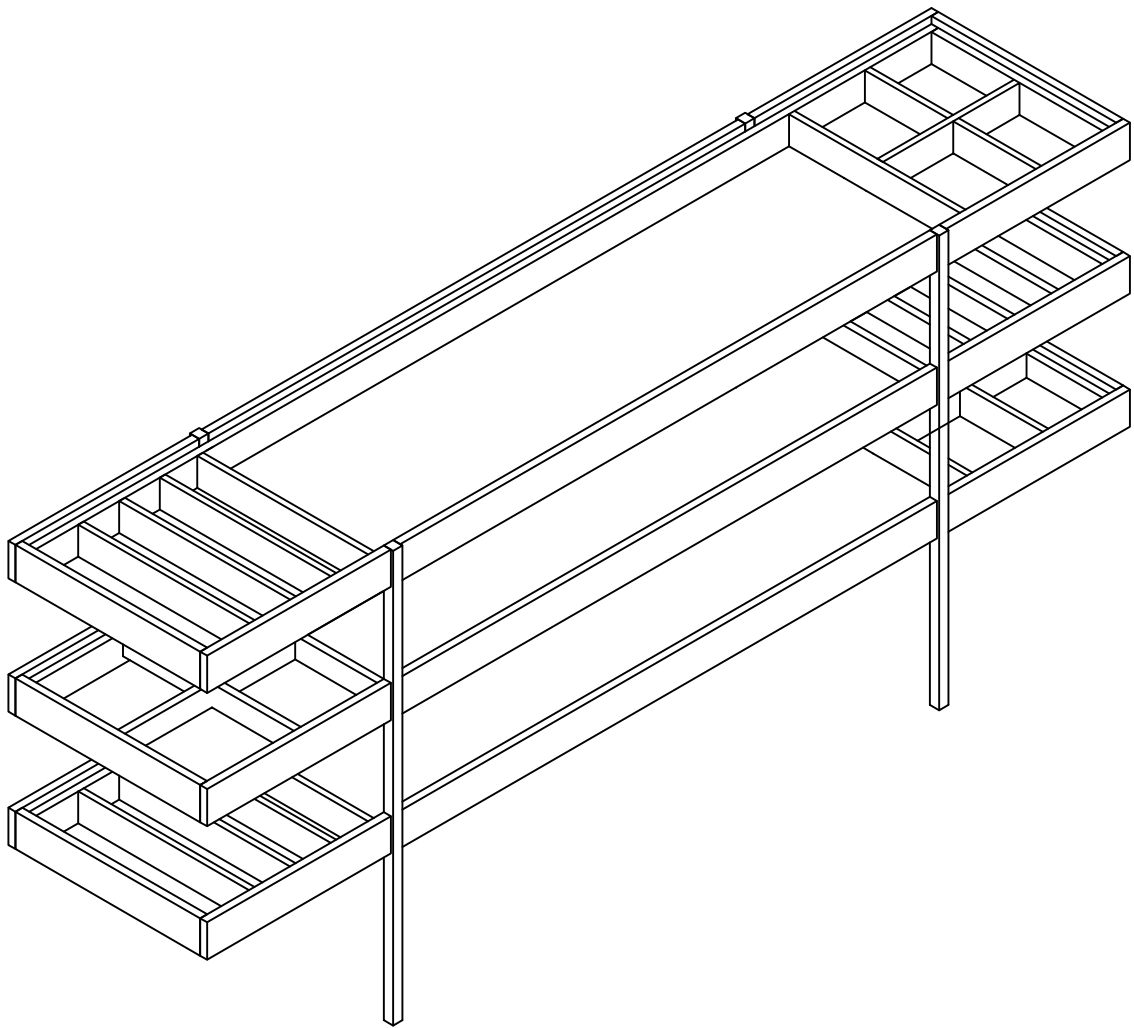

OK