

ASSEMBLY INSTRUCTIONS ROUND TABLE

Please read instructions carefully.

Remove all wrapping materials, staples and packing straps from the carton. Refer to Parts List and Hardware List and ensure they are complete before you start assembling. Place all wooden parts on a clean, flat and soft surface (e.g carpet or rug) to prevent parts from being scratched.

- CAUTIONS:
- 1) DO NOT FULLY TIGHTEN BOLTS AND NUTS UNTIL ALL PARTS HAVE BEEN ASSEMBLED.
 - 2) DO NOT OVER-TIGHTEN BOLTS AND NUTS UNTIL ALL PARTS HAVE BEEN ASSEMBLED.
 - 3) KEEP ALL HARDWARE PARTS OUT OF REACH CHILDREN.

	PARTS LIST	QTY.
P1	TABLETOP	1
P2	LEG	4
P3	PEDESTAL BASE (lower Half Lap)	1
P4	PEDESTAL BASE (upper Half Lap)	1
P5	MOUNTING PANEL	1

	HARDWARE LIST	QTY.
H1	M6 x 35mm JCBC SCREW 	4
H2	M6 x 60mm JCBC SCREW 	16
H3	SPRING WASHER 	4
H4	FLAT WASHER 	4
H5	ALLEN KEY 	1
H6	LEG GLIDE 	4



COMPLETE ASSEMBLY

STEP 1

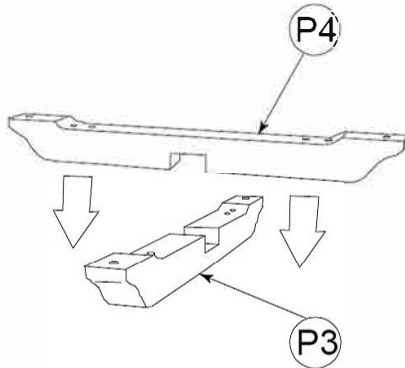

STEP 2

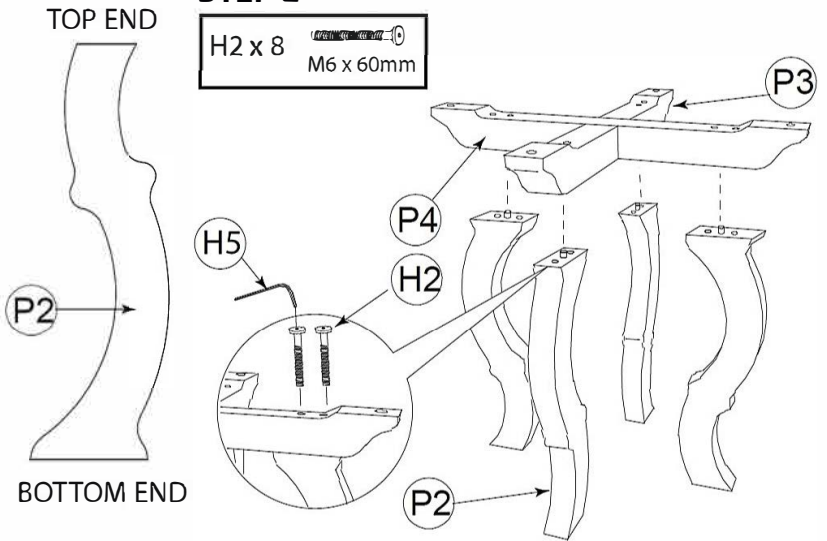

STEP 3

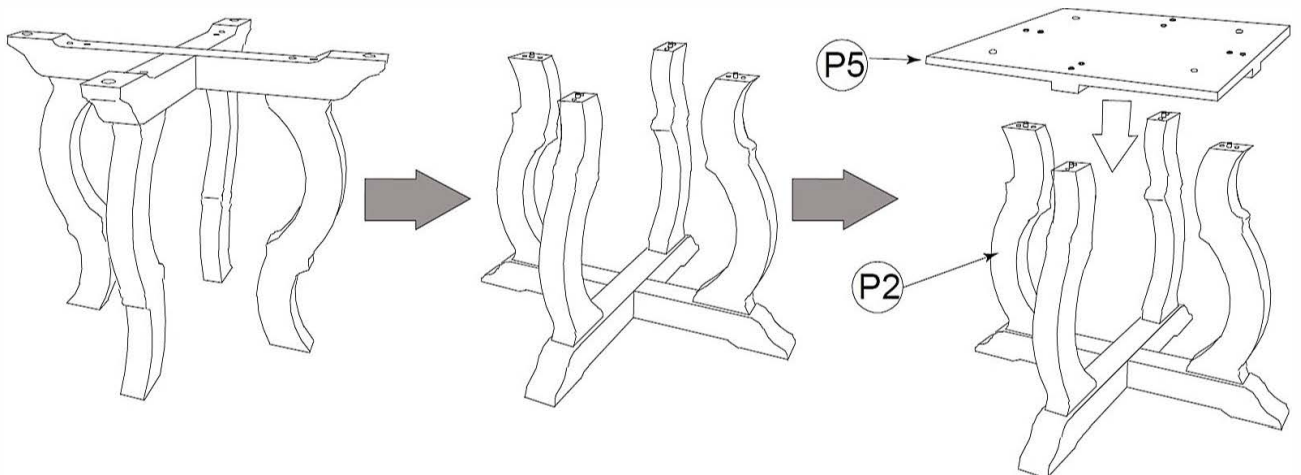

STEP 4

H2 x 8
M6 x 60mm

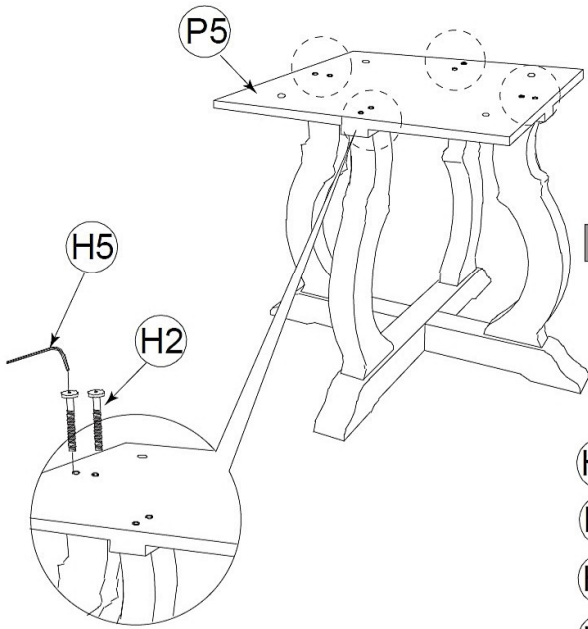

STEP 5

H1 x 4
M6 x 35mm

H3 x 4
H4 x 4

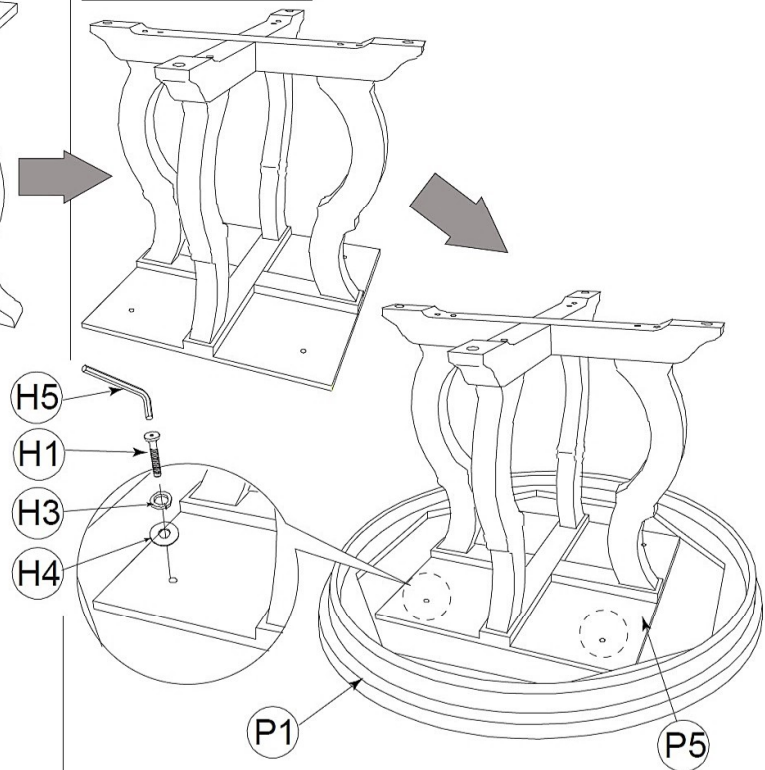

STEP 6

H6 x 4

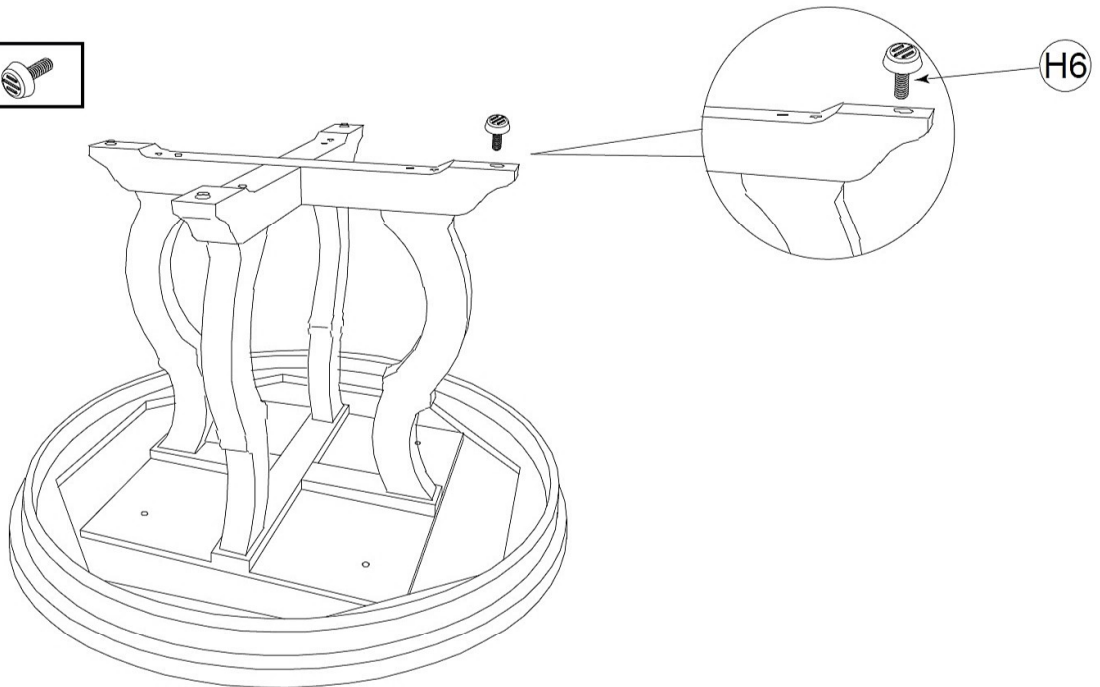

Carefully put the table upright by two or more adults person.

CARE AND MAINTENANCE

SAFETY - To avoid any risk of suffocation to children and animals, dispose off plastic bags immediately.

CLEANING - Clean with damp cloth and mild detergent. Do not use bleach or abrasive products.

FITTINGS - tighten bolts and nuts from time to time to ensure all parts of product are securely fitted.