

# BOOKSHELF

## Instruction Manual

Thank you for shopping with us!

We appreciate your purchase and are ready to be at your service!

If you find parts missing, broken, or hard to put together or when you are not satisfied or have any valuable suggestions, please do not hesitate to contact us first!

We will definitely give you a satisfactory solution or answer then!

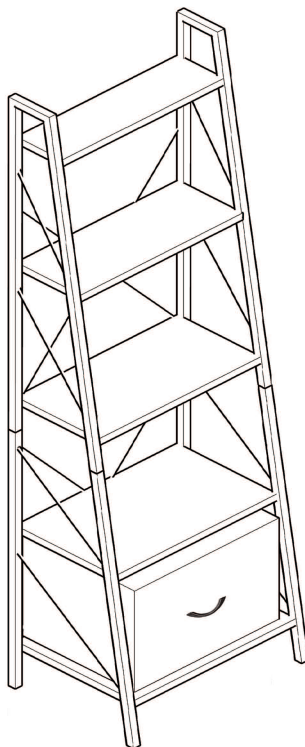

### Attention:

**\*\*\*** Some number parts listed on the instruction sheet may not be in parts bag as they may already be assembled.

Carefully check parts and packing materials prior to ordering replacements.







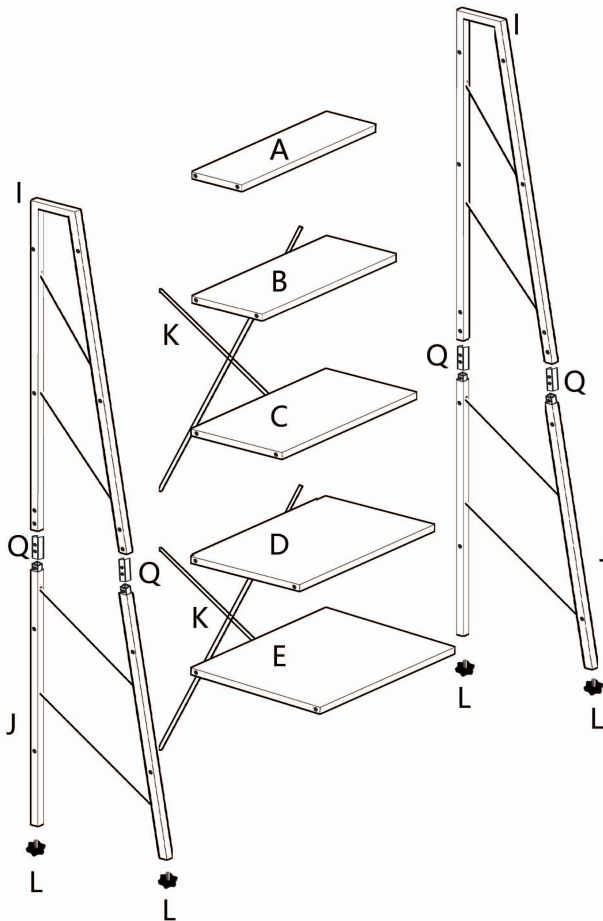







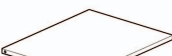

# General Assembly Guidelines

- I. Ensure that all parts and hardware are available before beginning assembly.
- II. Follow each step carefully to ensure the proper assembly of this product.
- III. Two people are recommended for ease in the assembly of this product.
- IV. The three main types of hardware used to assemble this product are: wood dowels, screws and bolts.

## COMPONENT PARTS



# COMPONENT PARTS

A		390*110*12mm	Artificial plate	1	pcs
B		390*155*12mm	Artificial plate	1	pcs
C		390*200*12mm	Artificial plate	1	pcs
D		390*240*12mm	Artificial plate	1	pcs
E		390*285*12mm	Artificial plate	1	pcs
G		φ5x40 mm	Long hexagon screws	21	pcs
H			M6*10mm screw	16	pcs
I			Above the iron frame	2	pcs
J			Below the iron frame	2	pcs
K			Back bracket strip	2	pcs
L			Leveling feet	4	pcs
M			Anti-falling device	1	pcs
O		3mm	hexagon spanner	1	pcs
P		4mm	hexagon spanner	1	pcs
Q			Connector	4	pcs
S			Drawer	1	pcs

# Step 1

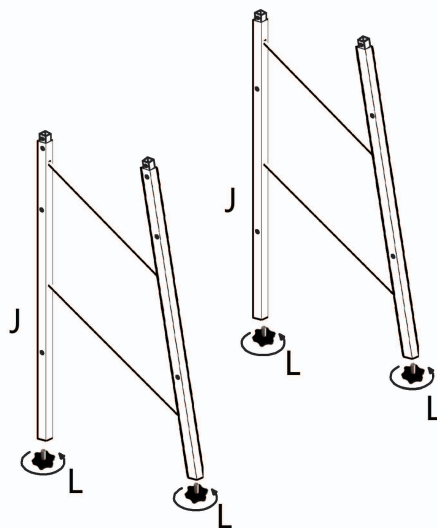
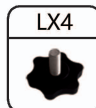
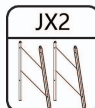

PAGE 1/6

# Step 2

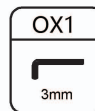
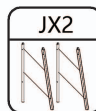
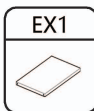
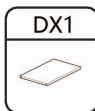

Note:

The rear bracket holes are on the same side

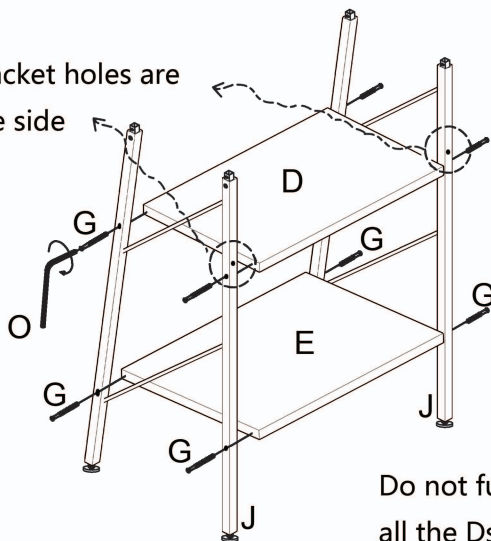

Do not fully tighten J to D till all the Ds attached to E

PAGE 4/8

# Step 3

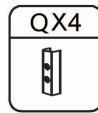
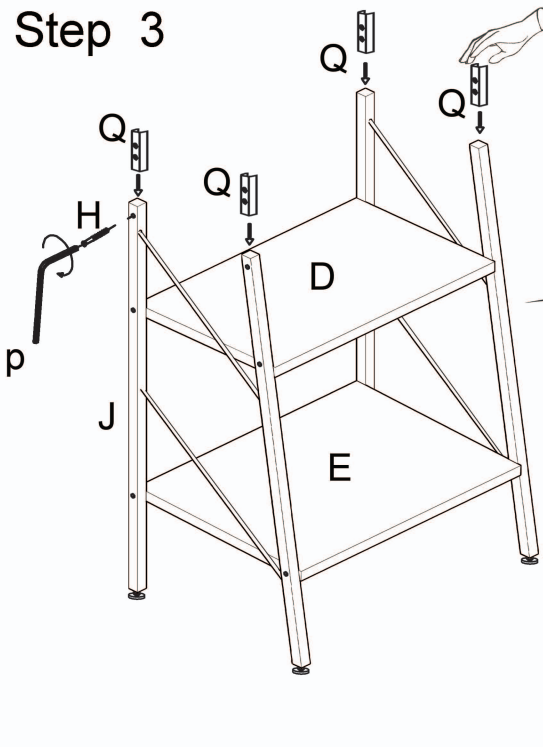

Note:  
Hold the connector when inserting it into part Q in case it falls into the hole of Q

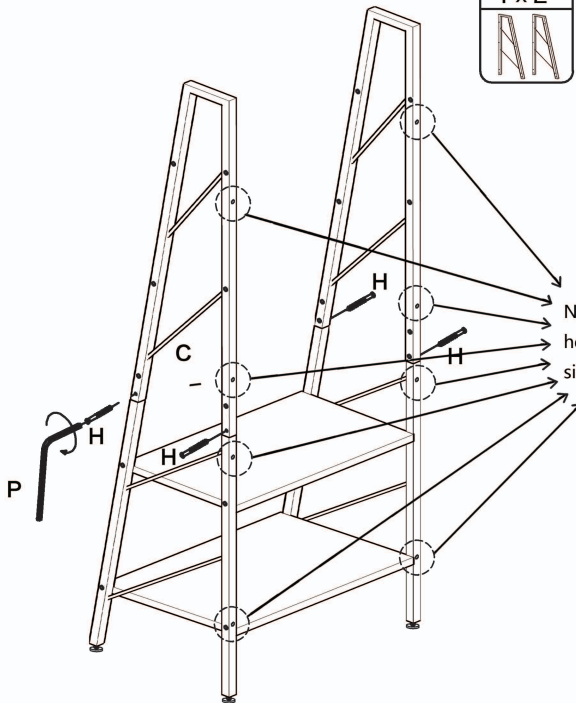
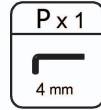
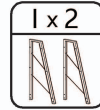
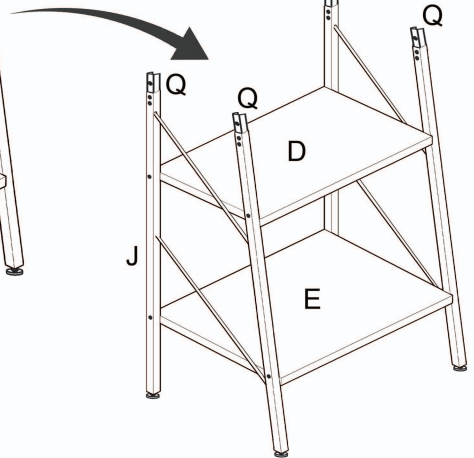

Note: The eight rear bracket holes are on the same side

# Step 4

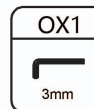
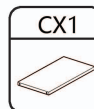
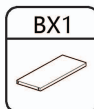
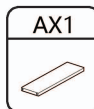

Fully tighten the frame to A B C  
after they are fixed in place

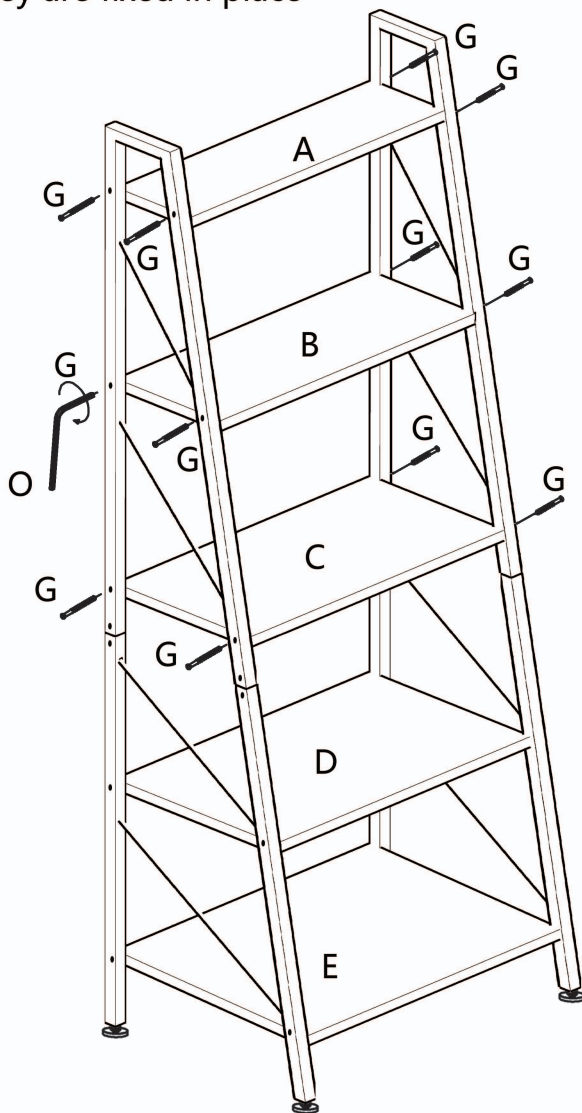

# Step 5

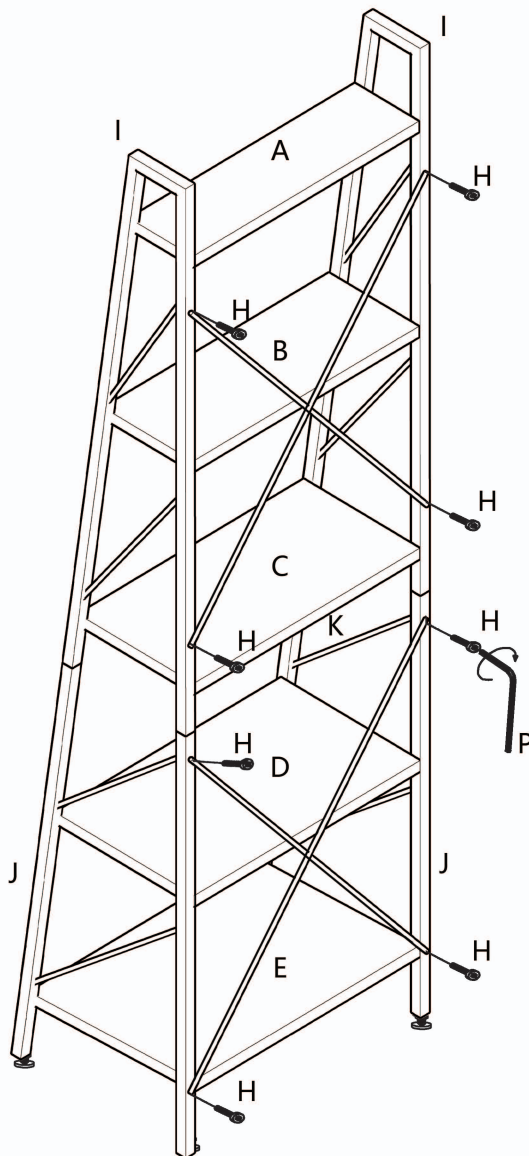
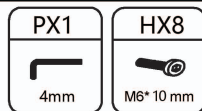

# Step 6

