

Installationsanleitung/Installation Instruction/Instruction d'installation  
Istruzioni di installazione/Instrucciones de instalación  
Installatie-instructies/Installationsanvisningar/Instrukcje instalacji  
BARTISCH-N620P430611/N620P430612  
BAR TABLE-N639P430642/N639P430643

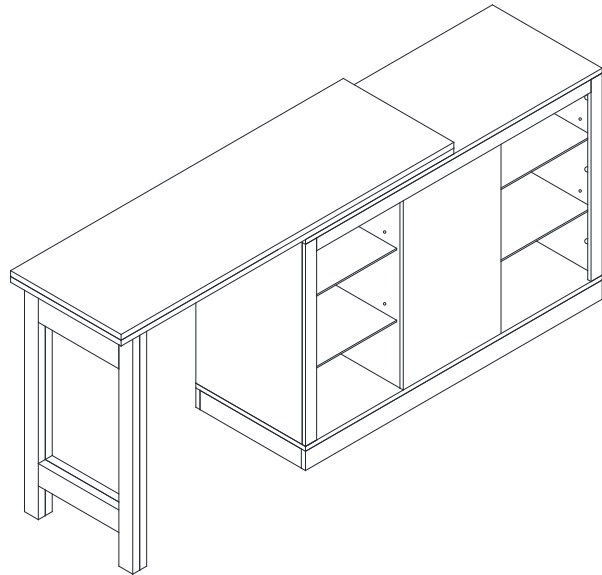
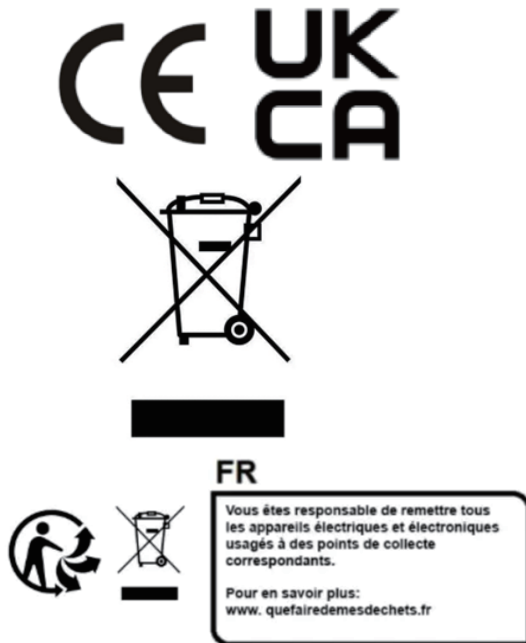

DE: Unser Produkt wird Ihnen in 2 Paketen geliefert. Die Lieferzeiten dieser 2 Pakete können abweichen, bitte haben Sie etwas Geduld und vielen Dank für Ihr Verständnis.

UK: Our product will be delivered to you in 2 packages. The delivery times of these 2 packages may differ, please be patient and thank you for your understanding.

FR: Notre produit vous sera livré en 2 colis. Les délais de livraison de ces 2 colis peuvent différer, soyez patient et merci pour votre compréhension.

IT: Il nostro prodotto verrà consegnato in 2 pacchi. I tempi di consegna di questi 2 pacchi possono variare; vi preghiamo di avere un po' di pazienza e vi ringraziamo per la vostra comprensione.

ES: Nuestro producto se entregará en 2 paquetes. Los tiempos de entrega de estos 2 paquetes pueden variar; por favor, tenga un poco de paciencia y gracias por su comprensión.

Installatie-instructies/Installationsanvisningar/Instrukcje instalacji

NL: Ons product wordt in 2 pakketten bij u geleverd. De levertijden van deze 2 pakketten kunnen verschillen, we vragen om uw geduld en bedanken u voor uw begrip.

SE: Vår produkt kommer att levereras till dig i 2 paket. Leveranstiderna för dessa 2 paket kan variera, vi ber om ditt tålamod och tackar för din förståelse.

PL: Nasz produkt zostanie dostarczony w 2 paczkach. Czas dostawy tych 2 paczek może się różnić, prosimy o cierpliwość i dziękujemy za zrozumienie.

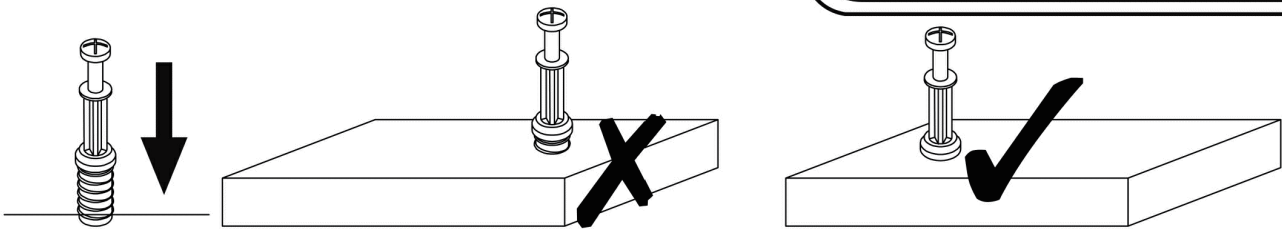

**EN\_ QUICKFIT:** Tighten quickfit until shoulder is flush with panel. Do not overtighten or undertighten.

**FR\_ RACCORD RAPIDE:** Faites serrer le raccord rapide jusqu'à ce que l'épaulement soit parfaitement encastré dans le panneau. Il ne faut ni trop serrer ni insuffisamment serrer.

**ES\_ QUICKFIT:** Apriete quickfit hasta que el hombro se descargue con el panel. NO lo sobreapriete ni lo apriete poco.

**DE\_ QUICKFIT:** Ziehen Sie den Quickfit fest, bis die Schulter mit der Platte bündig ist. Bitte nicht zu fest oder zu schwach anziehen.

**IT\_ MONTAGGIO RAPIDO:** Stringere il montaggio rapido fino a quando la spalla è a filo con il pannello, non stringere troppo o troppo poco.

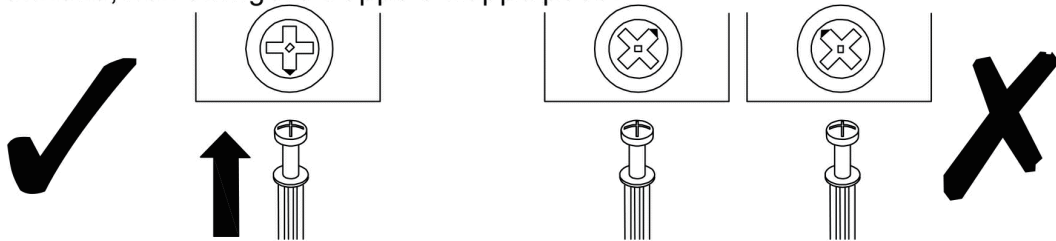

**EN\_ CAM LOCK:** When fitting cam lock, ensure starting position is correct before you insert connecting quickfit.

**FR\_ SERRURE BATTEUSE:** Avant d'insérer la serrure batteuse, veillez à la bonne orientation avant d'insérer le raccord rapide.

**ES\_ CIERRE DE LA CÁMARA:** Cuando instale el cierre de la cámara, asegúrese de que la posición de inicio es correcta antes de que inserte el quickfit conector.

**DE\_ CAM-LOCK:** Achten Sie bei der Montage des Cam-Locks auf die richtige Ausgangsposition, bevor Sie den Quickfit einsetzen.

**IT\_ BLOCCAGGIO A CAMMA:** Quando si monta il bloccaggio a camma, assicurarsi che la posizione iniziale sia corretta prima di inserire il montaggio rapido di collegamento.

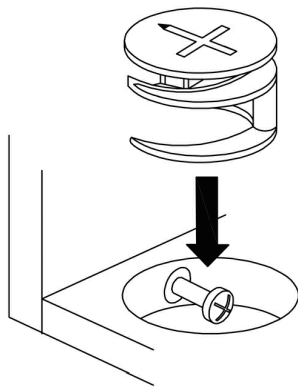

**EN\_ Quickfit head should be in the centre of the cam lock when the two panels are joined.**

Cam lock should be inserted before quickfit.

**FR\_ Lorsque les deux panneaux sont assemblés, la tête du raccord rapide doit reposer au centre de la serrure batteuse. Il faut insérer la serrure batteuse avant le raccord rapide.**

**ES\_ El cabezal del quickfit debe estar en el centro del cierre de la cámara cuando se unan los dos paneles.**

Se debe insertar el cierre de la cámara antes que el quickfit.

**DE\_ Der Quickfit-Kopf sollte sich in der Mitte des Cam-Locks befinden, wenn die beiden Platten zusammengefügt sind. Der Cam-Lock sollte vor dem Quickfit eingesetzt werden.**

**IT\_ La testa del montaggio rapido deve trovarsi al centro del bloccaggio a camma quando i due pannelli sono uniti.**

Il Bloccaggio a Camma deve essere inserito prima del montaggio rapido.

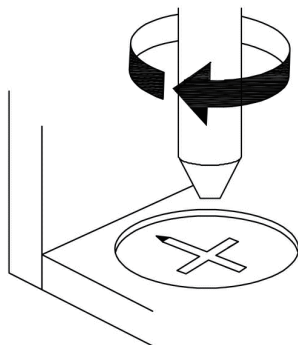

**EN\_ Turn cam lock clockwise to tighten.**

**FR\_ Faites tourner la serrure batteuse dans le sens des aiguilles d'une montre pour la resserrer.**

**ES\_ Gire el cierre de la cámara en sentido horario para apretarlo.**

**DE\_ Drehen Sie den Cam-Lock im Uhrzeigersinn, um ihn festzuziehen.**

**IT\_ Ruotare il bloccaggio a camma in senso orario per stringere.**

## DE

1. Die maximale Tragfähigkeit der Oberplatte beträgt 60 kg, bitte nicht überladen.
2. Lassen Sie Kinder nicht auf Möbeln klettern, da dies zu Umstürzen und schweren Verletzungen führen kann.
3. Um die Sicherheit zu gewährleisten, installieren Sie bitte gemäß der Anleitung und ziehen Sie bei Bedarf Fachleute hinzu.
4. Stellen Sie Möbel nicht in die Nähe von Feuerquellen oder heißen Gegenständen, um Brandgefahr zu vermeiden.
5. Stellen Sie Möbel nicht in feuchten Umgebungen auf, um Materialschäden zu verhindern.
6. Überprüfen Sie regelmäßig alle Verbindungs- und Befestigungselemente, um sicherzustellen, dass sie fest sitzen und Unfälle zu vermeiden.
7. Dieses Produkt ist mit einem Kipp-Schutz ausgestattet, installieren Sie diesen Schutz, um Verletzungen durch Umstürzen zu vermeiden.

## UK

1. The maximum weight capacity of the top panel is 60kg; please do not overload.
2. Do not allow children to climb on furniture, as this may cause tipping and serious injury.
3. To ensure safety, please install correctly according to the instructions and seek professional assistance if necessary.
4. Do not place furniture near fire sources or hot objects to avoid fire hazards.
5. Do not place furniture in damp environments to prevent material damage.
6. Regularly check all connectors and fasteners to ensure they are secure to prevent accidents.
7. This product comes with an anti-tipping device; install this device to prevent injuries from tipping.

## FR

1. La charge maximale du panneau supérieur est de 60 kg, ne pas surcharger.
2. Ne laissez pas les enfants grimper sur les meubles, cela peut entraîner des basculements et des blessures graves.
3. Pour garantir la sécurité, installez correctement selon les instructions et demandez l'aide de professionnels si nécessaire.
4. Ne placez pas les meubles près de sources de chaleur ou d'objets chauds pour éviter les risques d'incendie.
5. Ne placez pas les meubles dans des environnements humides pour éviter d'endommager les matériaux.
6. Vérifiez régulièrement tous les connecteurs et les fixations pour vous assurer qu'ils sont bien serrés et éviter les accidents.
7. Ce produit est équipé d'un dispositif anti-basculement; installez ce dispositif pour éviter les blessures dues au basculement.

## IT

1. La capacità massima del pannello superiore è di 60 kg; non sovraccaricare.
2. Non permettere ai bambini di arrampicarsi sui mobili, poiché ciò può causare ribaltamenti e gravi infortuni.
3. Per garantire la sicurezza, installare correttamente secondo le istruzioni e, se necessario, chiedere assistenza a professionisti.
4. Non posizionare i mobili vicino a fonti di calore o oggetti caldi per evitare rischi di incendio.
5. Non posizionare i mobili in ambienti umidi per prevenire danni ai materiali.
6. Controllare regolarmente tutti i connettori e le viti per assicurarsi che siano saldi e prevenire incidenti.
7. Questo prodotto è dotato di un dispositivo anti-ribaltamento; installare questo dispositivo per evitare infortuni da ribaltamento.

## ES

1. La capacidad máxima del panel superior es de 60 kg; no sobrecargar.
2. No permita que los niños escalen los muebles, ya que esto puede causar volcaduras y lesiones graves.
3. Para garantizar la seguridad, instale correctamente según las instrucciones y busque ayuda profesional si es necesario.
4. No coloque los muebles cerca de fuentes de fuego u objetos calientes para evitar riesgos de incendio.
5. No coloque los muebles en ambientes húmedos para evitar daños en los materiales.
6. Revise regularmente todos los conectores y sujetadores para asegurarse de que estén seguros y prevenir accidentes.
7. Este producto viene con un dispositivo anti-vuelco; instale este dispositivo para prevenir lesiones por vuelcos.

## NL

1. De maximale draagcapaciteit van het bovenpaneel is 60 kg; niet overbelasten.
2. Laat kinderen niet op meubels klimmen, dit kan leiden tot omvallen en ernstige verwondingen.
3. Installeer correct volgens de instructies om de veiligheid te waarborgen, en schakel indien nodig professionele hulp in.
4. Plaats meubels niet in de buurt van vuurbronnen of warme objecten om brandgevaar te voorkomen.
5. Plaats meubels niet in vochtige omgevingen om materiaalschade te voorkomen.
6. Controleer regelmatig alle verbindingen en bevestigingsmiddelen om ervoor te zorgen dat ze stevig zijn en om ongevallen te voorkomen.
7. Dit product is uitgerust met een kantelbeveiliging; installeer dit apparaat om verwondingen door omvallen te voorkomen.

## SE

1. Den maximala viktkapaciteten för överpanelen är 60 kg; överbelasta inte.
2. Låt inte barn klättra på möbler, då detta kan orsaka tippning och allvarliga skador.
3. För att säkerställa säkerheten, installera korrekt enligt instruktionerna och sök professionell hjälp om det behövs.
4. Placera inte möbler nära eldkällor eller heta föremål för att undvika brandrisk.
5. Placera inte möbler i fuktiga miljöer för att förhindra skador på materialen.
6. Kontrollera regelbundet alla kopplingar och fästelement för att säkerställa att de är säkra för att förhindra olyckor.
7. Denna produkt levereras med en anti-tippanordning; installera denna anordning för att förhindra skador vid tippning.

## PL

1. Maksymalne obciążenie górnej płyty wynosi 60 kg; nie przeciążaj.
2. Nie pozwól dzieciom wspinać się na meble, ponieważ może to prowadzić do przewrócenia się i poważnych obrażeń.
3. Aby zapewnić bezpieczeństwo, zainstaluj prawidłowo zgodnie z instrukcją i w razie potrzeby skorzystaj z pomocy profesjonalistów.
4. Nie stawiaj mebli w pobliżu źródeł ognia lub gorących przedmiotów, aby uniknąć ryzyka pożaru.
5. Nie stawiaj mebli w wilgotnych środowiskach, aby zapobiec uszkodzeniu materiałów.
6. Regularnie sprawdzaj wszystkie złącza i elementy mocujące, aby upewnić się, że są stabilne i aby zapobiec wypadkom.
7. Produkt ten jest wyposażony w urządzenie zapobiegające przewróceniu; zainstaluj to urządzenie, aby uniknąć obrażeń w wyniku przewrócenia.

## •Components - fittings

Please check you have all the panels listed below.

Note: The quantities below are the correct amount to complete the assembly. In some cases more fittings may be supplied than are required.

## •Komponenten Verschraubungen

Bitte überprüfen Sie, ob Sie alle unten aufgeführten Panels haben.

Hinweis: Die folgende Menge ist die richtige Menge, um die Montage abzuschließen. In einigen Fällen

können mehr Armaturen geliefert werden, als erforderlich.

## •Composants - accessoires





Veuillez vérifier que vous possédez tous les panneaux énumérés ci - dessous.

Remarque: les quantités ci - dessous sont les quantités correspondantes nécessaires pour terminer



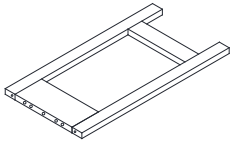
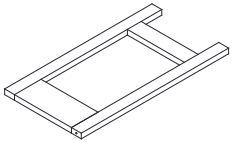
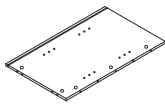
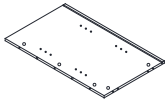
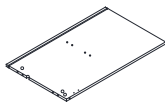
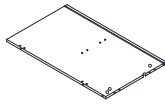

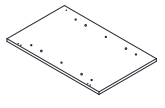
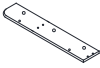
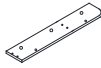
l'assemblage. Dans certains cas, plus d'accessoires que nécessaire peuvent être fournis.

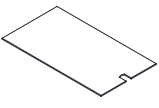
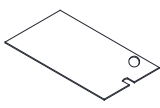
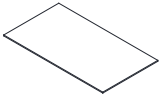
**N620P430611- Box:1/2**

**N639P430642- Box:1/2**

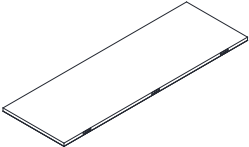
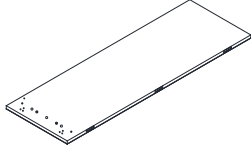
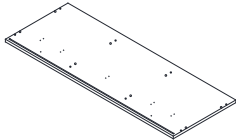
 ③ X1	 ④ X1	 ⑥ X1
 ⑦ X1	 ⑧ X1	 ⑨ X1
 ⑬ X4	 ⑭ X1	 ⑱ X1
 ⑲ X1	 ⑳ X1	 ㉑ X2
 ㉒ X2	 ㉓ X1	 ㉔ X1
 ㉕ X1		

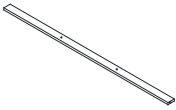
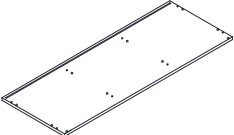
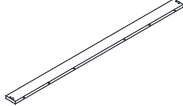
**N620P430612- Box:2/2**  
**N639P430643- Box:2/2**

 <p>①X1</p>	 <p>②X1</p>	 <p>⑤X1</p>
 <p>⑩X1</p>	 <p>⑪X1</p>	 <p>⑫X1</p>
 <p>⑮X1</p>	 <p>⑯X2</p>	 <p>⑰X2</p>

## •Components - fittings

Please check you have all the panels listed below.

Note: The quantitie below are the correct amount to complete the assembly. In some cases more fittings may be supplied than are required.

## •Komponenten Verschraubungen

Bitte überprüfen Sie, ob Sie alle unten aufgeführten Panels haben.

Hinweis: Die folgende Menge ist die richtige Menge, um die Montage abzuschließen. In einigen Fällen

können mehr Armaturen geliefert werden, als erforderlich.

## •Composants - accessoires











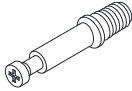

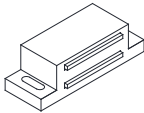
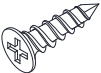
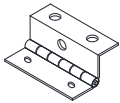
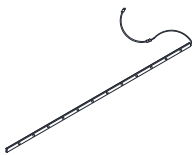
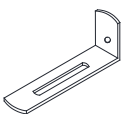
Veuillez vérifier que vous possédez tous les panneaux énumérés ci - dessous.

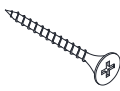
Remarque: les quantités ci - dessous sont les quantités correspondantes nécessaires pour terminer

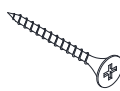
l'assemblage. Dans certains cas, plus d'accessoires que nécessaire peuvent être fournis.

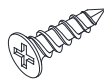
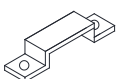
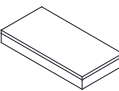
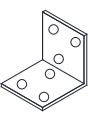
**N620P430611- Box:1**

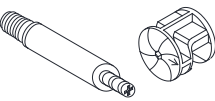
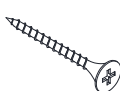
**N620P430612- Box:1**

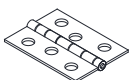
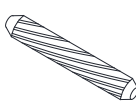
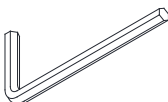
				
6*35mm	15*10mm	6*30mm		3*10mm
Ax40PCS	Bx40PCS	Cx40PCS	Dx1PC	Ex21PCS
				
Fx2PCS	Gx1PC	Hx2PCS	lx2PCS	Jx8PCS
				
Kx2PCS	Lx14PCS	Mx12PCS	Nx38PCS	Ox5PCS
				
Px6PCS	Qx2PCS	Rx1PC	Sx16PCS	Tx2PCS
				
3*25mm	Vx3PCS	Wx2PCS	Xx3PCS	Yx1PC
Ux12PCS				

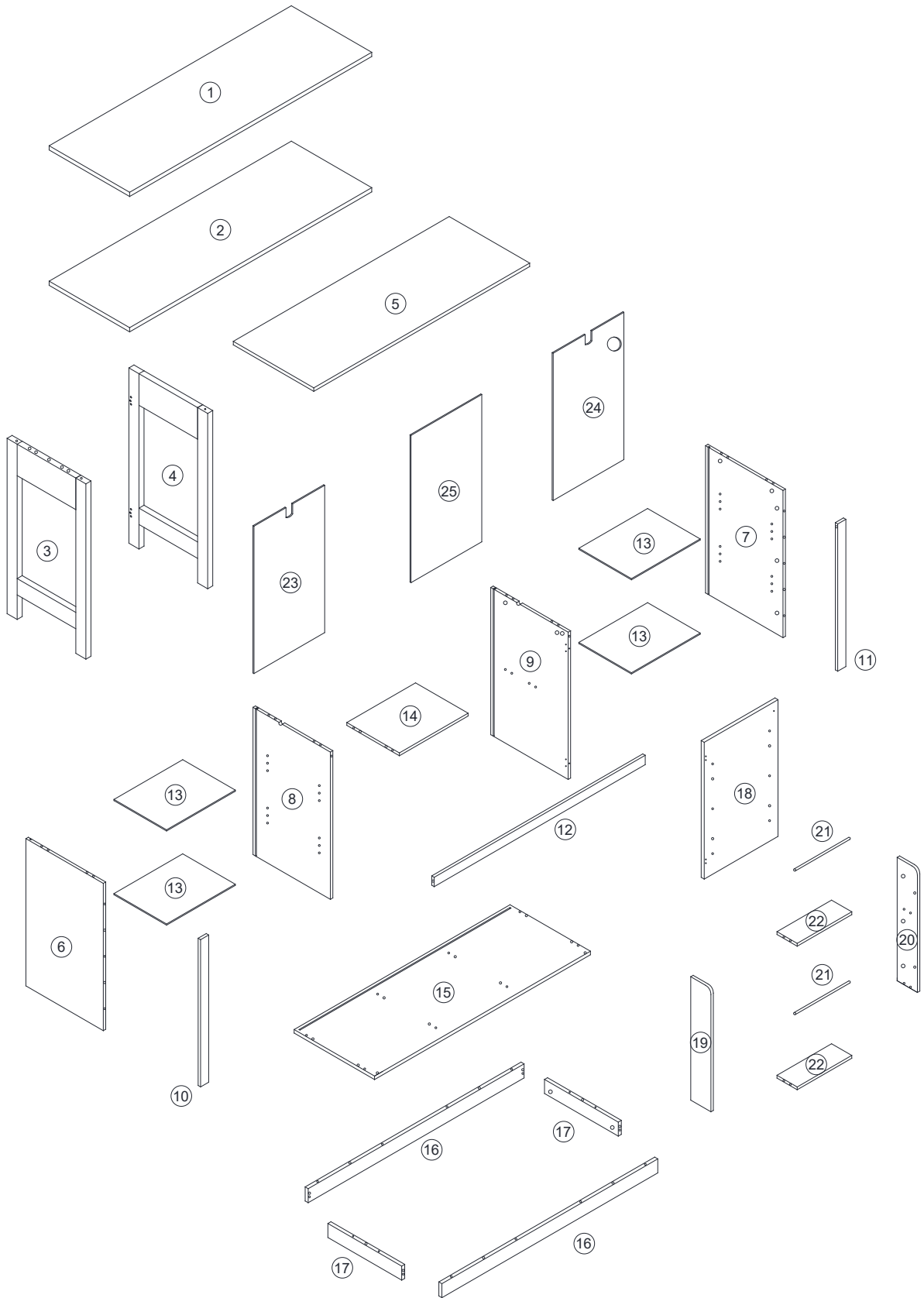





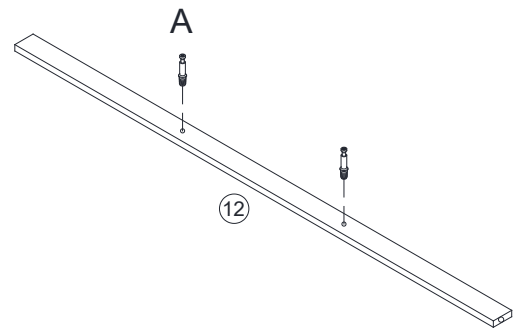
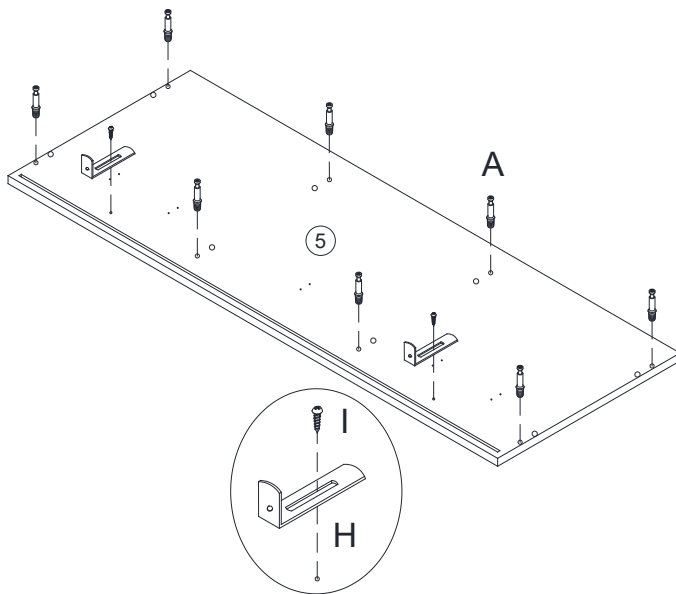
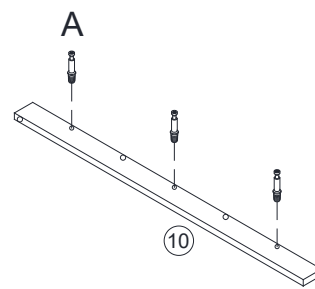
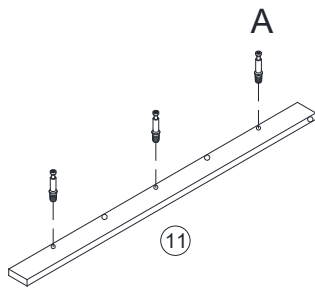
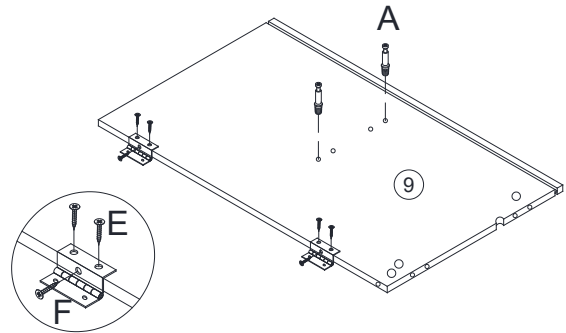
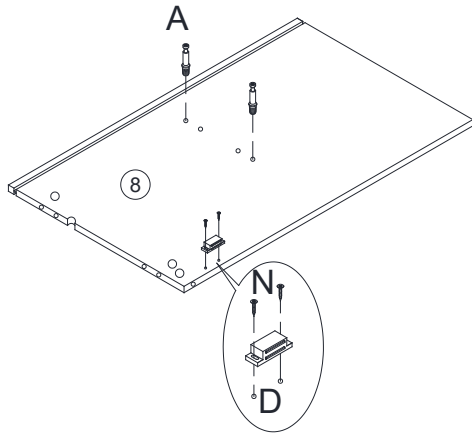

Importeur	Decobus Handel GmbH
Adresse	Innungsstraße 9, 21244 Buchholz, Deutschland
URL	<a href="https://www.decobusgroup.de">https://www.decobusgroup.de</a>
Hersteller	Ningde Yibang Furniture Co., Ltd
Adresse	No. 1, Industrial Zone, Gantang Village, Gantang Township, Pingnan County, Ningde City, Fujian, China.
Email/URL	yvonne@yibang-fur.com
Partienummer	N620P430611/N620P430612
Hergestellt in	CHINA
EC REP	Decobus Handel GmbH Innungsstraße 9, 21244 Buchholz, Deutschland <a href="https://www.decobusgroup.de">https://www.decobusgroup.de</a>

Importer	COMHARBOR LIMITED
Add	Unit C, Swift Point, Cosford Lane, Rugby, CV21 1PY, GB
Email/URL	harborcomhar@gmail.com
Manufacturer	Ningde Yibang Furniture Co., Ltd
Add	No. 1, Industrial Zone, Gantang Village, Gantang Township, Pingnan County, Ningde City, Fujian, China.
Email/URL	yvonne@yibang-fur.com
Product identification	N639P430642/N639P430643
Made in	CHINA
UK REP	COMHARBOR LIMITED Unit C, Swift Point, Cosford Lane, Rugby, CV21 1PY, GB harborcomhar@gmail.com



# STEP 1/SCHRITT 1/étapes 1/Passo 1/Paso 1



						
A x 20pcs	D x 1pc	E x 6pcs	F x 2pcs	H x 2pcs	I x 2pcs	N x 2pcs

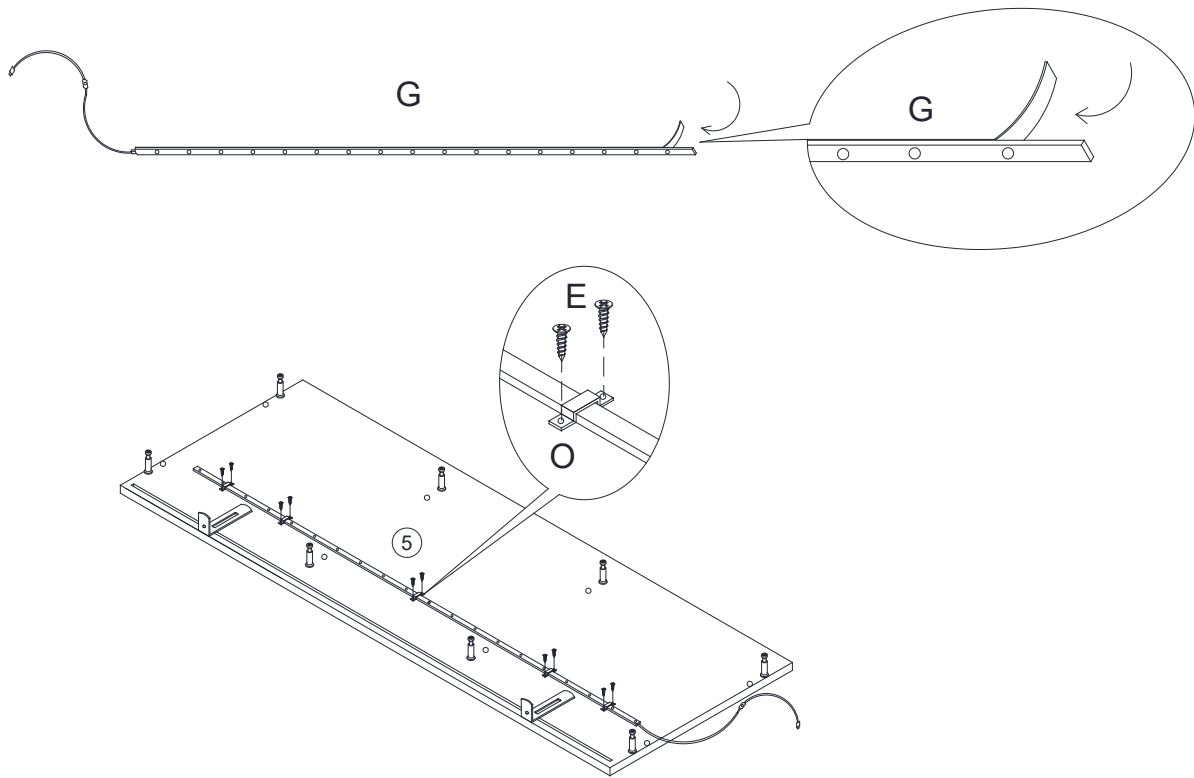

## STEP 2/SCHRITT 2/étapes 2/Passo 2/Paso 2



		
E x 10pcs	G x 1pc	O x 5pcs

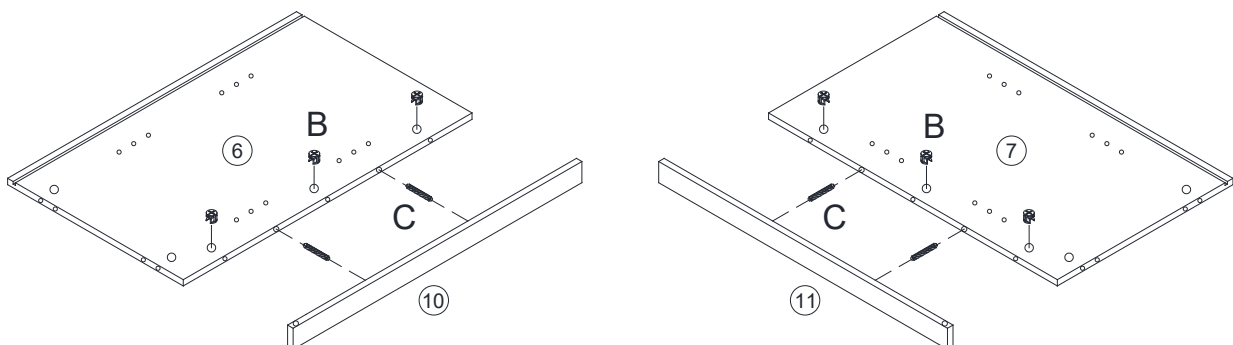

## STEP 3/SCHRITT 3/étapes 3/Passo 3/Paso 3

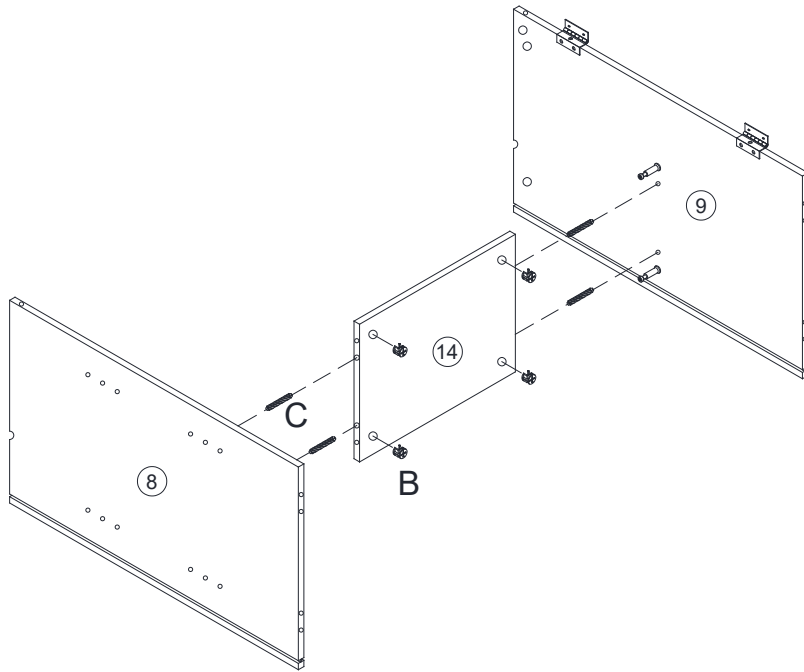

	
B x 6pcs	C x 4pcs

## STEP 4/SCHRITT 4/étapes 4/Passo 4/Paso 4



	
B x 4pcs	C x 4pcs

## STEP 5/SCHRITT 5/étapes 5/Passo 5/Paso 5

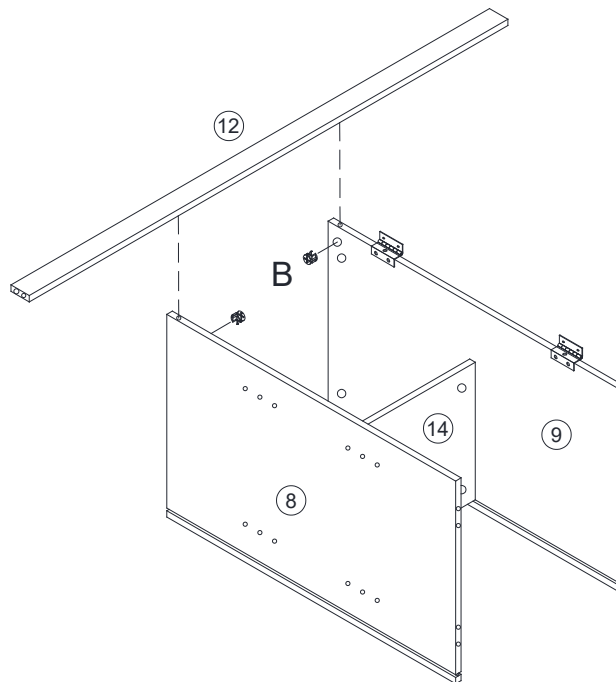

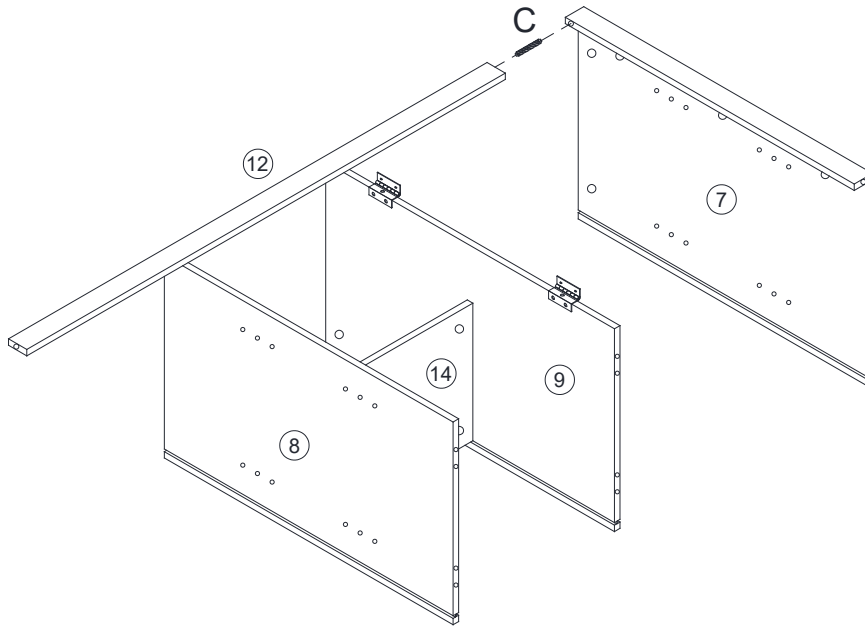

B x 2pcs

## STEP 6/SCHRITT 6/étapes 6/Passo 6/Paso 6



C x 1pc

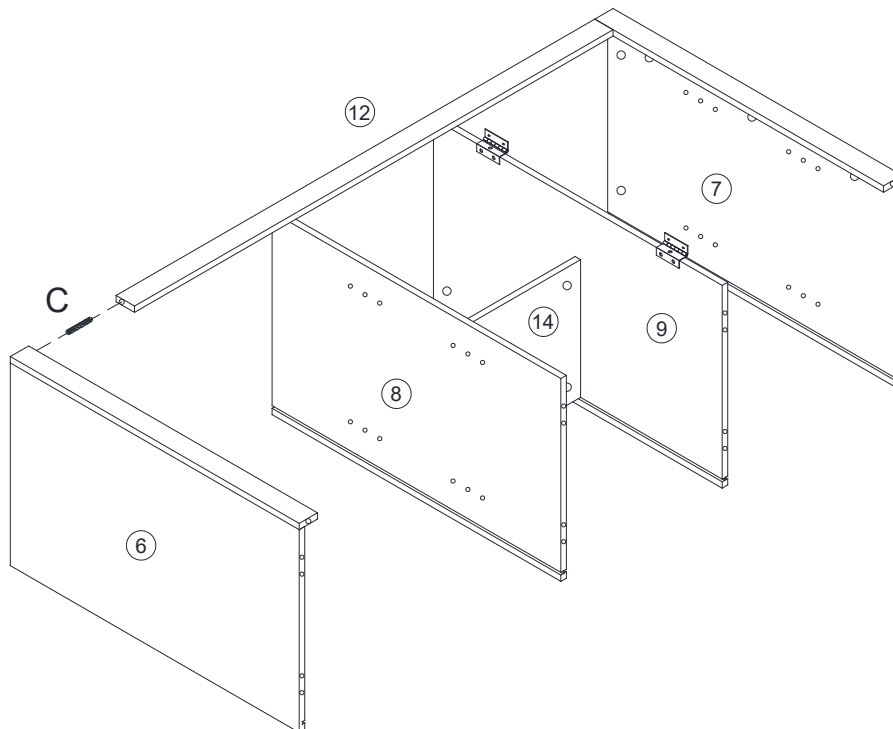

## STEP 7/SCHRITT 7/étapes 7/Passo 7/Paso 7

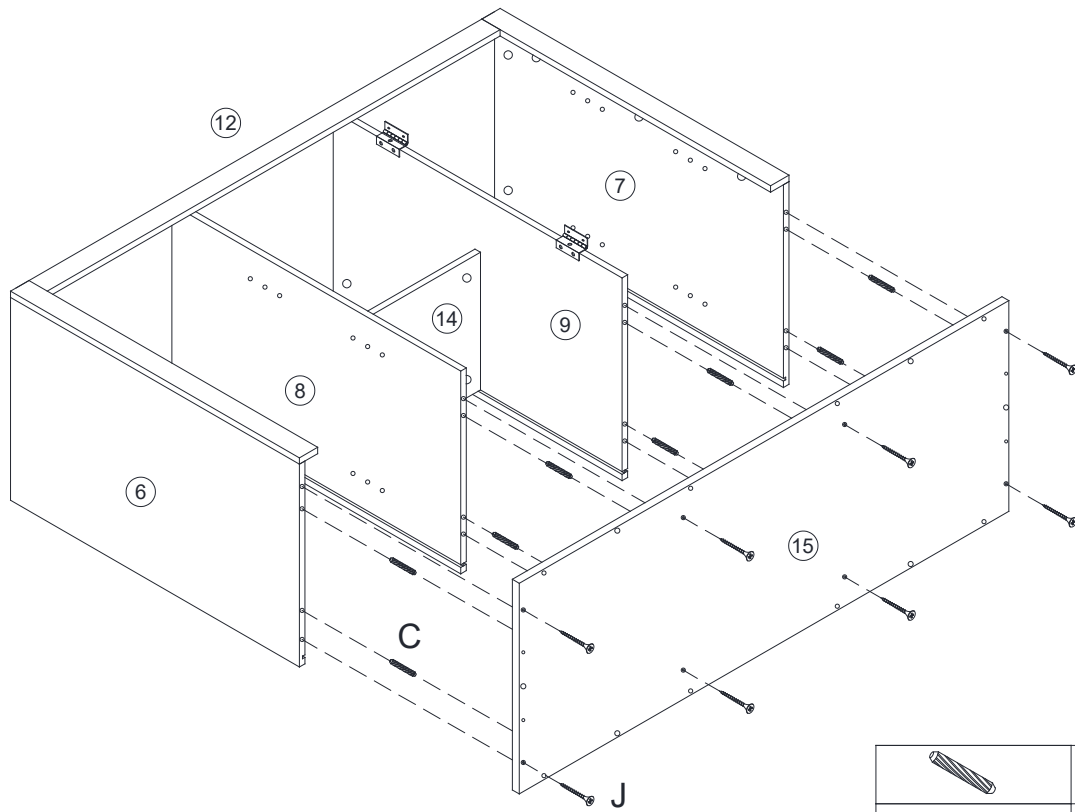

C x 1pc

## STEP 8/SCHRITT 8/étapes 8/Passo 8/Paso 8



	
C x 8pcs	J x 8pcs

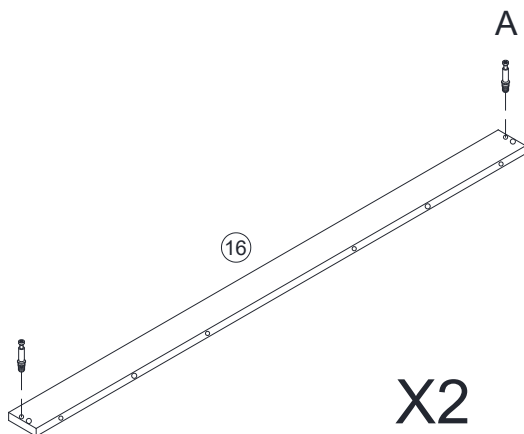

## STEP 9/SCHRITT 9/ étapes 9/Passo 9/Paso 9



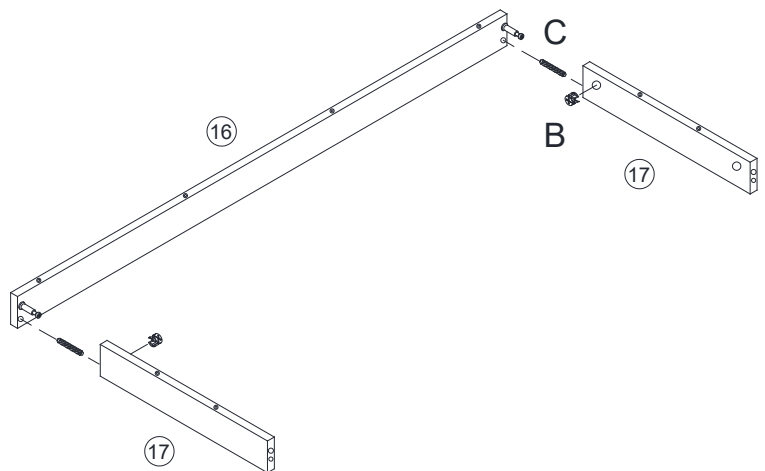

A x 4pcs



## STEP 10/SCHRITT 10/ étapes 10/Passo 10/Paso 10

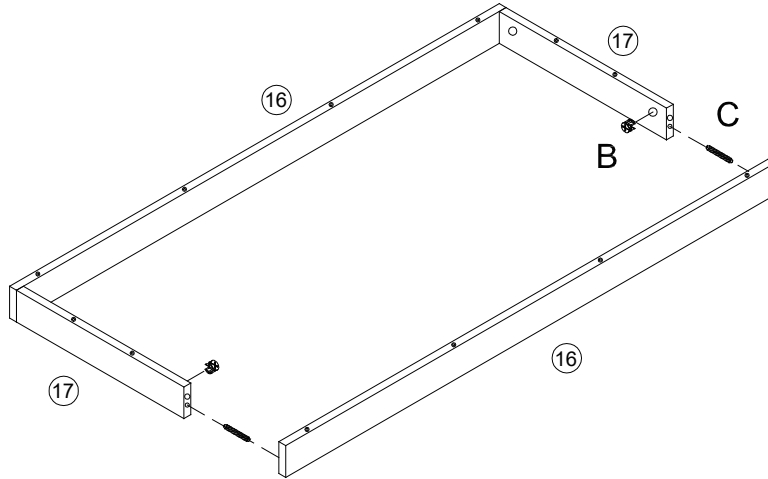

	
B x 2pcs	C x 2pcs

## STEP 11/SCHRITT 11/étapes 11/Passo 11Paso 11



	
B x 2pcs	C x 2pcs

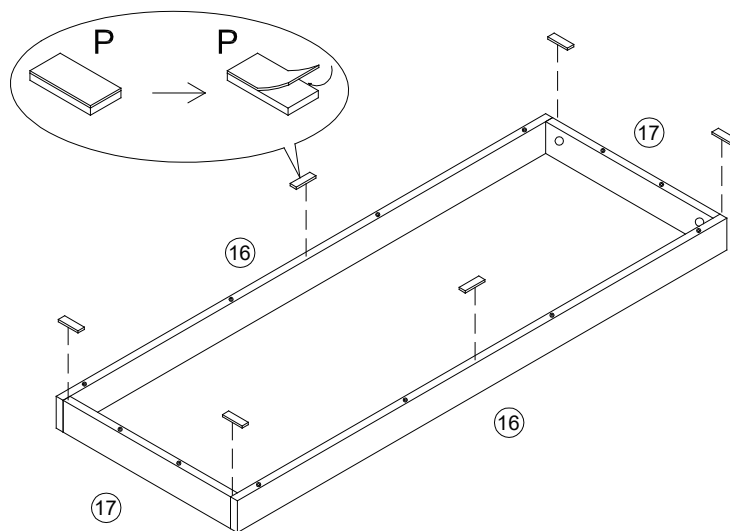

## STEP 12/SCHRITT 12/étapes 12/Passo 12Paso 12



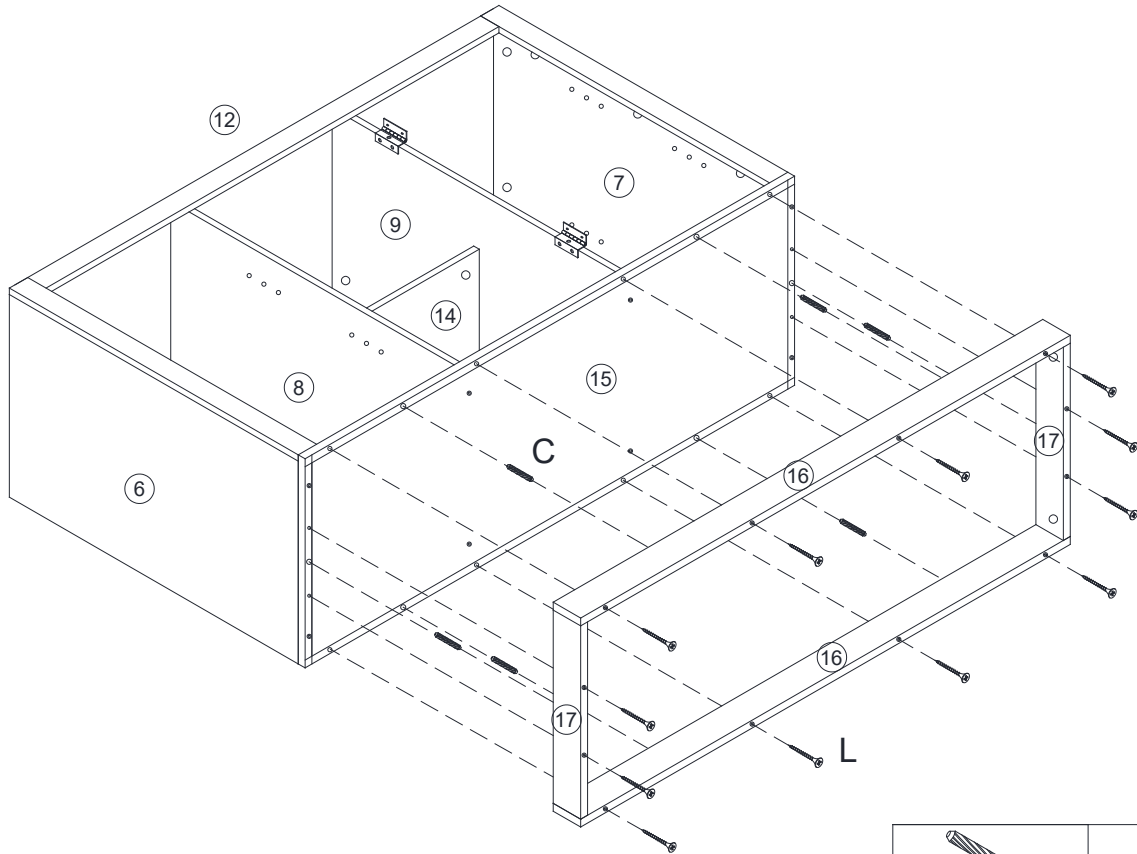

P x 6pcs

### STEP 13/SCHRITT 13/étapes 13/Passo 13/Paso 13



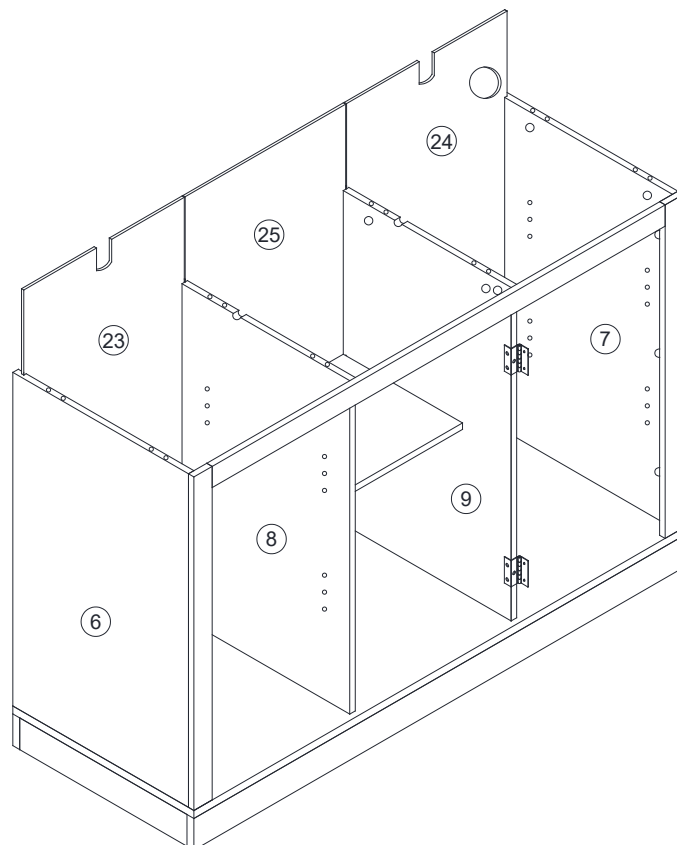

	
C x 6pcs	L x 12pcs

### STEP 14/SCHRITT 14/étapes 14/Passo 14/Paso 14



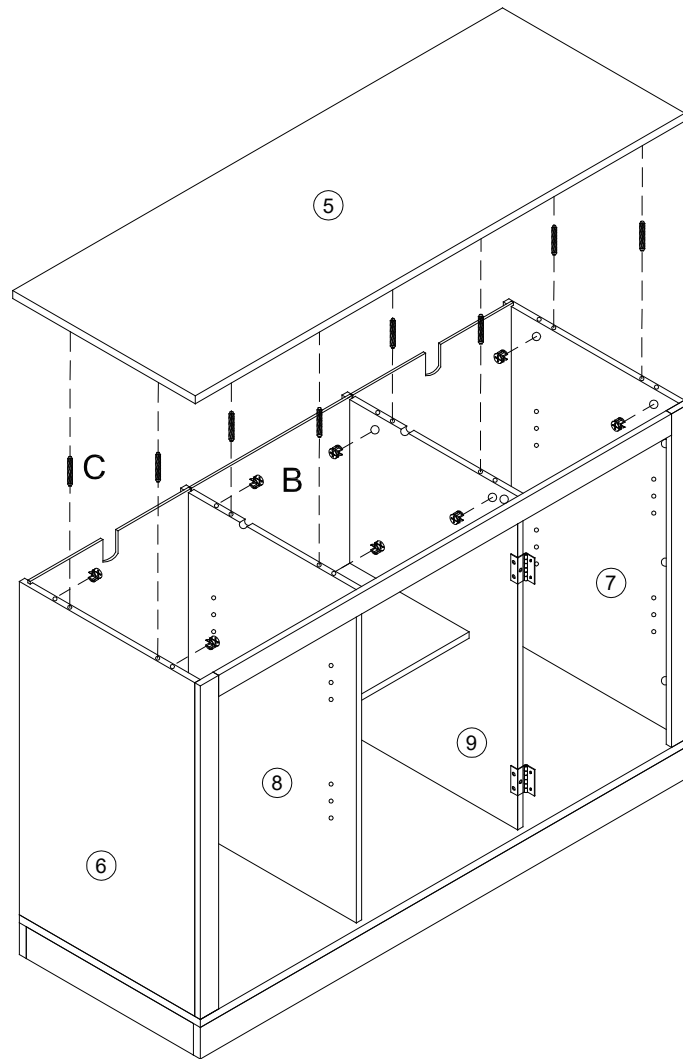

## STEP 15/SCHRITT 15/étapes 15/Passo 15/Paso 15



	
B x 8pcs	C x 8pcs

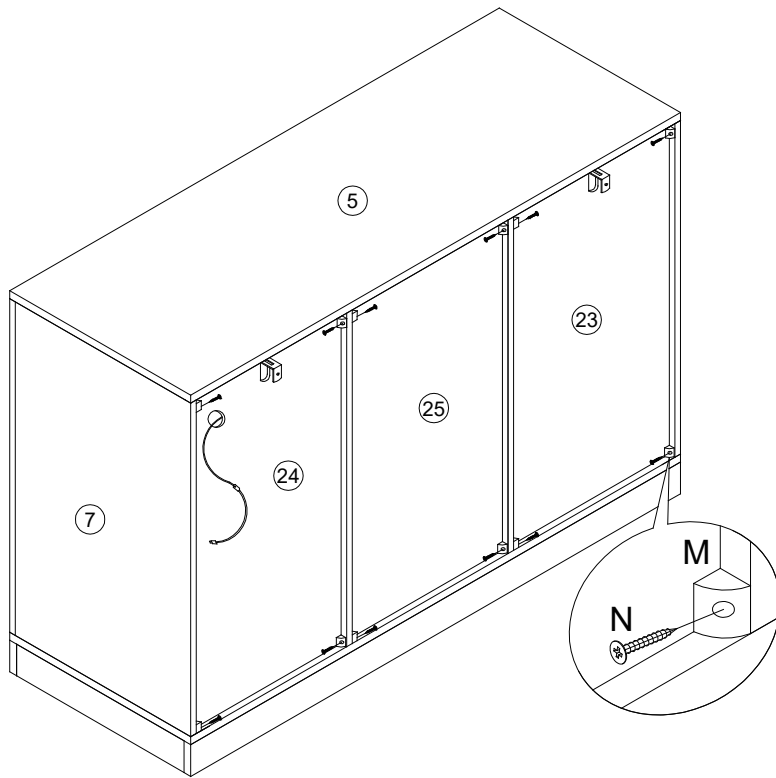

## STEP 16/SCHRITT 16/étapes 16/Passo 16/Paso 16



	
M x 12pcs	N x 12pcs

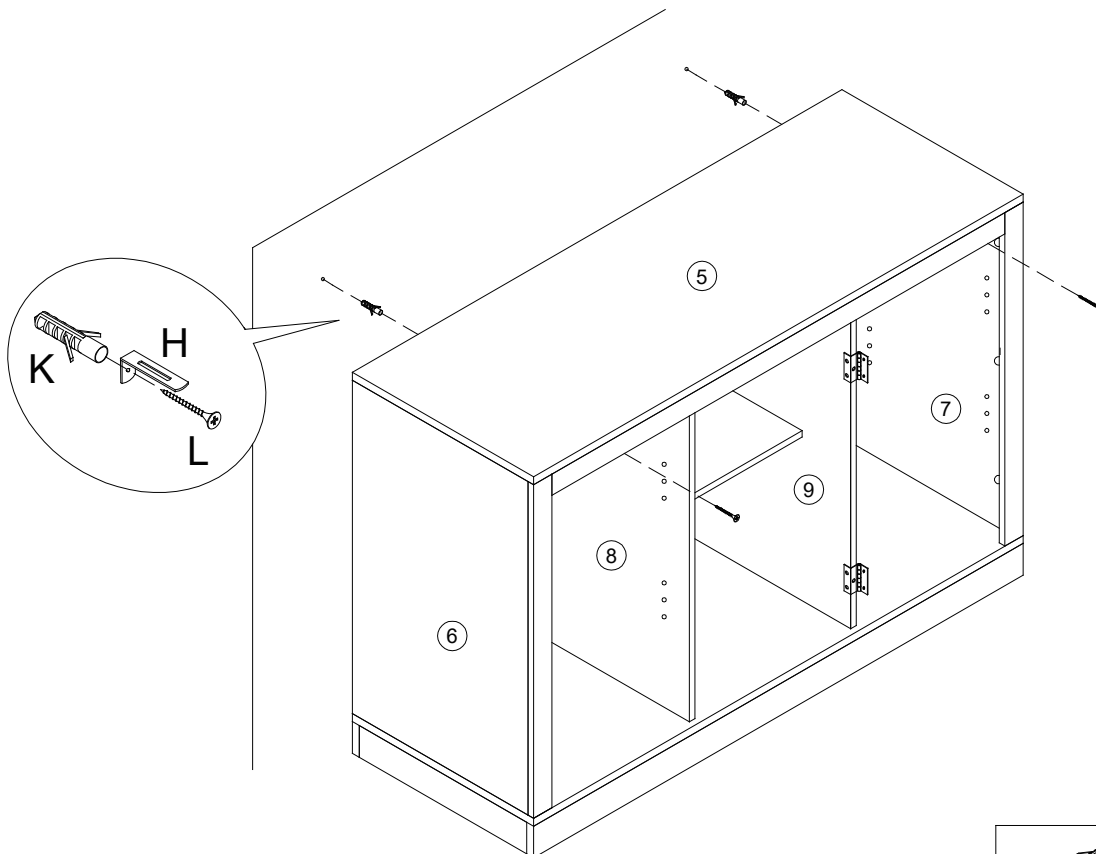

## STEP 17/SCHRITT 17/étapes 17/Passo 17/Paso 17

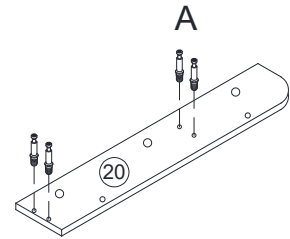
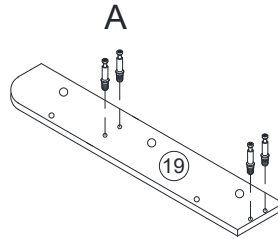
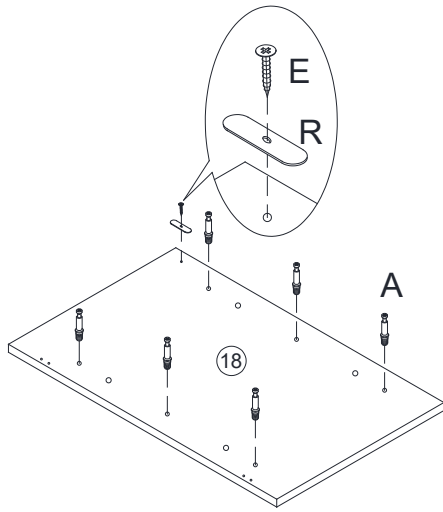

	
K x 2pcs	L x 2pcs

## STEP 18/SCHRITT 18/étapes 18/Passo 18/Paso 18



		
A x 14pcs	E x 1pc	R x 1pc

## STEP 19/SCHRITT 19/ étapes 19/Passo 19/Paso 19

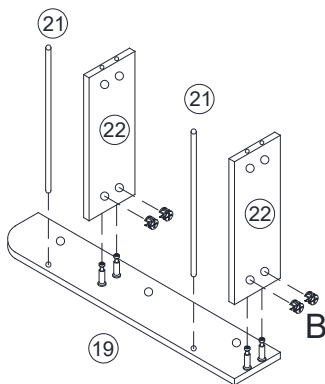



B x 4pcs

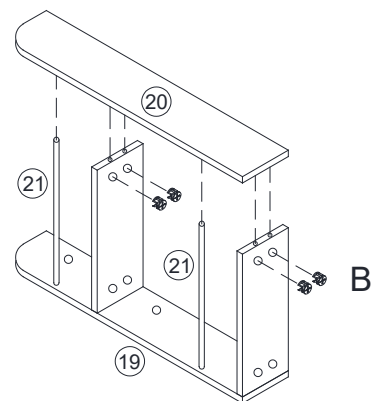

## STEP 20/SCHRITT 20/ étapes 20/Passo 20/Paso 20



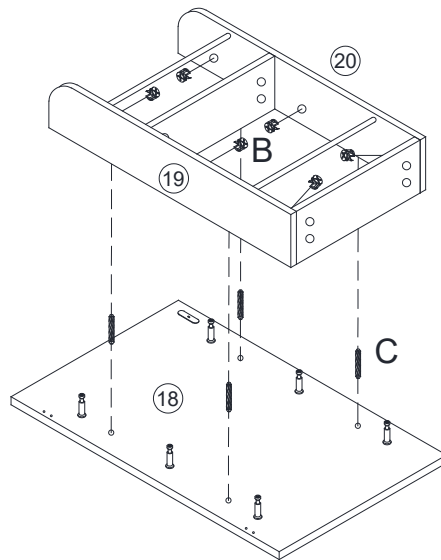

B x 4pcs

## STEP 21/SCHRITT 21/étapes 21/Passo 21/Paso 21

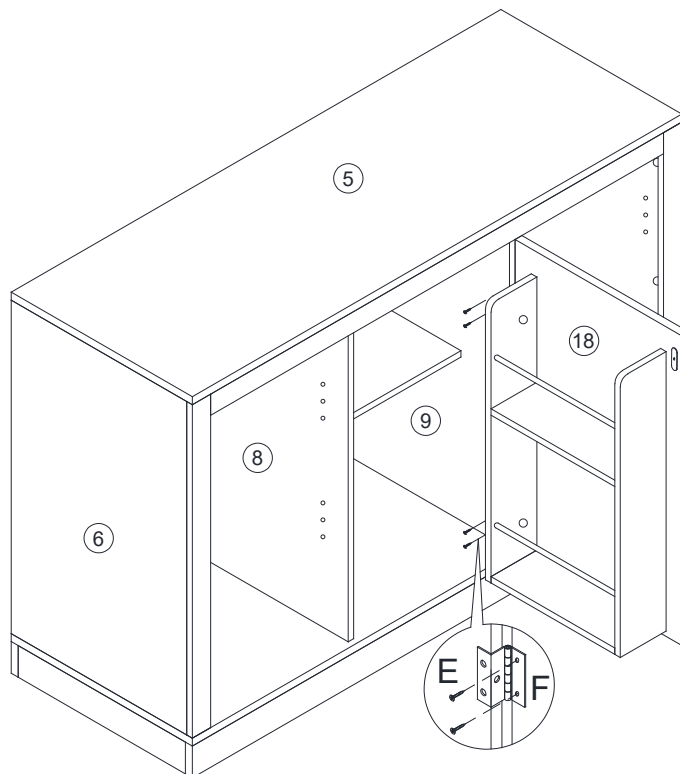

	
B x 6pcs	C x 4pcs

## STEP 22/SCHRITT 22/étapes 22/Passo 22/Paso 22





E x 4pcs

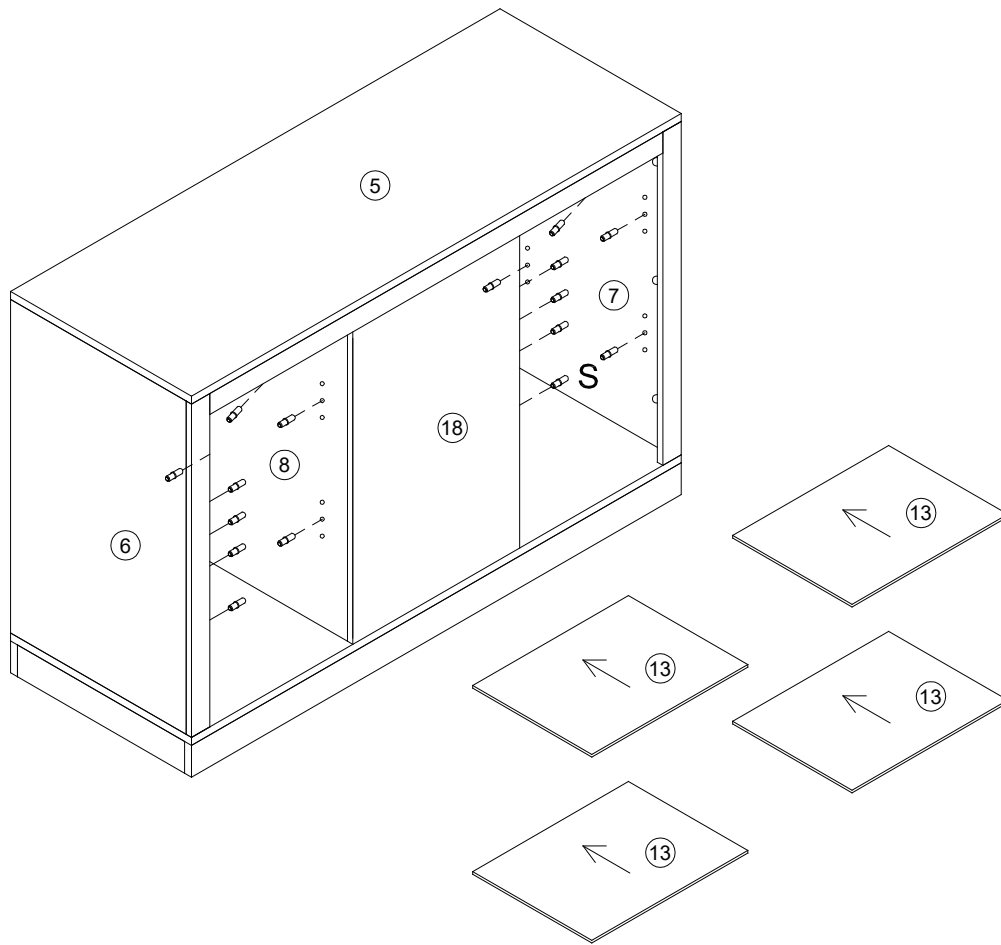

## STEP 23/SCHRITT 23/étapes 23/Passo 23/Paso 23



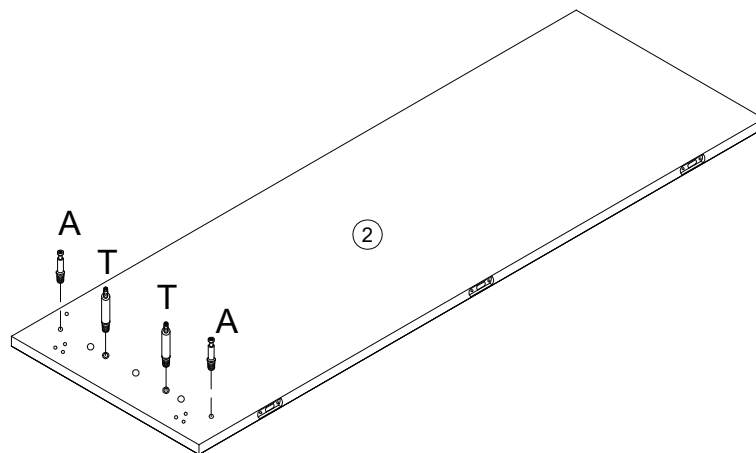

S x 16pcs



## STEP 24/SCHRITT 24/étapes 24/Passo 24/Paso 24

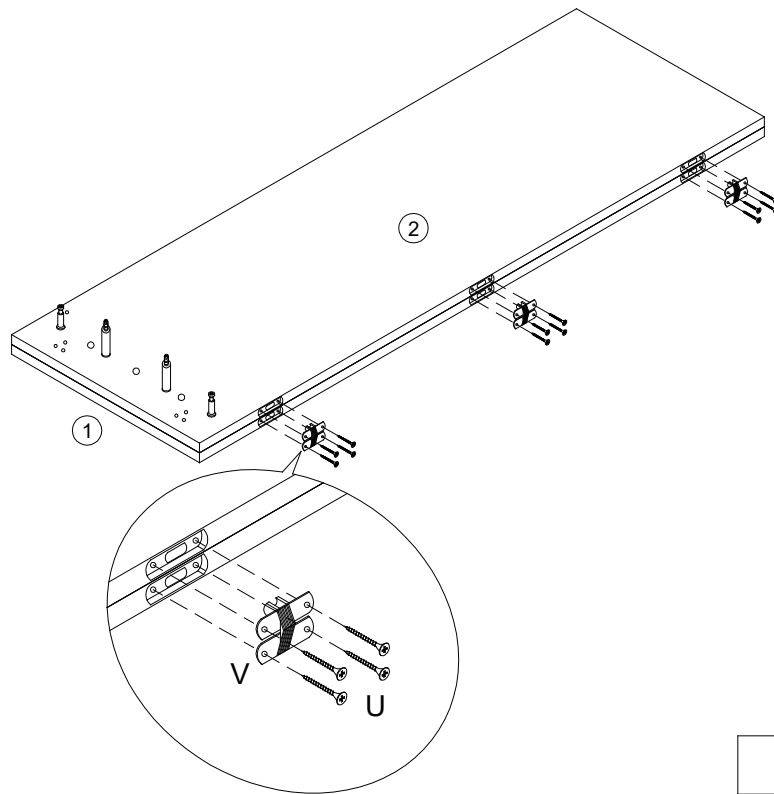

	
A x 2pcs	T x 2pcs

## STEP 25/SCHRITT 25/étapes 25/Passo 25/Paso 25



	
U x 12pcs	V x 3pcs

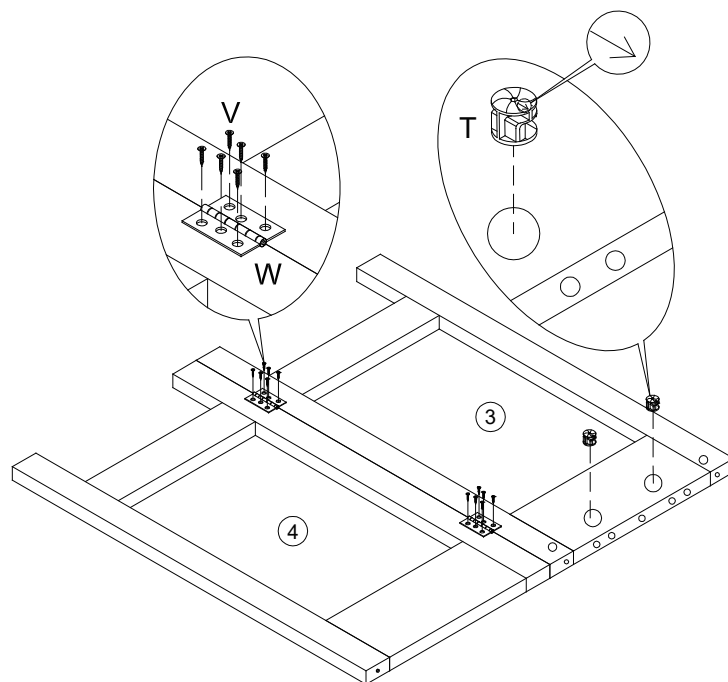

## STEP 26/SCHRITT 26/étapes 26/Passo 26/Paso 26



		
N x 12pcs	T x 2pcs	W x 2pcs

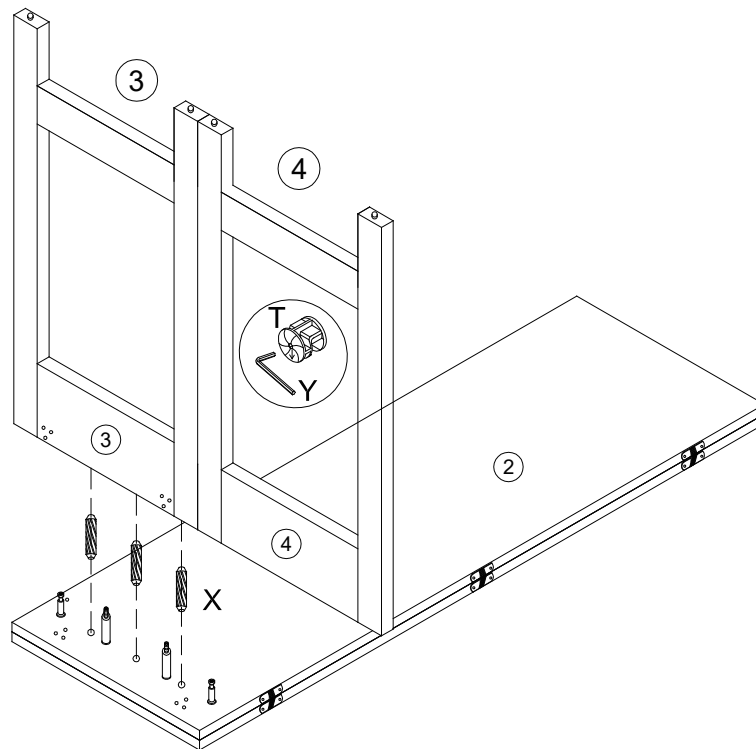

## STEP 27/SCHRITT 27/étapes 27/Passo 27/Paso 27

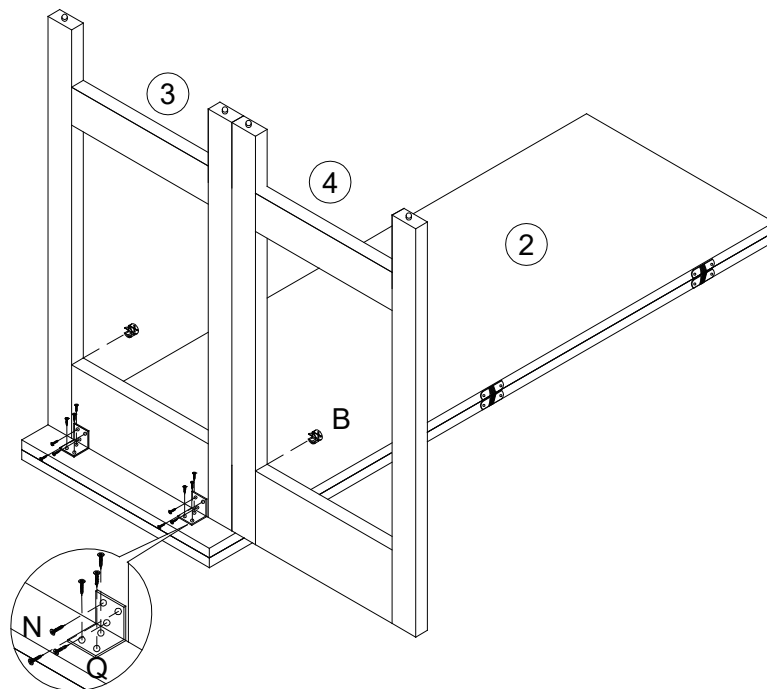

	
X x 3pcs	Y x 1pc

## STEP 28/SCHRITT 28/étapes 28/Passo 28/Paso 28



		
B x 2pcs	Q x 2pcs	N x 12pcs

## STEP 29/SCHRITT 29/étapes 29/Passo 29/Paso 29

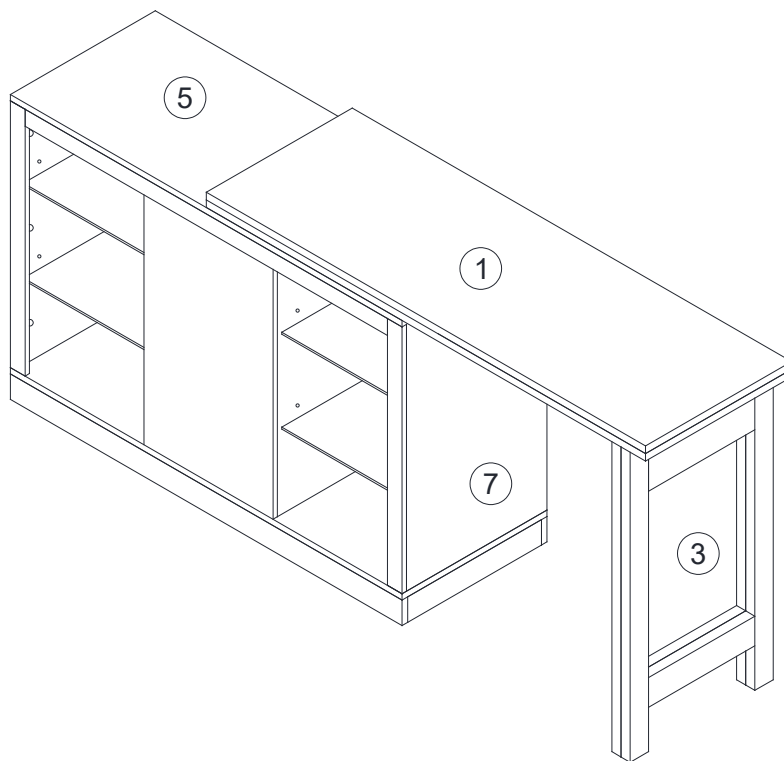
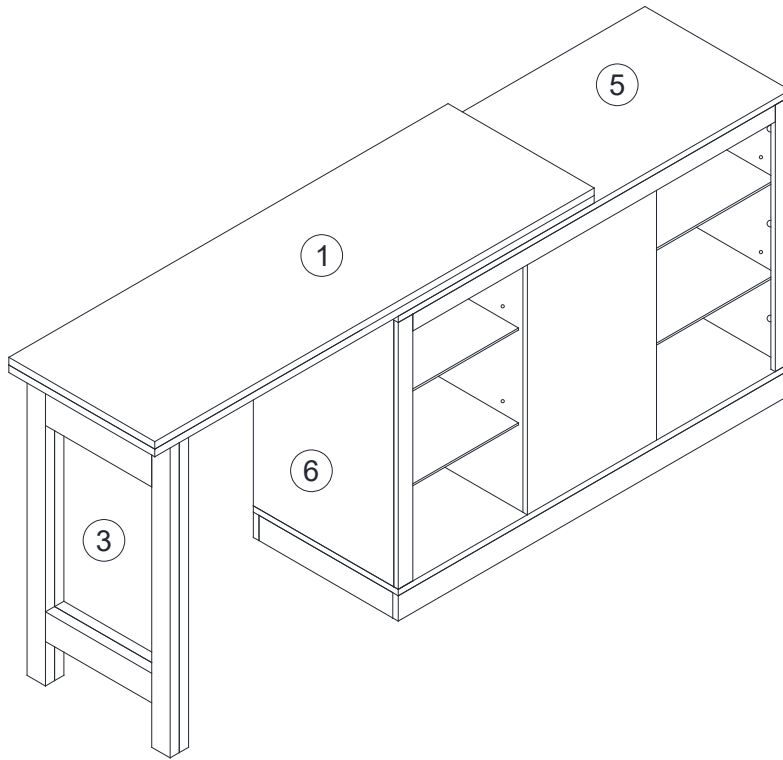

## STEP 30/SCHRITT 30/étapes 30/Passo 30/Paso 30

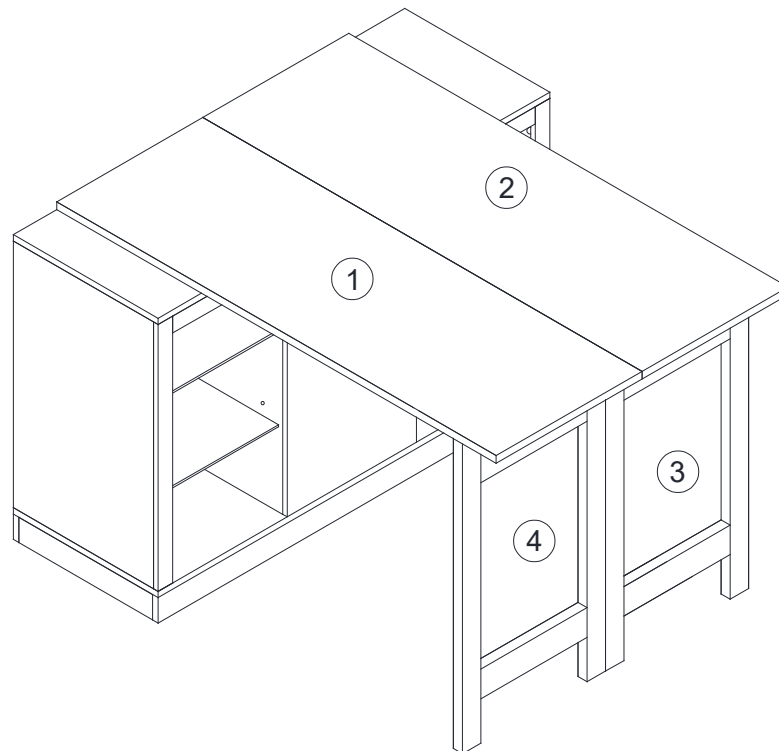
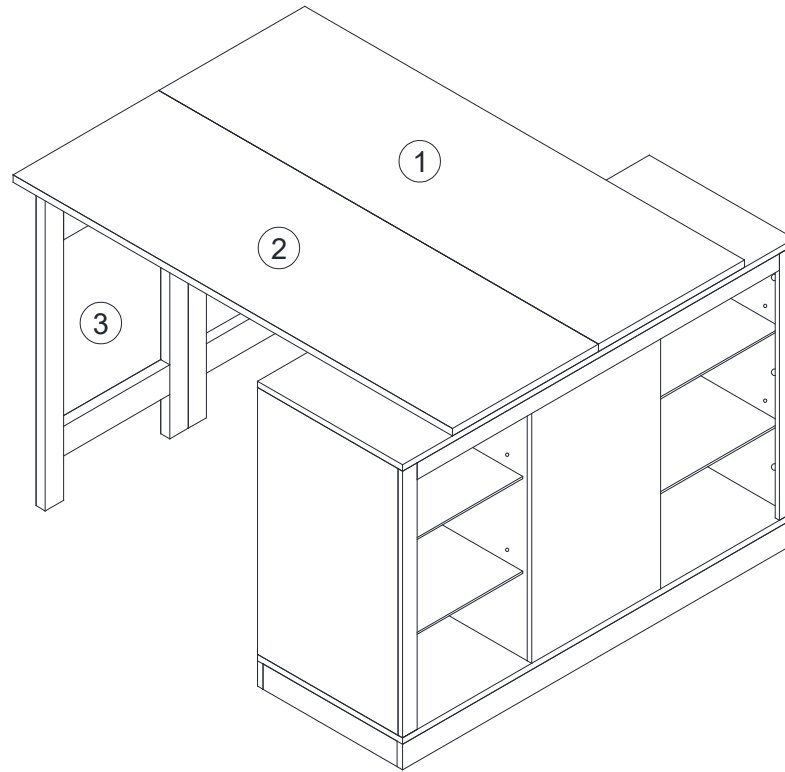

DE:Vor dem Einbau die Schrauben in die Löcher stecken und festziehen, aber nicht bis 100%, 70% bis 80% anziehen reicht aus. Schließlich, nachdem alle Schrauben installiert sind, ziehen Sie alle Schrauben auf 100%.

Wenn Sie auf diese Probleme stoßen, wie z. B. Fehlausrichtung der Löcher oder Unfähigkeit, bestimmte Teile zu installieren, überprüfen Sie bitte, ob die Schrauben korrekt verwendet werden und passen Sie die Dichtigkeit der Schrauben an.

UK:Before installation, insert the screws into the holes and tighten them, but do not tighten them to 100%, 70% to 80% is sufficient. Finally, after all screws are installed, tighten all screws to 100%.If you encounter these issues, such as if the holes cannot be aligned or some parts cannot be installed, please check if the screws are used correctly and adjust the tightness of the screws.

FR:Insérer la vis dans le trou avant la fin de l'assemblage, serrer la vis, mais ne pas serrer à 100%, 70% ~ 80% est correct. Enfin, une fois que toutes les vis sont bien serrées, toutes les vis sont serrées à 100%.

Si vous rencontrez ces problèmes, par exemple si les trous ne sont pas alignés ou si certaines pièces ne peuvent pas être montées, vérifiez que les vis sont utilisées correctement et Ajustez leur serrage.

IT: Prima dell'installazione, inserire le viti nei fori e stringerle, ma non al 100%, è sufficiente stringerle al 70% - 80%. Infine, dopo aver installato tutte le viti, stringere tutte le viti al 100%. Se riscontri problemi come disallineamenti dei fori o difficoltà nell'installare alcuni componenti, verifica che le viti siano utilizzate correttamente e regola la tensione delle viti.

ES: Antes de la instalación, coloque los tornillos en los agujeros y apriéte los, pero no al 100%; apretar al 70% - 80% es suficiente. Finalmente, después de haber instalado todos los tornillos, apriete todos los tornillos al 100%. Si se encuentra con problemas como desalineación de los agujeros o dificultad para instalar ciertas piezas, verifique que los tornillos se estén utilizando correctamente y ajuste la tensión de los tornillos.

NL: Voordat u begint met de installatie, plaatst u de schroeven in de gaten en draait u ze aan, maar draai ze niet volledig aan; 70% tot 80% is voldoende. Draai uiteindelijk, nadat alle schroeven zijn geplaatst, alle schroeven volledig aan. Als u problemen ondervindt, zoals niet uitgelijnde gaten of onderdelen die niet kunnen worden geïnstalleerd, controleer dan of de schroeven correct zijn gebruikt en pas de spanning van de schroeven aan.

SE: Innan installation, sätt i skruvarna i hålen och dra åt dem, men dra inte åt dem helt; 70% till 80% är tillräckligt. Slutligen, när alla skruvar är installerade, dra åt alla skruvar helt. Om du stöter på problem, som att hålen inte kan justeras eller vissa delar inte kan installeras, kontrollera om skruvarna används korrekt och justera skruvarnas åtdragning.

PL: Przed instalacją wstaw śruby w otwory i dokręć je, ale nie dokręcaj ich na 100%; 70% do 80% wystarczy. Na koniec, po zainstalowaniu wszystkich śrub, dokręć wszystkie śruby do 100%. Jeśli napotkasz problemy, takie jak niedopasowane otwory lub części, które niemogą być zainstalowane, sprawdź, czy śruby są używane prawidłowo i dostosuj ich dokręcenie.

## Verification of Compliance

**Verification No.:** MK24110278P01-C01  
**Name and address of Applicant:** Shenzhen Hongzhengyu Technology Co., LTD  
 Shenzhen baoan district rock street industrial science and technology industrial park of 2 Haitian lanyu 3 5 floor of A  
**Name and address of Manufacturer:** Shenzhen Hongzhengyu Technology Co., LTD  
 Shenzhen baoan district rock street industrial science and technology industrial park of 2 Haitian lanyu 3 5 floor of A  
**Product name:** LED strip light  
**Product model(s):** HZY-5050RGB-60D-5V  
**Product trademark:** N/A

This verification confirms that the product meets the requirements of the following standard. The conformity was demonstrated based on following standard(s) listed by European Commission as harmonized with Directive RoHS 2.0 Directive (EU) 2015/863 and (EU)2017/2102 amending Annex II to Directive 2011/65/EU

IEC 62321-1:2013	IEC 62321-3-1:2013
IEC 62321-4:2013/AMD1:2017	IEC 62321-5:2013
IEC 62321-6:2015	IEC 62321-7-1:2015
IEC 62321-7-2:2017	IEC 62321-8:2017
IEC 62321-2:2014	

The verification has been carried out in accordance with individual rules and conditions agreed with the applicant. Evaluation has been carried out in accordance with:

**Test report(s) No.:** MK24110278P01-C01  
**Test conducted by:** TMC Testing Services (Shenzhen) Co., Ltd.  
**Verification issue date:** December 04, 2024

**Notes:**

This verification refers to the above mentioned product and its conformity in regards of above mentioned standard(s) was proven on test sample.

This verification does not imply meeting all essential requirements, assessment of the series-production or any other restricted Notified Bodies conformity assessment procedure appropriate for the product.

This verification holder shall use this verification in connection to verification of conformity and technical data relevant for the product the verification was issued.

**TMC Testing Services (Shenzhen) Co., Ltd.**

t:86-755-86642861 cert@tmc-lab.com www.tmc-lab.com

1st Floor, Block A1, Zone A, Xinshidai Gongrong Industrial Park, No. 2, Shihuan Road, Shiyuan Street, Baoan District, Shenzhen, China



Importeur	Decobus Handel GmbH		
Adresse	Innungsstraße 9, 21244 Buchholz, Deutschland		
URL	<a href="https://www.decobusgroup.de">https://www.decobusgroup.de</a>		
Hersteller	Shenzhen Hongzhengyu Technology Co., LTD		
Adresse	Shenzhen baoan district rock street industrial science and technology, industrial park of 2 Haitian lanyu 3 5 floor of A		
Email/URL	522495222@qq.com		
Partienummer	N620P430611/N620P430612		
Hergestellt in	CHINA		
<table border="1" style="display: inline-table;"> <tr> <td>EC</td> <td>REP</td> </tr> </table>	EC	REP	Decobus Handel GmbH Innungsstraße 9, 21244 Buchholz, Deutschland <a href="https://www.decobusgroup.de">https://www.decobusgroup.de</a>
EC	REP		



Produkt: LED-Lichtstreifen  
 Modell: HZY-5050RGB-60D  
 Nennspannung: 5V  
 Leistung: 4.5W/M

## Attestation of Compliance

**Declaration No.:** MK23110141P01-E01  
**Name and address of Applicant:** Shenzhen Hongzhengyu Technology Co., LTD  
 Shenzhen baoan district rock street industrial science and technology industrial park of 2 Haitian lanyu 3 5 floor of A  
**Name and address of Manufacturer:** Shenzhen Hongzhengyu Technology Co., LTD  
 Shenzhen baoan district rock street industrial science and technology industrial park of 2 Haitian lanyu 3 5 floor of A  
**Product name:** RGB package  
**Rated:** DC5V  
 HZY-5050RGB-30D-90R-DC5V, HZY-5050RGB-30D-30R-DC5V,  
**Product model(s):** HZY-5050RGB-60D-60R-DC5V, HZY-5050RGB-60D-180R-DC5V, HZY-5050RGB-18D-18R-DC5V  
**Product trademark:** N/A

This Attestation of Compliance confirms that the product meets the requirements of the following standard.

BS EN IEC 55015:2019+A11:2020  
 IEC 61547:2020  
 BS EN IEC 61000-3-2:2019  
 BS EN 61000-3-3:2013/A2:2021

The Attestation of Compliance has been carried out in accordance with individual rules and conditions agreed with the applicant. Evaluation has been carried out in accordance with:

**Test report(s) No.:** MK23110141P01-E01  
**Test conducted by:** TMC Testing Services (Shenzhen) Co., Ltd.  
**Declaration issue date:** December 5, 2023

**Notes:**

This Attestation of Compliance is issued according to the Great Britain legislation Electromagnetic Compatibility Regulations 2016( SI 2016 No. 1091). It confirms that the listed products complies with all essential requirements of the Regulations and applies only to the sample and its technical documentation to TMC Testing Services (Shenzhen) Co., Ltd. for testing.

After preparation of the necessary technical documentation (which must be kept for up to 10 years after the product is placed on the GB market) as well as the UK Declaration of Conformity, the required UKCA marking can be affixed on the product. Other relevant Regulations have to be observed.

**TMC Testing Services (Shenzhen) Co., Ltd.**

t:86-755-86642861 cert@tmc-lab.com www.tmc-lab.com  
 1st Floor, Block A1, Zone A, Xinshidai Gongrong Industrial Park, No. 2, Shihuan Road, Shiyan Street, Baoan District, Shenzhen, China



TMC

<b>Importer</b>	COMHARBOR LIMITED		
<b>Add</b>	Unit C, Swift Point, Cosford Lane, Rugby, CV21 1PY,GB		
<b>Email/URL</b>	harborcomhar@gmail.com		
<b>Manufacturer</b>	Shenzhen Hongzhengyu Technology Co., LTD		
<b>Add</b>	Shenzhen baoan district rock street industrial science and technology, industrial park of 2 Haitian lanyu 3 5 floor of A		
<b>Email/URL</b>	522495222@qq.com		
<b>Product identification</b>	N639P430642/N639P430643		
<b>Made in</b>	CHINA		
<table border="1" style="display: inline-table;"> <tr> <td>UK</td> <td>REP</td> </tr> </table>	UK	REP	COMHARBOR LIMITED Unit C, Swift Point, Cosford Lane, Rugby, CV21 1PY,GB harborcomhar@gmail.com
UK	REP		



Product Name: LED-light strip  
 Model: HZY-5050RGB-60D  
 Rated voltage: 5V  
 Power: 4.5W/M

Shenzhen ZKT Technology Co., Ltd.  
 1/F, No. 101, Building B, No. 6, Tangwei Community Industrial Avenue,  
 Fuhai Street, Bao'an District, Shenzhen, China



# Certificate of Compliance

Certificate Number: ZKT-25070215182C

**Certificate's Holder** : Dongguan Yihong Hardware Electronics Co., Ltd  
 Room 1106, No.2, Shangheng Road, Chang' an Town,  
 Dongguan

**Manufacturer** : Dongguan Yihong Hardware Electronics Co., Ltd  
 Room 1106, No.2, Shangheng Road, Chang' an Town,  
 Dongguan

**Trade Mark** : N/A

**Product** : LED controller

**Model(s)** : YH-6183  
 YH-252, YH-284, YH-290, YH-287, YH-358, YH-360, YH-6180,  
 YH-6184

Requirement	Standard	Report No.
Art.3.1(a) Safety	EN IEC 62368-1:2024+A11:2024	ZKT-25070215183S
Art.3.1(a) Health	EN IEC 62311:2020 EN 50665:2017	ZKT-25070215182E-1
Art.3.1(b) EMC	ETSI EN 301 489-1 V2.2.3 (2019-11) ETSI EN 301 489-17 V3.3.0 (2024-07)	ZKT-25070215182E-2
Art.3.2 Radio	ETSI EN 300 328 V2.2.2 (2019-07)	ZKT-25070215182E-3

This Attestation of Compliance is issued on a voluntary basis for electrical equipment below the voltage limits of Radio Equipment Directive (RED) 2014/53/EU. The essential requirements are fulfilled accordingly based on the technical specifications applicable at the time of issuance.



This Certificate of Conformity is based on single evaluation of the submitted sample(s) of the above mentioned product. It does not imply an assessment of the whole product and relevant Directives to be observed.

☎ +86-400 000 9970    📠 +86-755-22336688    ✉ zkt@zkt-lab.com    🌐 www.zkt-lab.com

<b>Importeur</b>	Decobus Handel GmbH
<b>Adresse</b>	Innungsstraße 9,21244 Buchholz, Deutschland
<b>URL</b>	<a href="https://www.decobusgroup.de">https://www.decobusgroup.de</a>
<b>Hersteller</b>	Dongguan Yihong Hardware electronics Co., LTD
<b>Adresse</b>	Room 901, No. 2, Shangheng Road, Chang'an Town, Dongguan City, Guangdong Province, 523880 China
<b>Email/URL</b>	410474484@qq.com
<b>Partienummer</b>	N620P430611/N620P430612
<b>Hergestellt in</b>	CHINA
<b>EC REP</b>	Decobus Handel GmbH Innungsstraße 9, 21244 Buchholz, Deutschland <a href="https://www.decobusgroup.de">https://www.decobusgroup.de</a>

<b>Importer</b>	COMHARBOR LIMITED
<b>Add</b>	Unit C, Swift Point, Cosford Lane, Rugby, CV21 1PY,GB
<b>Email/URL</b>	harborcomhar@gmail.com
<b>Manufacturer</b>	Dongguan Yihong Hardware electronics Co., LTD
<b>Add</b>	Room 901, No. 2, Shangheng Road, Chang'an Town, Dongguan City, Guangdong Province, 523880 China
<b>Email/URL</b>	410474484@qq.com
<b>Product identification</b>	N639P430642/N639P430643
<b>Made in</b>	CHINA
<b>UK REP</b>	COMHARBOR LIMITED Unit C, Swift Point, Cosford Lane, Rugby, CV21 1PY,GB harborcomhar@gmail.com



Produkt: LED-Streifen-Controller  
 Modell: YH-358  
 Nennspannung: 5V  
 Leistung: 4.5W/M



Product Name: LED-light strip-Controller  
 Model: YH-358  
 Rated voltage: 5V  
 Power: 4.5W/M

## CERTIFICATE OF CONFORMITY

No.: PTC25102309602C-EN01V02

**Applicant** : Dongguan Yihong Hardware electronics Co., LTD  
**Address** : Room 901, No. 2, Shangheng Road, Chang'an Town, Dongguan City, Guangdong Province, 523880 China  
**Manufacturer** : Dongguan Yihong Hardware electronics Co., LTD  
**Address** : Room 901, No. 2, Shangheng Road, Chang'an Town, Dongguan City, Guangdong Province, 523880 China  
**Product Name** : LED Controler  
**Model No.** : YH-289,YH-980 ,YH-284 ,YH-917 ,YH-818,YH-816,YH-6181,YH-358

The submitted sample of the above equipment has been tested and found to comply with the following European Directive:

RoHS Directive 2011/65/EU & EU No.2015/863

The standard(s) used for showing compliance with the essential requirements:

Applicable Standard(s)	Test Report(s) Number
IEC 62321-1:2013, IEC 62321-2:2021 IEC 62321-3-1:2013, IEC 62321-3-2:2020 IEC62321-4: 2013+AMD1:2017 IEC 62321-5:2013 IEC 62321-6:2015, IEC 62321-7-1: 2015 IEC 62321-7-2: 2017, IEC 62321-8:2017	PTC25102309602C-EN01V02

This certificate is part of the full test report(s) and should be read in conjunction with it. This certificate is based on an evaluation of one sample of above mentioned product. It does not imply assessment of the production of the product. Without the written approval of Precise Testing & Certification (Guangdong) Co., Ltd., this certificate is not permitted to be reproduced, except in full. It is not permitted to use the test lab's logo.

# RoHS



Jacky Ou  
 Manager  
 Date: Dec. 11, 2025





## Verification of Compliance

<b>Verification No.:</b>	MK24030235P01-S01
<b>Name and address of Applicant:</b>	<b>Shenzhen Hongzhengyu Technology Co., LTD</b> Shenzhen baoan district rock street industrial science and technology industrial park of 2 Haitian lanyu 3 5 floor of A
<b>Name and address of Manufacturer:</b>	<b>Shenzhen Hongzhengyu Technology Co., LTD</b> Shenzhen baoan district rock street industrial science and technology industrial park of 2 Haitian lanyu 3 5 floor of A
<b>Product name:</b>	<b>LED Lamp Strip</b>
<b>Rated:</b>	DC5V, 2A, Max.10W HZY-2835-120D-12V, HZY-2835-30D-5V, HZY-2835-60D-5V, HZY-2835-120D-5V, HZY-2835-60D-12V, HZY-2835-60D-24V, HZY-2835-120D-24V, HZY-2835RGB-60D-5V, HZY-2835RGB-60D-12V, HZY-5050-30D-5V, HZY-5050-60D-5V, HZY-5050-30D-12V, HZY-5050-60D-12V, HZY-5050-60D-24V, HZY-5050RGB-30D-5V, HZY-5050RGB-60D-5V, HZY-5050RGB-30D-12V, HZY-5050RGB-60D-12V, HZY-5050RGB-60D-24V
<b>Product model(s):</b>	
<b>Product trademark</b>	N/A

This verification confirms that the product meets the requirements of the following standard.  
The conformity was demonstrated based on following standard(s) listed by European Commission as harmonized with LVD Directive 2014/35/EU.

EN IEC 60598-2-1:2021;

EN IEC 60598-1:2021+ A11:2022

The verification has been carried out in accordance with individual rules and conditions agreed with the applicant. Evaluation has been carried out in accordance with:

<b>Test report(s) No.:</b>	MK24030235P01-S01
<b>Test conducted by:</b>	TMC Testing Services (Shenzhen) Co., Ltd.
<b>Verification issue date:</b>	April 9, 2024

**Notes:**

This verification refers to the above mentioned product and its conformity in regards of above mentioned standard(s) was proven on test sample.

This verification does not imply meeting all essential requirements, assessment of the series-production or any other restricted Notified Bodies conformity assessment procedure appropriate for the product.

This verification holder shall use this verification in connection to Verification of Compliance and technical data relevant for the product the verification was issued.

**TMC Testing Services (Shenzhen) Co., Ltd.**

t:86-755-86642861 cert@tmc-lab.com www.tmc-lab.com

1/F., Block A, Xinshidai Gongrong Industrial Park, No. 2, Shihuan Road, Shilong Community, Shiyan Street, Baoan District, Shenzhen, China





## Verification of Compliance

**Verification No.:** MK24110278P01-E01  
**Name and address of Applicant:** Shenzhen Hongzhengyu Technology Co., LTD  
 Shenzhen baoan district rock street industrial science and technology industrial park of 2 Hallian lanyu 3 5 floor of A  
**Name and address of Manufacturer:** Shenzhen Hongzhengyu Technology Co., LTD  
 Shenzhen baoan district rock street industrial science and technology industrial park of 2 Hallian lanyu 3 5 floor of A  
**Product name:** LED strip light  
**Rated:** 5V  
**Product model(s):** HZY-5050RGB-60D-5V  
**Product trademark:** N/A

This verification confirms that the product meets the requirements of the following standard. The conformity was demonstrated based on following standard(s) listed by European Commission as harmonized with EMC Directive 2014/30/EU.

EN IEC 55015:2019+A11:2020  
 EN IEC 61547:2023

*The verification has been carried out in accordance with individual rules and conditions agreed with the applicant. Evaluation has been carried out in accordance with:*

**Test report(s) No.:** MK24110278P01-E01  
**Test conducted by:** TMC Testing Services (Shenzhen) Co., Ltd.  
**Verification issue date:** December 04, 2024

**Notes:**

*This verification refers to the above mentioned product and its conformity in regards of above mentioned standard(s) was proven on test sample.*

*This verification does not imply meeting all essential requirements, assessment of the series-production or any other restricted Notified Bodies conformity assessment procedure appropriate for the product.*

*This verification holder shall use this verification in connection to verification of conformity and technical data relevant for the product the verification was issued.*

**TMC Testing Services (Shenzhen) Co., Ltd.**

t:86-755-86642861 cert@tmc-lab.com www.tmc-lab.com

1st Floor, Block A1, Zone A, Xinshidai Gongrong Industrial Park, No. 2, Shihuan Road, Shiyuan Street, Baoan District, Shenzhen, China

