

Assembly Instructions

Caution : You must read this before you proceed

Please look behind the product for hardware packs and legs

TABLE

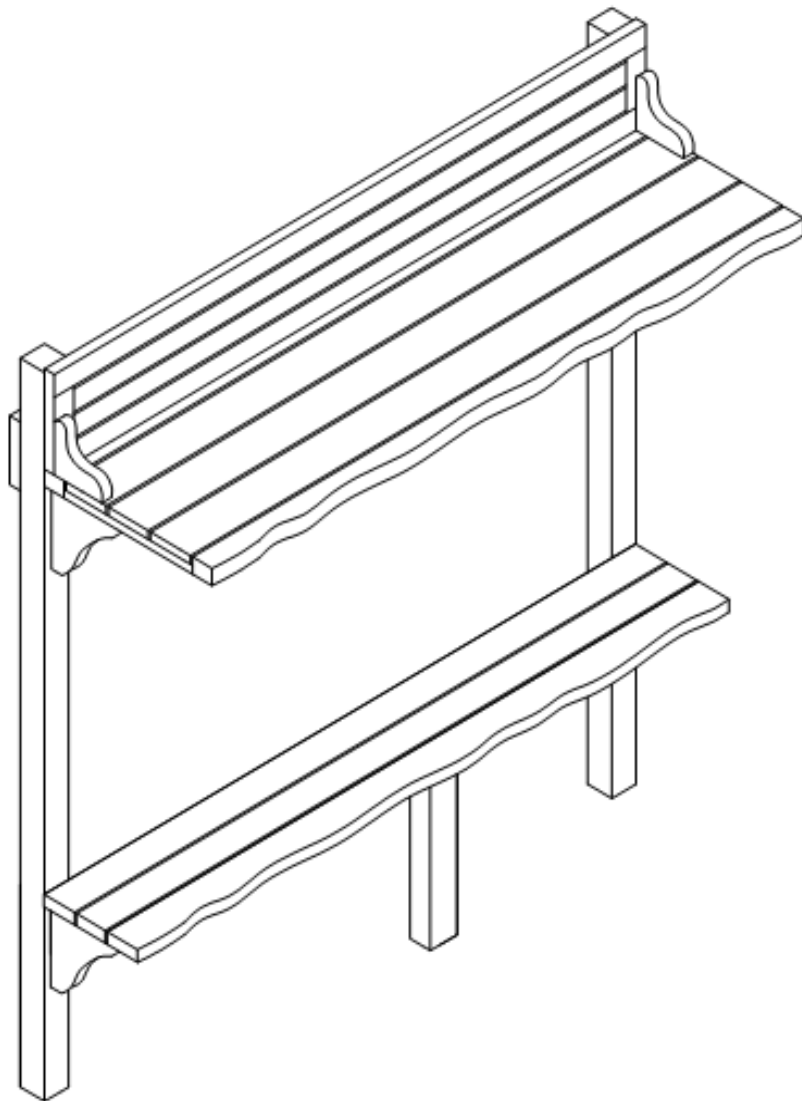





CAUTION : This Table is NOT a TOY.



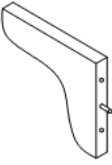
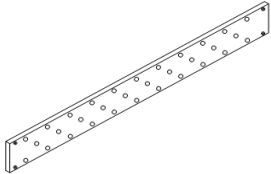

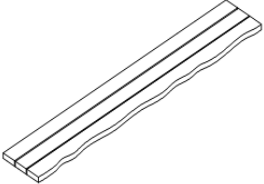
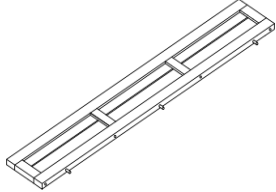
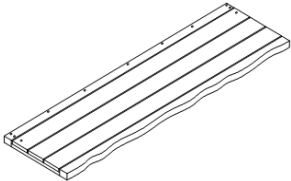



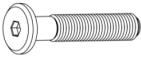
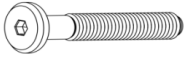

Keep your child / children at bay during the assembly process.

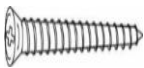
For moving the Table and to prevent damage to the Table, two adults are needed to execute this action.

Parts List

Label	Picture	Description	QTY
A		Long Legs with pre-attached Support Wing.	2
B		Lower Support Wings	2
C		Table Support Bar	1
D		Short leg (for the Footrest Shelf)	1
E		Footrest shelf	1
F		Back panel	1
G		Table top	1
H		Upper Support Wings	2

Hardware

Label	Picture	Description	QTY
①		Short Bolt (M6 x 35mm)	5
②		Long Bolt (M6 x 55mm)	13
③		Long Screw (M6x45)	9
④		Screw (M4 x 20mm) (used with Screw Driver)	5
⑤		Nut Ø6 x 6	13
⑥		Plate for Horseshoe Bolt (125 x 15 x 2)	2
⑦		Horseshoe Bolt Ø6 x (150 + 106 + 150)	2
⑧		Washer	9
⑨		Restraint Strap	2
⑩		Allen Wrench	2
⑪		Spanner	1
⑫		Screw Driver	Not Provided

Assembly Preparation

Before Beginning Assembly:

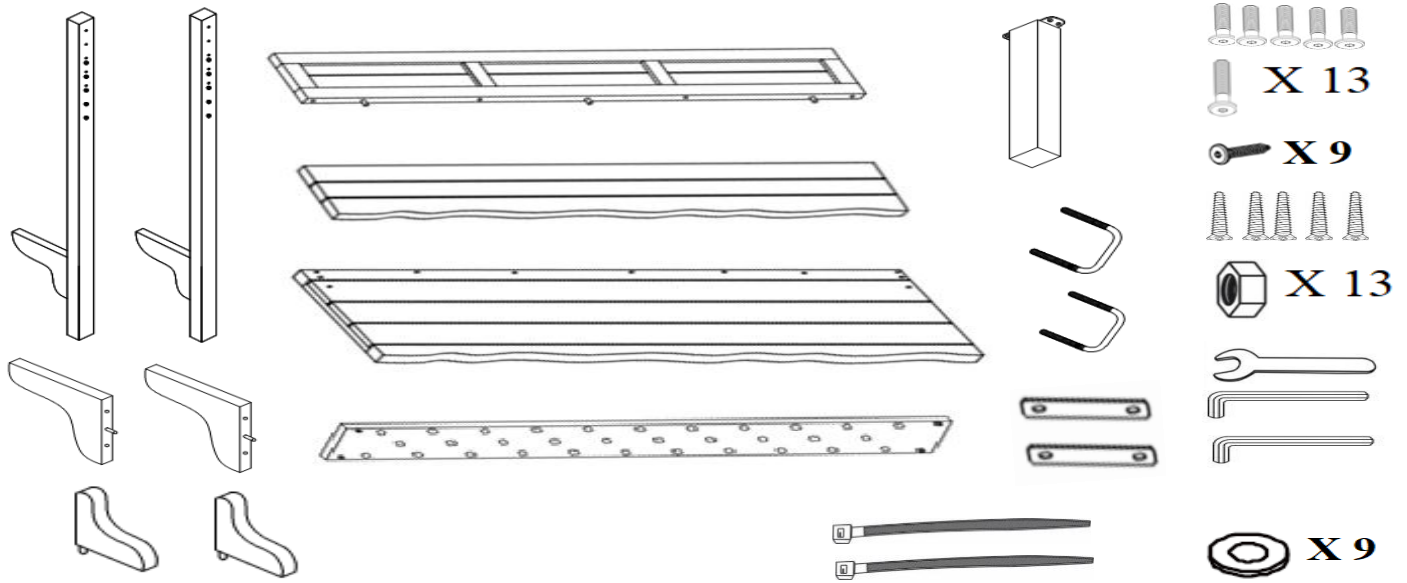

- Read instructions, cover to cover-



- Have 2 adults on hand for assembly-



- Do not assemble on flooring or carpet-



- Assemble on a clean non-marring surface (packing foam)-



- Save all packaging until finished-

Assembly Steps

OVERVIEW

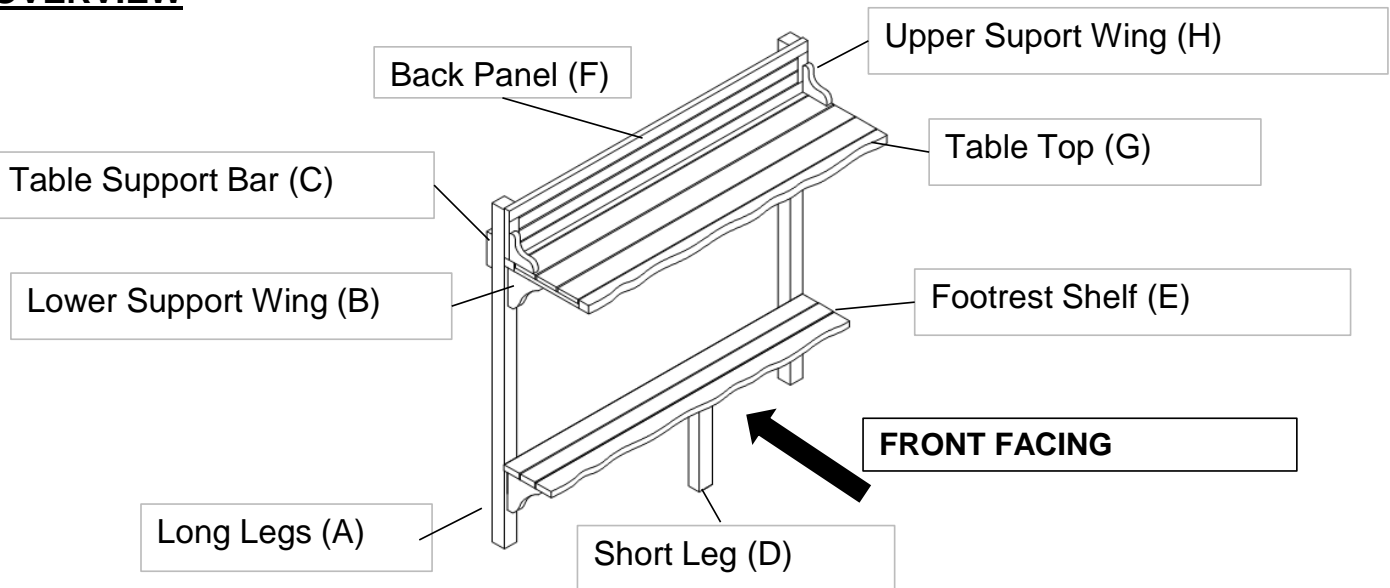

This Table has multiple parts and may require up to some 30 minutes to assemble. To give you an overview of the Table, the above picture aims help you put the various parts into perspective. Please read through the instructions here below to familiarise the parts and steps before assembly.

Note: This table may be assembled by 1 to 2 people.

Step 1

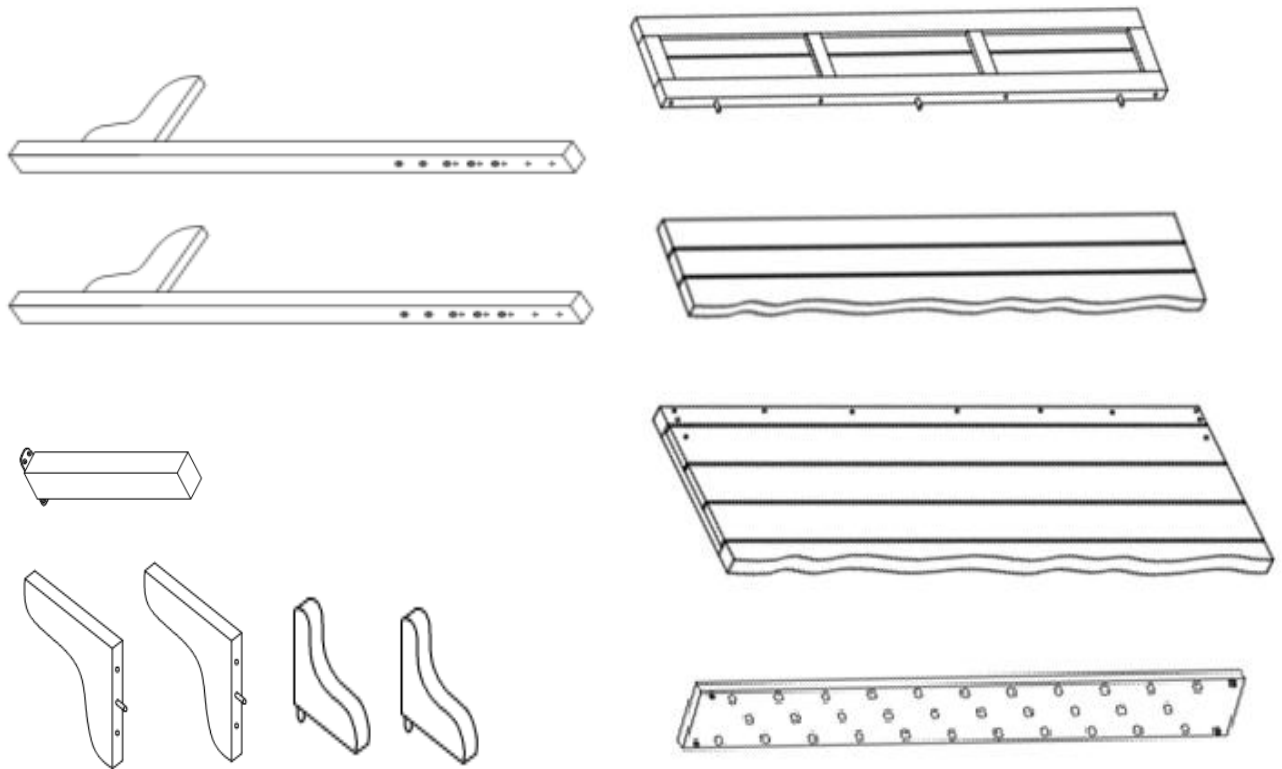

Unpack and place all parts on a clean, non-marring surface.

Step 2

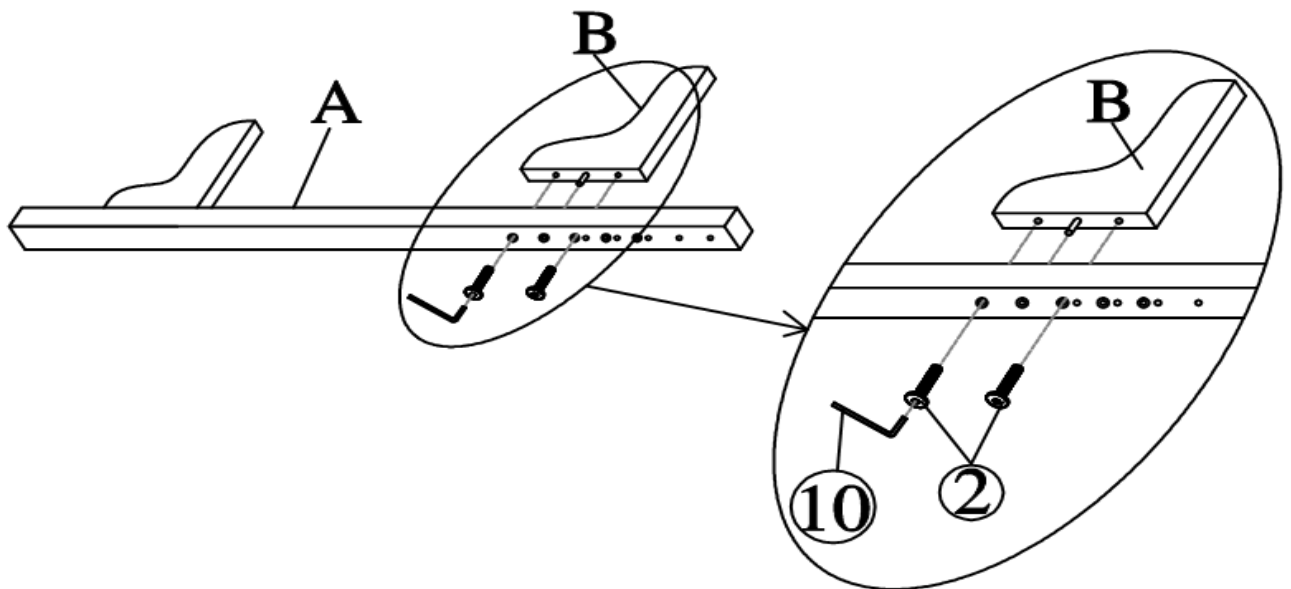

Customer need to check the railing height, matching to table height, before assembly of Lower Support Wing (B).

Attached Long Leg(A) with pre-fixed wooden dowel to the Lower Support Wing(B) using Short Bolt(2) and Allen Wrench(10).

Repeat the same process with the other Long Leg(A).

DO NOT FULLY TIGHTEN THE BOLTS.

Step 3

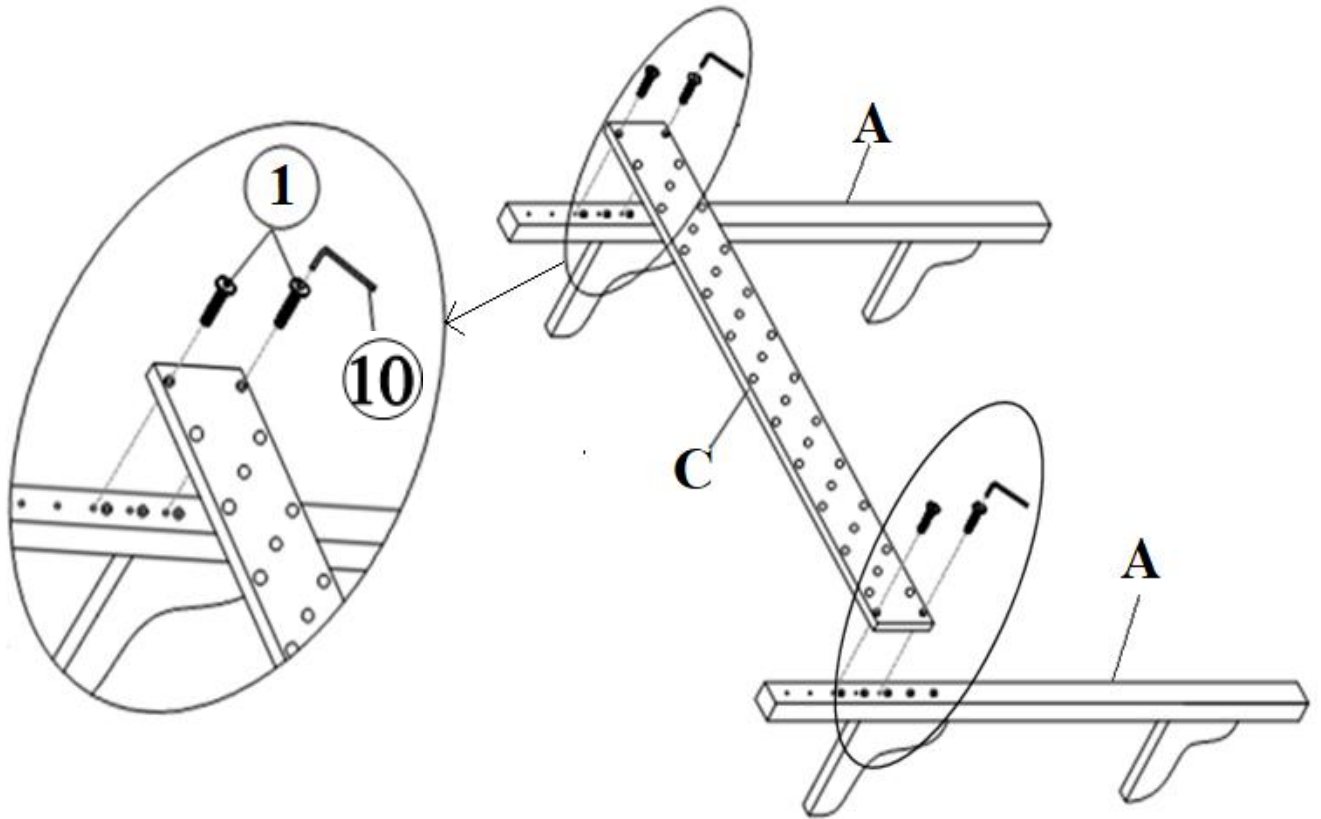

Customer need to check the railing height before assembly the part C.
Attached Table Support Bar(C) with Long Legs(A) using Short Bolt(①) and Allen Wrench(⑩) as shown in picture.
Upon completion - place aside.
DO NOT FULLY TIGHTEN THE BOLTS.

Step 4

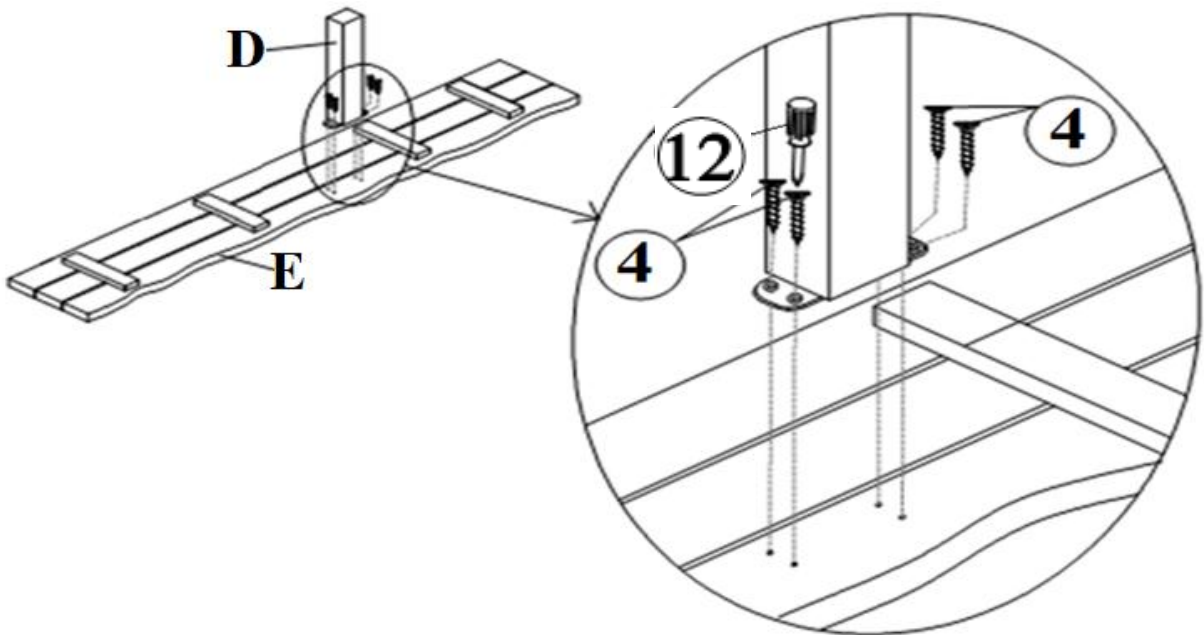

Using Screw Driver(⑫) and Screws(④) to assemble the Short Leg(D) to the Footrest Shelf(E) as shown in picture.
Upon completion of assembly - place aside.
Note: Adjust the Levelers to desired height to avoid wobble.
DO NOT FULLY TIGHTEN THE SCREWS

Step 5

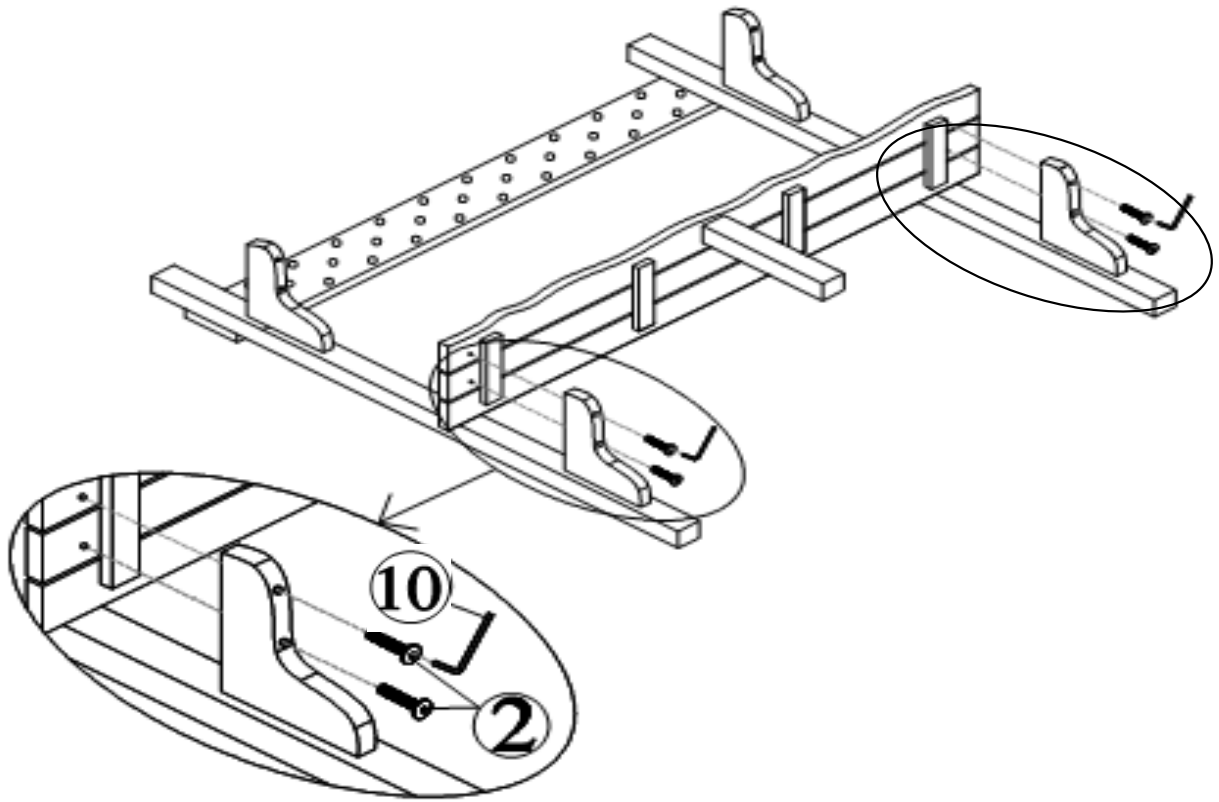

Lay down pre-fixed table in Step 3.

Assemble pre-fixed table in Step 3 and Step 4 together by using Long Bolts(②) and Allen Wrench(⑩) as shown in picture.

DO NOT FULLY TIGHTEN THE BOLTS.

Step 6

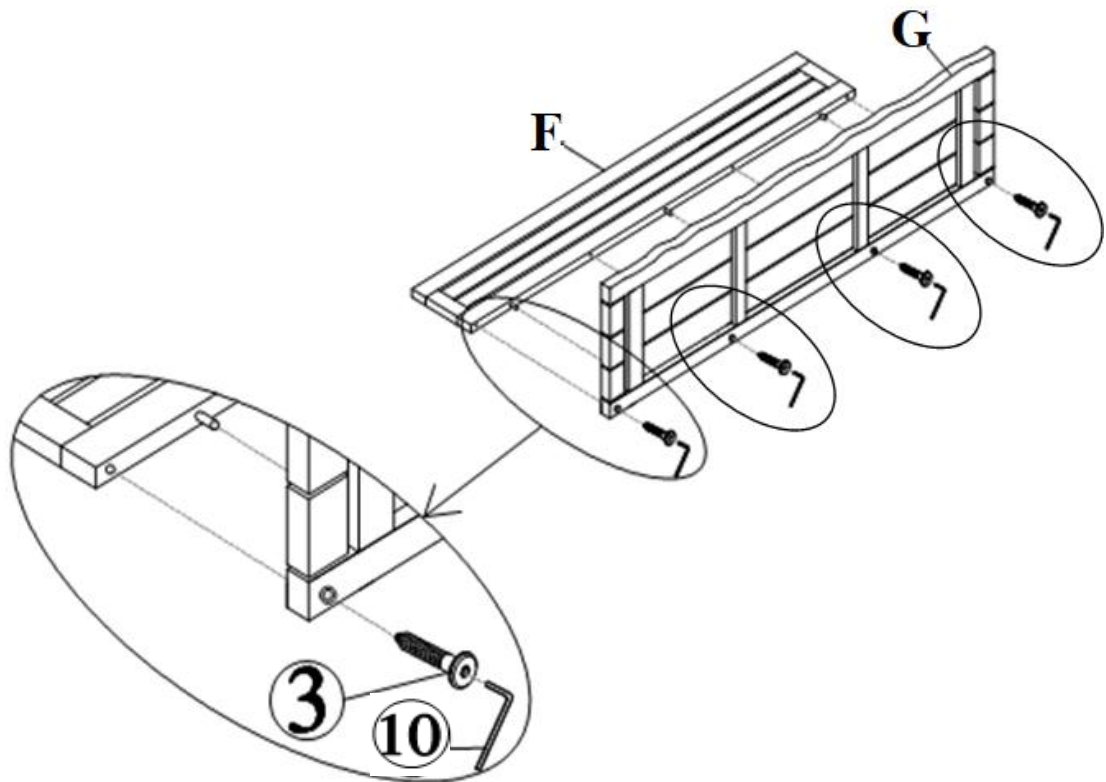

Assembly the Table Top(G) to the Back Panel(F) by using Allen Wrench(⑩) to tighten the Long Screws(③) in.

DO NOT FULLY TIGHTEN THE SCREWS.

Step 7

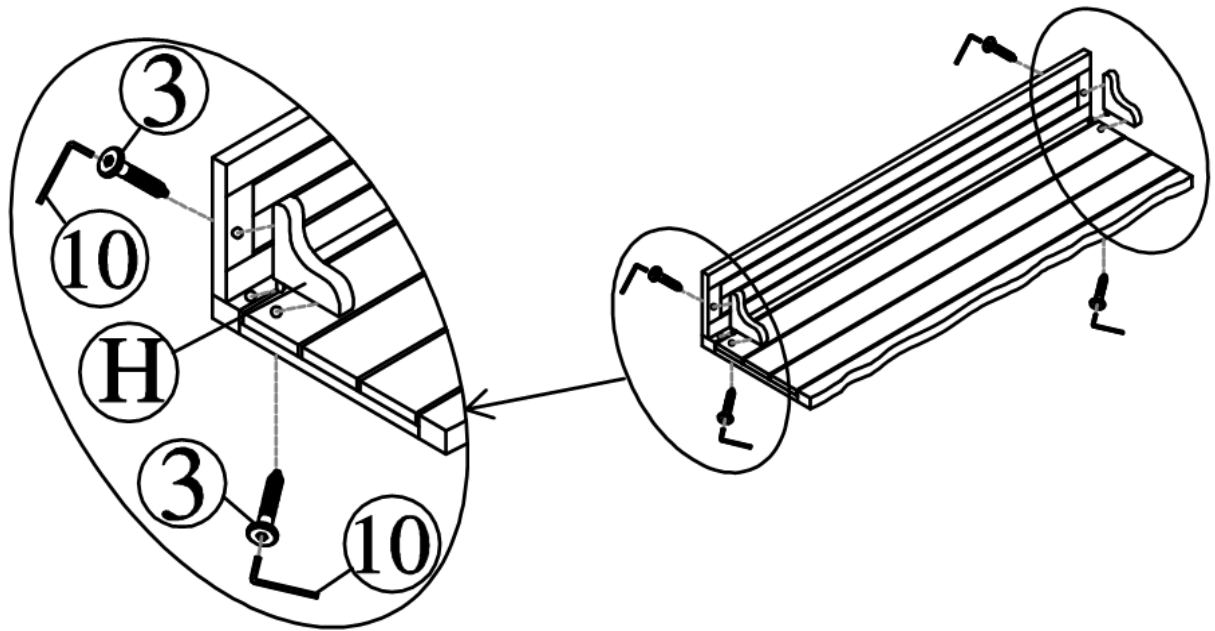

Assembly Upper Support Wings(H) to finish part in Step 6 by using Long Screws(③) and Allen Wrench(⑩) as shown in picture .
Upon completion - place aside.
DO NOT FULLY TIGHTEN THE SCREWS.

Step 8

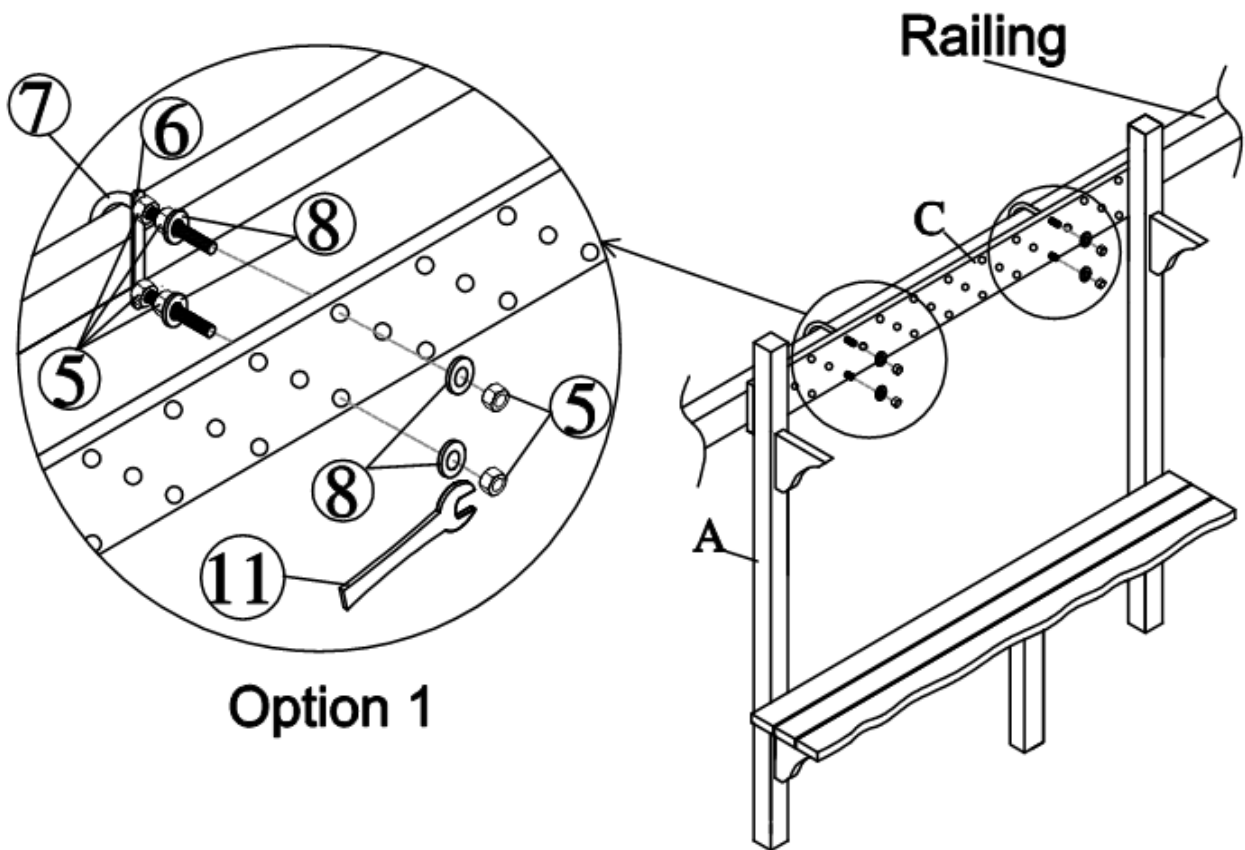

With assistance from your adult partner, stand pre-fixed table in Step 5, right side up.
Attach the Table Support Bar(C) to your balcony (railing) by using Horseshoe Bolt(⑦),
Plate(⑥), Washer(⑧), Nut(⑤) and Spanner(⑪) as shown in picture.
DO NOT FULLY TIGHTEN THE NUTS.

Step 9

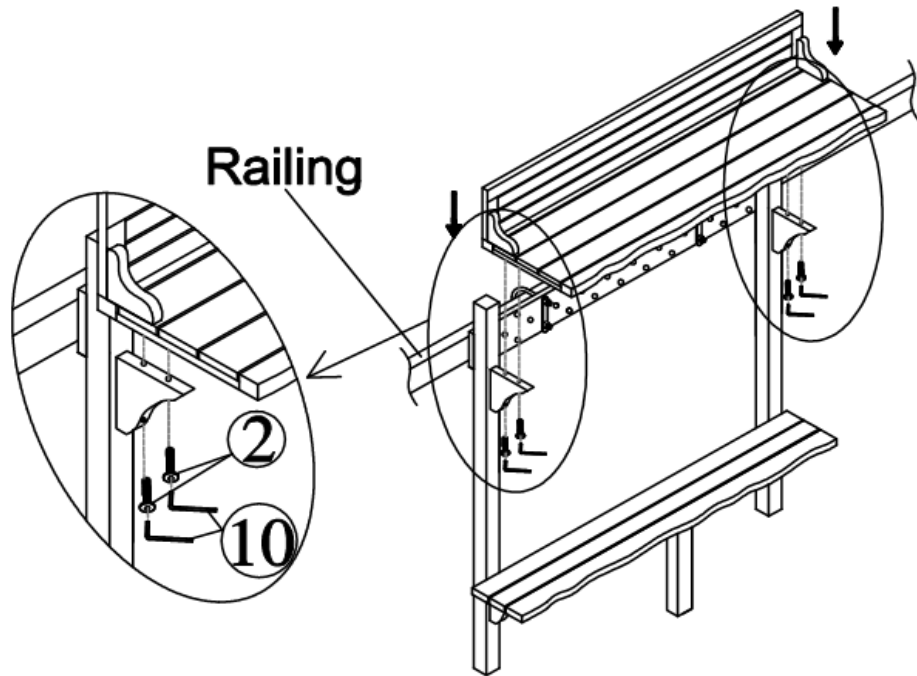





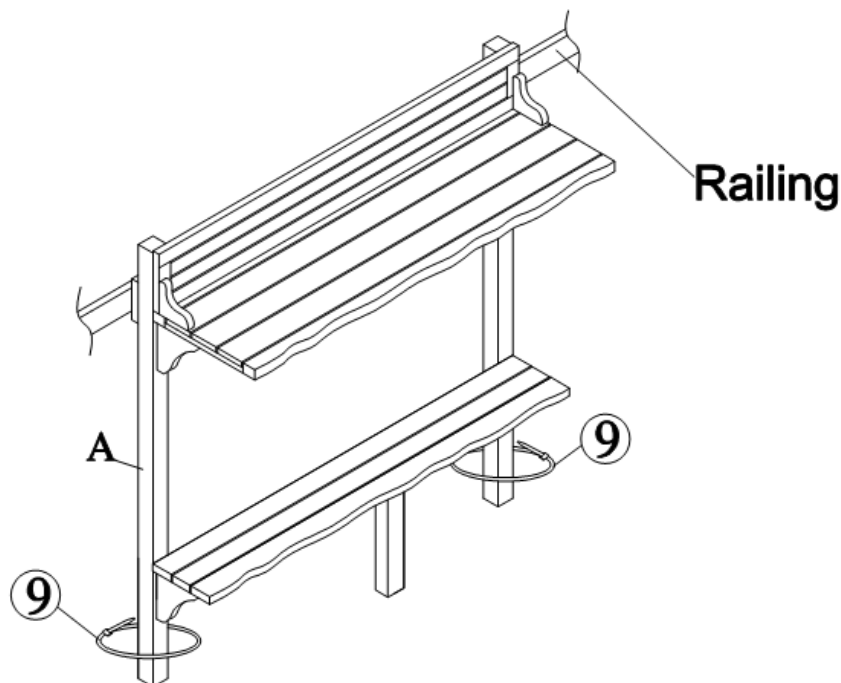



Assemble pre-fixed table from Step 7 and Step 8 together by using Long Bolts(②) and Allen Wrench(⑩) as shown in picture.
DO NOT FULLY TIGHTEN THE BOLTS.

Step 10

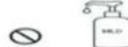

Next, place your arms onto the table top and EXERT pressure, floorwards. This pressure will help all parts reach alignment at all joints. Check for wobbles. In a sequential manner, gradually tighten all Bolts/Screws until evenly secured. Inspect the Table and make sure all parts are adequately connected. Secure the Long Legs(A) to your balcony (railing) by using Restraint Strap(⑨) as shown in picture. This completes the entire assembly process and your table is ready for use.
This Table can only be used on a flat, level surface.

Care & Maintenance

-  Do not put hot items directly on furniture surface
 -  Do not clean furniture with harsh cleansers or polish.
 -  To obtain the longest lifespan of your outdoor products, minimizing exposure to direct sunlight is recommended.
 -  Children should not climb or jump on the furniture.
 -  Do not write on furniture without a padded barrier to protect the
 -  To obtain the longest lifespan of your outdoor products, avoid extended and lengthy exposure to rain, snow, and direct sunshine. Whenever possible cover the product and /or place under patio or awnings.
 -  Not for commercial use. For residential use only .
 -  Stains may be removed with mild soap solution and damp cloth.
-
-  Dust and pick-up spills using a clean, non-colored, lint-free cloth .