

ASSEMBLY INSTRUCTIONS

INSTRUCTIONS DE MONTAGE

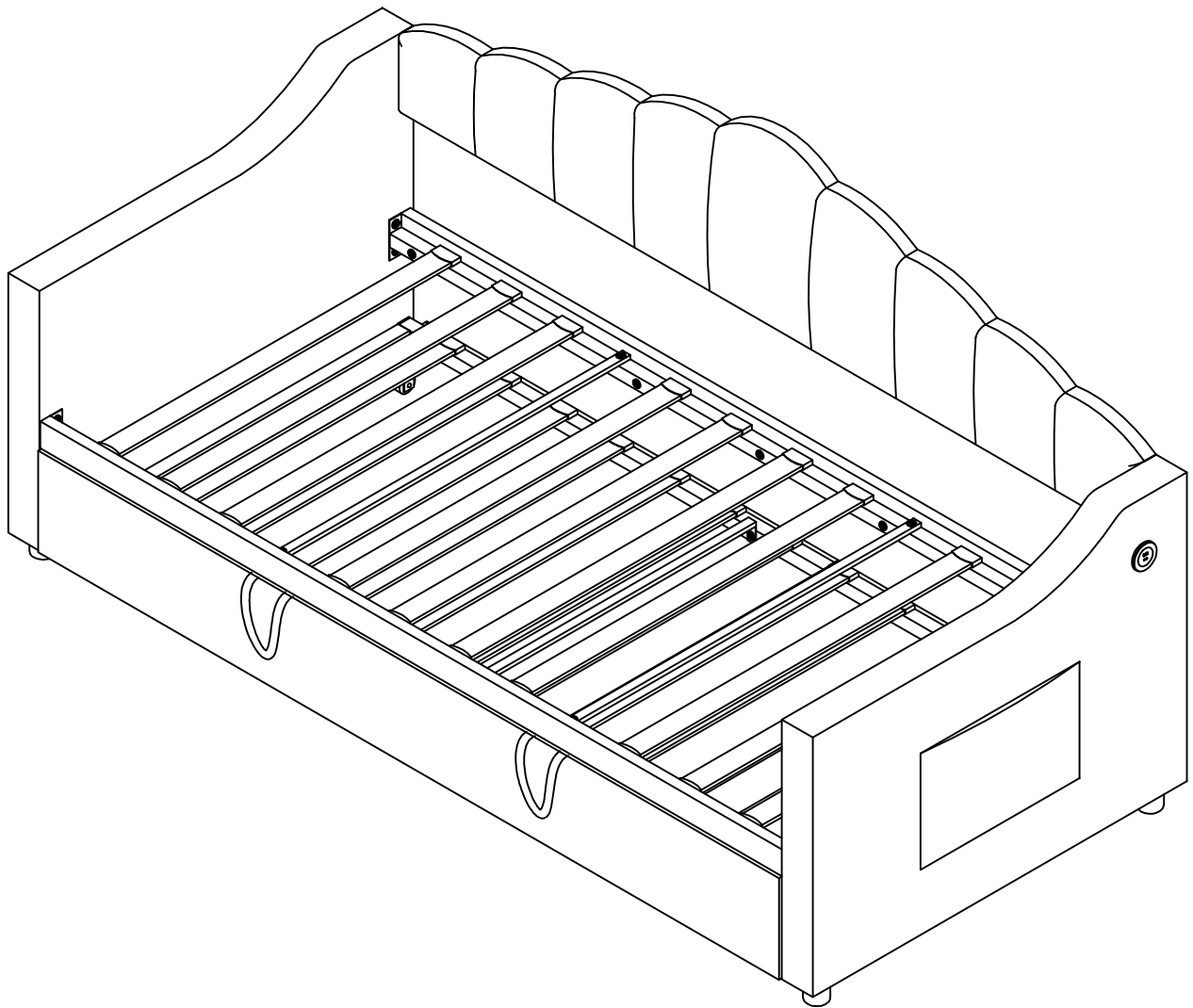

ASSEMBLY INSTRUCTIONS

INSTRUCTIONS DE MONTAGE

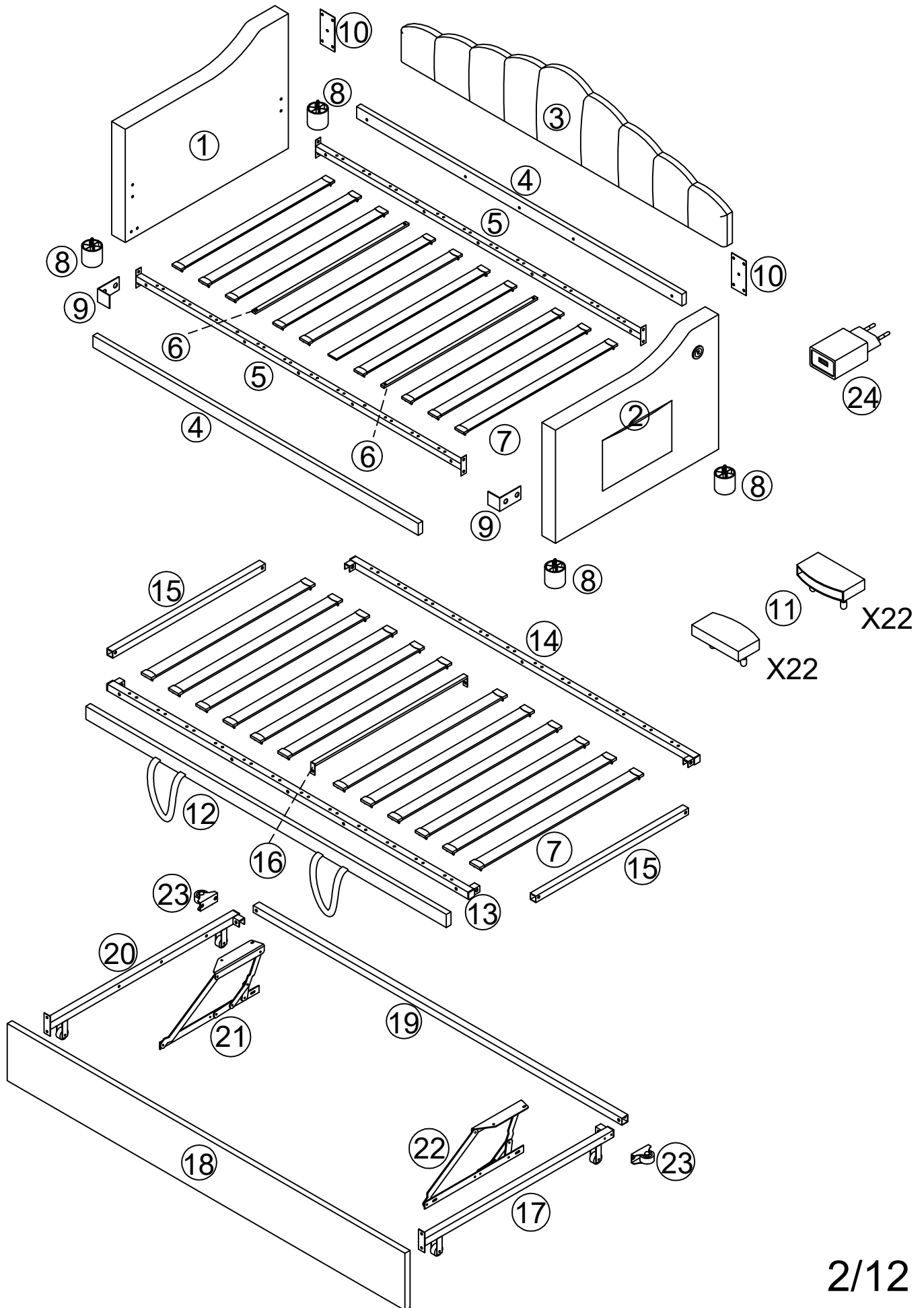

Part List

Liste de pièces

(BOX-1/2)

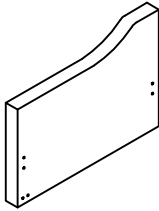
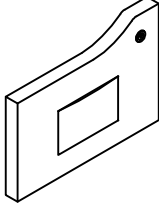
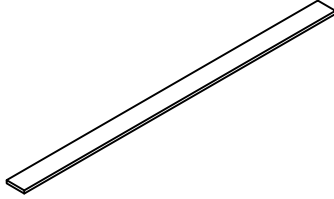
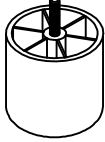
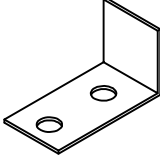
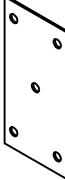
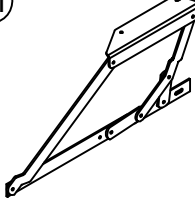
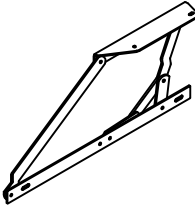
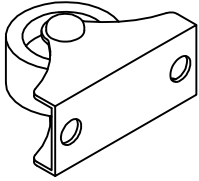
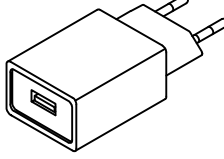
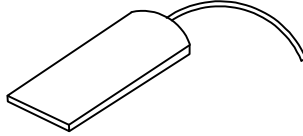

<p>①</p>  <p>x 1</p>	<p>②</p>  <p>x 1</p>	<p>⑦</p>  <p>x 22</p>		
<p>⑧</p>  <p>x 4</p>	<p>⑨</p>  <p>x 2</p>	<p>⑩</p>  <p>x 2</p>	<p>⑳</p>  <p>x 1</p>	<p>㉒</p>  <p>x 1</p>
<p>㉓</p>  <p>x 2</p>	<p>㉔</p>  <p>x 1</p>	<p>hardware kit</p> 		

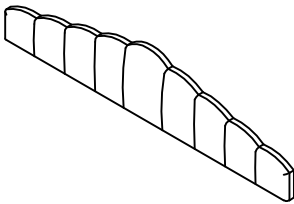
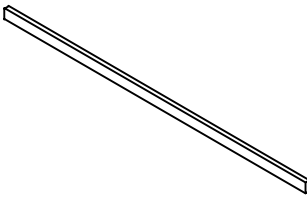
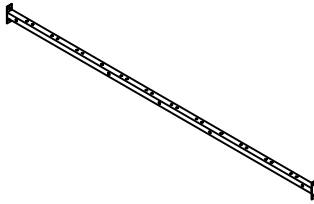
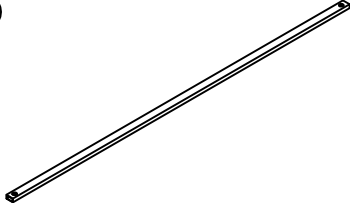
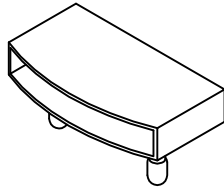
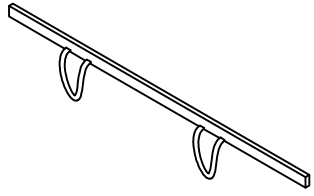
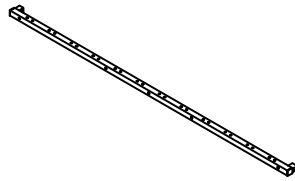
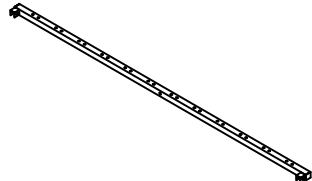
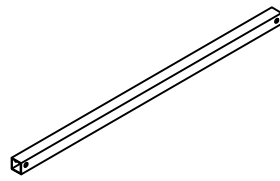
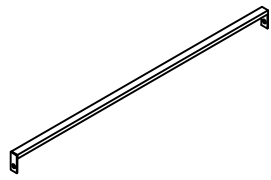
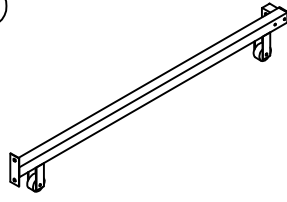
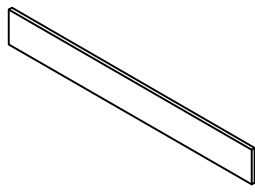
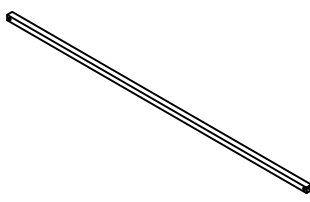
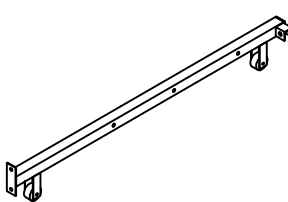
(BOX-2/2)

<p>③</p>  <p>x 1</p>	<p>④</p>  <p>x 2</p>	<p>⑤</p>  <p>x 2</p>
<p>⑥</p>  <p>x 2</p>	<p>⑪</p>  <p>x 44</p>	<p>⑫</p>  <p>x 1</p>
<p>⑬</p>  <p>x 1</p>	<p>⑭</p>  <p>x 1</p>	<p>⑮</p>  <p>x 2</p>
<p>⑯</p>  <p>x 1</p>	<p>⑰</p>  <p>x 1</p>	<p>⑱</p>  <p>x 1</p>
<p>㉑</p>  <p>x 1</p>	<p>㉒</p>  <p>x 1</p>	<p>3/12</p>

Hardware List

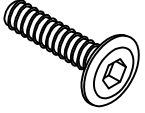
Liste de matériel

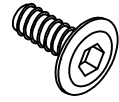
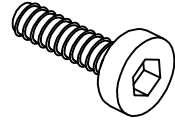
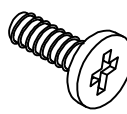
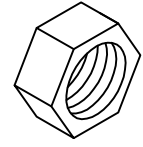
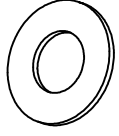
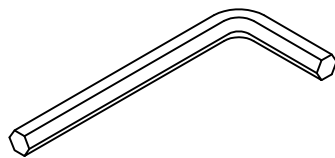
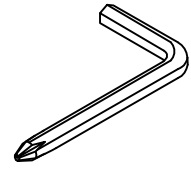
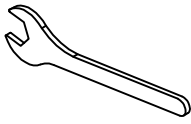
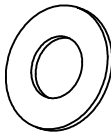
<p>Ax21 PCS</p>  <p>5/16X45mm</p>	<p>Bx32 PCS</p>  <p>5/16X25mm</p>	<p>Cx5 PCS</p>  <p>5/16X15mm</p>
<p>Dx4 PCS</p>  <p>1/4X25mm</p>	<p>Ex4 PCS</p>  <p>M4X15mm</p>	<p>Fx6 PCS</p>  <p>5/16</p>
<p>Gx6 PCS</p>  <p>Ø19X5/16</p>	<p>Hx1 PC</p>  <p>5/16</p>	<p>Jx1 PC</p>  <p>1/4</p>
<p>Kx1 PC</p>  <p>5/16</p>	<p>Lx4 PCS</p>  <p>Ø16X1/4</p>	

STEP 1
ETAPE 1

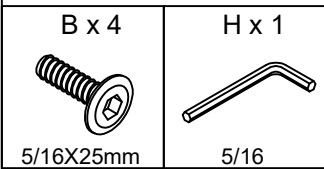
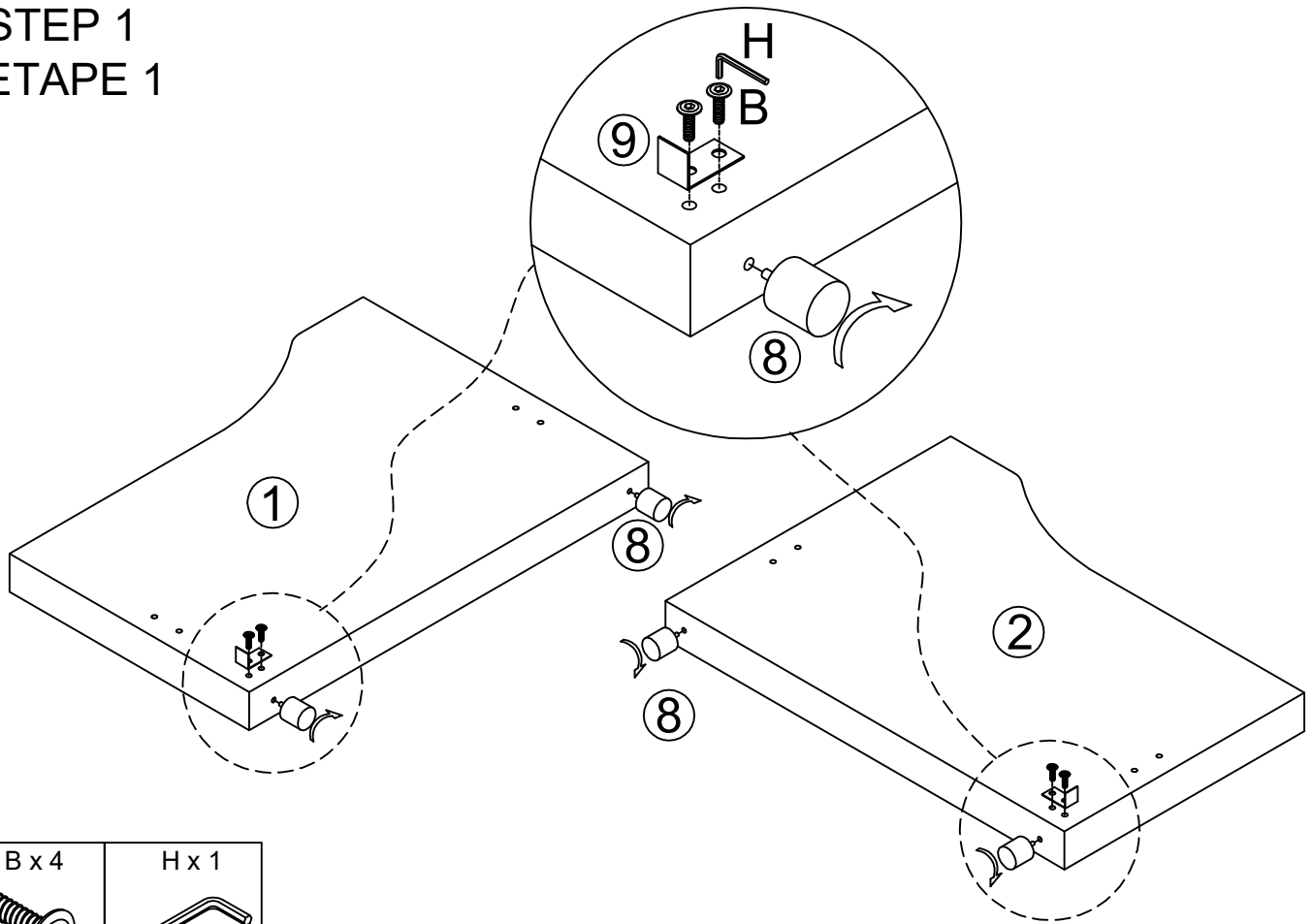

STEP 2
ETAPE 2

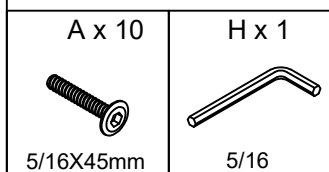
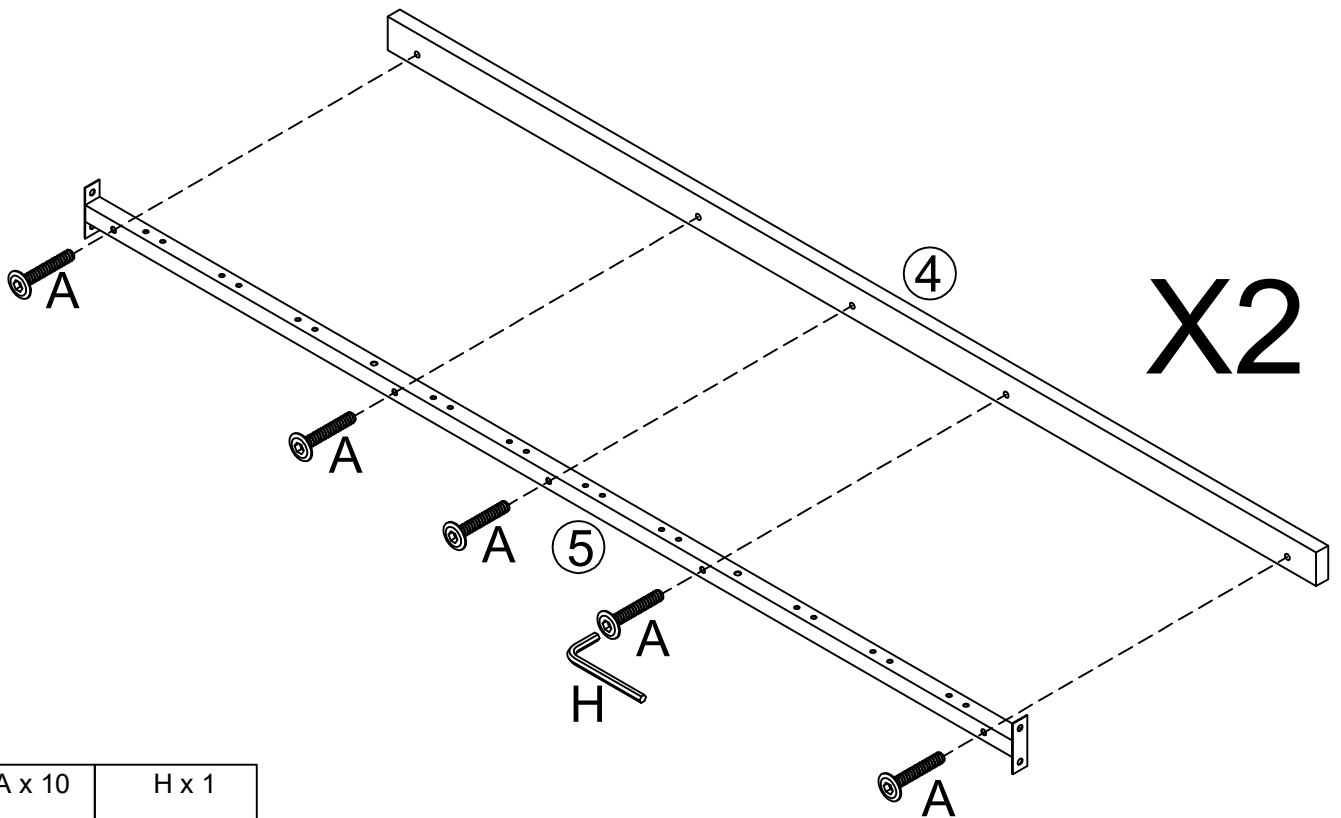

STEP 3
ETAPE 3

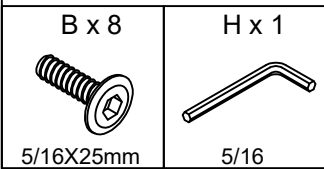
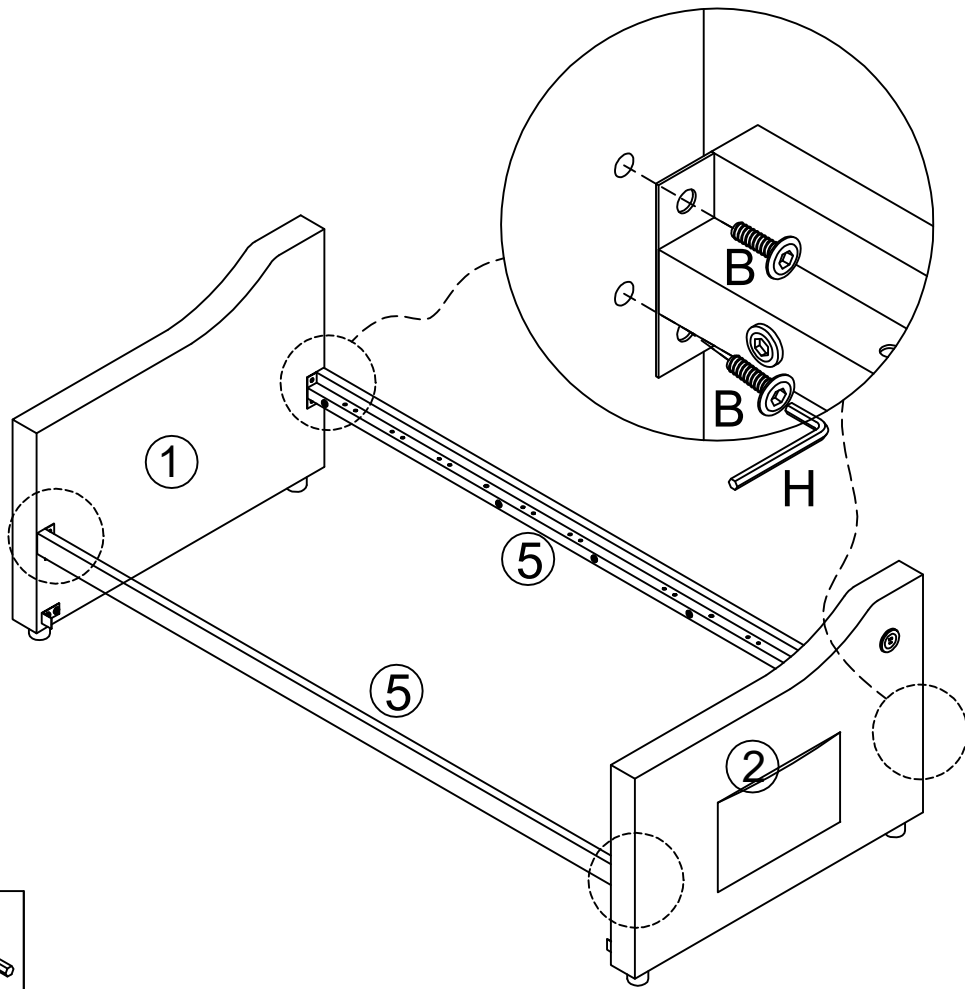

STEP 4
ETAPE 4

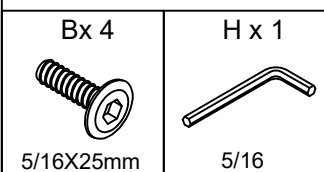
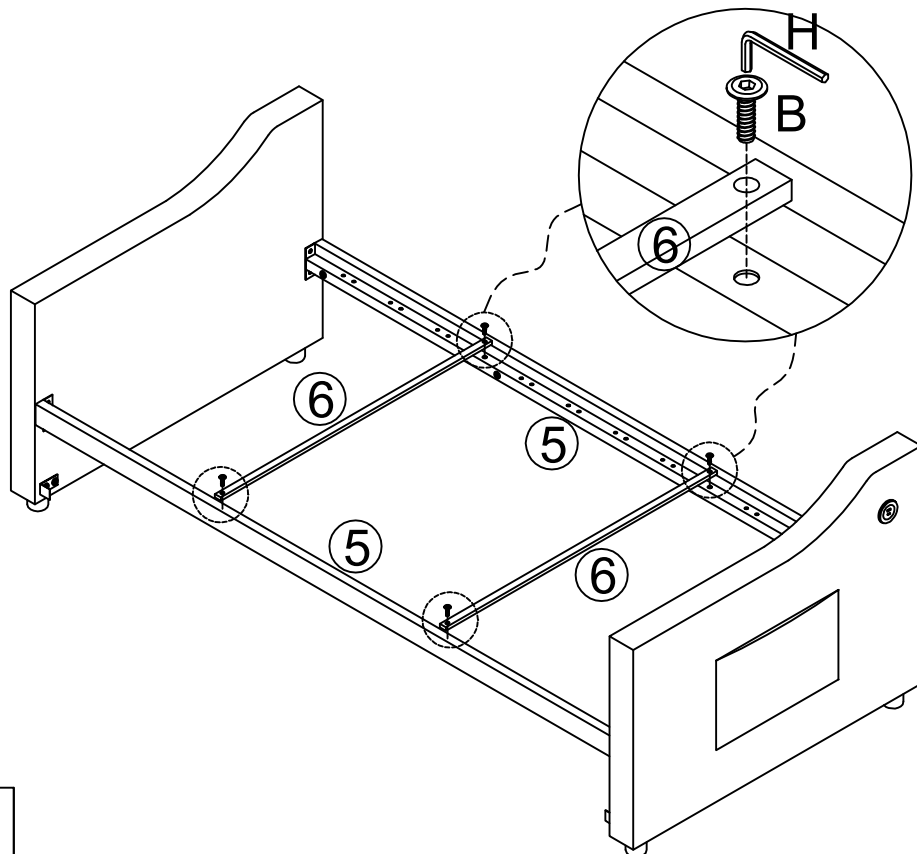

STEP 5
ETAPE 5

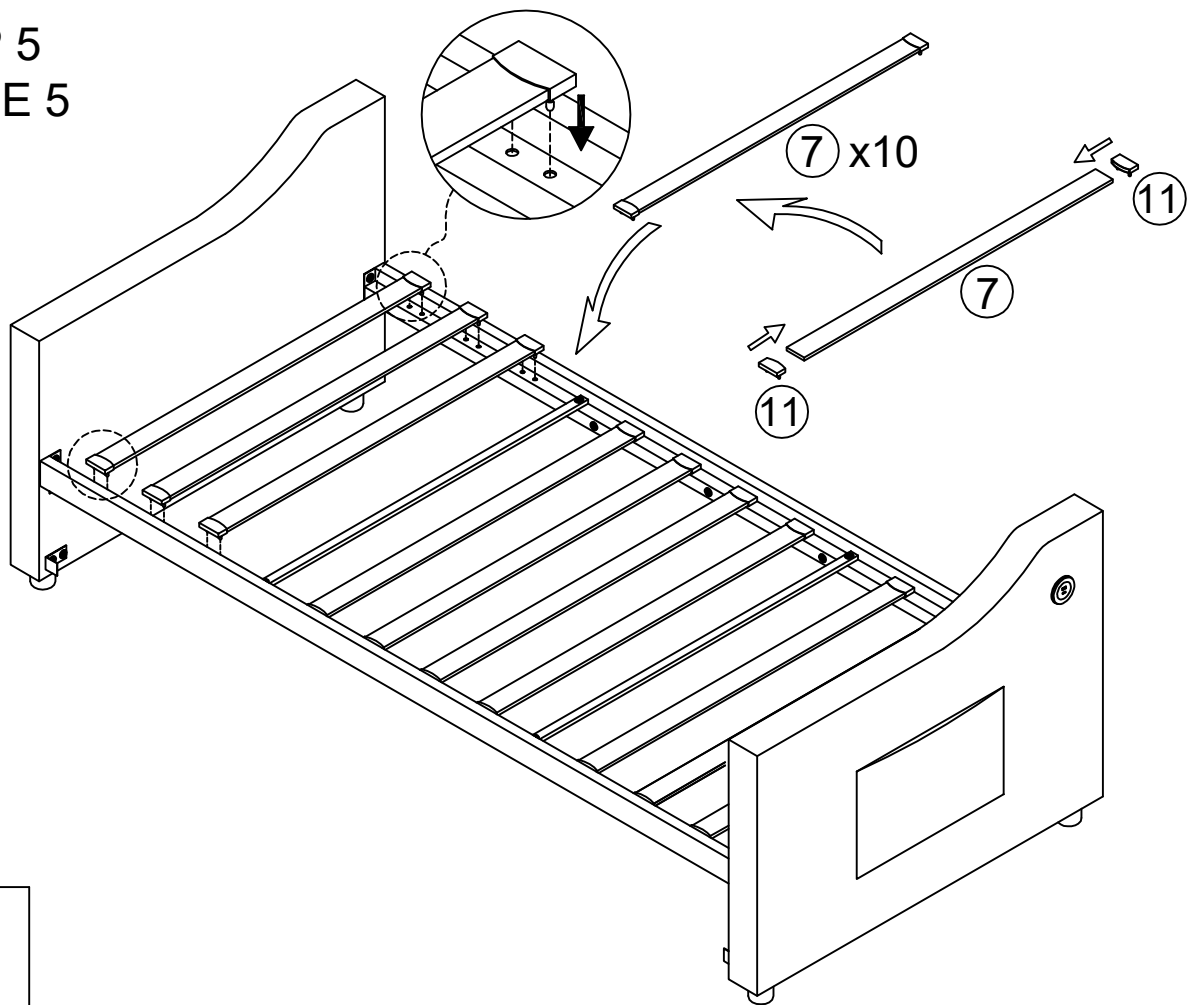

(11) x20

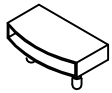

STEP 6
ETAPE 6

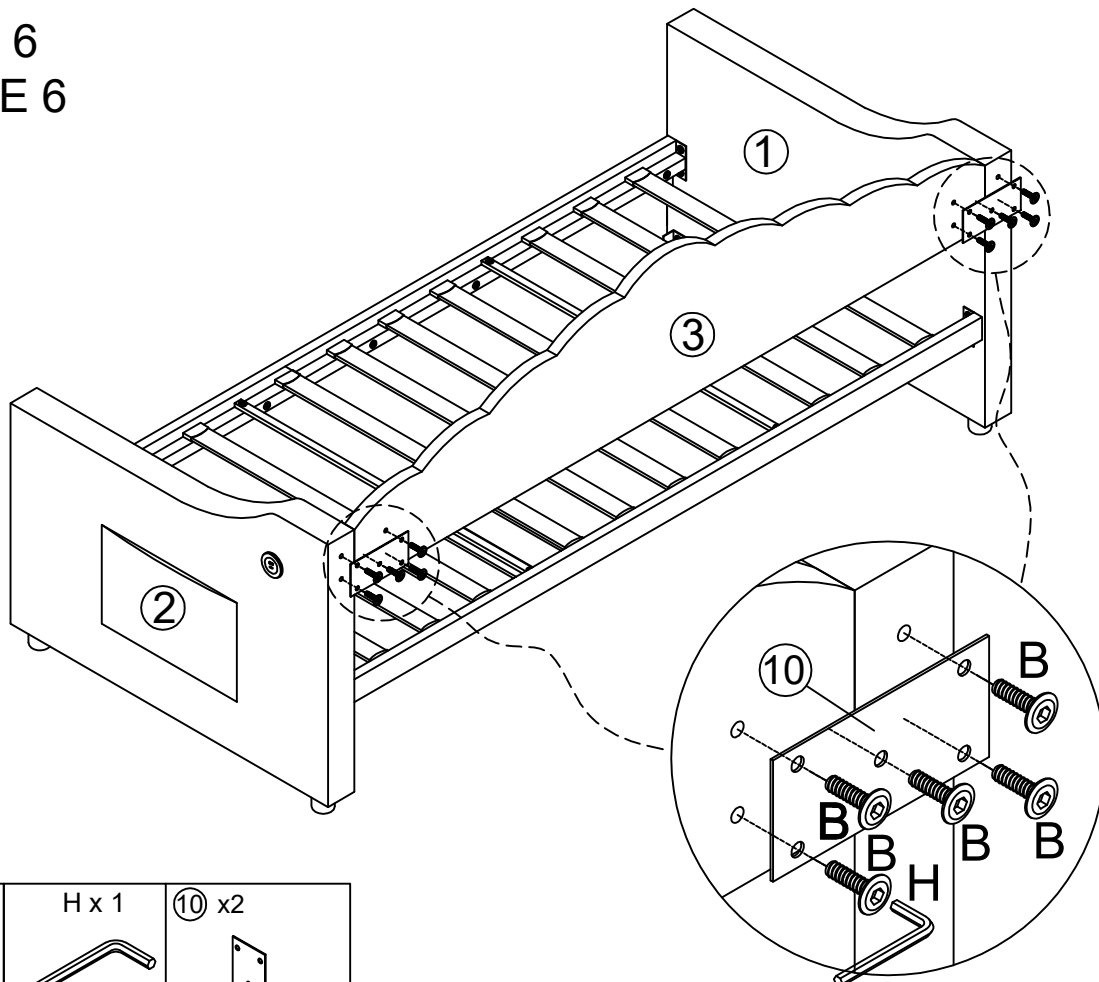

B x 10



5/16 X 25mm

H x 1





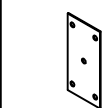

5/16

(10) x 2

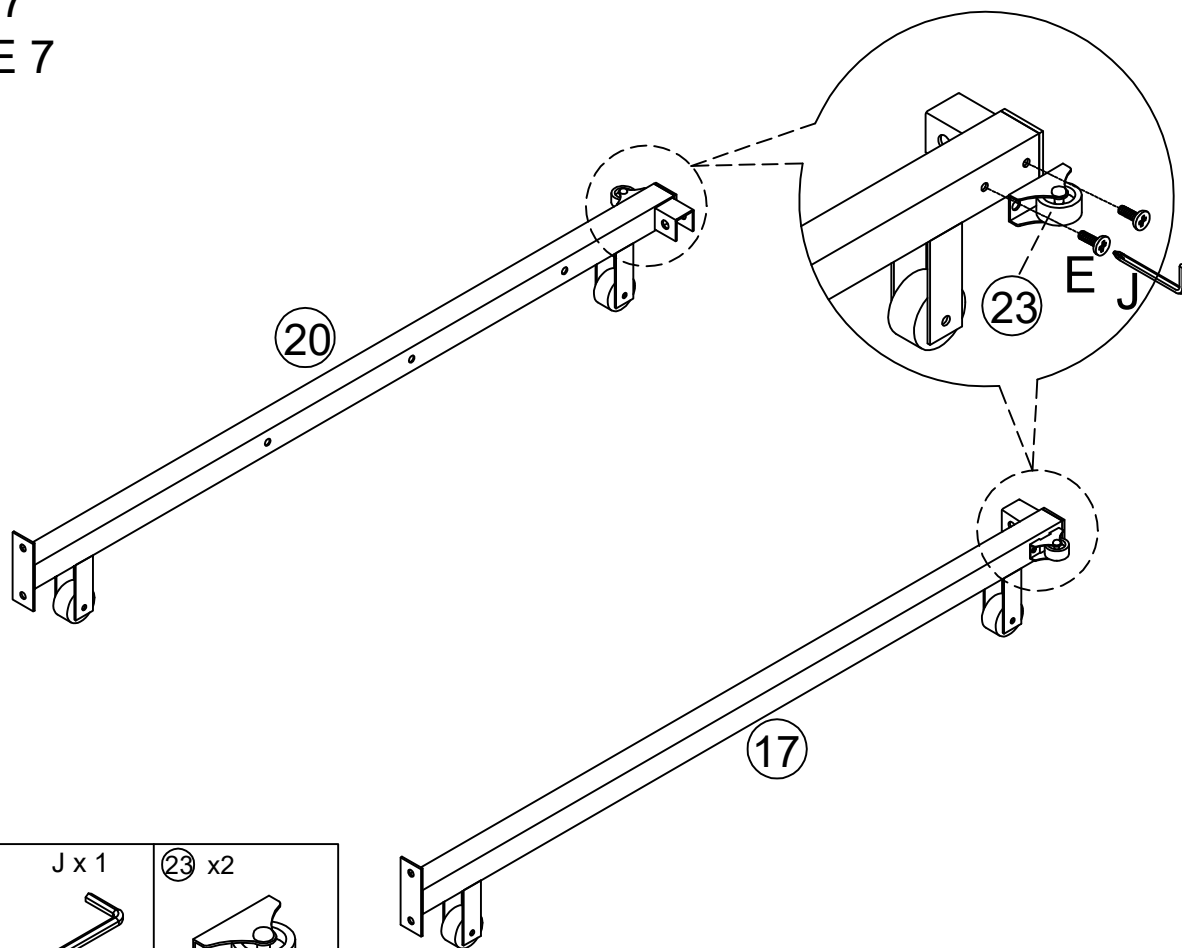



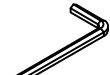



STEP 7 ETAPE 7

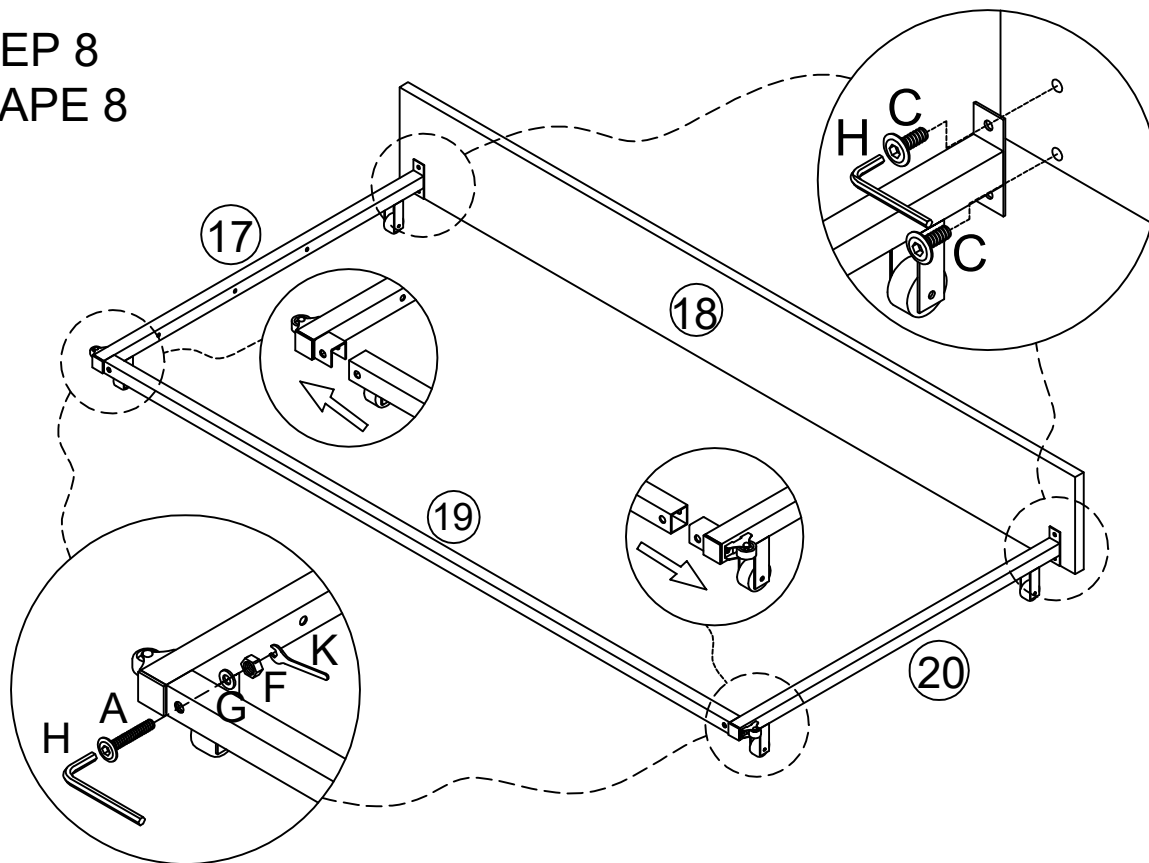

Ex 4	J x 1	23 x 2
		
M4X15mm	1/4	



STEP 8 ETAPE 8



A x 2	Cx 4	F x 2	Gx 2	H x 1	K x 1
					
5/16X45mm	5/16X15mm	5/16	Ø19X5/16	5/16	

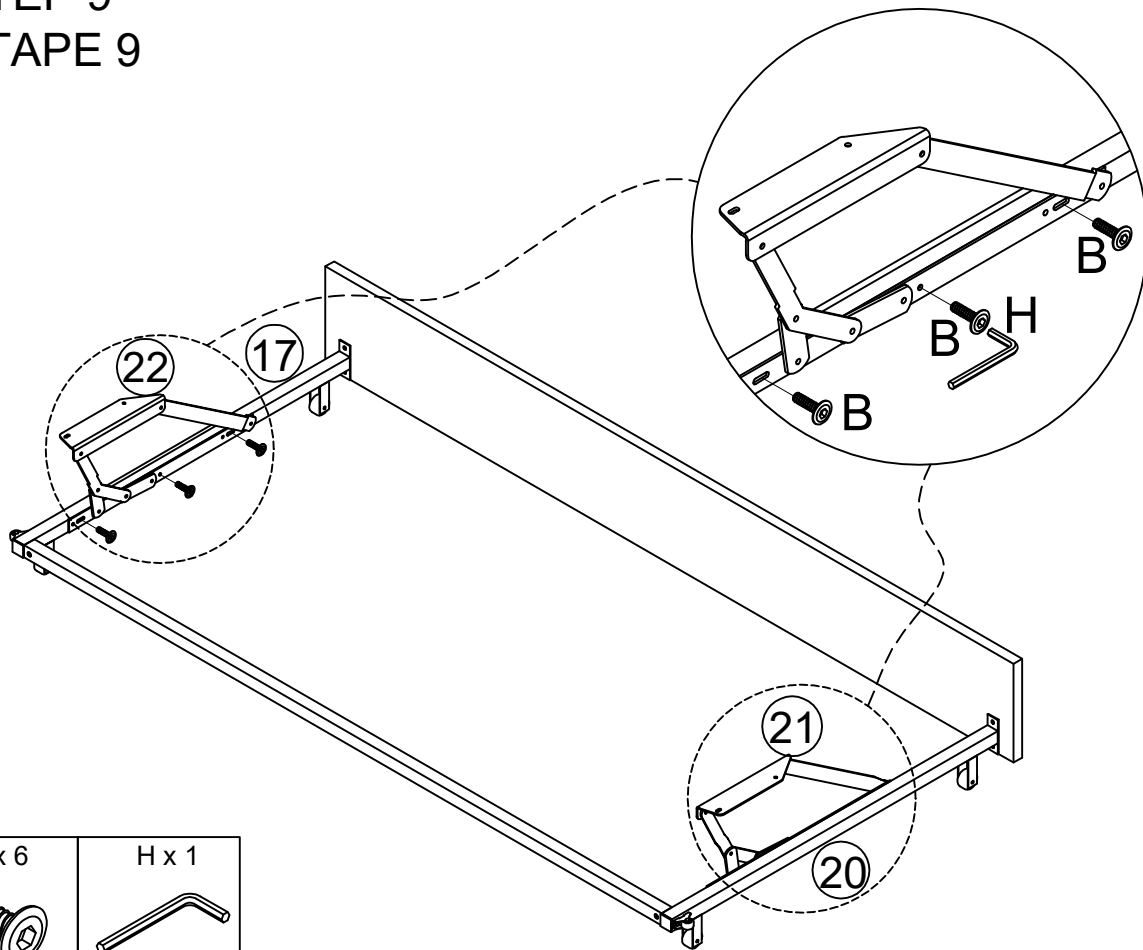

STEP 9
ETAPE 9



B x 6	H x 1
	
5/16X25mm	5/16

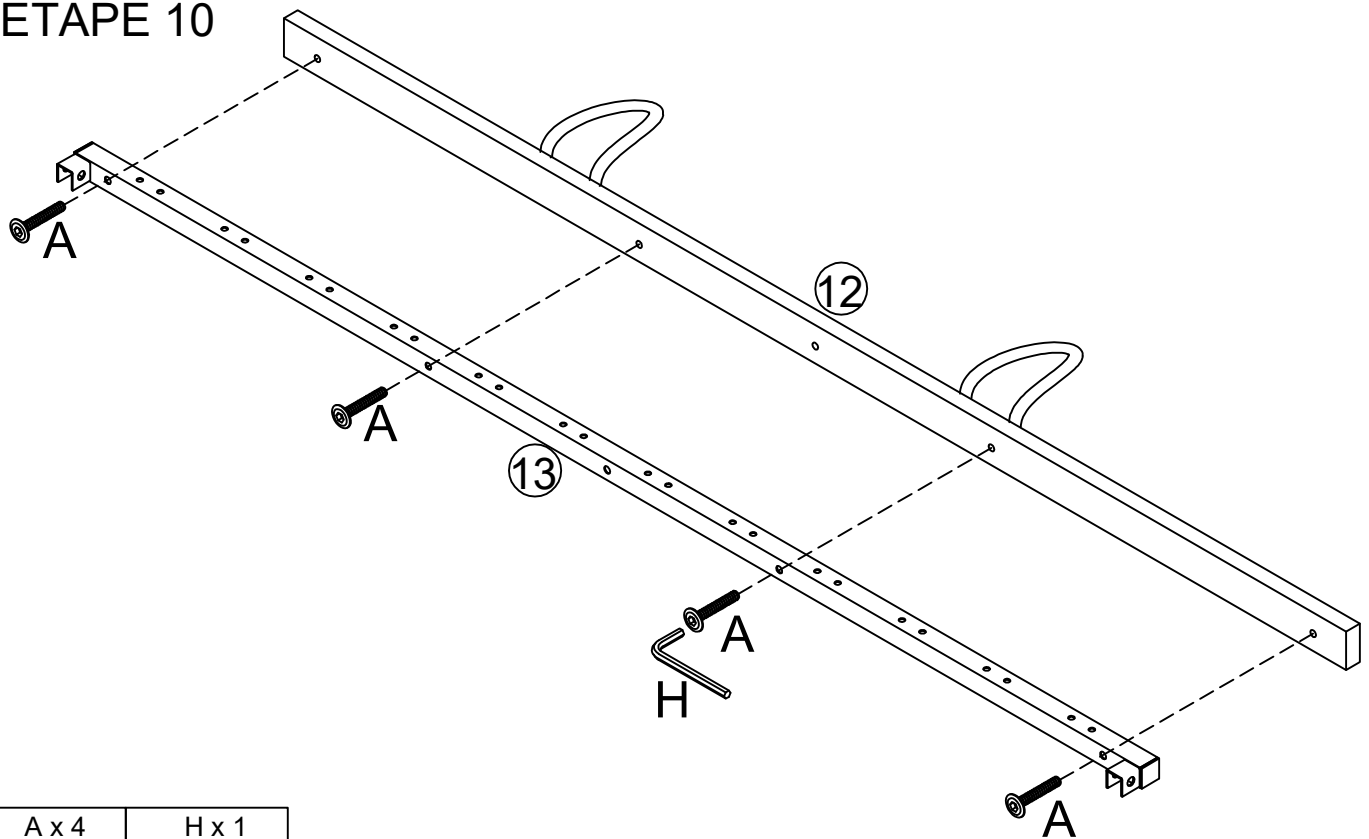



STEP 10
ETAPE 10

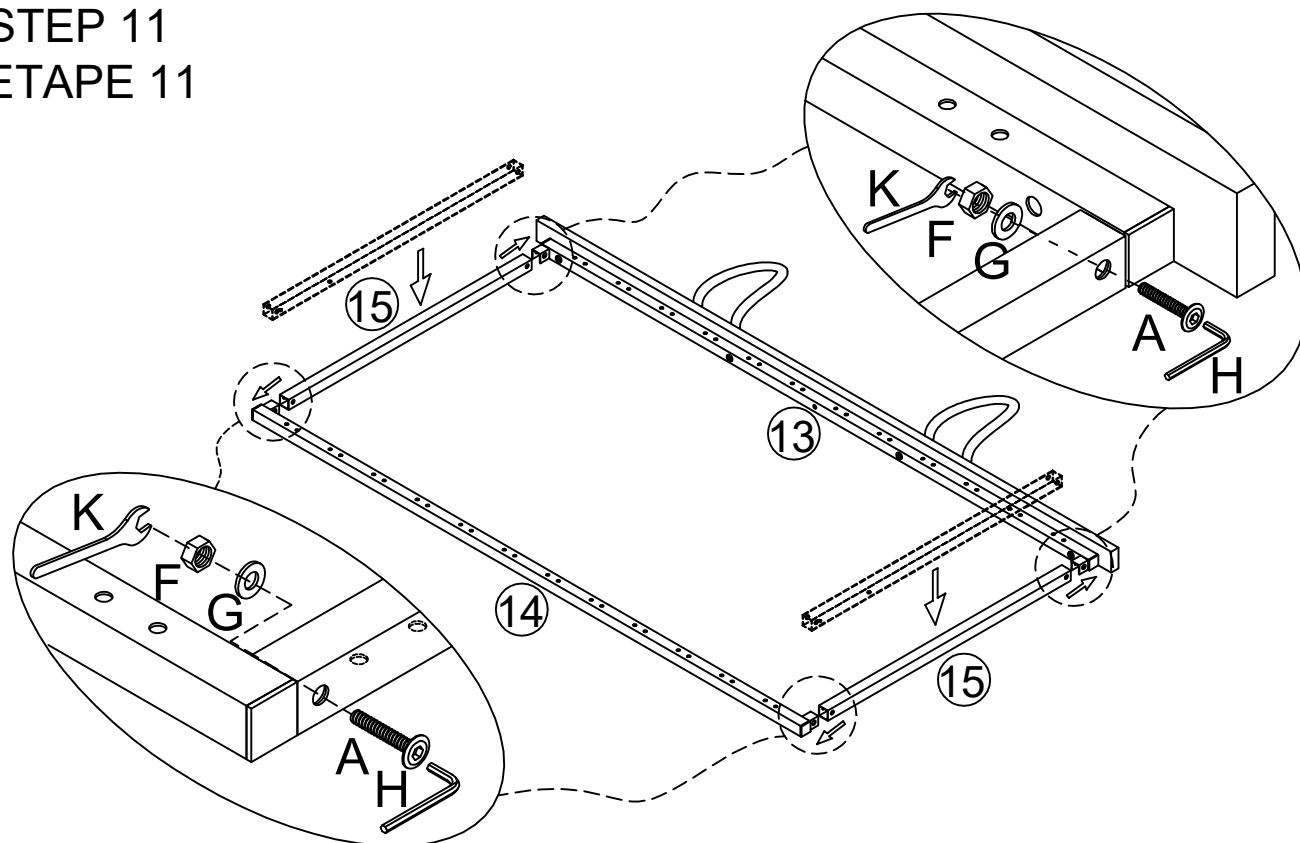

A x 4	H x 1
	
5/16X45mm	5/16



STEP 11 ETAPE 11



A x 4	F x 4	G x 4	H x 1	K x 1
				
5/16X45mm	5/16	Ø19X5/16	5/16	

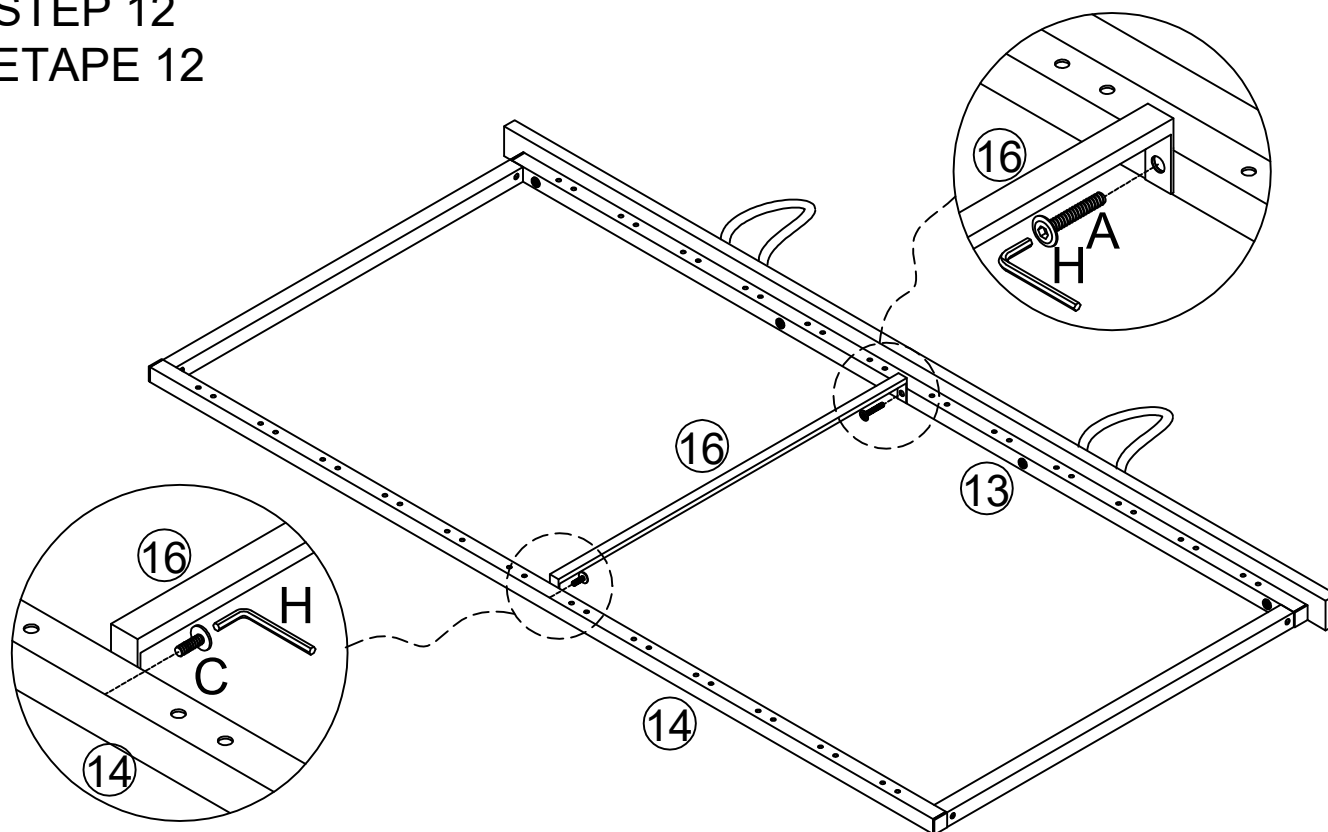

STEP 12 ETAPE 12

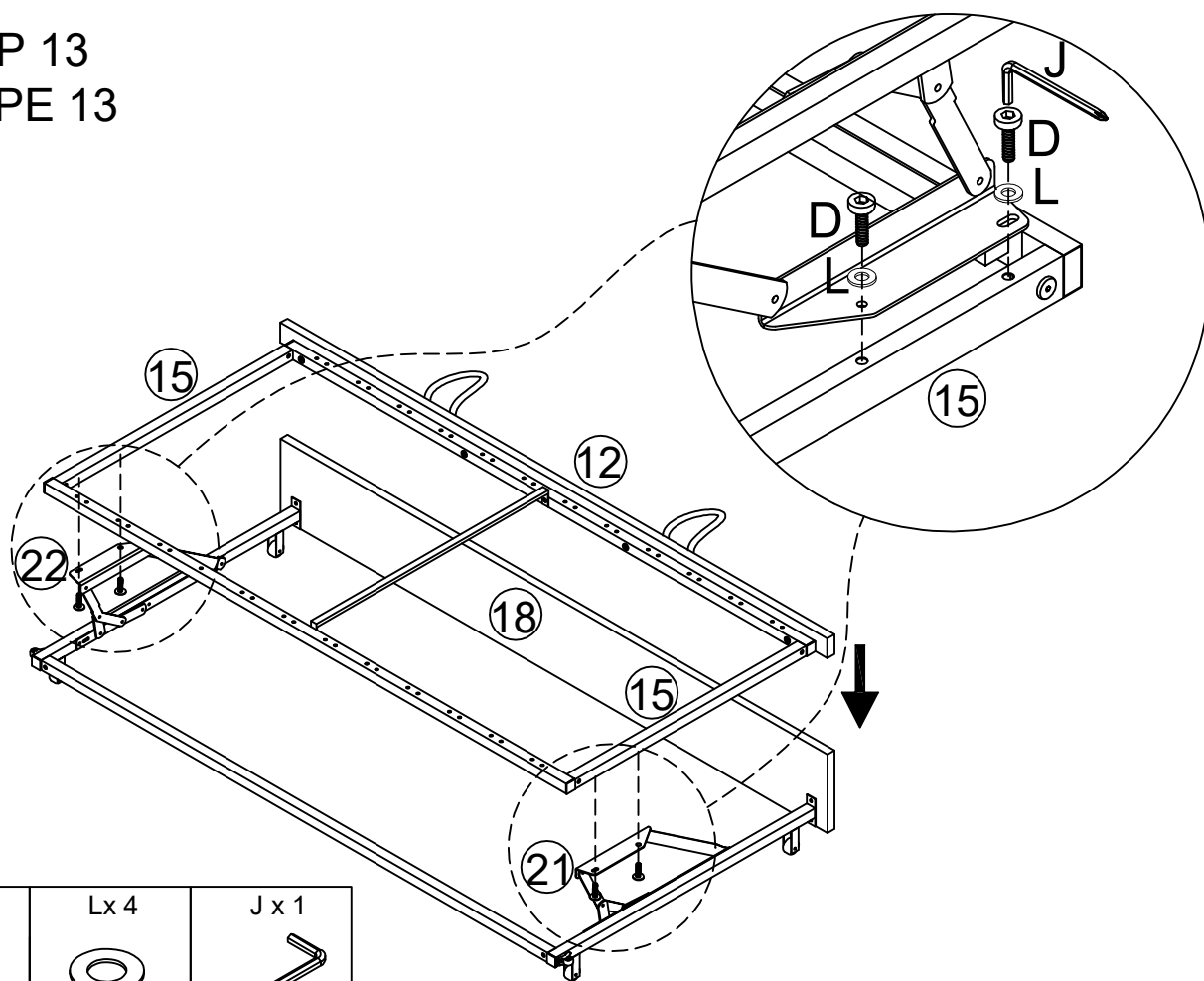

A x 1	Cx 1	H x 1
		
5/16X45mm	5/16X15mm	5/16

STEP 13
ETAPE 13



D x 4  1/4x25mm	L x 4  Ø16x1/4	J x 1  1/4
--	---	--

STEP 14
ETAPE 14

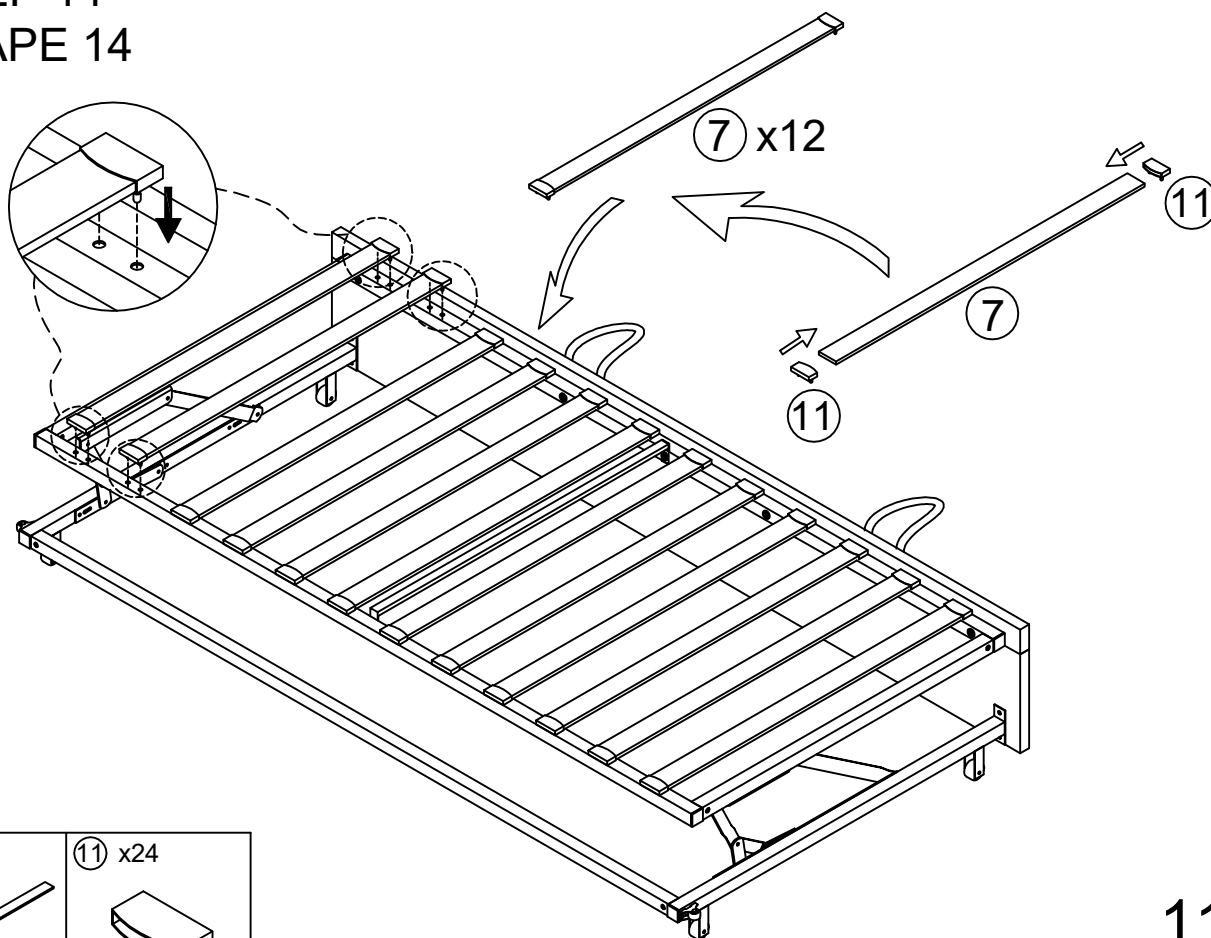

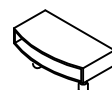
⑦ x 12 	⑪ x 24 
--	---

STEP 15
ETAPE 15

