

# ASSEMBLY INSTRUCTION

N652P239970 / N652P239971

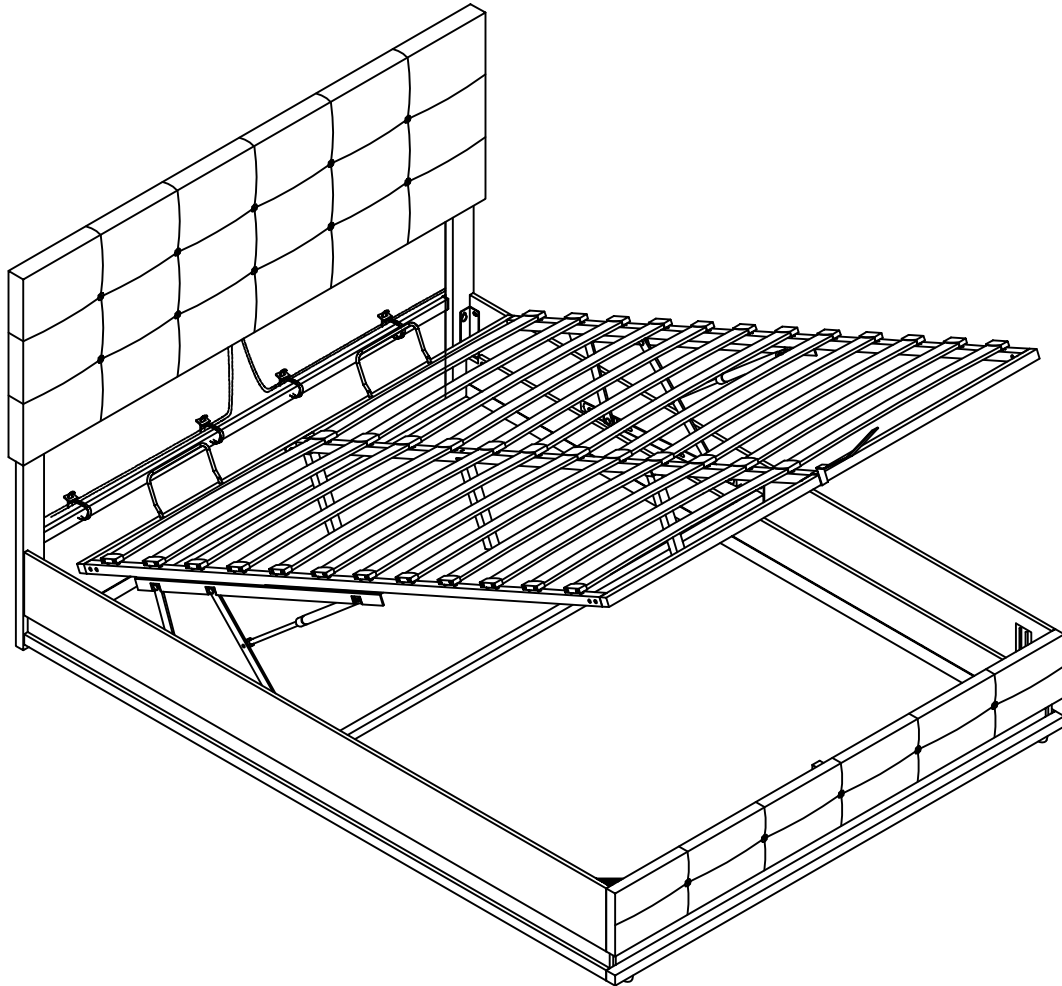

## TIPS

1. This product is divided into 2 parcels for delivery. They may not arrive at the same time. Please wait patiently.
2. Please read the instructions fully before assembly. These instructions include important information which could ensure correct assembly. We have been working on providing high quality products for you. However, in the rare instance that your product is defective, missing parts or there are some issues, please don't hesitate to contact our customer service to submit parts requirements, assembly suggestion, or warranty claims, and we will give the best solution as soon as possible. If necessary, we need you to provide some more clear pictures of the issue.
3. Insert the screws in holes and tighten the screws, but not too tight, 70%~80% is ok, finally tighten all the screws. If some issues happened that some screws can not target to the hole or some parts are difficult to install, please adjust the tightness of the screws.
4. 2 people are recommended to finish.

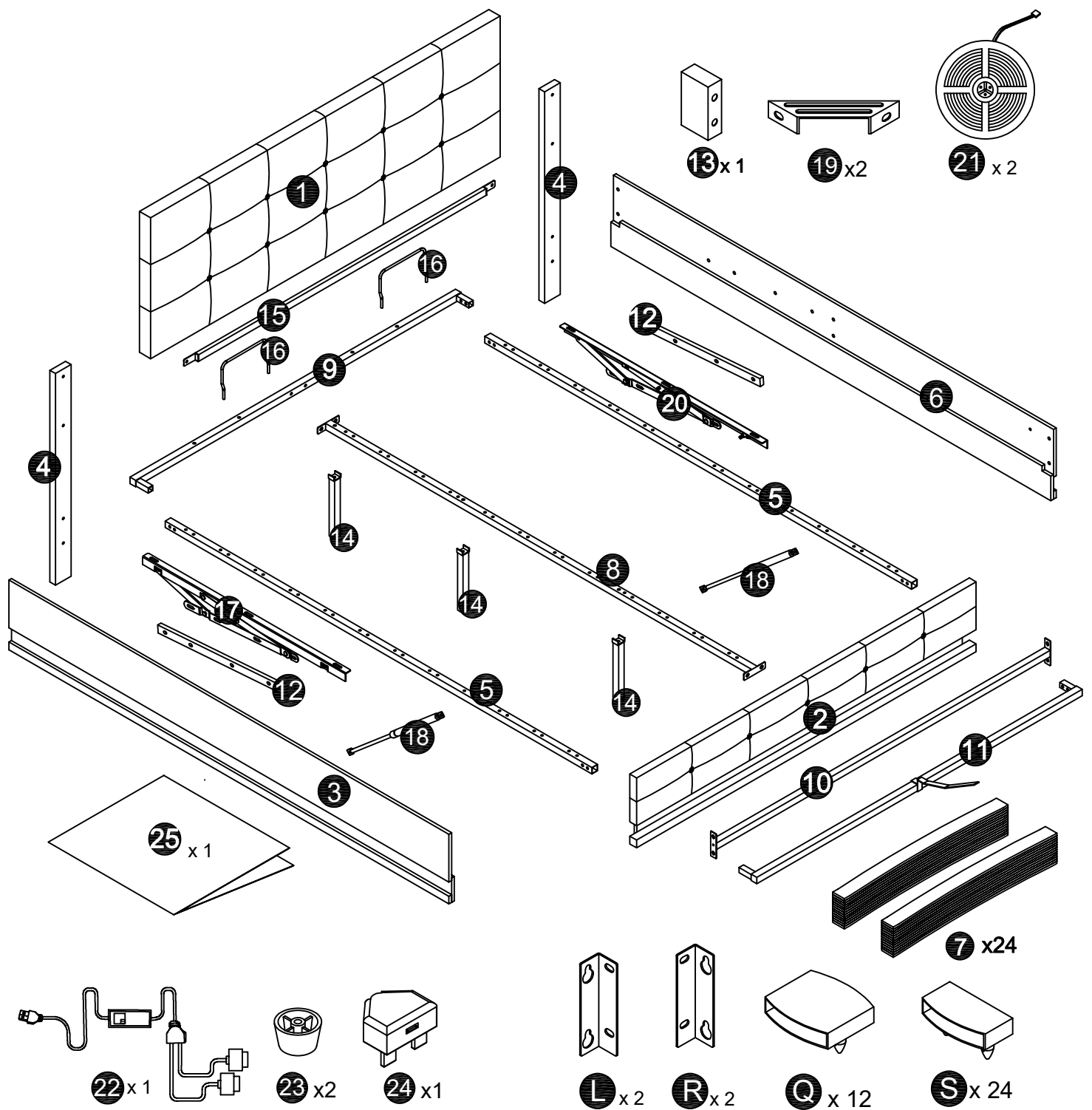

LED light strip electronic accessories list

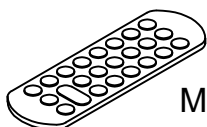

Remote control

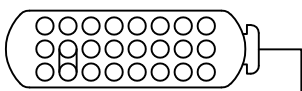

Unplug the battery separator of the remote control before use

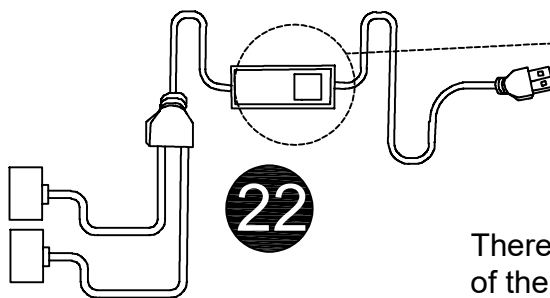

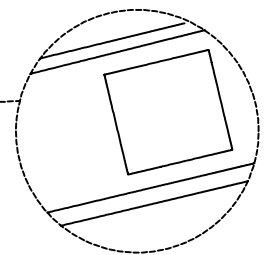

power cord



There is a QR code at this position of the power cord, which can be scanned to download the APP and operate the LED light strip.



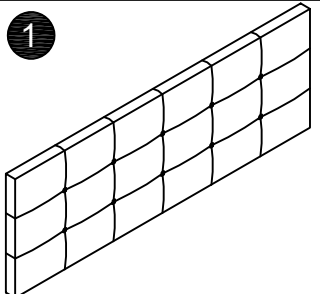
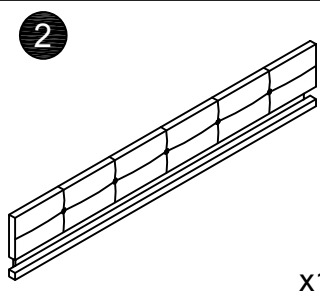

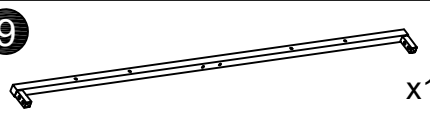
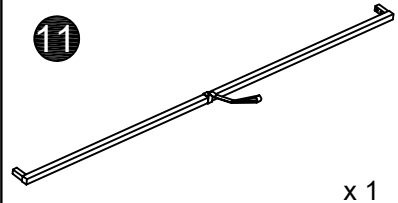
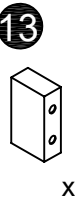
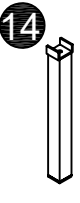
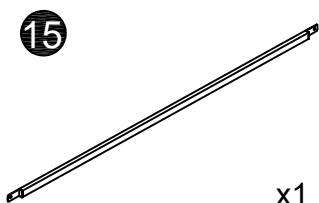
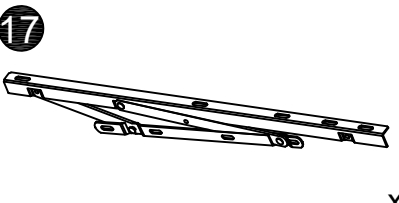
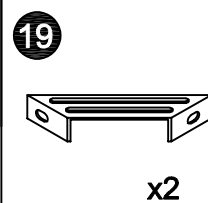
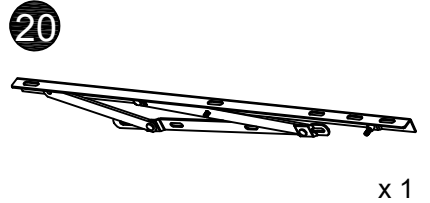
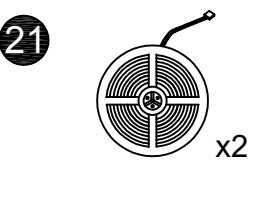
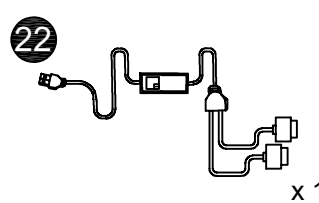
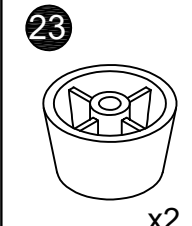
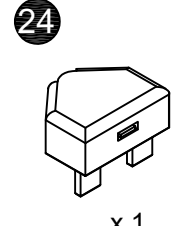
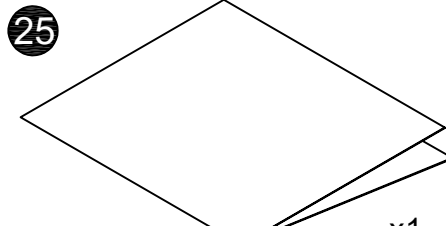
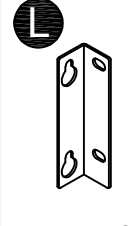
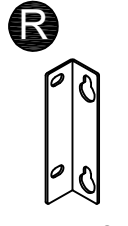



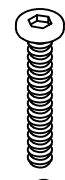
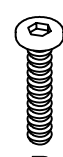
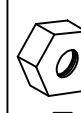

# Part list

N652P239970

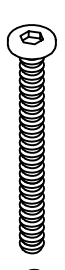
 1 x1	 2 x1	 4 x2	 9 x1	
 11 x1	 13 x1	 14 x3	 15 x1	 17 x1
 19 x2	 20 x1	 21 x2	 22 x1	
 23 x2	 24 x1	 25 x1	 L x2	 R x2

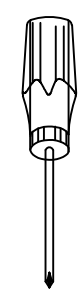
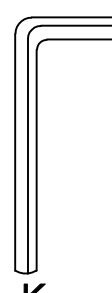
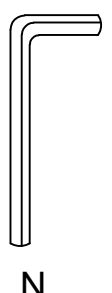
# Hardware list

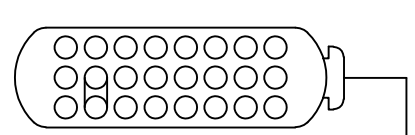
N652P239970

 A M8x14 x 30	 B M8x25 x 10	 C M8x45 x 7	 D M8x30 x 8	 E M8 x 4	 F x 4	 G M6x70 x 2	 H M6x14 x 2	 I M6x20 x 2	 J x 1	 K M8 x 1	 N M6 x 1	 O x 1
 T 4x30 x 2	 M Unplug the battery separator of the remote control before use x 1					 P x 4						

# Part list

N652P239971

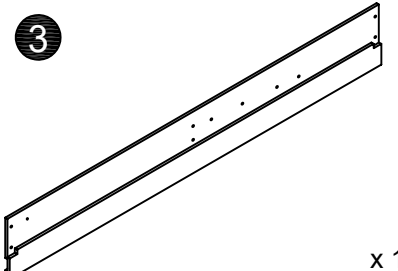
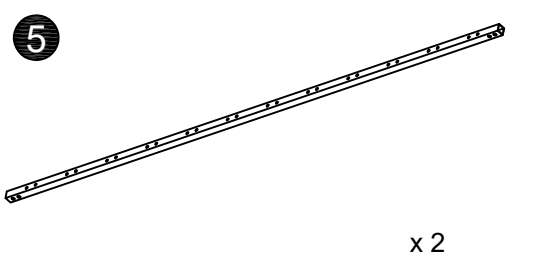
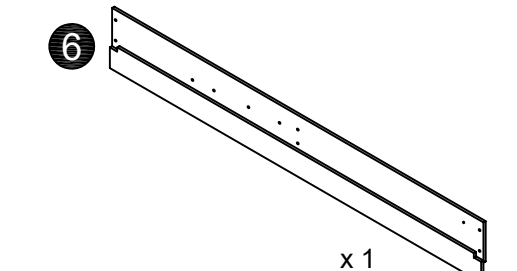
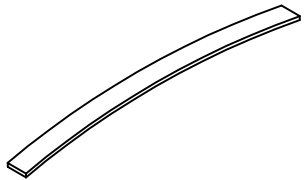
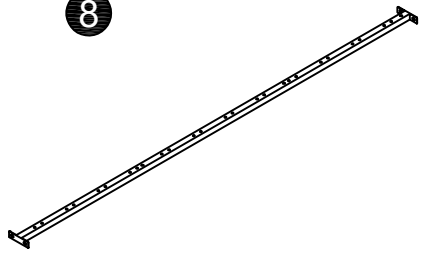
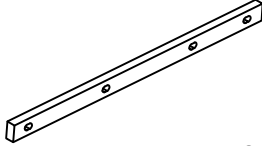
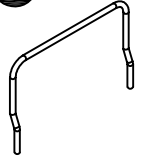
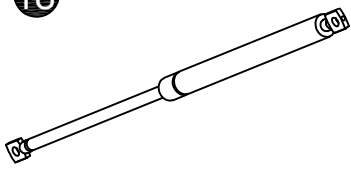
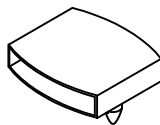
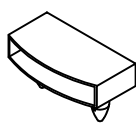
 <p>3</p> <p>x 1</p>	 <p>5</p> <p>x 2</p>	 <p>6</p> <p>x 1</p>	
 <p>7</p> <p>x24</p>	 <p>8</p>	 <p>12</p> <p>x 2</p>	 <p>16</p> <p>x 2</p>
 <p>18</p> <p>x 2</p>	 <p>Q</p> <p>x 12</p>	 <p>S</p> <p>x 24</p>	

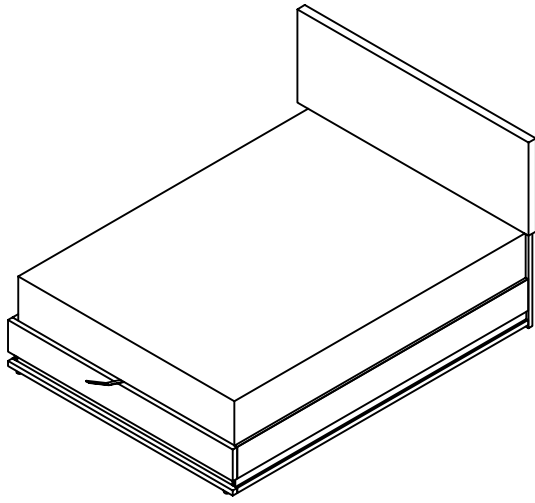

This product is not suitable for mattress recessed type.

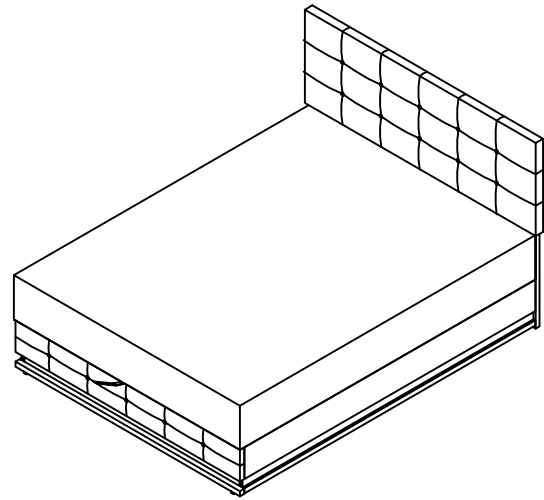

This product is suitable for placing mattresses on the top.

## IMPORTANT NOTICE OTTOMAN OPERATING INSTRUCTIONS

Once your bed frame is completely assembled, the slat unit will not operate correctly unless a mattress is placed on the slat frame. Position the mattress on the slat frame whilst it is in the closed position.

**PLEASE NOTE** - It takes a lot of force to make the initial movement of the ottoman. This is a design feature of the product so that it does not fall shut-the nearer to being closed the ottoman is, the easier it is to move. When the ottoman is almost shut, it will close completely under its own weight.

When lowering the slat unit for the first time, take care to make sure it does not rub unevenly on the inside face of the side rails. If it does, the bed has been assembled slightly out of square. This can be rectified by moving the foot end of the bed slightly to the left or right whilst leaving the headend stationary.

## PISTONS

The pistons used in the construction of this product are extremely strong and cannot be operated by hand when taken off the ottoman. All pistons are tested for correct pressure and operation before being attached to the slat unit. Initially it might appear that the pistons are very stiff when opening and closing the ottoman.

### THIS IS PERFECTLY NORMAL

When fully assembled and the mattress is in position, please raise and lower the ottoman 4/5 times to ensure the gas piston are fully lubricated.

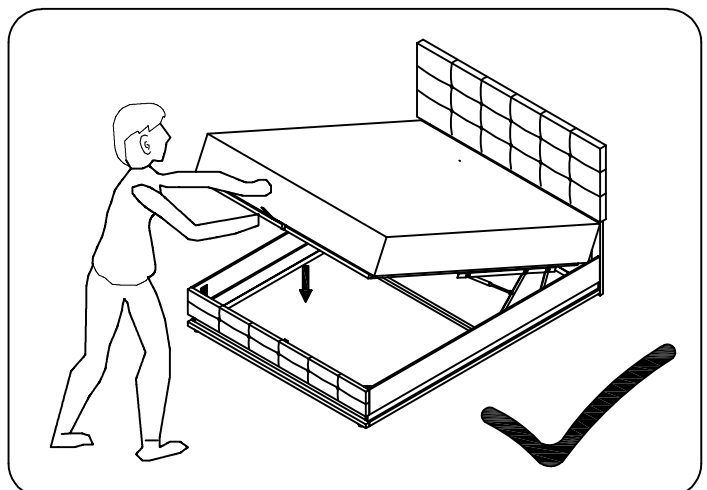
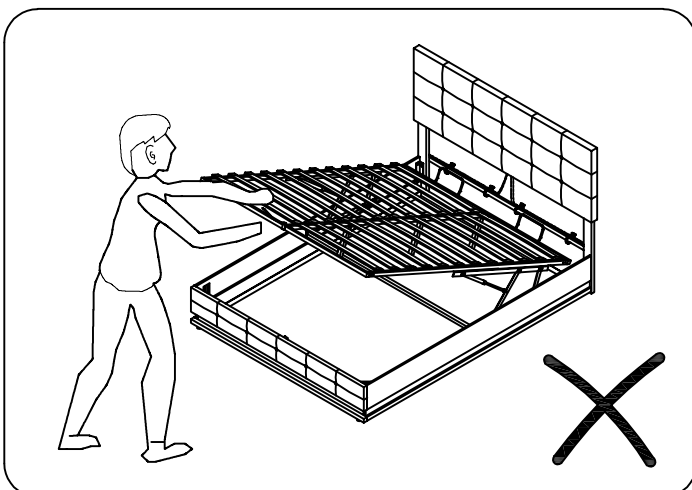

# Step 1:



x 4



x 4



x 1

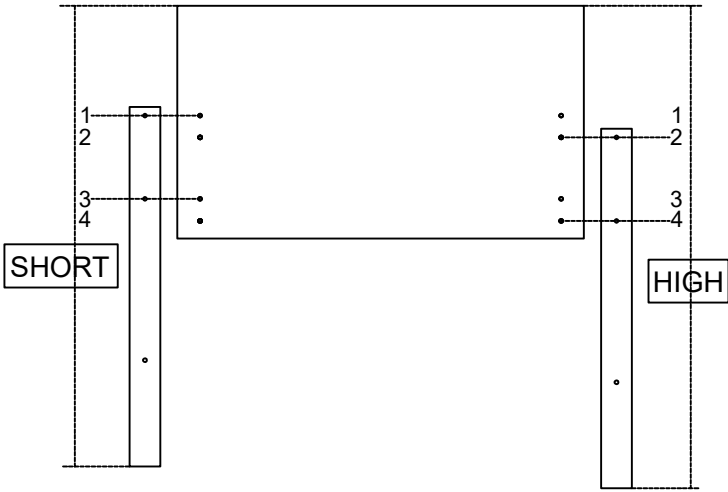
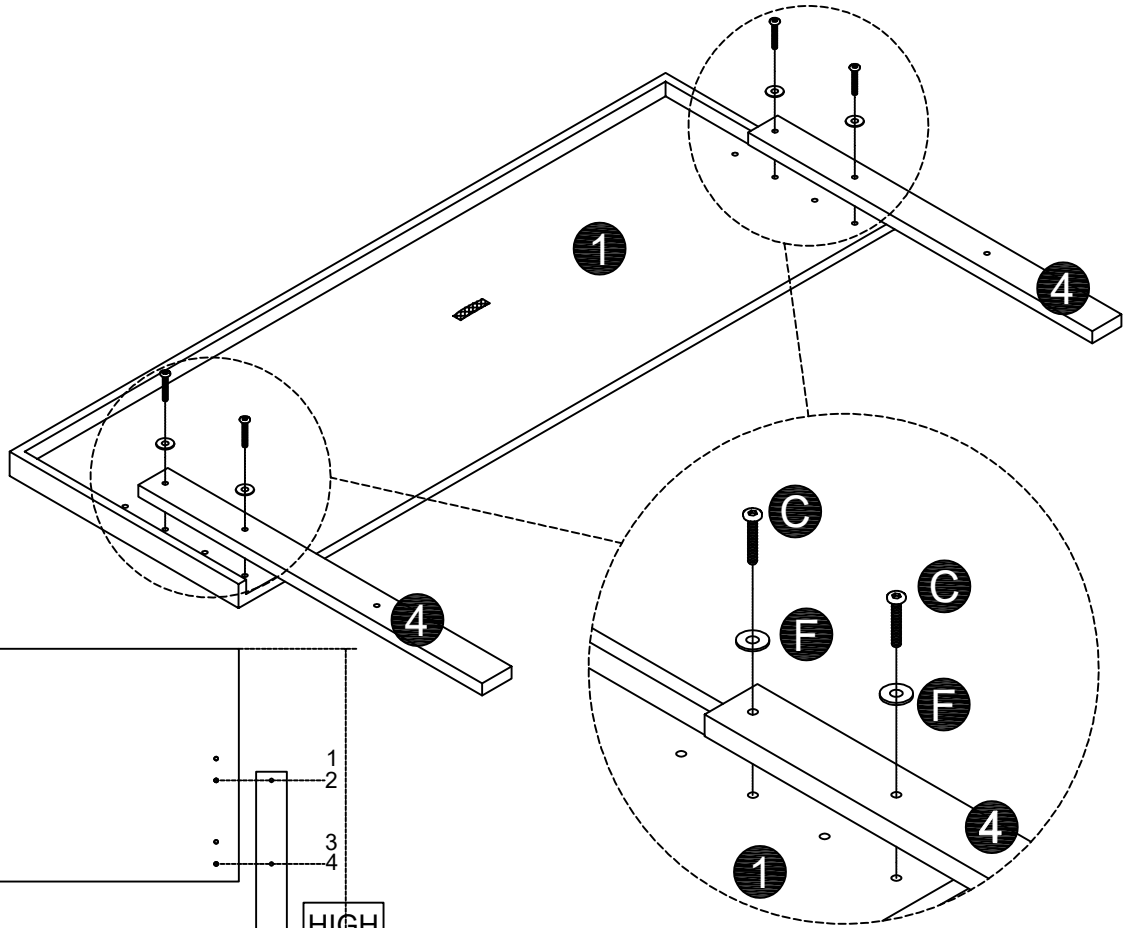

# Step 2:



x 2



x 1

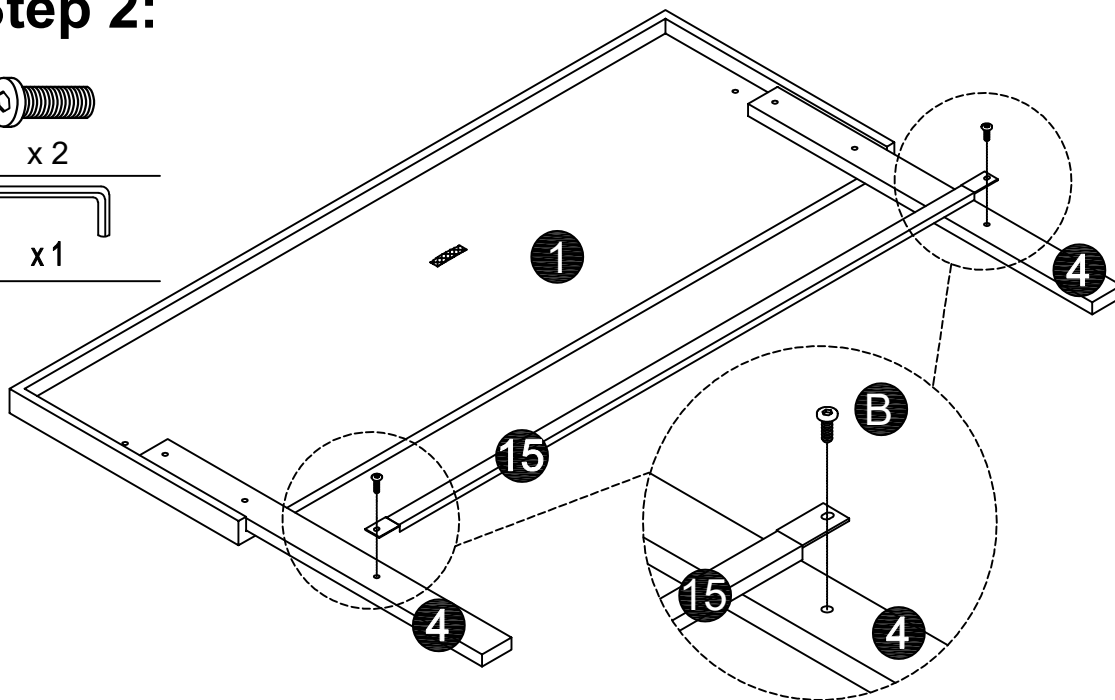

### Step 3:

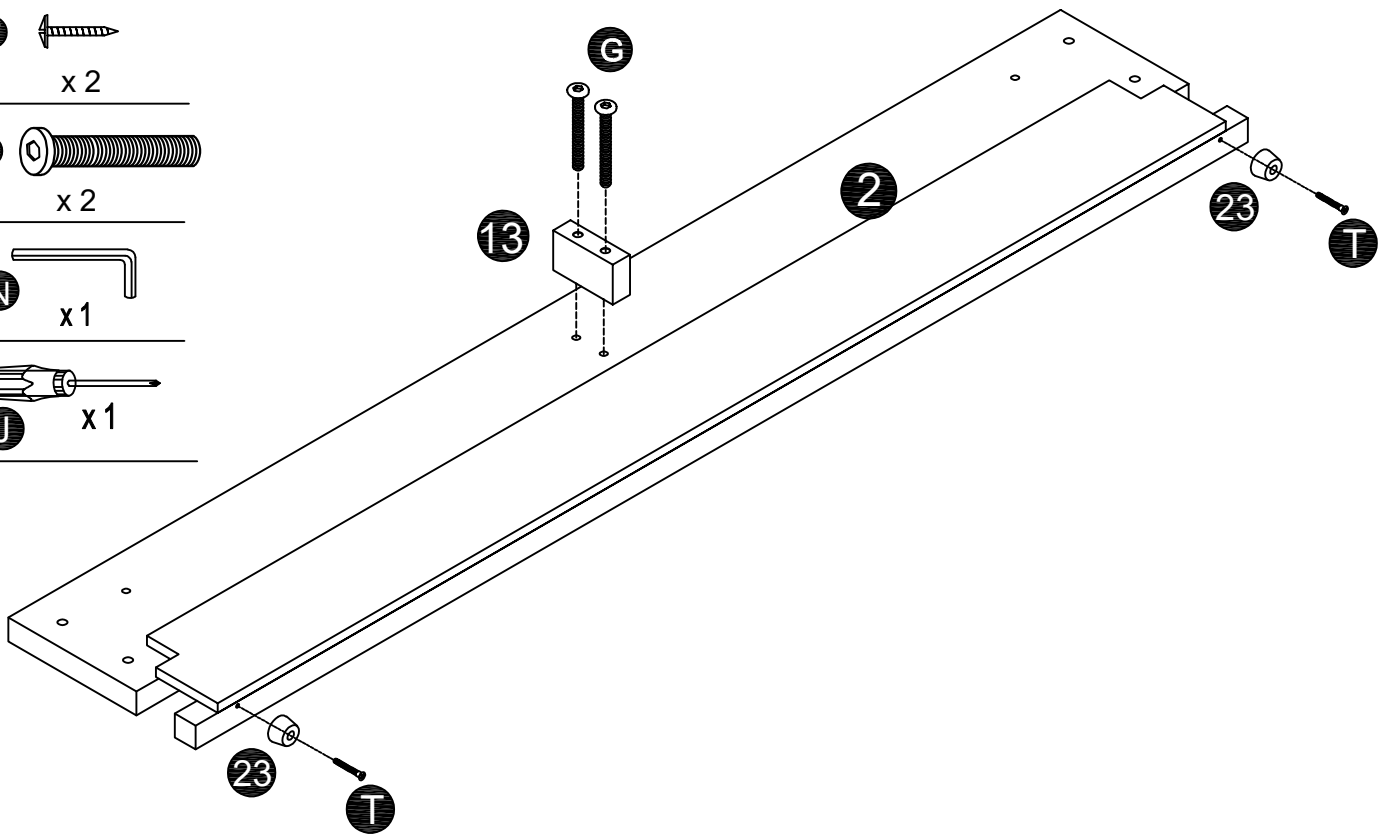
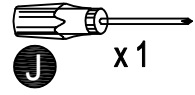
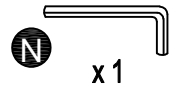
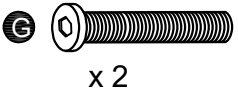
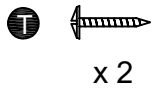

### Step 4:

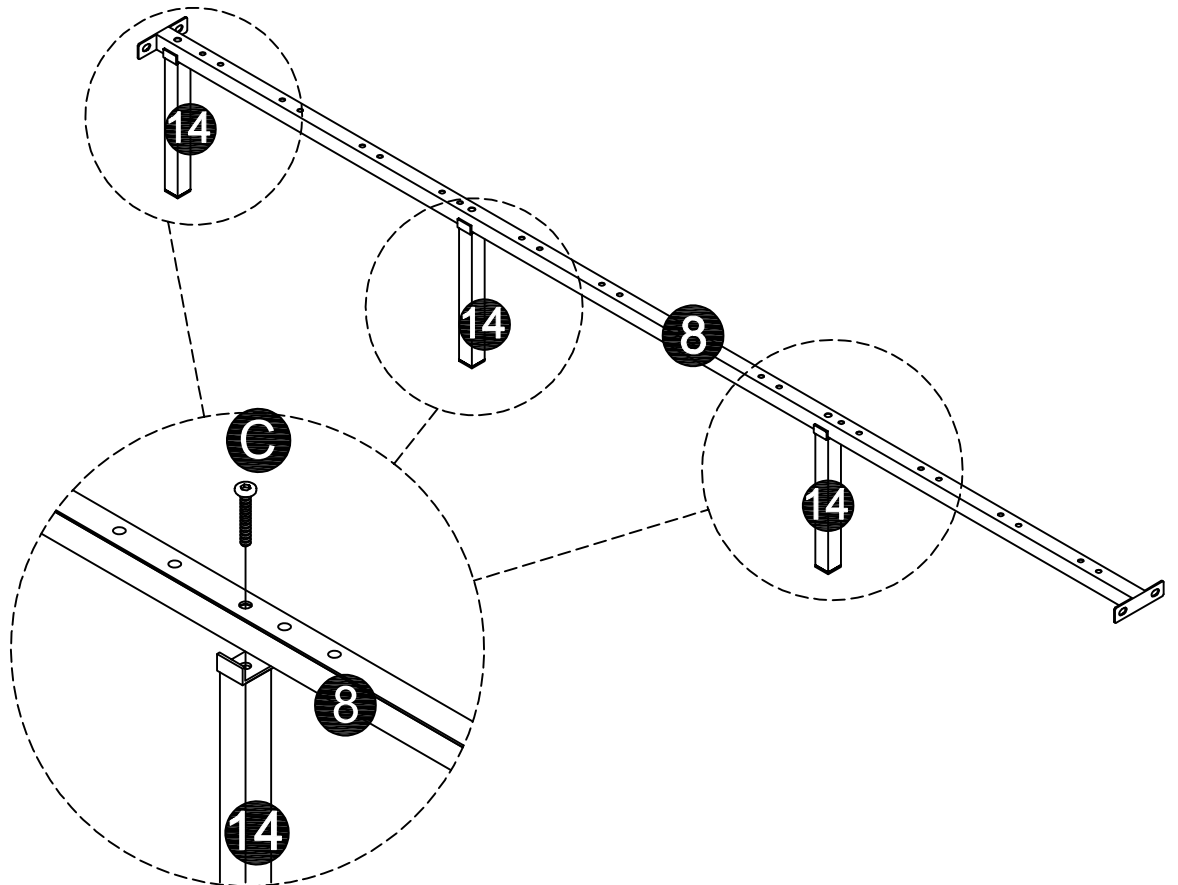
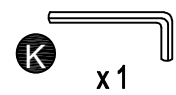
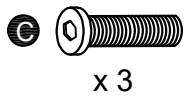

# Step 5:

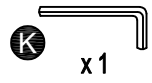
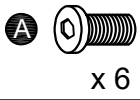

## Installation position diagram

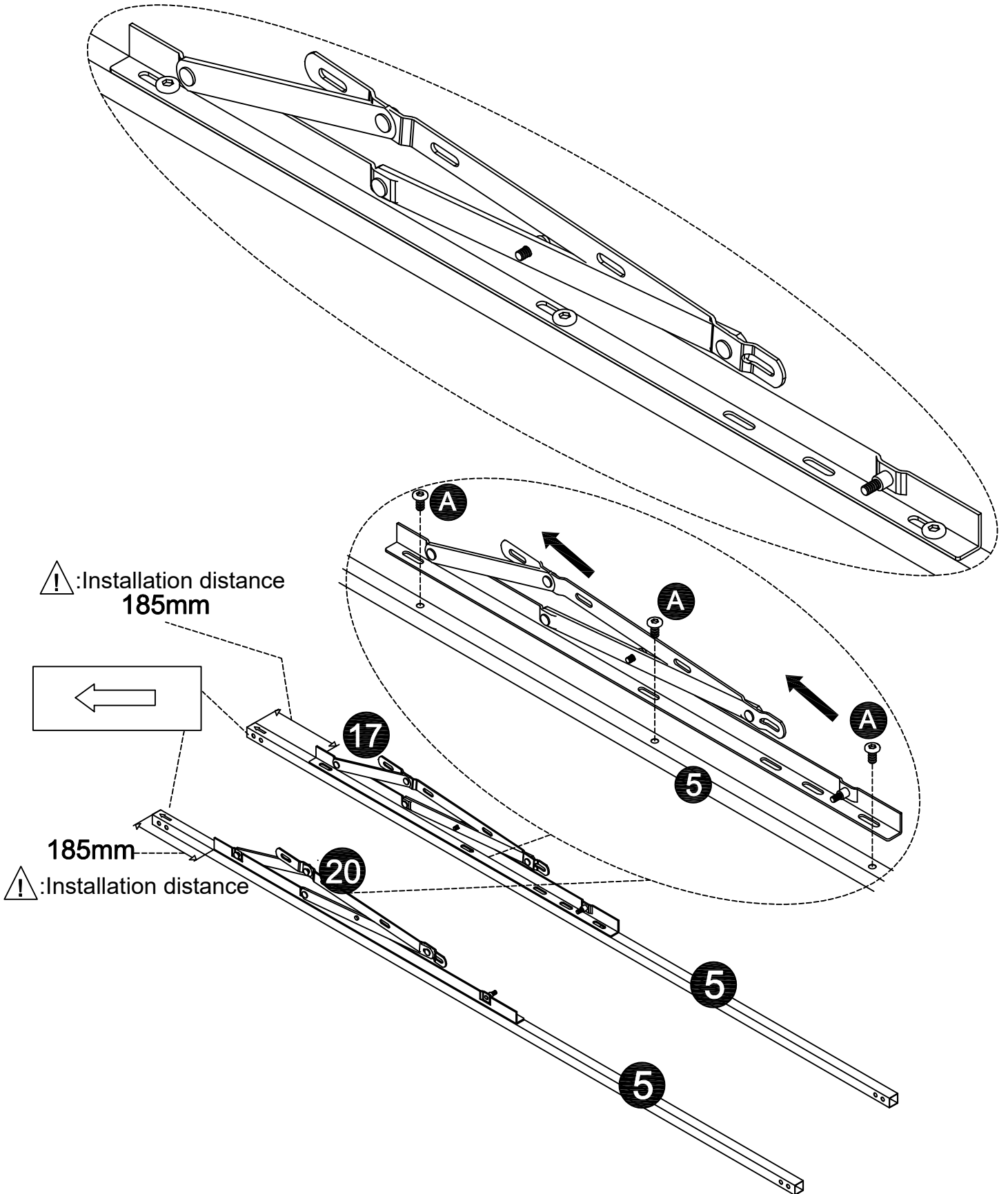

# Step 6:

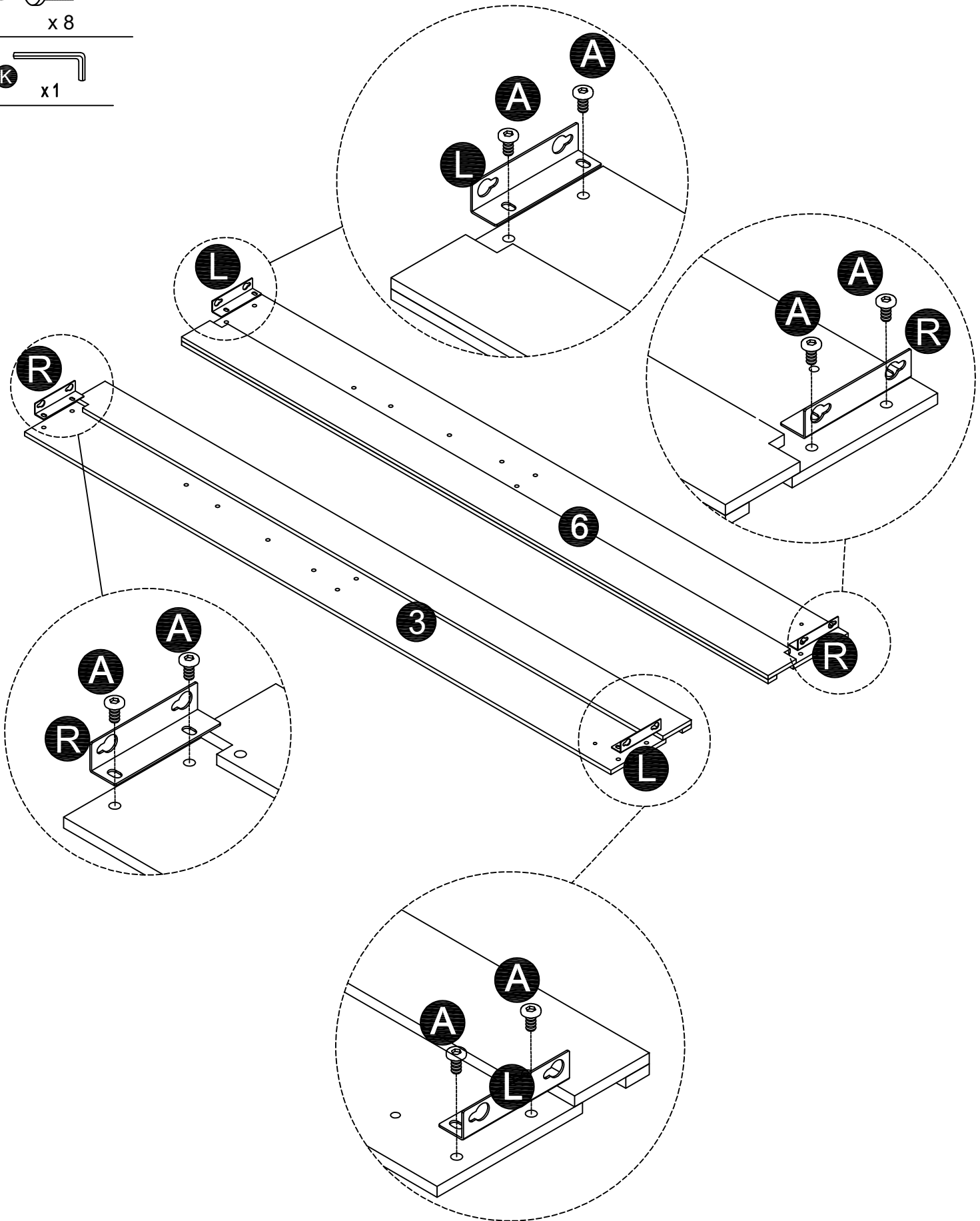
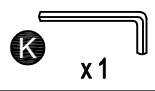
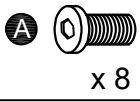

# Step 7:

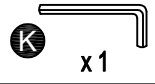
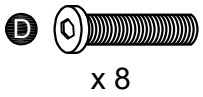

## Installation position diagram

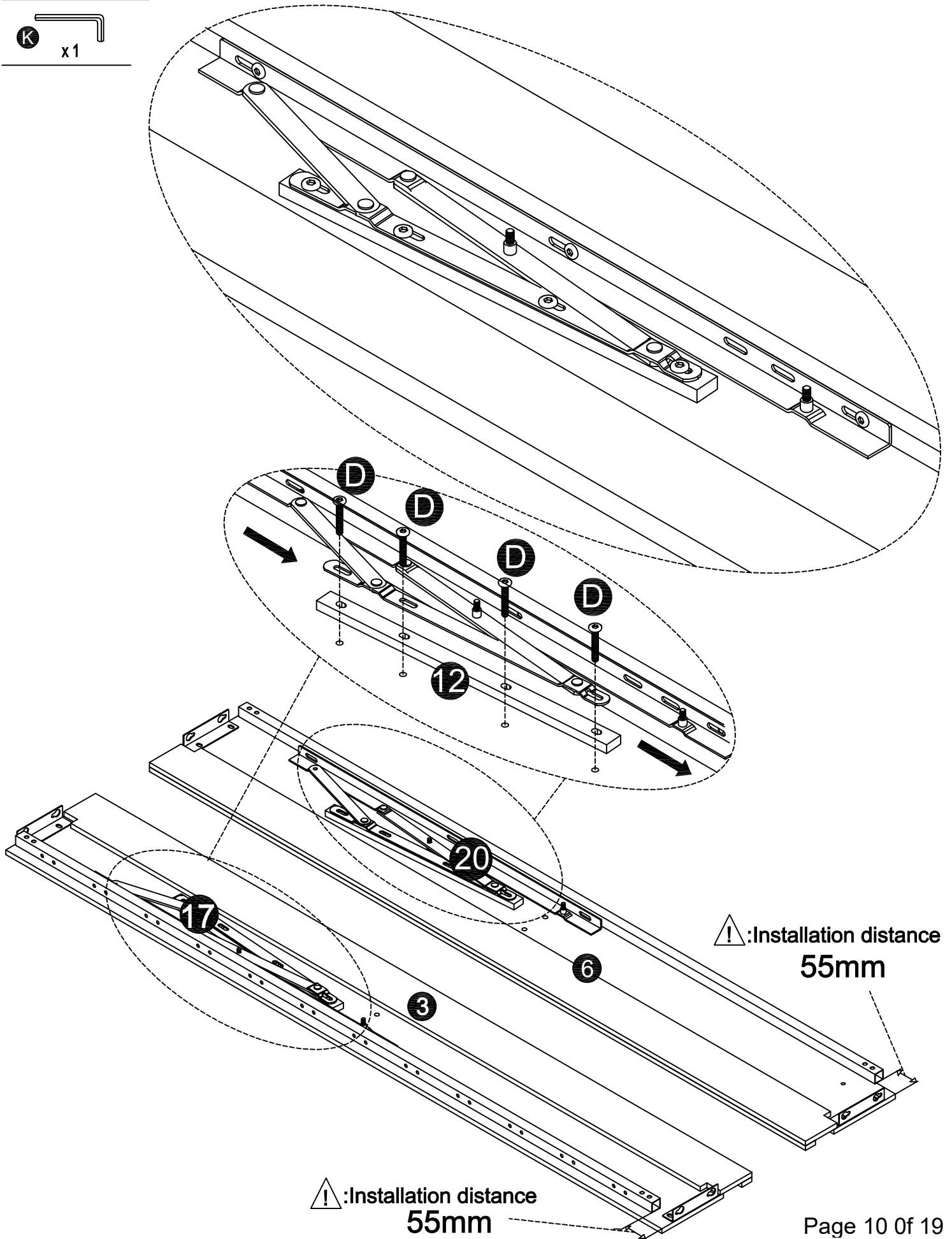

## Step 8:

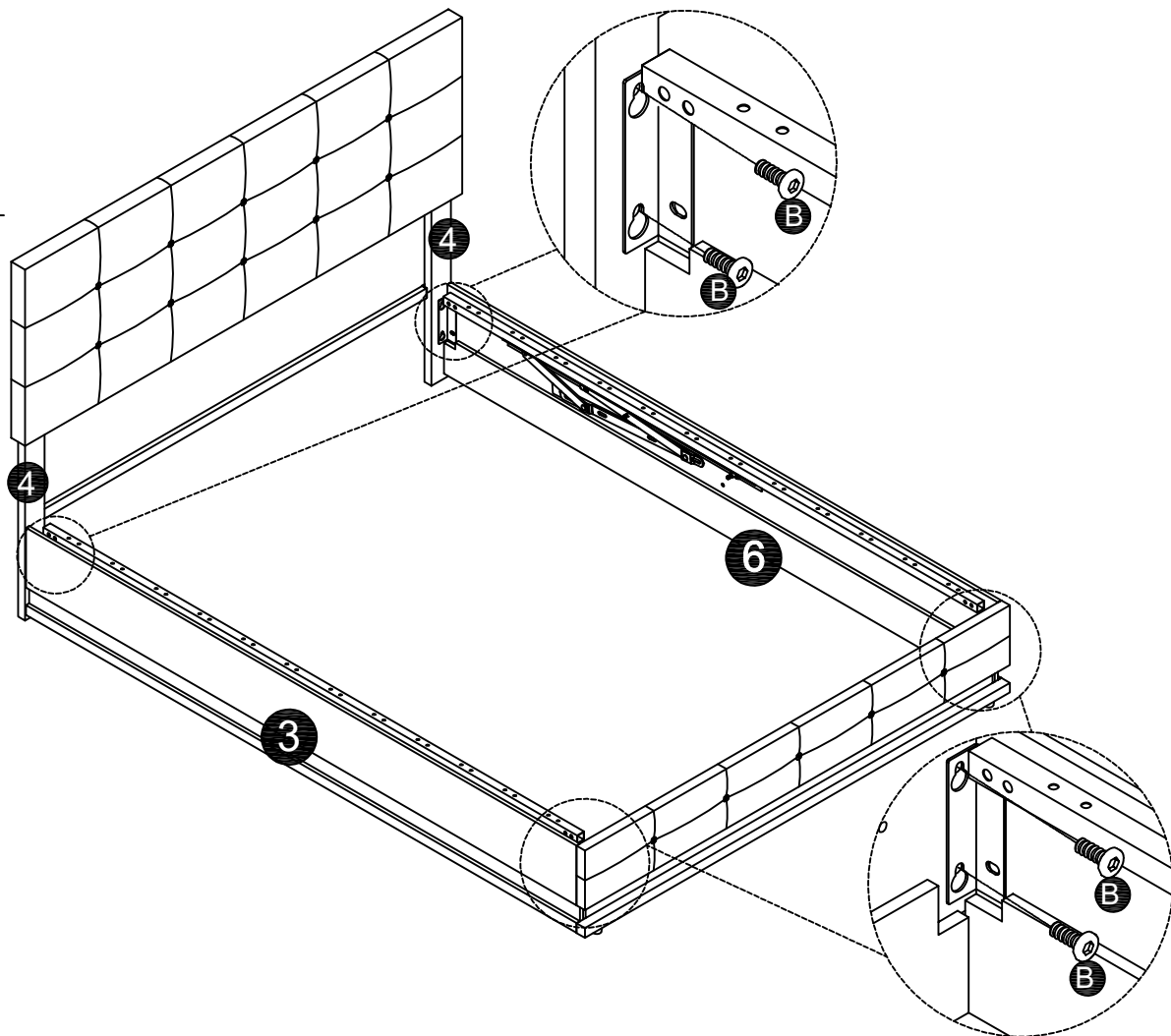
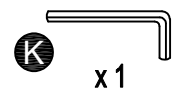
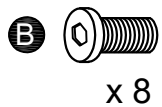

## Step 9:

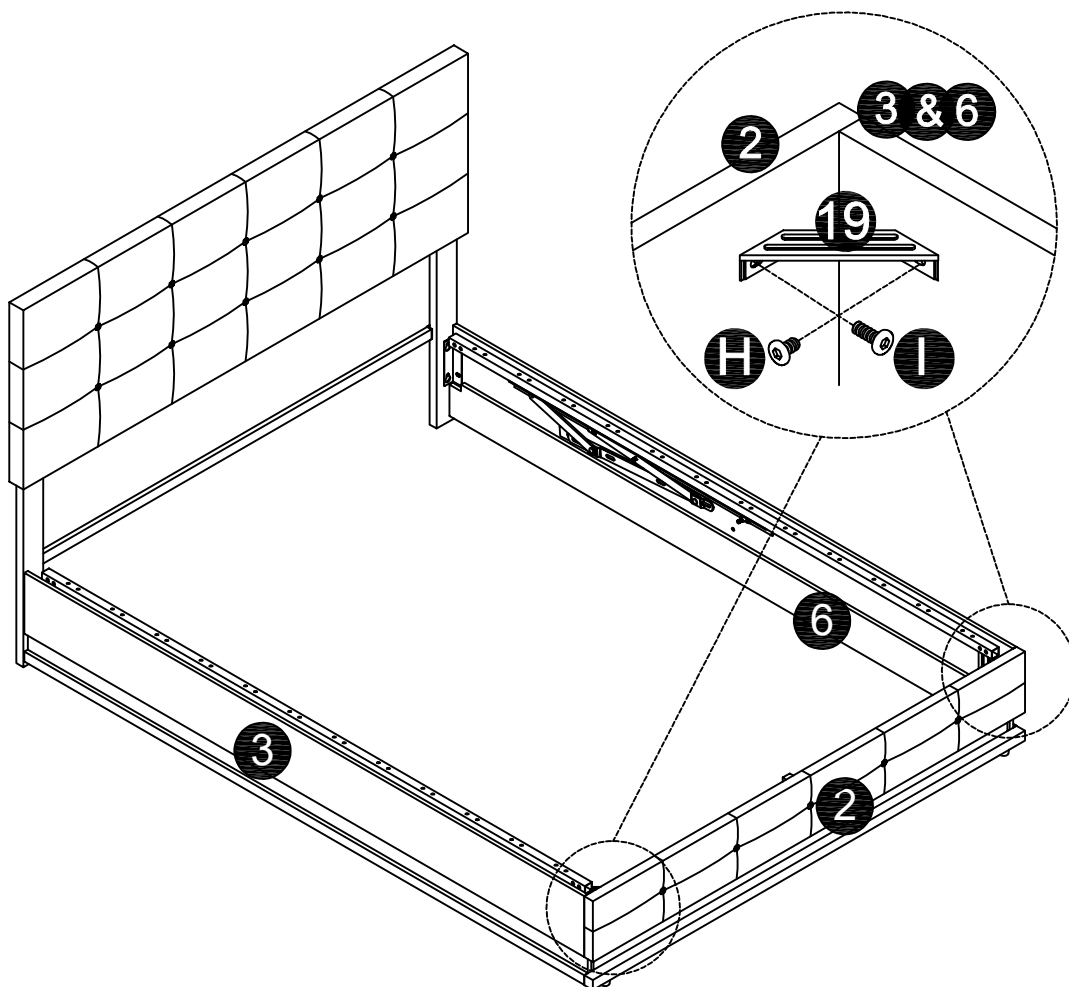
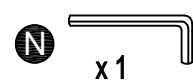
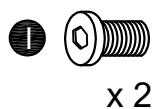
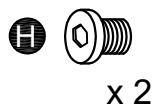

## Step 10:

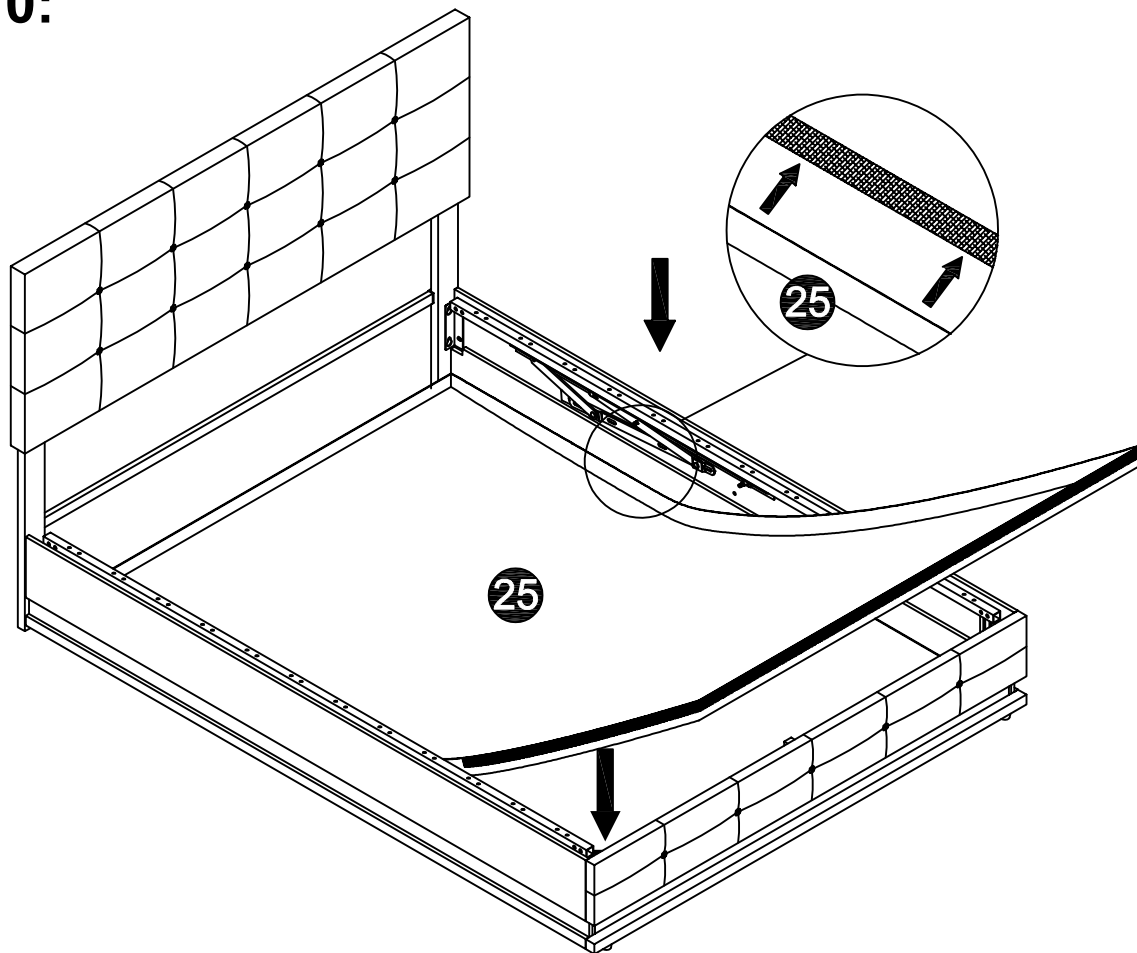

## Step 11:

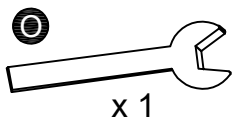
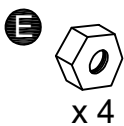

NOTE: Do Not Overtighten

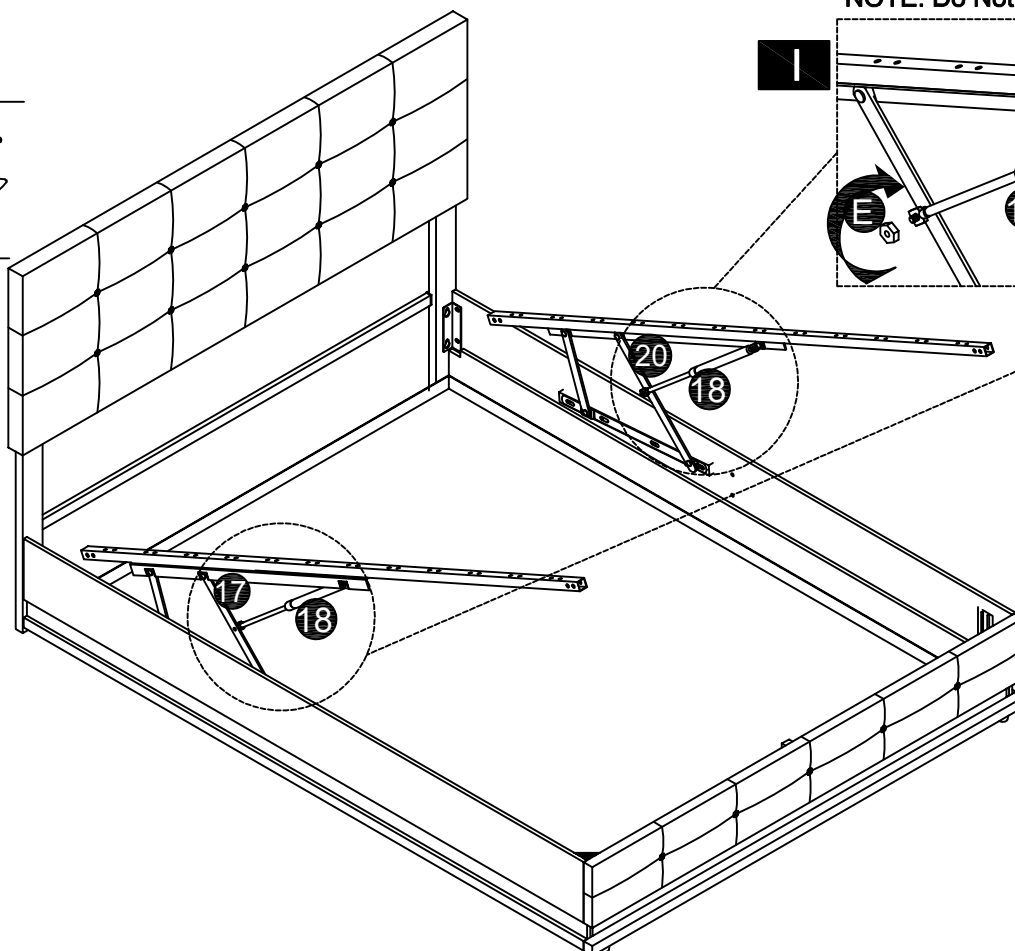
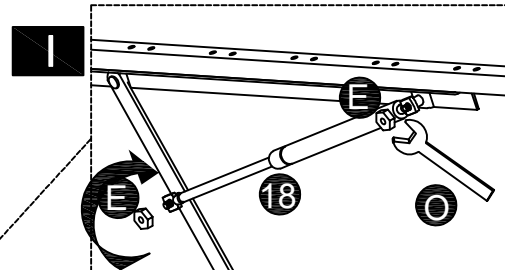

## Step 12:

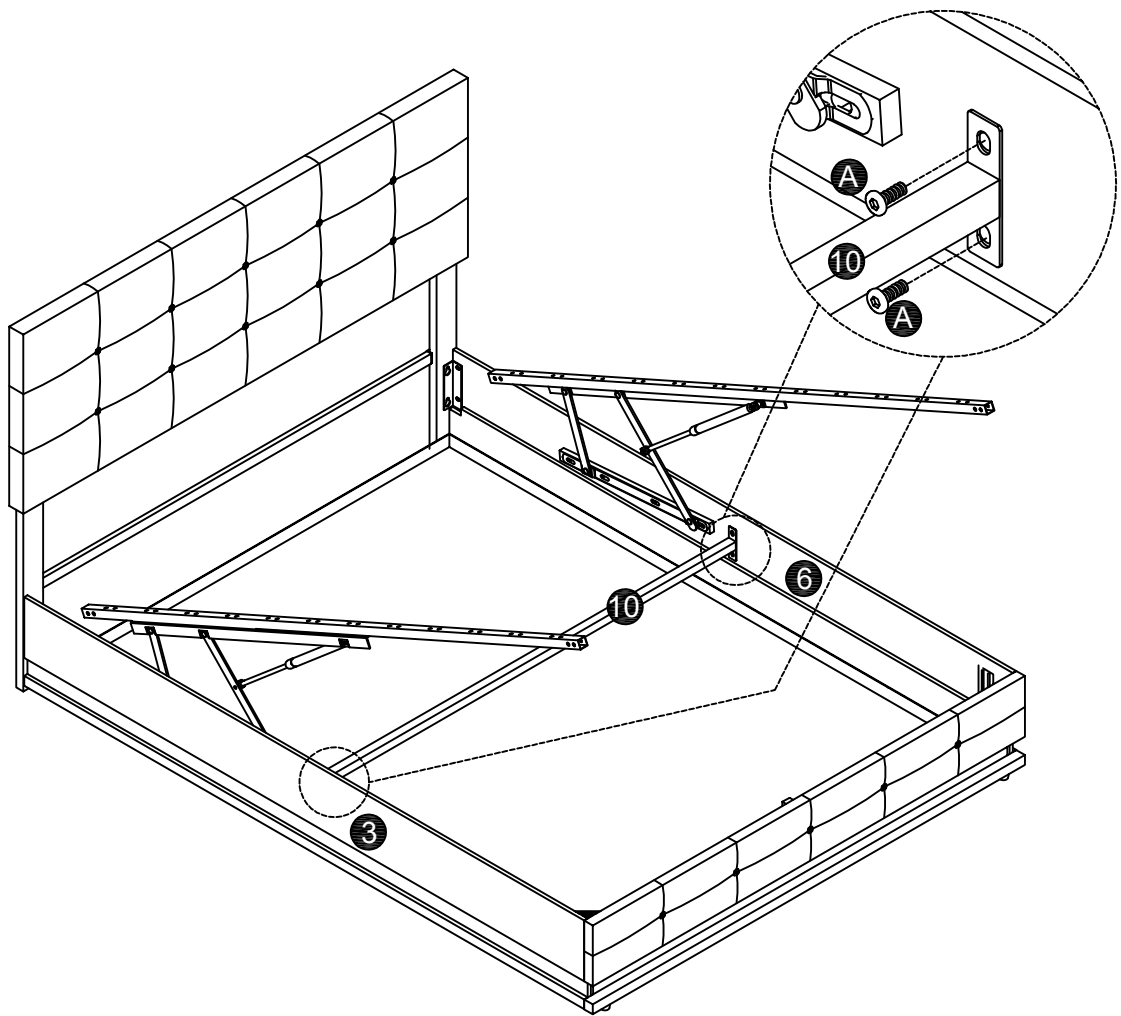
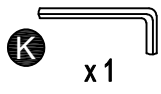
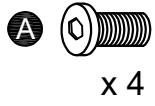

## Step 13:

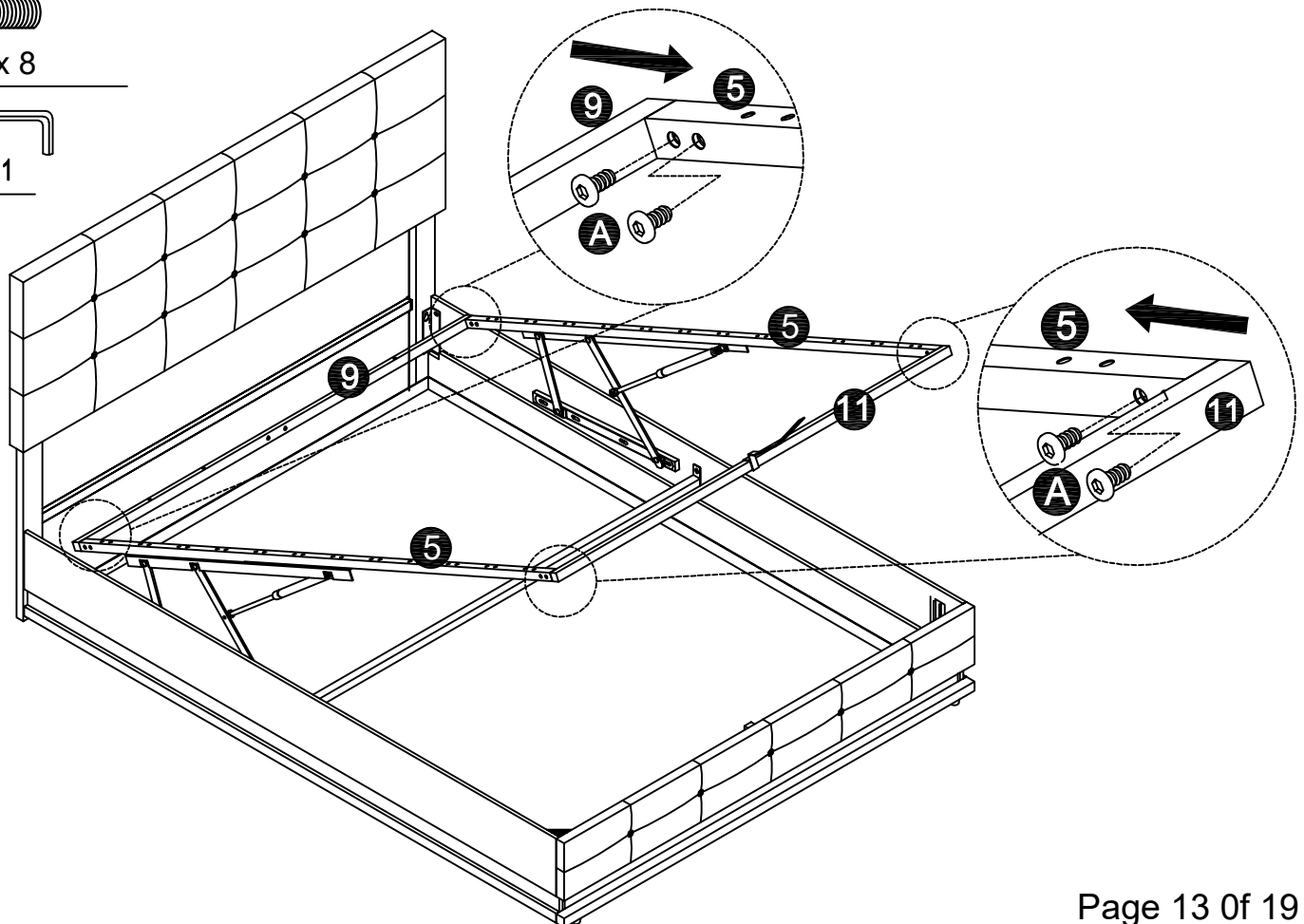
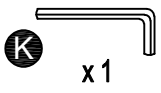
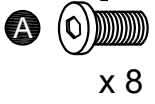

## Step 14:

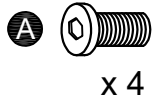

x 4

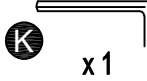

x 1

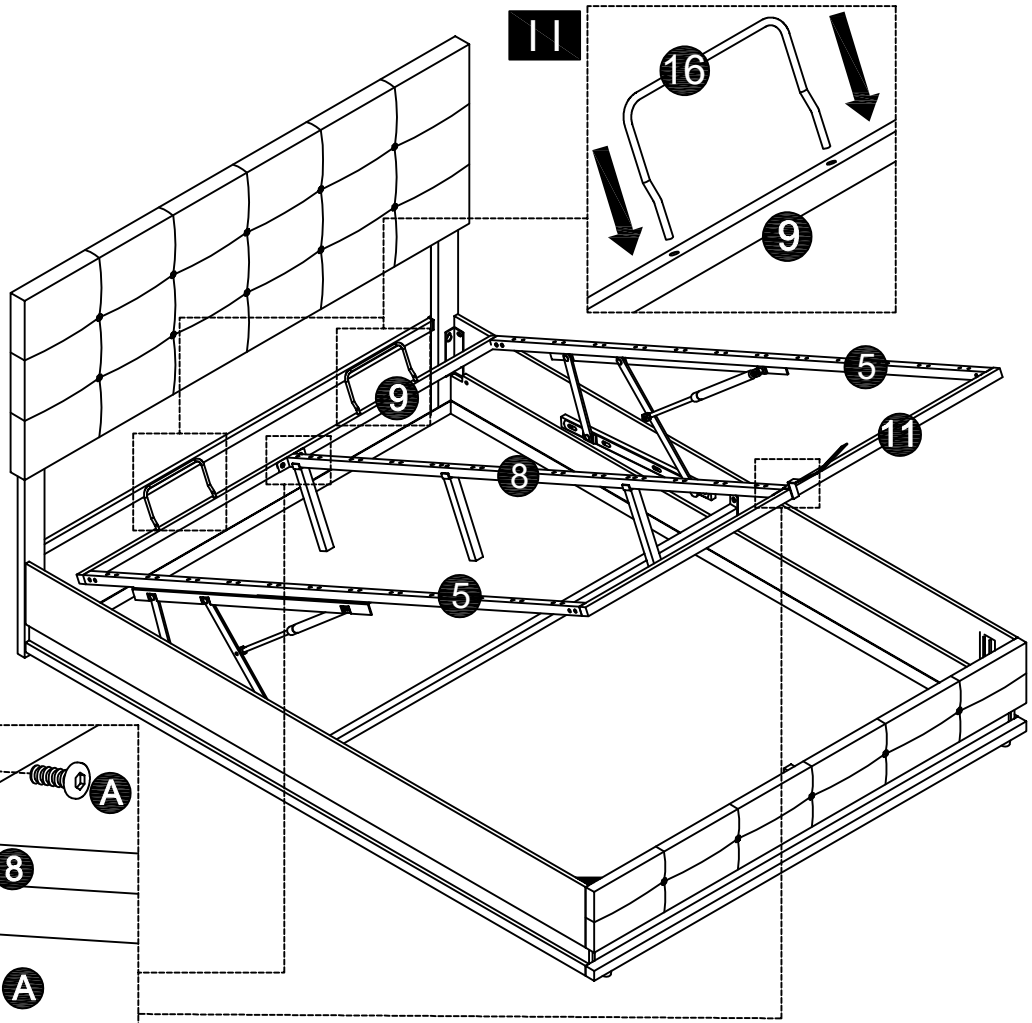

## Step 15:

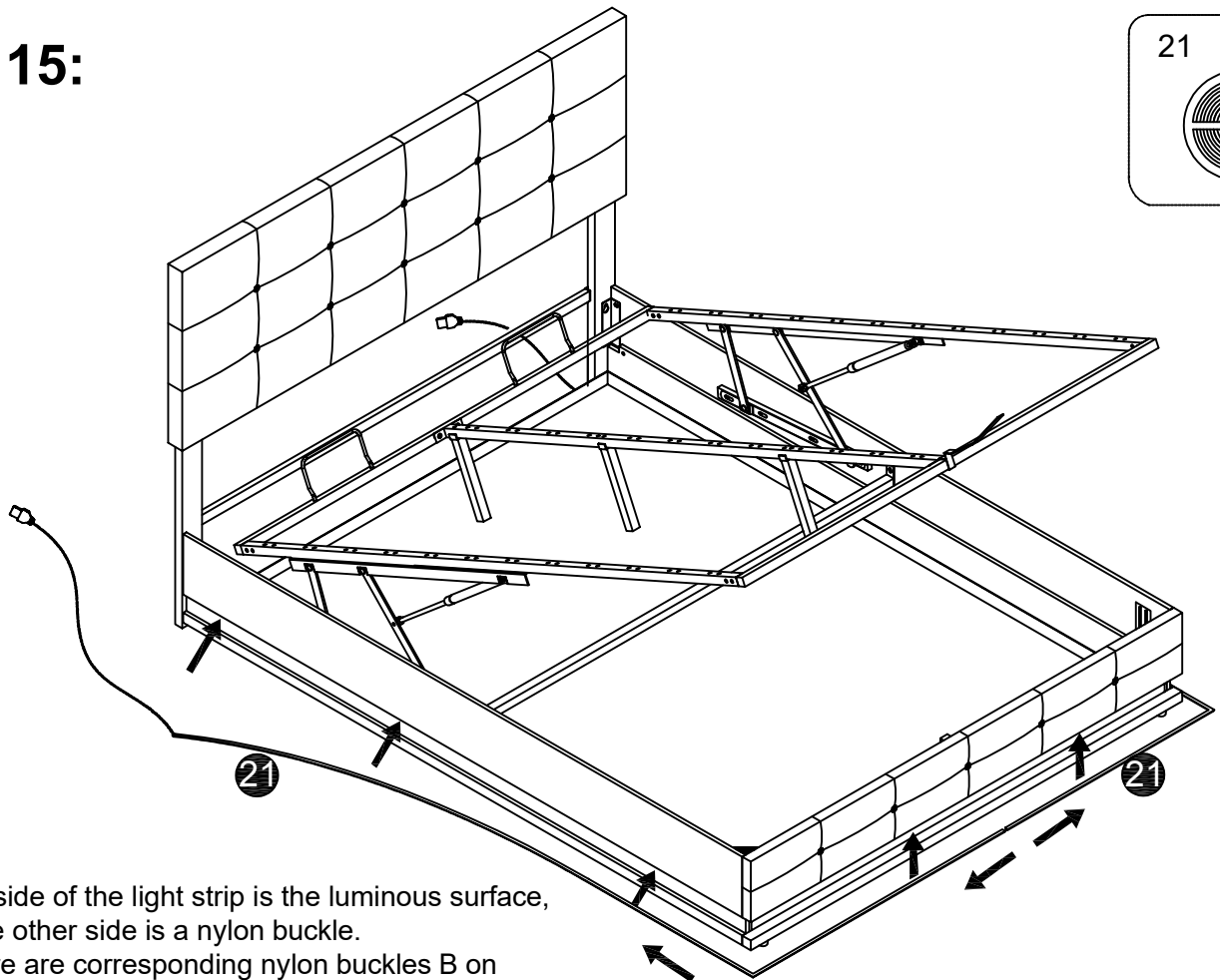
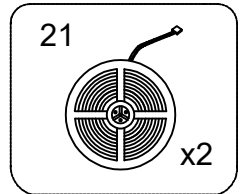

1. One side of the light strip is the luminous surface, and the other side is a nylon buckle.

2. There are corresponding nylon buckles B on the lower part of the bed side and the middle part of the bed tail, which can be firmly bonded.

Please install the light strip in the middle part of the bed side.

# Step 14:

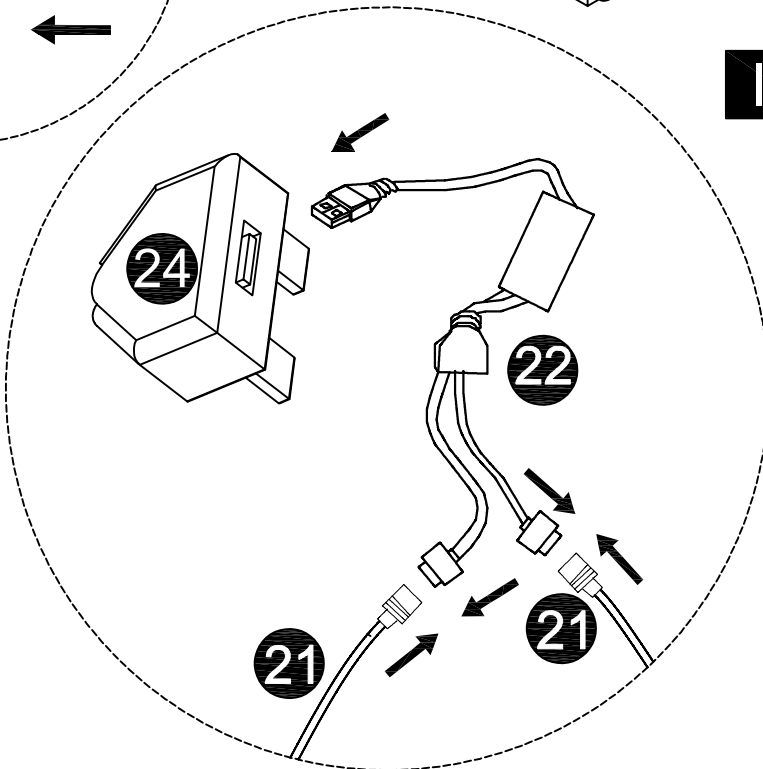
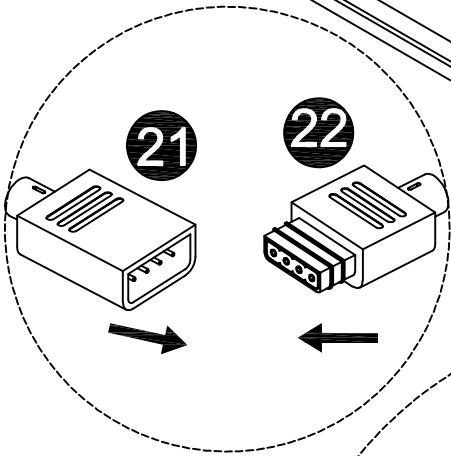
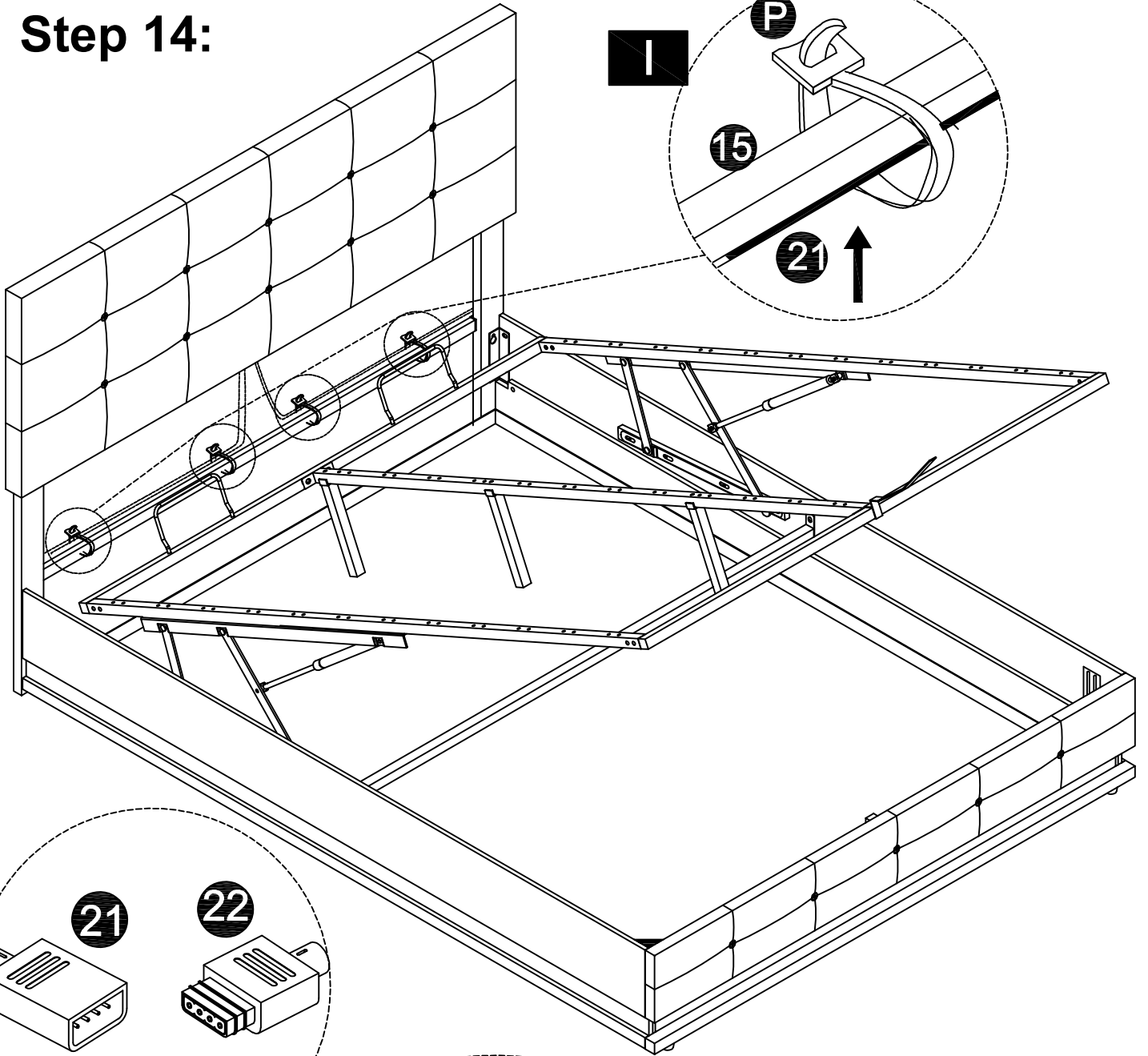

## II

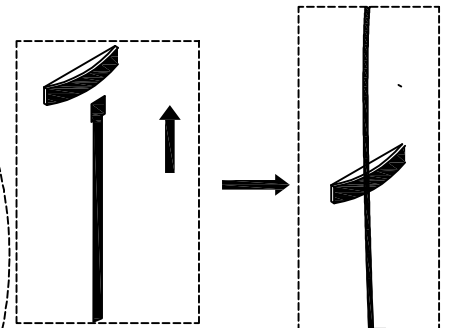

Please string the thread to the elastic band.

# Step 18:

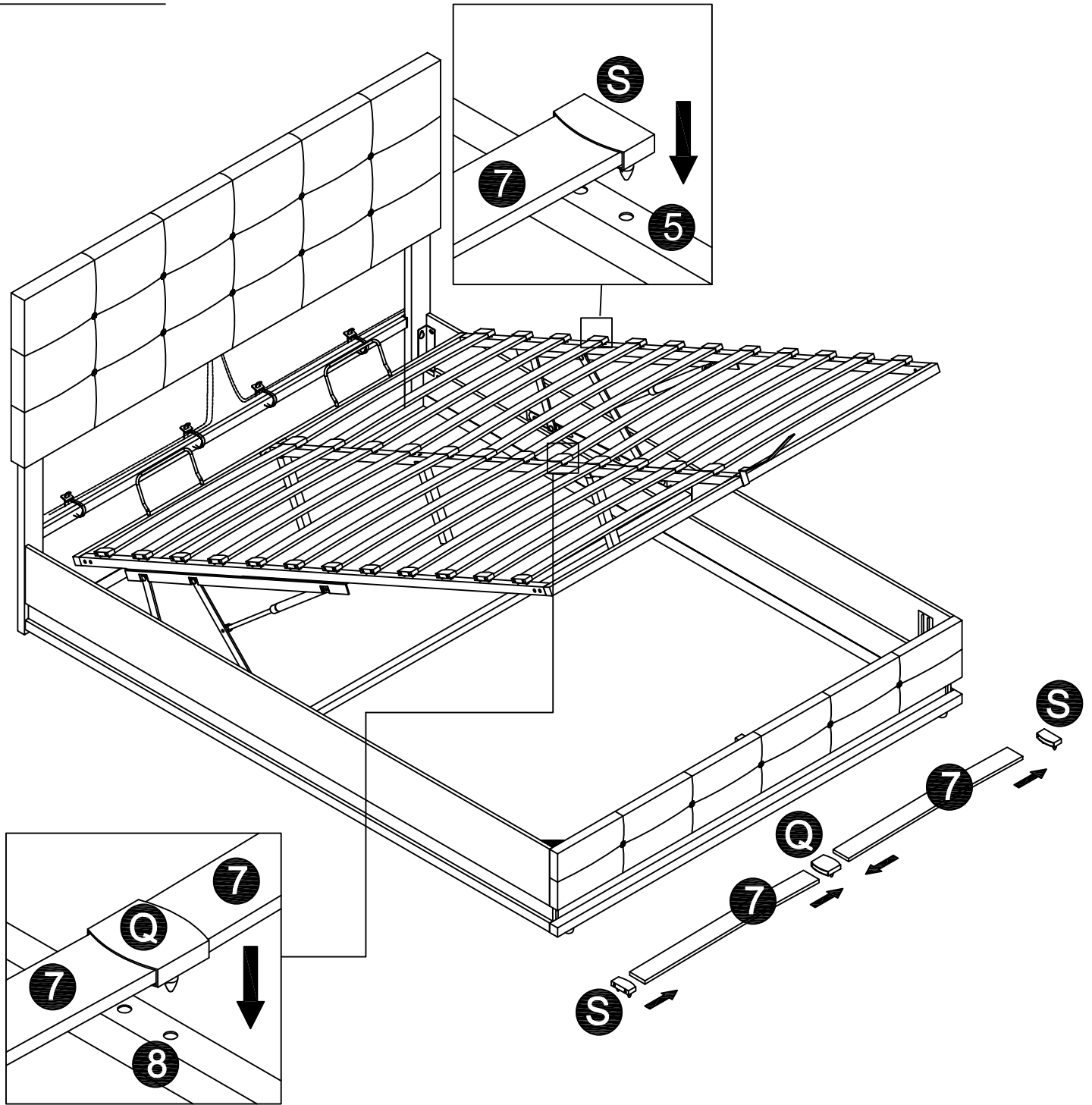
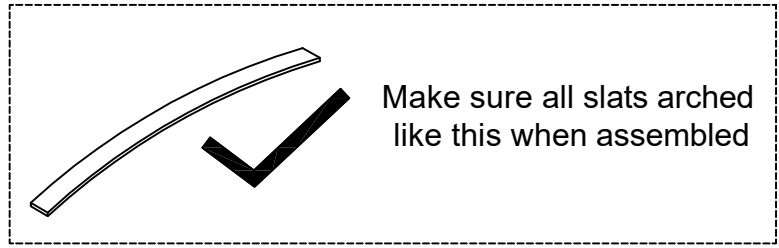
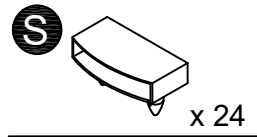
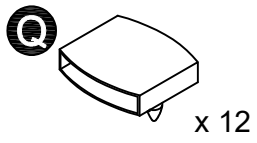

## LED light

If you can't let the lights work successfully, please check the following:

1. Please check the direction of the connect, try it in the opposite direction, according to the following picture.
2. Please check the remote control, it need you to tear down the plastic septum before use it.
3. If one of the colors is not bright, please check whether the four wires in the plug are skewed, and move the main line to make the four wires flush.

### (LED-Licht)

(Wenn Sie die Lampe nicht erfolgreich funktionieren lassen, überprüfen Sie bitte Folgendes:

1. Bitte überprüfen Sie die Verbindungsrichtung und versuchen Sie in der entgegengesetzten Richtung gemäß der Abbildung unten.
2. Bitte überprüfen Sie die Fernbedienung und entfernen Sie die Kunststoffmembran vor Gebrauch.
3. Wenn eine der Farben nicht hell ist, überprüfen Sie bitte, ob die vier Drähte im Stecker schief sind, und bewegen Sie die Hauptleitung, um die vier Drähte bündig zu machen.)

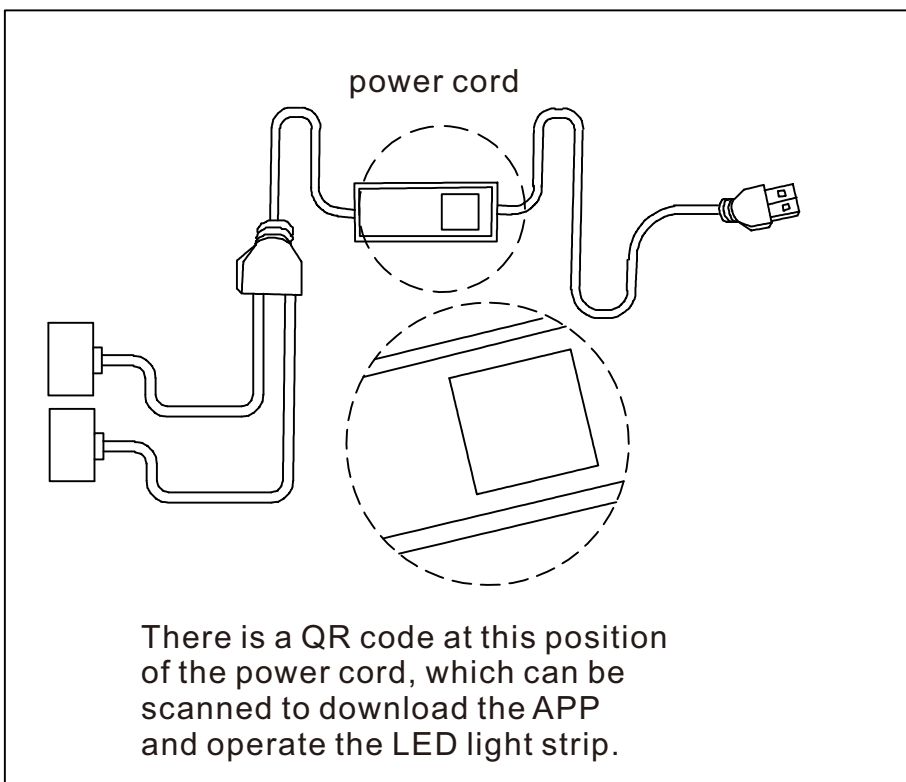
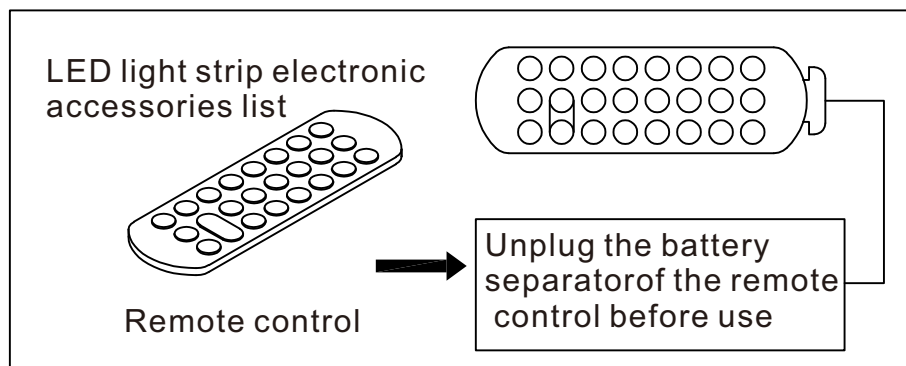
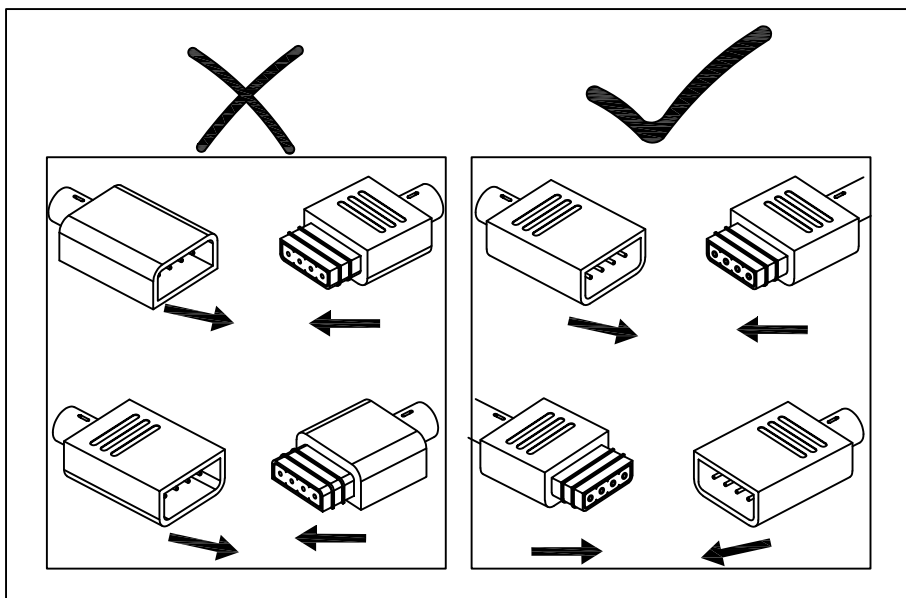

1. Please check the direction of the arrow
2. Please pull the plastic block out of the remote control
3. Please check whether the four wires of the plug are neat

- (1. Bitte überprüfen Sie die Richtung des Pfeils
2. Ziehen Sie bitte den Kunststoffblock von der Fernbedienung
3. Bitte überprüfen Sie, ob die vier Drähte des Steckers bündig sind)

## Operation Instructions of Controller (Betriebsanleitung des Reglers)

### I. Specifications: (Spezifikationen)

Working temperature: -20-60 °C  
(Arbeitstemperatur: -20-60 °C)

Supply voltage: DC12V  
(Versorgungsspannung: DC12V)

Product size: L62xW35xH23mm  
(Produktgröße: L62xW35xH23mm)

Package size: L95xW68xH45mm  
(Packungsgröße: L95xW68xH45mm)

Net weight: 42g  
(Nettogewicht: 42g)

Gross weight: 57g  
(Bruttogewicht: 57g)

Output: Three CMOS drain- open output  
(Ausgabe: Drei CMOS Drain- Open Ausgang)

Connecting Mode: Common anode  
(Verbindungsmodus: Gemeinsame Anode)

Max load current: 2 A each color  
(Maximaler Ladestrom: 2 A pro Farbe)

### II. Control Method:

Adopt RF remoter to control the led controller, which has 24 buttons, the function of each button as the table below:

(Kontrollmethode:

Nehmen Sie RF-Fernbedienung an, um den geführten Controller zu steuern, der 24-Tasten hat, die Funktion jeder Taste wie die Tabelle unten:)

Brightness +(Speed up) (Helligkeit +(Beschleunigung))	Brightness - (Speed down) (Helligkeit - (Geschwindigkeit runter))	Off (Aus)	On (Ein)
Static red (Statisches Rot)	Static green (Statisch grün)	Static blue (Statisch blau)	Static white (Statisch weiß)
Static orange (Statisch orange)	Static pea green (Statisches Erbsengrün)	Static dark blue (Statisch dunkelblau)	7 color jumpy change (7 Farbwechsel)
Static dark yellow (Statisch dunkelgelb)	Static cyan (Statisches Cyan)	Static brown (Statisch braun)	All fade out&fade in (All fade out&fade in)
Static yellow (Statisch gelb)	Static light blue (Statisch hellblau)	Static pink (Statisch rosa)	7 color fade change (7 Farbwechsel)
Static straw yellow (Statisches Strohgelb)	Static sky blue (Statisches Himmelblau)	Static purple (Statisches Lila)	3 base color jumpy (3 Grundfarbe nervös)

### III. Panel specification and connecting drawing as follows: (Plattenspezifikation und Anschlusszeichnung wie folgt)

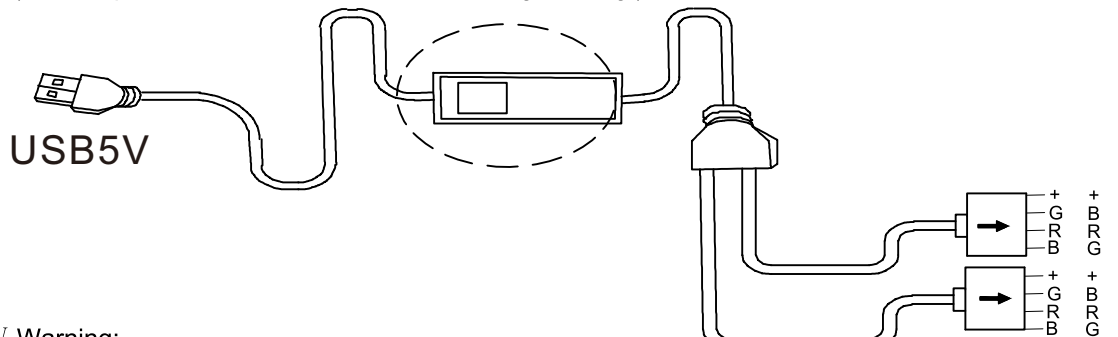

### IV. Warning:

1. Supply voltage of this product is USB5V never connect to DC24V or AC220V.
2. Never connect two wires directly in case of short circuit.
3. Lead wire should be connected correctly according to colors that connecting diagram offers.
4. Warranty of this product is one year, in this period we guarantee replacement or repairing with no charge, but exclude the artificial situation of damaged or overload working.

### (Warnung:

1. Supply Spannung dieses Produkts ist USB5V niemals mit DC24V oder AC220V verbinden.
2. Nie verbinden Sie zwei Drähte direkt im Falle eines Kurzschlusses.
3. Lead Draht sollte entsprechend den Farben richtig angeschlossen werden, die Verbindungsdiagramm anbietet.
4. Warranty dieses Produkts beträgt ein Jahr, in diesem Zeitraum garantieren wir Ersatz oder Reparatur ohne Gebühr, schließen aber die künstliche Situation der beschädigten oder überlasteten Arbeit aus.)

## ! WARNING

### THIS PRODUCT CONTAINS A BUTTON BATTERY

If swallowed, a lithium button battery can cause severe or fatal injuries within 2 hours.

Keep batteries out of reach of children.

If you think batteries may have been swallowed or placed inside any part of the body, seek immediate medical attention.

## ! WARNUNG

### Dieses Produkt enthält eine Knopf-Batterie

Beim Verschlucken kann eine Lithium-Knopf-Batterie innerhalb von zwei Stunden schwere oder tödliche Verletzungen verursachen.

Bewahren Sie Batterien außerhalb der Reichweite von Kindern auf.

Wenn Sie glauben, dass Batterien verschluckt oder in einen Teil des Körpers gelegt wurden, suchen Sie sofort einen Arzt auf.

# Attestation of Compliance

<b>Declaration No.:</b>	MK23110141P01-E01
<b>Name and address of Applicant:</b>	<b>Shenzhen Hongzhengyu Technology Co., LTD</b> Shenzhen baoan district rock street industrial science and technology industrial park of 2 Haitian lanyu 3 5 floor of A
<b>Name and address of Manufacturer:</b>	<b>Shenzhen Hongzhengyu Technology Co., LTD</b> Shenzhen baoan district rock street industrial science and technology industrial park of 2 Haitian lanyu 3 5 floor of A
<b>Product name:</b>	<b>RGB package</b>
<b>Rated:</b>	DC5V
<b>Product model(s):</b>	HZY-5050RGB-30D-90R-DC5V, HZY-5050RGB-30D-30R-DC5V, HZY-5050RGB-60D-60R-DC5V, HZY-5050RGB-60D-180R-DC5V, HZY-5050RGB-18D-18R-DC5V
<b>Product trademark:</b>	N/A

This Attestation of Compliance confirms that the product meets the requirements of the following standard.

BS EN IEC 55015:2019+A11:2020  
IEC 61547:2020  
BS EN IEC 61000-3-2:2019  
BS EN 61000-3-3:2013/A2:2021

*The Attestation of Compliance has been carried out in accordance with individual rules and conditions agreed with the applicant. Evaluation has been carried out in accordance with:*

<b>Test report(s) No.:</b>	MK23110141P01-E01
<b>Test conducted by:</b>	TMC Testing Services (Shenzhen) Co., Ltd.
<b>Declaration issue date:</b>	December 5, 2023

**Notes:**

*This Attestation of Compliance is issued according to the Great Britain legislation Electromagnetic Compatibility Regulations 2016( SI 2016 No. 1091). It confirms that the listed products complies with all essential requirements of the Regulations and applies only to the sample and its technical documentation to TMC Testing Services (Shenzhen) Co., Ltd. for testing.*

*After preparation of the necessary technical documentation (which must be kept for up 10 years after the product is placed on the GB market) as well as the UK Declaration of Conformity, the required UKCA marking can be affixed on the product. Other relevant Regulations have to be observed.*

**TMC Testing Services (Shenzhen) Co., Ltd.**

t:86-755-86642861 cert@tmc-lab.com www.tmc-lab.com

1st Floor, Block A1, Zone A, Xinshidai Gongrong Industrial Park, No. 2, Shihuan Road, Shiyuan Street, Baoan District, Shenzhen, China



*Vivian Jiang*  
Lab Director  
Vivian Jiang

**UK  
CA**

Shenzhen KOT Testing Technology Co.,Ltd.

7/F, Building 1, Xunyuan Zhichuanggu Industrial Park, Fengtang

Avenue, Fuhai Street, Baoan District, Shenzhen



# Certificate of Compliance

Certificate Number: KOT-2021035986C

<b>Certificate's Holder</b>	<b>:</b> SHEN ZHEN BAIZE ELECTRONIC TECHNOLOGY LIMITED FL3 BLDG A XIXIANG GUSUKANGYUANINDUSTRIAL ZONE BAOAN DIST SHENZHEN, CHINA
<b>Manufacturer</b>	<b>:</b> SHEN ZHEN BAIZE ELECTRONIC TECHNOLOGY LIMITED FL3 BLDG A XIXIANG GUSUKANGYUANINDUSTRIAL ZONE BAOAN DIST SHENZHEN, CHINA
<b>Product</b>	<b>:</b> Charger
<b>Trade Mark</b>	<b>:</b> N/A
<b>Model(s)</b>	<b>:</b> BZ-A017-1 BZ-A0XX, BZ-A002, BZ-A003, BZ-A004, BZ-A005, BZ-A006, BZ-A007, BZ-A008, BZ-A009, BZ-A010, BZ-A011, BZ-A012, BZ-A013, BZ-A014, BZ-A015, BZ-A016, BZ-A017, BZ-A017-1, BZ-A018, BZ-A019, BZ-A020, BZ-A0XXX.
<b>Test Standard</b>	<b>:</b> EN 55032:2015+A11:2020, EN 55035:2017+A11:2020 EN 61000-3-2:2019, EN 61000-3-3:2013+A1:2019 EN 61000-4-2:2009, EN 61000-4-3:2020, EN 61000-4-4:2012, EN 61000-4-5:2014+A1:2017, EN 61000-4-6:2014, EN 61000-4-8:2010, EN 61000-4-11:2020

This Attestation of Compliance is issued on a voluntary basis for electrical equipment below the voltage limits of EMC Directive 2014/30/EU. The essential requirements are fulfilled accordingly based on the technical specifications applicable at the time of issuance. See also notes overleaf. It is only valid in connection with the test report number: KOT-2021035986C.

