

Assembly Instruction Sheet

Tools Required: Flathead screwdriver, Phillips screwdriver, pliers, wire cutters, wire strippers, electrical tape, safety glasses.

Bulb Recommended: (1) Medium Base 100W Maximum

Estimated Assembly Time: 20-30 minutes

Preparation: Identify and inspect all parts before beginning installation. Check package content list and diagrams below to be sure all parts are present. If any parts are missing or damaged, do not attempt to assemble, install, or operate the fixture.



Warnings and Cautions

Turn off electricity at circuit breaker or main fuse box before installation. Consult a licensed electrician if in doubt.

These instructions are provided for your safety. It is very important you read them completely before installing the fixture. We strongly recommend that a licensed, professional electrician perform the installation.

Disconnect fixture from power source before replacing bulbs. Make sure bulbs are given sufficient time to cool before removal. Do not subject glass parts to any shock while in operation or shattering December result.

Package Contents

Part	Description	Quantity
A	Crossbar	1 pc.
B	Mounting Screw	2 pcs.
C	Lock Washer	2 pcs.
D	Hex Nut	2 pcs.
E	Mounting Ball	2 pcs.
F	Fixture Body	1 pc.

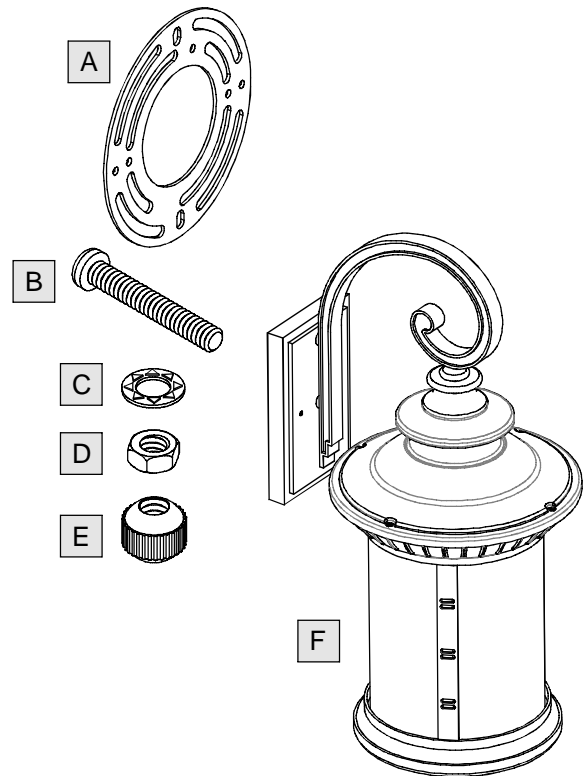

FINISH: IMPERIAL BRONZE

1

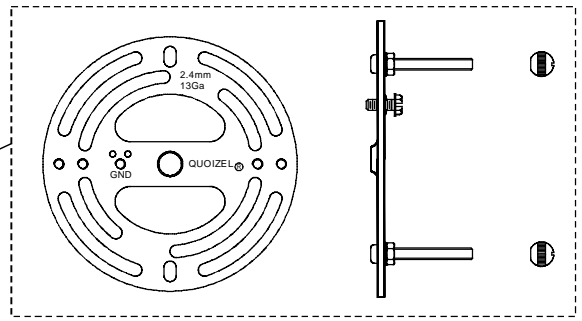

2

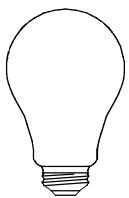
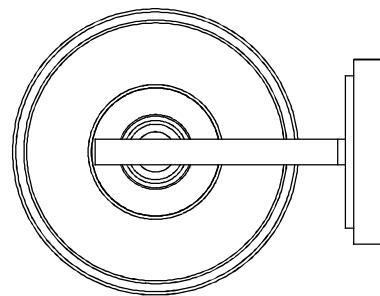
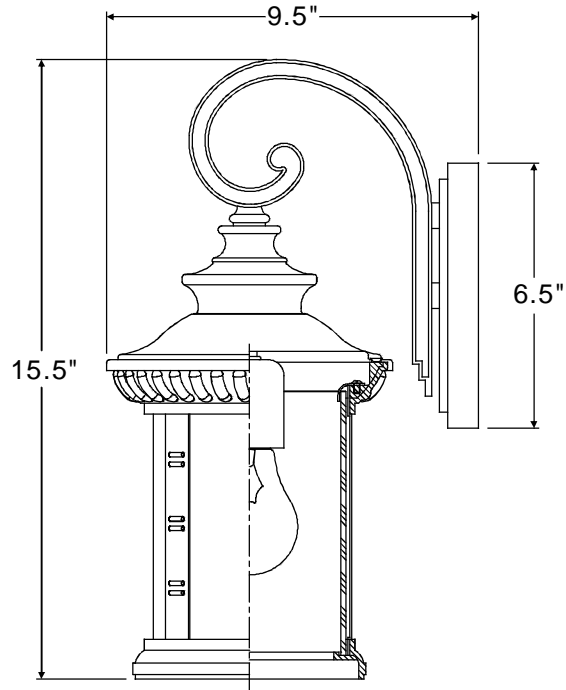
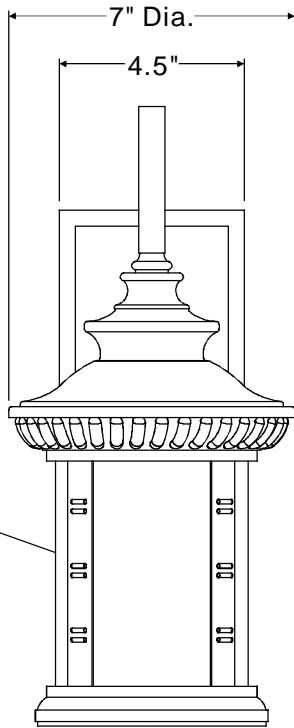

(1)100W Medium Base Bulb (Not Supplied)

NOTE: ALL DIMENSIONS ARE ROUNDED UP TO THE NEAREST 1/2"

NO.	PART NUMBER	REPLACEMENT PART DESCRIPTION	REQ.
1	9465KIT	MTG HARDWARE IMPR BRNZ 4"D	1
2	G2859SH	SHADE CLEAR WATER GLASS	1

Assembly Instruction Sheet

STEP 1 - Take Cage with Shade apart

- A. Take the Cage with Shade apart by unscrewing Socket Head Cap Screw.

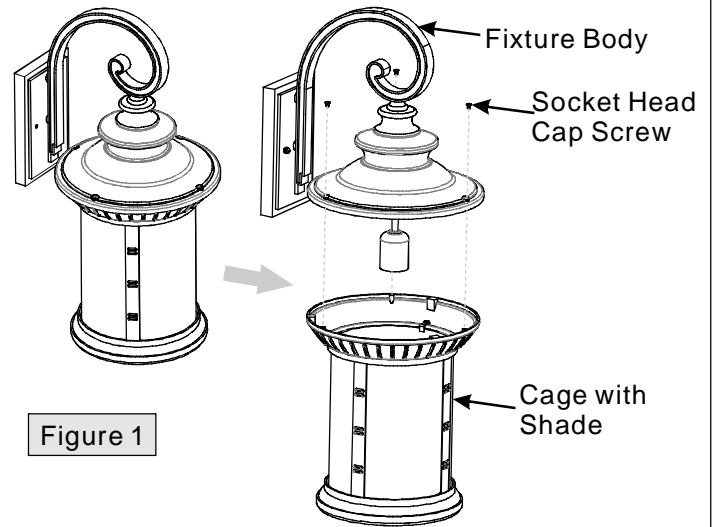

STEP 2 - Remove PE Foam, Sponge and Styrofoam

- A. Remove the Styrofoam inside of the Cage.
B. Take out the Glass by unscrewing Lock Screws and Tabs. Remove PE Foams and Sponges around the Glass.
C. Place the Glass back into the Cage and secure with the Tabs and the Lock Screws.
D. Unscrew the Socket Head Cap Screws from the top edge of the Cage.

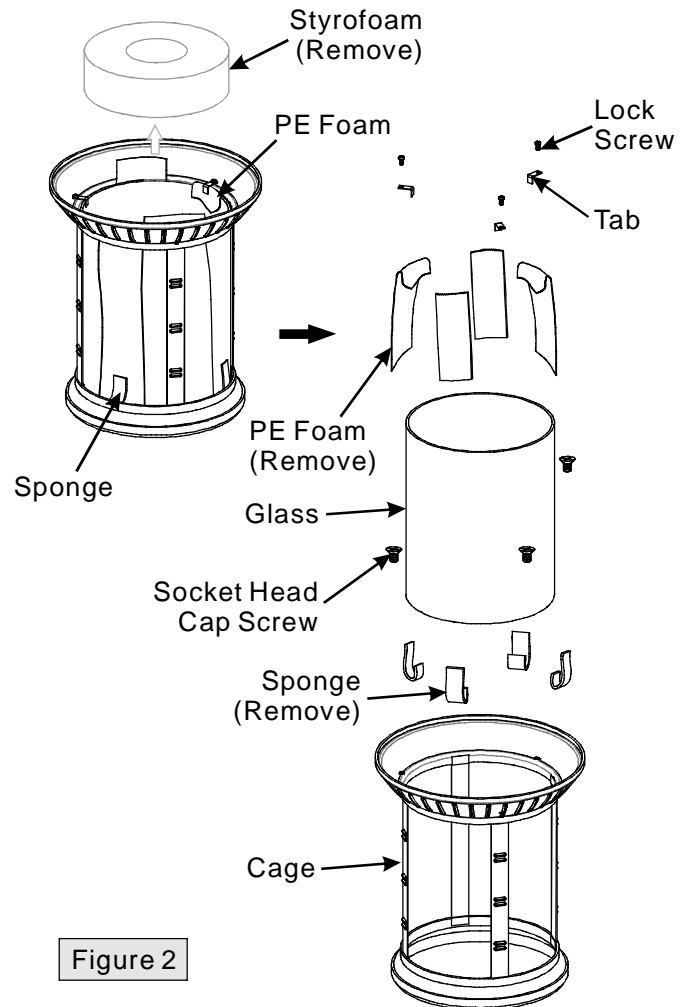

Assembly Instruction Sheet

STEP 3 - Install Cage back Fixture Body

- A. Place the Cage with Shade over the Hood on Fixture Body (I). Secure by threading the Socket Head Cap Screws into the mounting holes on the top edge of the Cage. Hand tighten until snug.

Figure 3

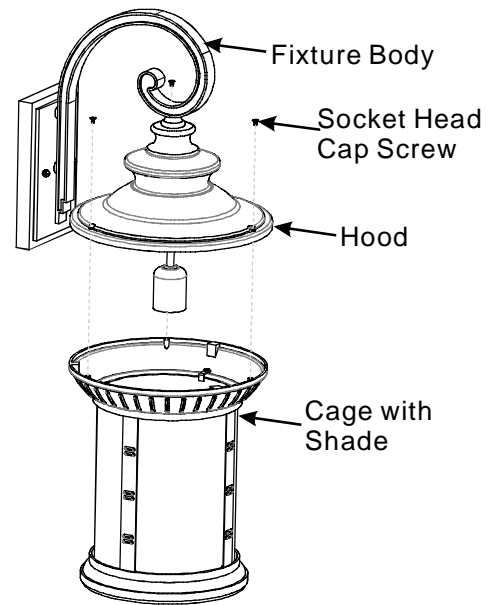

STEP 4 - Attach Mounting Screws, Lock Washers and Hex Nuts to Crossbar

- A. Line up a set of holes on the Crossbar (A) and Holes on the backplate of the Fixture Body (F).
B. Thread Mounting Screws (B) into the holes on the Crossbar (A), pass Lock Washers (C) and thread Hex Nut (D) onto the Mounting Screws (B). Hand tighten until snug.

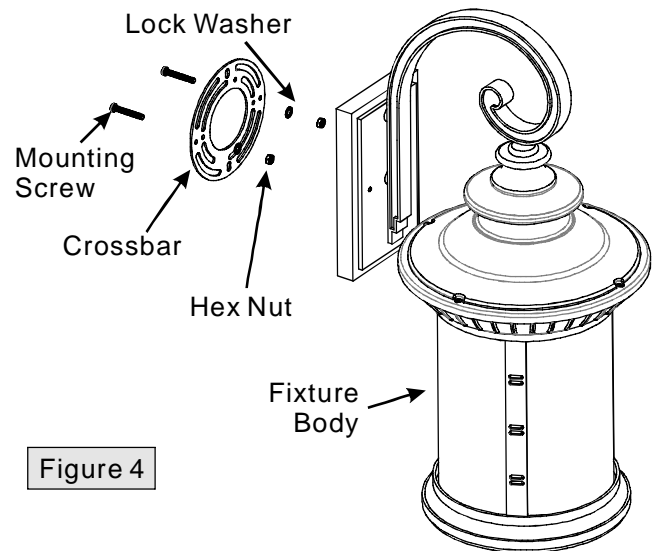
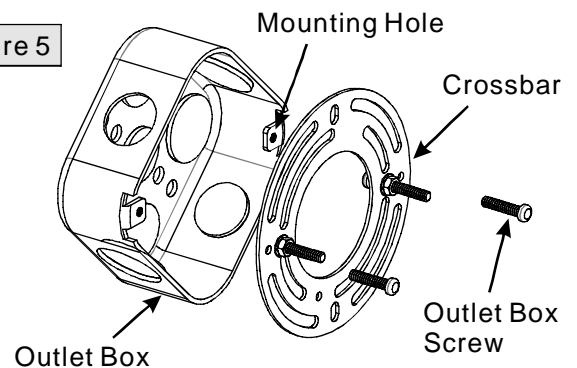

Figure 4

STEP 5 - Attach Crossbar to Outlet Box

- A. Attach the Crossbar (A) to Outlet Box and secure by threading Outlet Box Screws (not supplied) into the Mounting Holes on the Outlet Box. Tighten until snug.

Figure 5



Assembly Instruction Sheet

STEP 6 - Make Wire Connections

- A. Use standard wire connectors to make all wire connections. (Connectors are not included with fixture.) Strip and prepare wire ends according to instructions supplied with connectors.
- B. Connect White Supply Wire from the Outlet Box to White Wire from fixture.
- C. Connect Black (or Red) Supply Wire from the Outlet Box to Black Wire from fixture.
- D. Connect Ground Wire from the Outlet Box to Ground Wire from fixture.
- E. Twist connectors until wires are tightly joined together.
- F. Wrap each connection with approved electrical tape and carefully stuff all the connected wires into the Outlet Box.

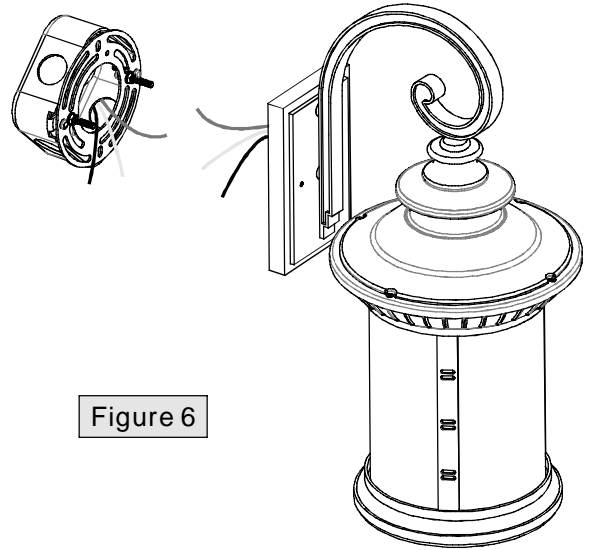

Figure 6

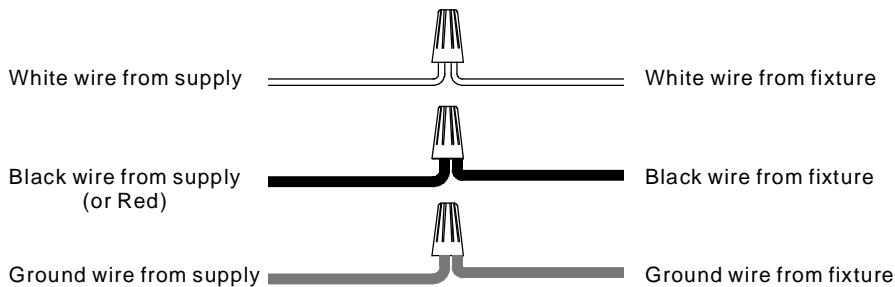

Figure 7

STEP 7 - Attach Fixture Body to Mounting Screw

- A. Place the backplate of the Fixture Body (F) over the Mounting Screws (B) and secure with Mounting Balls (E). Hand tighten until snug.

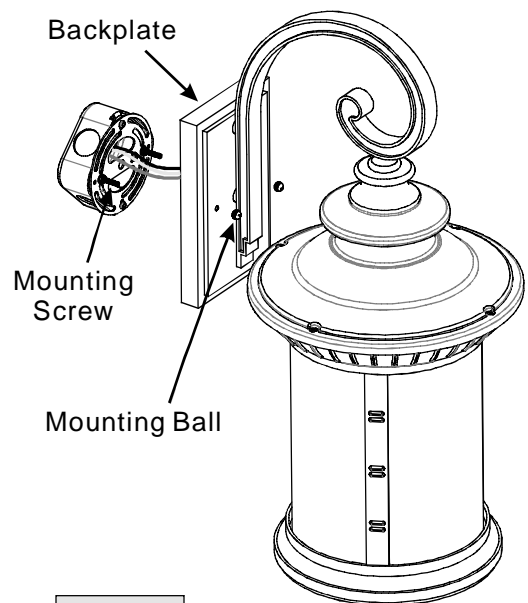

Figure 8

Assembly Instruction Sheet

STEP 8 - Install Bulb

- A. This fixture uses standard bulb with a medium screw base. Maximum 100 watts.
- B. Insert bulb and screw snugly into place.

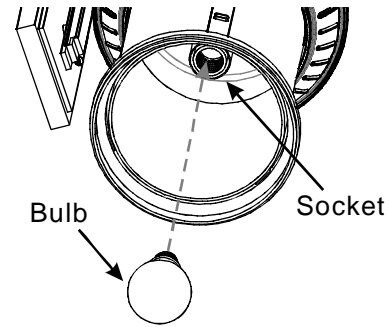

Figure 9

STEP 9 - Apply Silicone Sealer to Mounting Balls

- A. To prevent moisture from entering the wire compartment, apply a small amount of silicone sealer (not included) to the threaded side of the mounting balls (E) and then install them onto the mounting screws (B). Wipe off excess caulk.

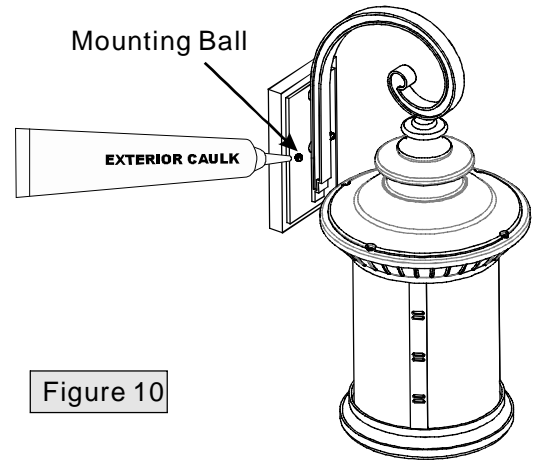

Figure 10

STEP 10 - Apply Silicone Sealer to Backplate

- A. Make sure exterior wall surface and fixture backplate are free of dirt before applying caulk. Using exterior grade caulk, start on one side of fixture backplate and follow contour, where the fixture backplate meets the exterior wall surface upward. Proceed to caulk over top of backplate and down other side. Do not caulk bottom of fixture backplate to ensure proper moisture drainage.

Your lamp wall fixture is now assembled and ready to use. Enjoy!

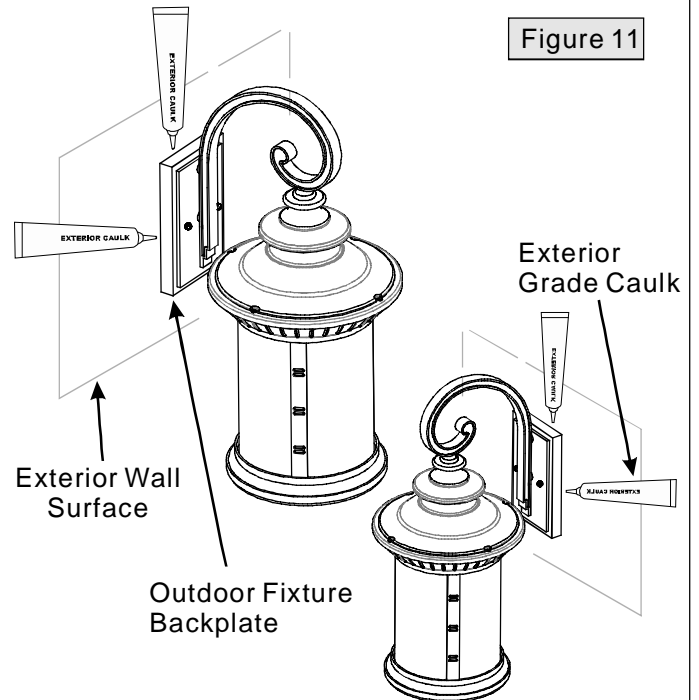

Figure 11