

N620P386804 / N620P386805 / N620P386806

N639P386889 / N639P386890 / N639P386891

Product manual

Gebrauchsanweisung

Manuel du produit

Manual del producto

Manuale del prodotto

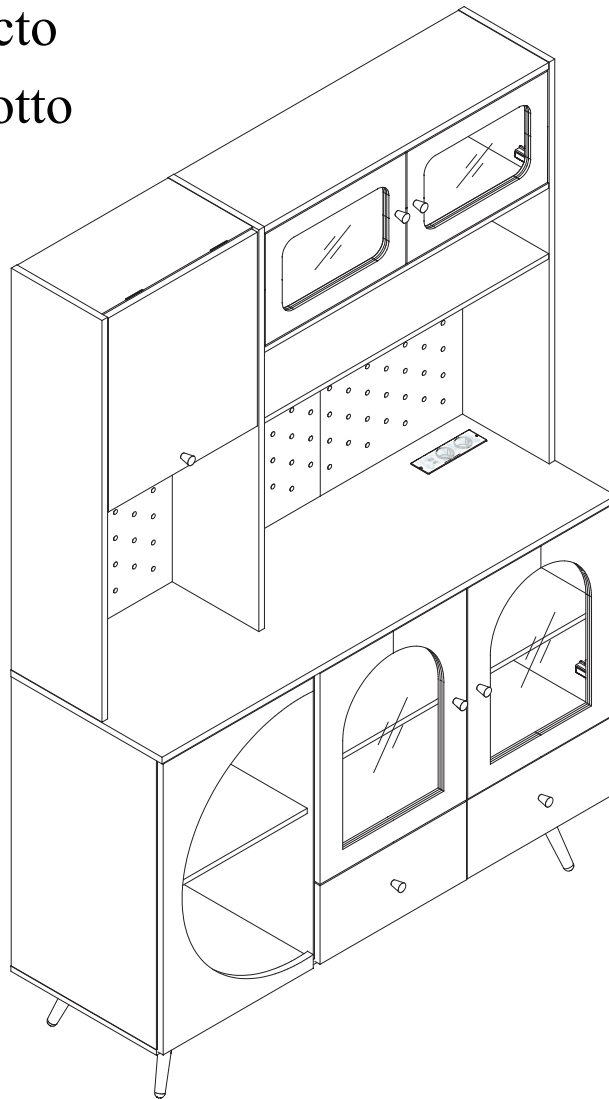

EN:Our product will be delivered to you in 2 packages.

The delivery times of these 2 packages may differ, please be patient and thank you for your understanding

FR:Notre produit vous sera livré en 2 colis.Les delais de livraison de ces 2 colis peuvent différer,soyez patient et merci de votre compréhension.

DE:Unser Produkt wird Ihnen in 2 Paketen geliefert.Die Lieferzeiten dieser 2 Paketekonnenabweichen,bitte haben Sie etwas Geduld und vielen Dank für Ihr Verständnis

IT:I nostri prodotti vengono trasportati in due pacchetti. I tempi di consegna dei due pacchetti sono diversi:

abbiate pazienza e vi ringrazio per la vostra comprensione

ES:Nuestro producto se entrega en dos paquetes. El tiempo de entrega de estos dos paquetes es diferente. Por favor, sea paciente. Gracias por su comprensión.



FR

Pensez à donner ou recycler.



Association



Magasin



Déchèterie

<https://quefairedemesdechets.fr>



2PERS



45 MIN

Tool Required Not Provided

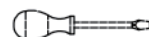



[DE]

Warnung: Lesen Sie die Anleitung vor dem Zusammenbau bitte vollständig durch. Überprüfen Sie, ob Sie alle auf den Seiten aufgeführten Komponenten und Werkzeuge haben.

Warnung: Legen Sie alle Teile auf eine ebene Fläche. Legen Sie eine weiche Decke oder Ähnliches darunter, um sie vor Kratzern oder Flecken zu schützen. Vermeiden Sie es, Komponenten über den Boden zu ziehen oder zu schieben.

Warnung: Überprüfen Sie regelmäßig alle Beschläge und Befestigungen, um sicherzustellen, dass sie sicher sind und um Unfälle zu vermeiden. Wenn Teile fehlen, kaputt, beschädigt oder abgenutzt sind, verwenden Sie das Produkt nicht weiter, bis es mit vom Hersteller autorisierten Teilen repariert wurde.

Warnung: Lassen Sie Kinder nicht auf die Möbel klettern, da dies zum Umkippen und zu schweren Verletzungen führen kann. Bauen Sie die Möbel außerhalb der Reichweite von Kindern zusammen.

Warnung: Stellen Sie die Möbel nicht in die Nähe von Feuerquellen oder heißen Gegenständen, um Brandgefahr zu vermeiden.

Warnung: Reinigen Sie die Möbel mit einem feuchten Tuch oder Alkohol. Verwenden Sie keine Reinigungsmittel mit ätzenden Chemikalien.

Warnung: Dieses Produkt ist mit einer Kippschutzvorrichtung ausgestattet. Bitte installieren Sie diese Vorrichtung unbedingt, um unnötige Verletzungen durch Umkippen zu vermeiden.

[EN]

Warning: Please read instructions fully before starting assembly. Check you have all the components and tools listed on pages.

Warning: Please place all parts on a flat surface. Place a soft blanket or similar underneath to protect against scratches or stains. Avoid dragging or sliding components across the floor.

Warning: Regularly check all fittings and fastenings to ensure they are secure and to prevent accidents. If any parts are missing, broken, damaged, or worn, discontinue use of the product until repairs have been made using factory authorized parts.

Warning: Do not allow children to climb on the furniture as this may result in tipping and serious personal injury. Assemble the furniture away from the reach of children.

Warning: Do not place furniture close to fire sources or high-temperature objects to avoid the risk of fire.

Warning: Clean furniture with a damp cloth or alcohol, avoid using cleaning agents containing corrosive chemicals.

Warning: This product is equipped with an anti-tilt device. Please be sure to install this device to prevent unnecessary injuries caused by tipping.

[FR]

Avertissement : Veuillez lire entièrement les instructions avant de commencer l'assemblage. Vérifiez que vous disposez de tous les composants et outils répertoriés sur les pages.

Avertissement : Veuillez placer toutes les pièces sur une surface plane. Placez une couverture douce ou similaire en dessous pour les protéger des rayures ou des taches. Évitez de faire glisser les composants sur le sol.

Avertissement : Vérifiez régulièrement tous les raccords et fixations pour vous assurer qu'ils sont bien fixés et pour éviter les accidents. Si des pièces manquent, sont cassées, endommagées ou usées, cessez d'utiliser le produit jusqu'à ce que des réparations aient été effectuées à l'aide de pièces autorisées par l'usine.

Avertissement : Ne laissez pas les enfants grimper sur les meubles car cela pourrait entraîner un basculement et des blessures graves. Assemblez les meubles hors de portée des enfants.

Avertissement : Ne placez pas les meubles à proximité de sources de feu ou d'objets à haute température pour éviter tout risque d'incendie.



Avertissement : Nettoyez les meubles avec un chiffon humide ou de l'alcool, évitez d'utiliser des produits de nettoyage contenant des produits chimiques corrosifs.

Avertissement : Ce produit est équipé d'un dispositif anti-basculement. Assurez-vous d'installer ce dispositif pour éviter les blessures inutiles causées par un basculement.

[IT]

Attenzione: leggere attentamente le istruzioni prima di iniziare il montaggio. Verificare di avere tutti i componenti e gli strumenti elencati nelle pagine.

Attenzione: posizionare tutte le parti su una superficie piana. Posizionare una coperta morbida o simile sotto per proteggere da graffi o macchie. Evitare di trascinare o far scivolare i componenti sul pavimento.

Attenzione: controllare regolarmente tutti i raccordi e i dispositivi di fissaggio per assicurarsi che siano sicuri e per prevenire incidenti. Se alcune parti sono mancanti, rotte, danneggiate o usurate, interrompere l'uso del prodotto fino a quando non siano state eseguite le riparazioni utilizzando parti autorizzate dalla fabbrica.

Attenzione: non consentire ai bambini di arrampicarsi sui mobili poiché ciò potrebbe causare ribaltamenti e gravi lesioni personali. Montare i mobili lontano dalla portata dei bambini.

Attenzione: non posizionare i mobili vicino a fonti di fuoco o oggetti ad alta temperatura per evitare il rischio di incendio.

Attenzione: pulire i mobili con un panno umido o alcol, evitare di utilizzare detergenti contenenti sostanze chimiche corrosive.

Attenzione: questo prodotto è dotato di un dispositivo antiribaltamento. Assicurarsi di installare questo dispositivo per prevenire lesioni inutili causate dal ribaltamento.

[ES]

Advertencia: Lea las instrucciones completamente antes de comenzar el montaje. Compruebe que tiene todos los componentes y herramientas que se enumeran en las páginas.

Advertencia: Coloque todas las piezas sobre una superficie plana. Coloque una manta suave o algo similar debajo para protegerlas de rayones o manchas. Evite arrastrar o deslizar los componentes por el piso.

Advertencia: Verifique regularmente todos los accesorios y fijaciones para asegurarse de que estén seguros y evitar accidentes. Si falta alguna pieza, está rota, dañada o desgastada, deje de usar el producto hasta que se hayan realizado las reparaciones con piezas autorizadas de fábrica.

Advertencia: No permita que los niños se suban a los muebles, ya que esto puede provocar que se vuelquen y lesiones personales graves. Monte los muebles fuera del alcance de los niños.

Advertencia: No coloque los muebles cerca de fuentes de fuego u objetos de alta temperatura para evitar el riesgo de incendio.

Advertencia: Limpie los muebles con un paño húmedo o alcohol, evite usar agentes de limpieza que contengan químicos corrosivos.

Advertencia: Este producto está equipado con un dispositivo antivuelco. Asegúrese de instalar este dispositivo para evitar lesiones innecesarias causadas por vuelcos.

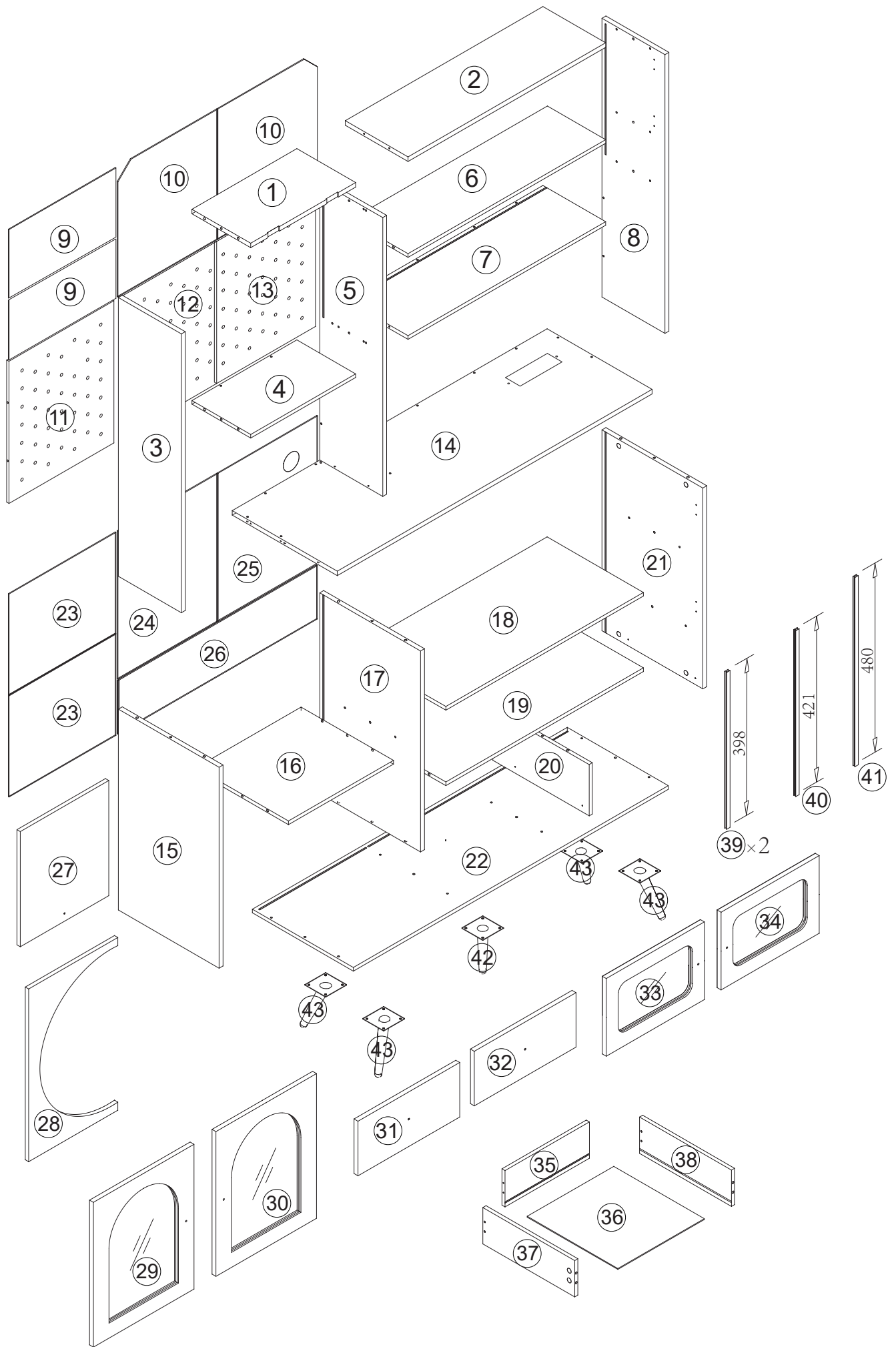

N620P386804/N639P386889

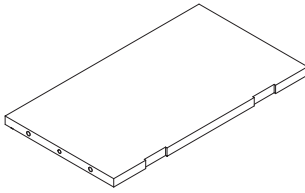
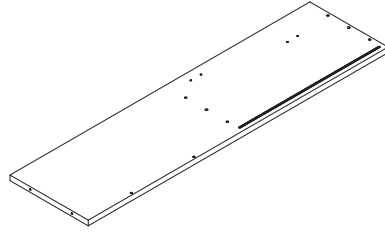
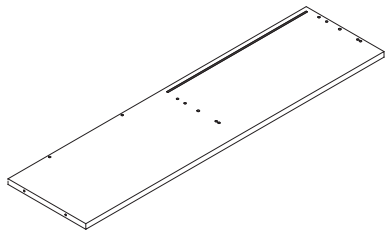
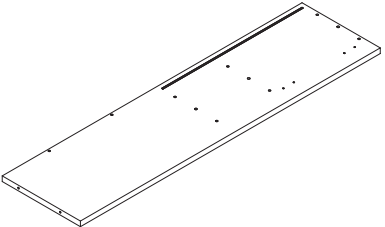
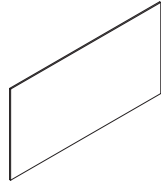
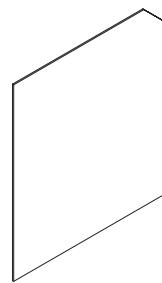
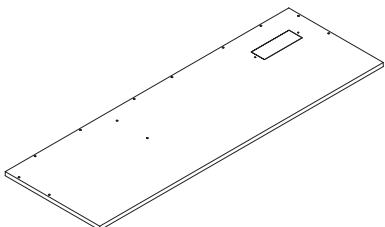
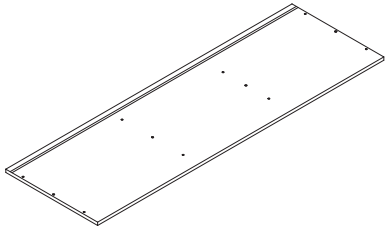
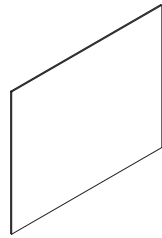
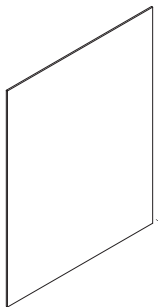
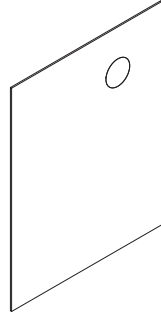
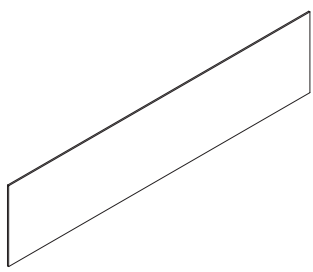
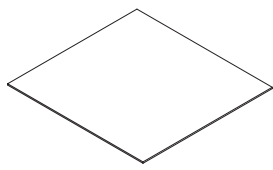
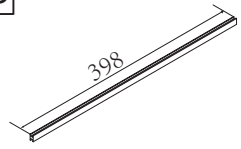
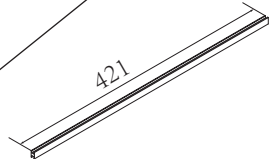
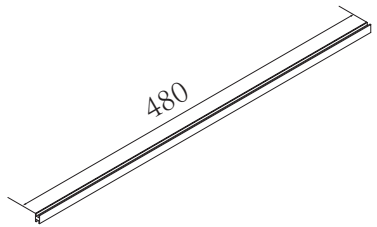
<p>1</p>  <p>1PC</p>	<p>3</p>  <p>1PC</p>	<p>5</p>  <p>1PC</p>
<p>8</p>  <p>1PC</p>	<p>9</p>  <p>2PC</p>	<p>10</p>  <p>2PC</p>
<p>14</p>  <p>1PC</p>	<p>22</p>  <p>1PC</p>	<p>23</p>  <p>2PCS</p>
<p>24</p>  <p>2PCS</p>	<p>25</p>  <p>1PC</p>	<p>26</p>  <p>1PC</p>
<p>36</p>  <p>2PCS</p>	<p>39</p>  <p>2PCS</p> <p>40</p>  <p>1PC</p>	<p>41</p>  <p>1PC</p>

N620P386805/N639P386890

2

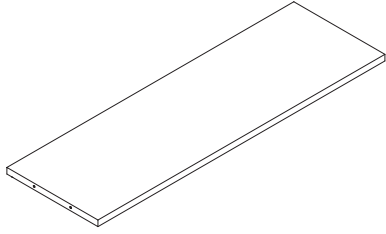

1PC

4

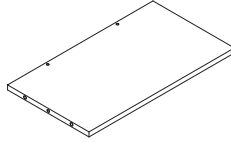

1PC

6

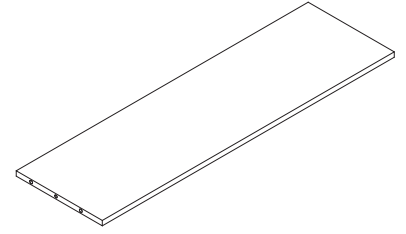

1PC

7

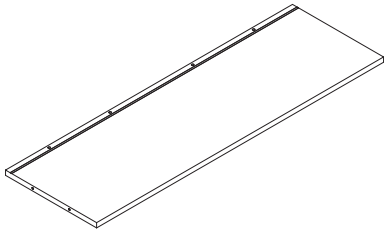

1PC

15

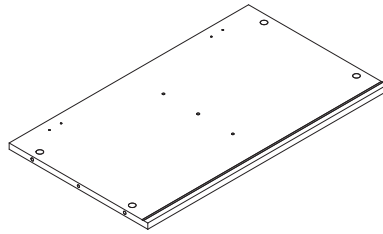

1PC

17

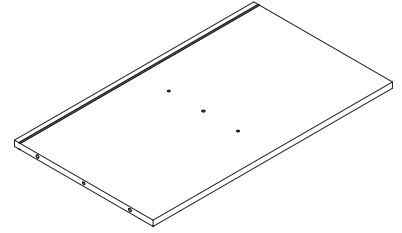

1PC

19

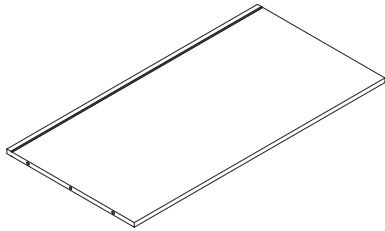

1PC

20

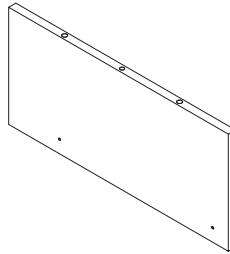

1PCS

21

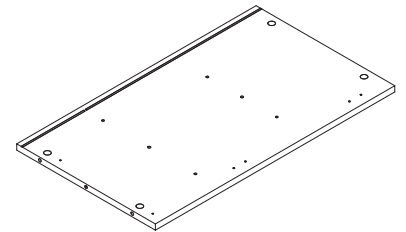

1PCS

35

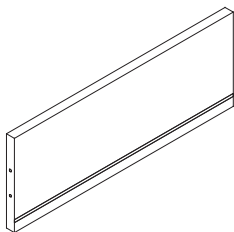

2PC

37

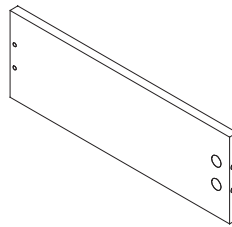

2PC

38

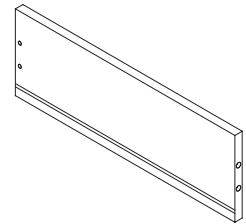

2PC

N620P386806/N639P386891

11

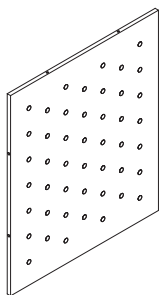

1PC

12

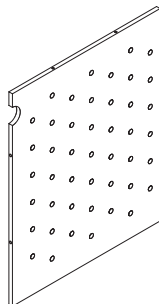

1PC

13

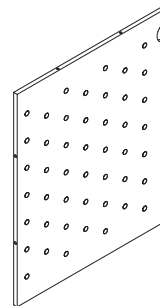

1PC

16

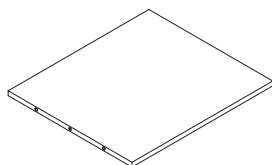

1PC

18

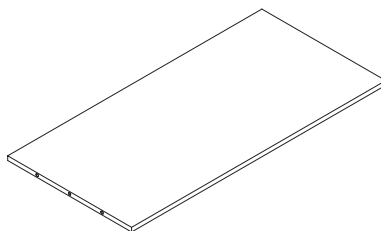

1PC

27

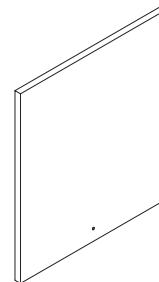

1PC

28

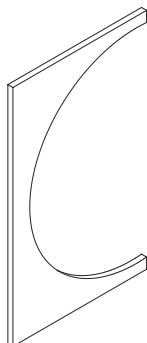

1PC

29

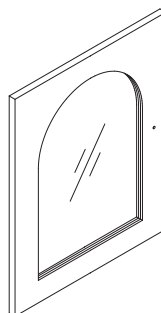

1PC

30

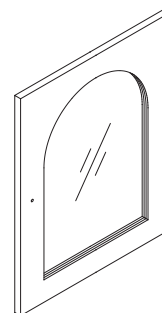

1PC

31

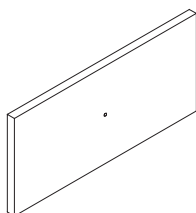

2PCS

32

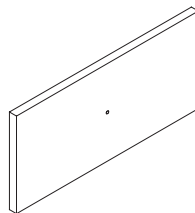

3PCS

33

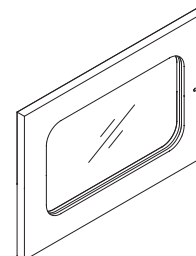

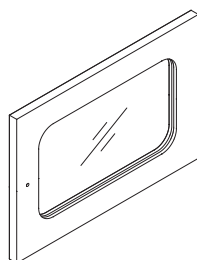

3PCS

34

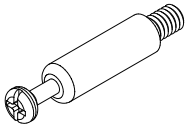
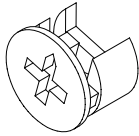
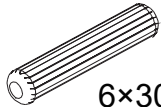
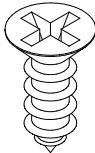
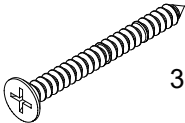
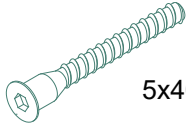
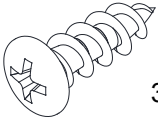
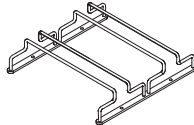
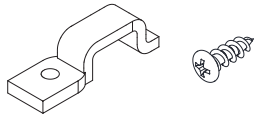

3PCS

N620P386806/N639P386891

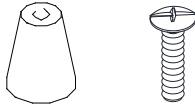
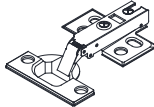
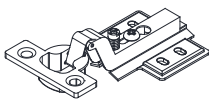
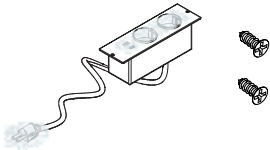
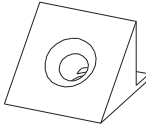
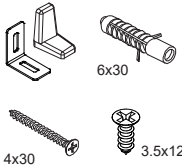
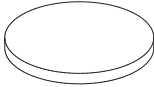
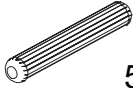
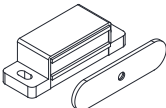
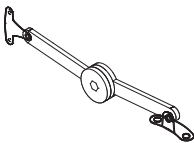
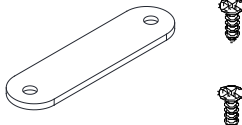
<p>A</p>  <p>52PCS</p>	<p>B</p>  <p>52PCS</p>	<p>C</p>  <p>6×30</p> <p>25PCS</p>
<p>D</p>  <p>3.5×14</p> <p>138PCS</p>	<p>E</p>  <p>3.5×35mm</p> <p>20PCS</p>	<p>F</p>  <p>5×40mm</p> <p>10PCS</p>
<p>G</p>  <p>3.5×12</p> <p>4PCS</p>	<p>H</p>  <p>1PCS</p>	<p>I</p>  <p>3PCS</p>
<p>J</p>  <p>1PCS</p>	<p>K</p>  <p>7PCS</p>	<p>L</p>  <p>6PCS</p>
<p>M</p>  <p>4PCS</p>	<p>N</p>  <p>1PCS</p>	<p>O</p>  <p>26PC</p>
<p>P</p>  <p>4×30</p> <p>6×30</p> <p>3.5×12</p> <p>2PC</p>	<p>Q</p>  <p>52PCS</p>	<p>R</p>  <p>5×30</p> <p>10PC</p>
<p>S</p>  <p>1PC</p>	<p>T</p>  <p>1PC</p>	<p>U</p>  <p>2PC</p>

N620P386806/N639P386891

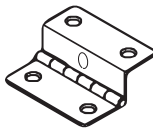
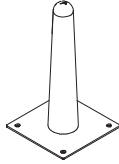
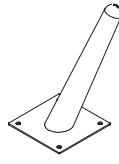
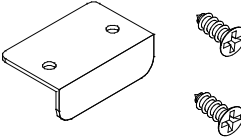
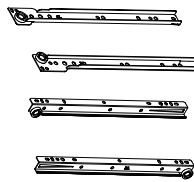
<p>V</p>  <p>2PCS</p>	<p>W</p>  <p>1PCS</p>	<p>X</p>  <p>4PCS</p>
<p>Y</p>  <p>1PCS</p>	<p>350mm</p>  <p>2PC</p>	

Importeur	Decobus Handel GmbH
Adresse	Innungsstraße 9, 21244 Buchholz, Deutschland
URL	https://www.decobusgroup.de
Hersteller	Shouguang Easy Wood Co., Ltd.
Adresse	The Intersection of Yuanfeng Street and Xingan Road, Anjia Village, Gucheng Subdistrict, Shouguang City.
Email/URL	<Hill@sgeasywood.com>
Partienummer	N620P386804/N620P386805/N620P386806
Hergestellt in	CHINA
EC REP	Decobus Handel GmbH Innungsstraße 9, 21244 Buchholz, Deutschland https://www.decobusgroup.de

Importer	COMHARBOR LIMITED
Add	Unit C, Swift Point, Cosford Lane, Rugby, CV21 1PY, GB
Email/URL	harborcomhar@gmail.com
Manufacturer	Shouguang Easy Wood Co., Ltd.
Add	The Intersection of Yuanfeng Street and Xingan Road, Anjia Village, Gucheng Subdistrict, Shouguang City.
Email/URL	<Hill@sgeasywood.com>
Product identification	N639P386889/N639P386890/N639P386891
Made in	CHINA
UK REP	COMHARBOR LIMITED Unit C, Swift Point, Cosford Lane, Rugby, CV21 1PY, GB harborcomhar@gmail.com

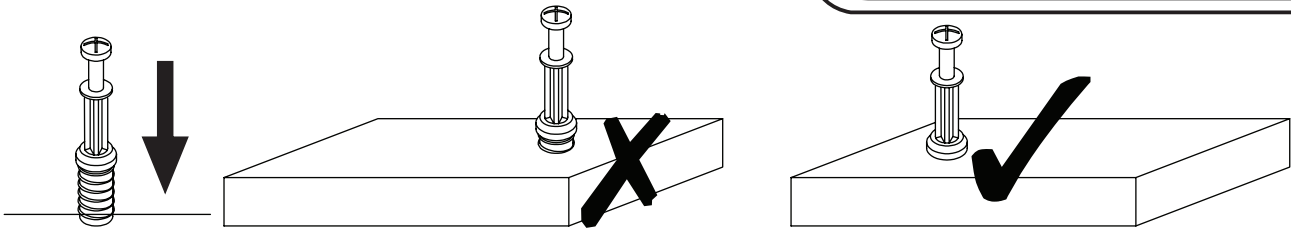

EN_QUICKFIT: Tighten quickfit until shoulder is flush with panel. Do not overtighten or undertighten.

FR_RACCORD RAPIDE: Faites serrer le raccord rapide jusqu'à ce que l'épaulement soit parfaitement encastré dans le panneau. Il ne faut ni trop serrer ni insuffisamment serrer.

ES_QUICKFIT: Apriete quickfit hasta que el hombro se descargue con el panel. NO lo sobreapriete ni lo apriete poco.

DE_QUICKFIT: Ziehen Sie den Quickfit fest, bis die Schulter mit der Platte bündig ist. Bitte nicht zu fest oder zu schwach anziehen.

IT_MONTAGGIO RAPIDO: Stringere il montaggio rapido fino a quando la spalla è a filo con il pannello, non stringere troppo o troppo poco.

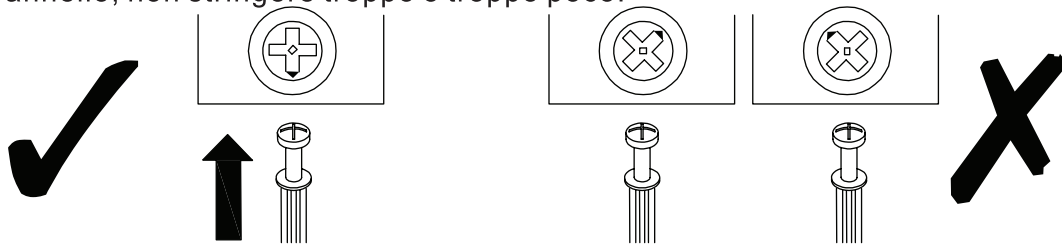

EN_CAM LOCK: When fitting cam lock, ensure starting position is correct before you insert connecting quickfit.

FR_SERRURE BATTEUSE: Avant d'insérer la serrure batteuse, veillez à la bonne orientation avant d'insérer le raccord rapide.

ES_CIERRE DE LA CÁMARA: Cuando instale el cierre de la cámara, asegúrese de que la posición de inicio es correcta antes de que inserte el quickfit conector.

DE_CAM-LOCK: Achten Sie bei der Montage des Cam-Locks auf die richtige Ausgangsposition, bevor Sie den Quickfit einsetzen.

IT_BLOCCAGGIO A CAMMA: Quando si monta il bloccaggio a camma, assicurarsi che la posizione iniziale sia corretta prima di inserire il montaggio rapido di collegamento.

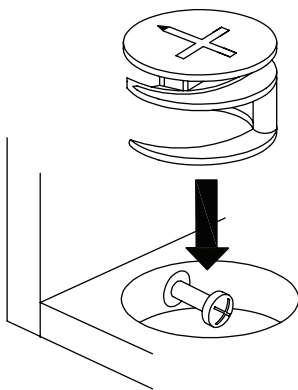

EN_Quickfit head should be in the centre of the cam lock when the two panels are joined.

Cam lock should be inserted before quickfit.

FR_Lorsque les deux panneaux sont assemblés, la tête du raccord rapide doit reposer au centre de la serrure batteuse. Il faut insérer la serrure batteuse avant le raccord rapide.

ES_El cabezal del quickfit debe estar en el centro del cierre de la cámara cuando se unan los dos paneles.

Se debe insertar el cierre de la cámara antes que el quickfit.

DE_Der Quickfit-Kopf sollte sich in der Mitte des Cam-Locks befinden, wenn die beiden Platten zusammengefügt sind. Der Cam-Lock sollte vor dem Quickfit eingesetzt werden.

IT_La testa del montaggio rapido deve trovarsi al centro del bloccaggio a camma quando i due pannelli sono uniti.

Il Bloccaggio a Camma deve essere inserito prima del montaggio rapido.

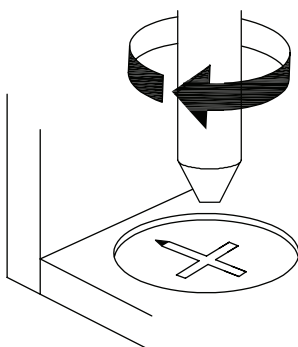

EN_Turn cam lock clockwise to tighten.

FR_Faites tourner la serrure batteuse dans le sens des aiguilles d'une montre pour la resserrer.

ES_Gire el cierre de la cámara en sentido horario para apretarlo.

DE_Drehen Sie den Cam-Lock im Uhrzeigersinn, um ihn festzuziehen.

IT_Ruotare il bloccaggio a camma in senso orario per stringere.

EN It may be necessary to adjust the hinges so that the doors align. Use the instructions below as a guide.

FR Il est parfois nécessaire d'ajuster les charnières pour un meilleur alignement des portes. Servez-vous des instructions ci-dessous comme guide.

ES Puede que sea necesario ajustar los quicios de forma que se alineen las puertas. Use las instrucciones que aparecen debajo como guía.

DE Möglicherweise müssen Sie die Scharniere so einstellen, dass die Türen ausgerichtet sind. Verwenden Sie die nachstehenden Anweisungen als Leitfaden.

IT Potrebbe essere necessario regolare le cerniere in modo che le porte siano allineate. Per fare ciò attenersi alle istruzioni sottostanti.

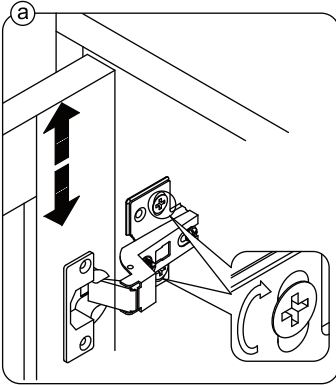

EN To adjust the door vertically loosen the screw as shown and move up and down as needed.

FR Si vous souhaitez régler la porte **verticalement**, desserrez la vis comme indiqué et déplacez la porte de haut en bas selon les besoins.

ES Para ajustar la puerta **verticalmente** afloje el tornillo tal y como se muestra y muévelo hacia arriba o hacia abajo según sea necesario.

DE Um die Tür **vertikal** auszurichten, lösen Sie die Schraube wie abgebildet und bewegen Sie sie nach Bedarf nach oben oder nach unten.

IT Per allineare la porta **verticalmente** allentare la vite come mostrato e spostarla in alto o in basso secondo necessità.

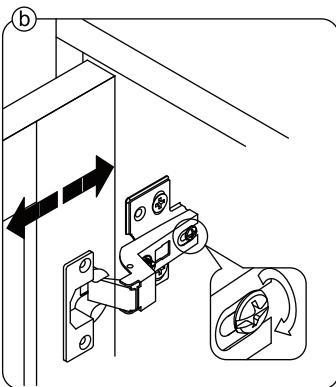

EN To adjust the gap from the door to the main frame turn the screw clockwise or anti-clockwise as needed.

FR Si vous souhaitez ajuster l'**écart** entre la porte et le cadre principal, tournez la vis dans le sens des aiguilles d'une montre ou dans le sens inverse, si nécessaire.

ES Para ajustar el **espacio** desde la puerta al marco principal, gire el tornillo en sentido horario o antihorario, según se necesite.

DE Um den **Abstand** von der Tür zum Hauptrahmen auszurichten, drehen Sie die Schraube je nach Bedarf im oder gegen den Uhrzeigersinn.

IT Per regolare lo **spazio** tra la porta e il telaio principale, avvitare o svitare la vite secondo necessità.

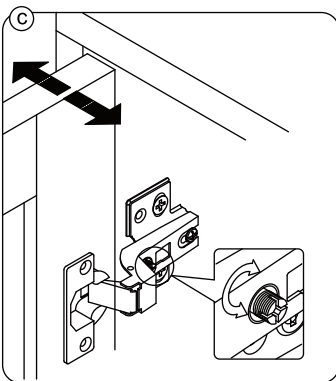

EN To adjust the door laterally adjust the screw as shown by turning clockwise or anti-clockwise.

FR Si vous souhaitez ajuster la porte **latéralement**, ajustez la vis comme indiqué en tournant dans le sens des aiguilles d'une montre ou dans le sens inverse des aiguilles d'une montre.

ES Para ajustar la puerta **lateralmente** ajuste el tornillo tal y como se muestra girándolo en sentido horario y antihorario.

DE Um die Tür **seitlich** auszurichten, stellen Sie bitte die Schraube wie abgebildet durch Drehen im oder gegen den Uhrzeigersinn ein.

IT Per allineare la porta **lateralmente** regolare la vite come mostrato, avvitarandola o svitandola.

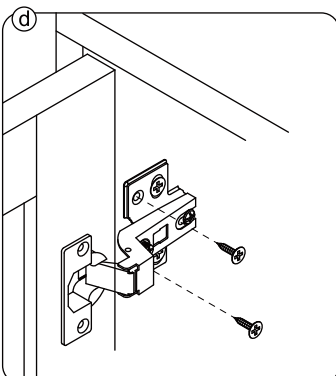

EN Please fix other screws

FR Merci de serrer les autres vis.

ES Fije los demás tornillos

DE Befestigen Sie bitte die anderen Schrauben

IT Fissare le altre viti

1

Ax10PCS

Dx4PCS

Sx1PCS

Tx1PCS

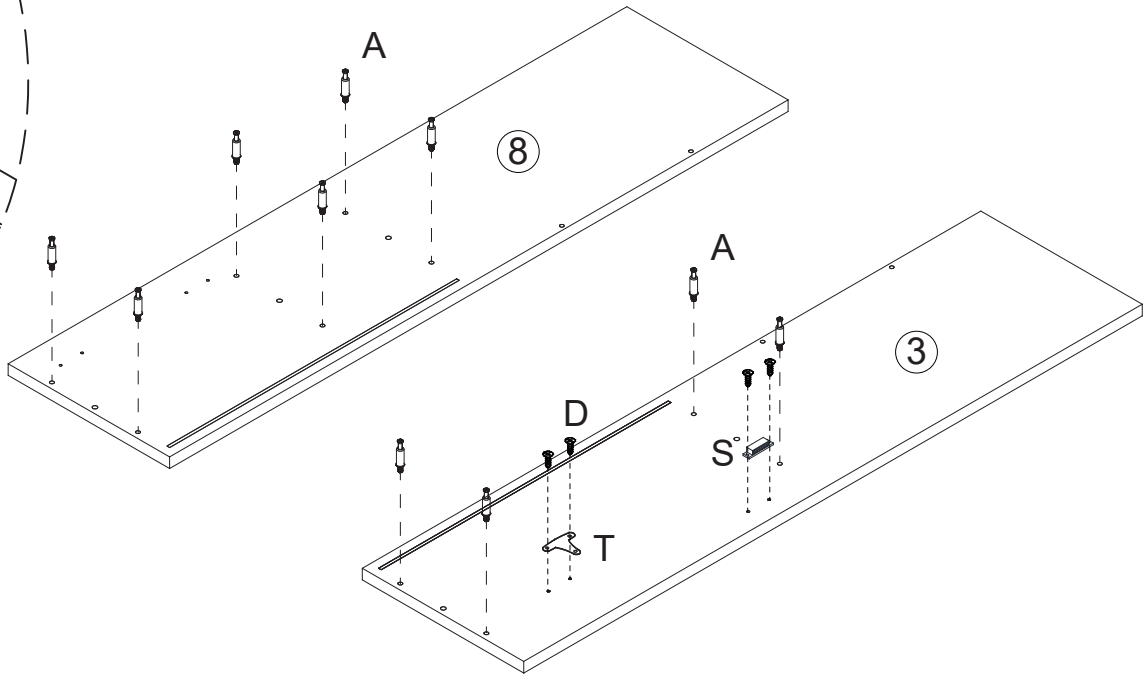
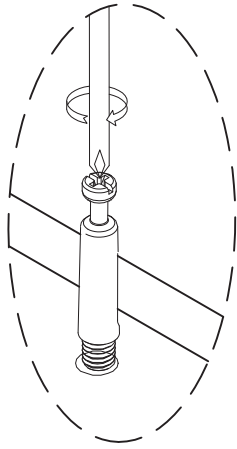

2

Ax6PCS

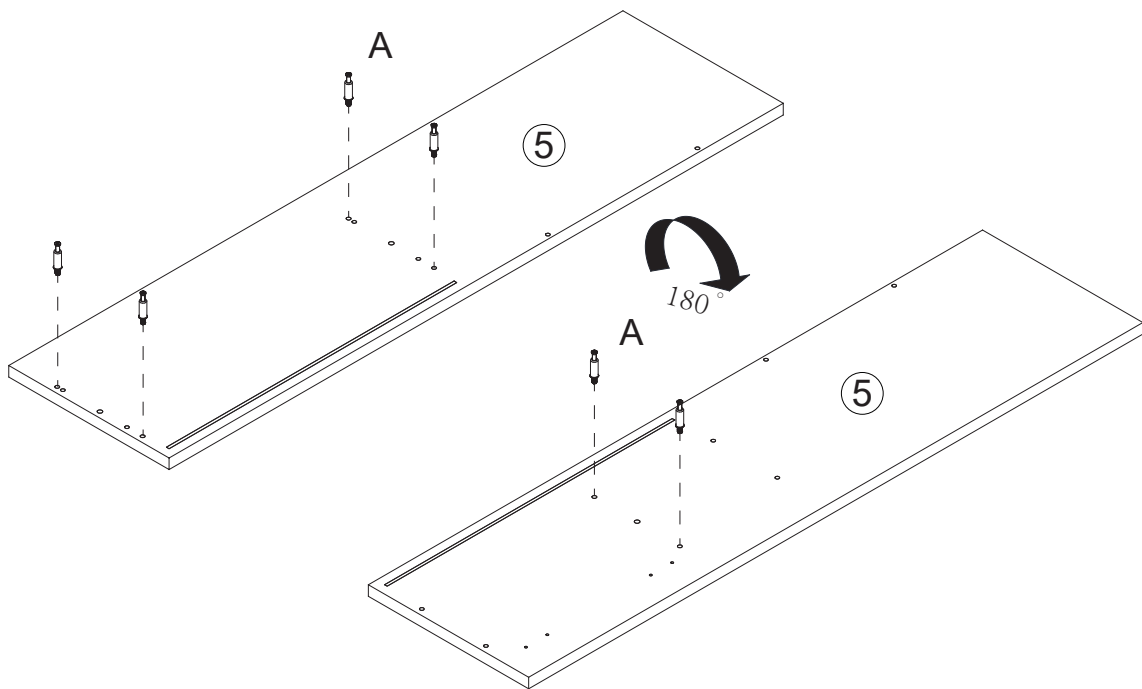

3



Bx6PCS

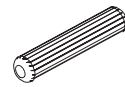

Cx3PCS

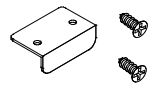

Yx1PCS

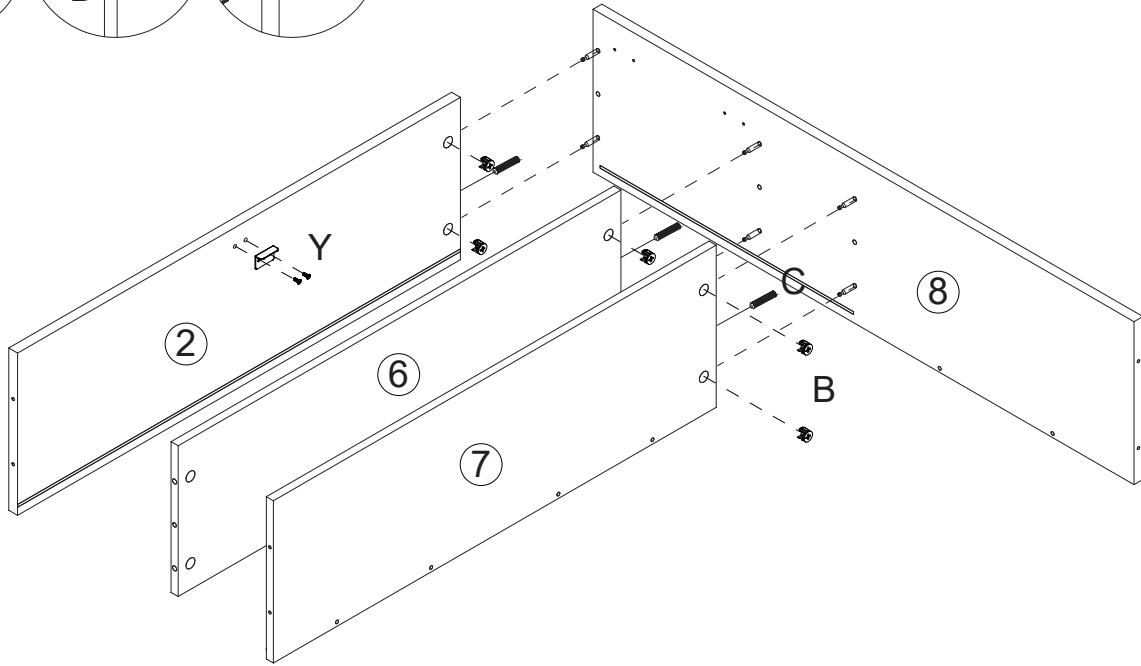
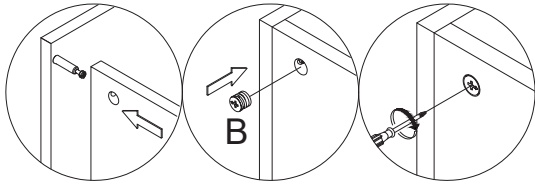

4

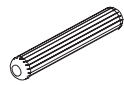

Rx2PCS

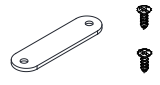

Ux2PCS

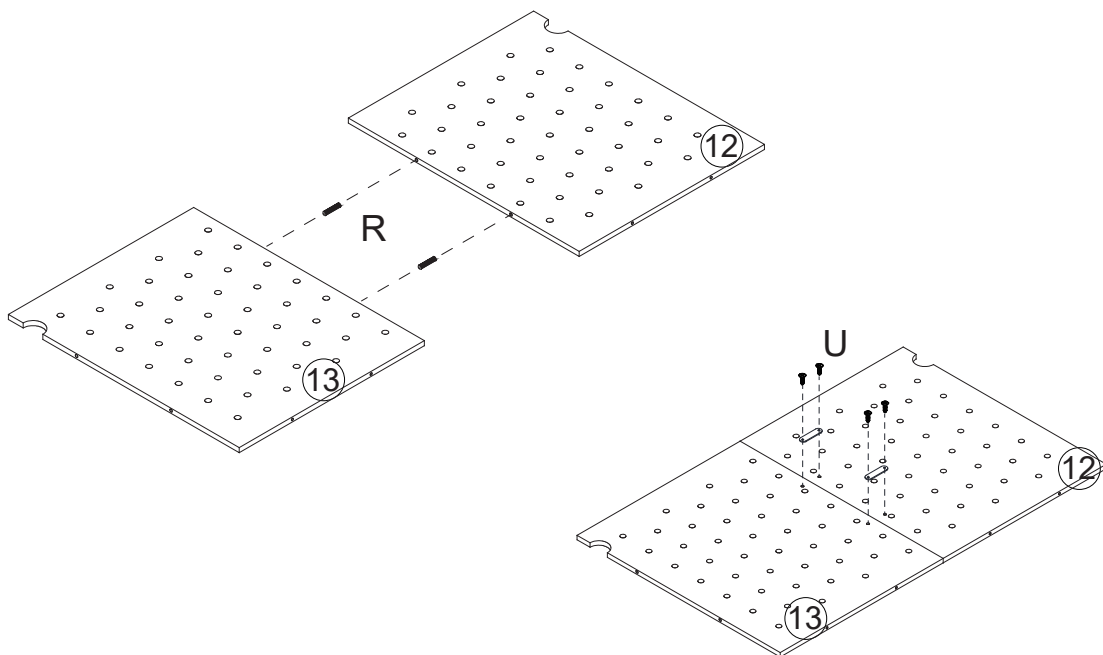

5

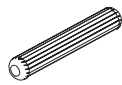

Rx2PCS

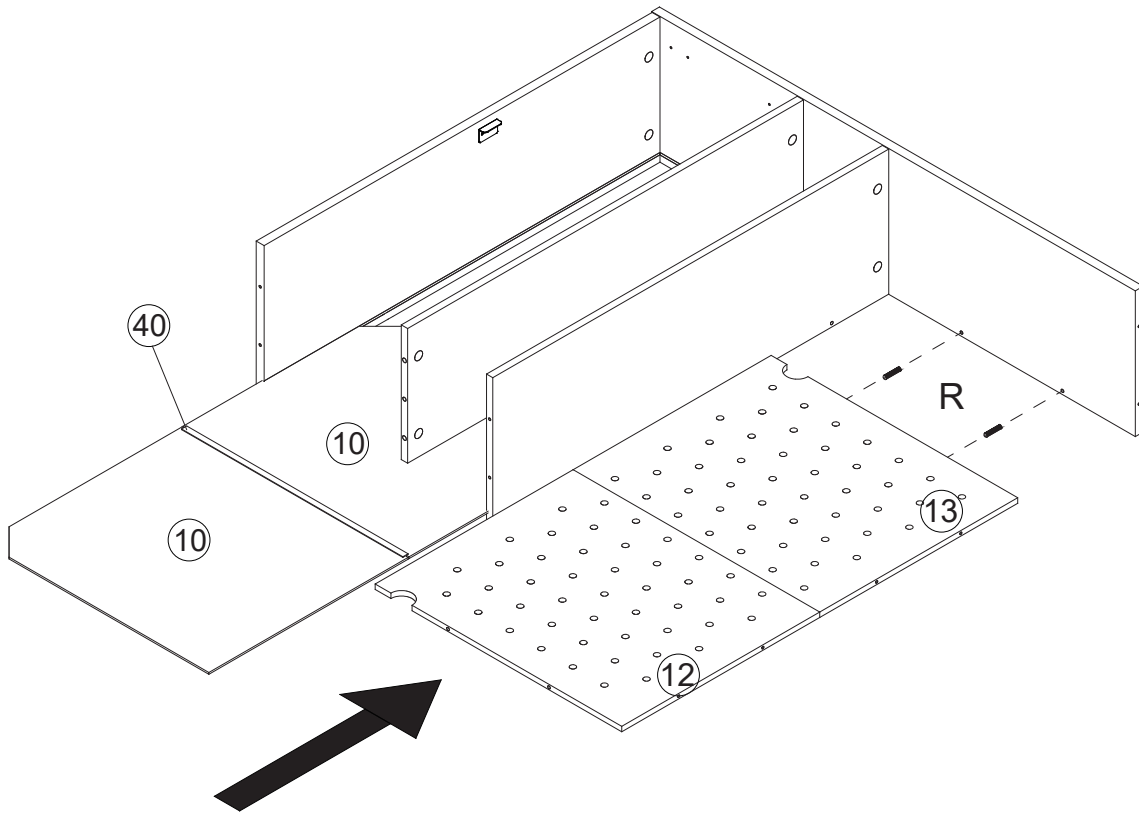

6



Bx2PCS

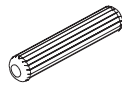

Cx1PCS

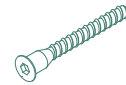

Fx4PCS

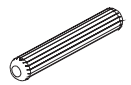

Rx2PCS

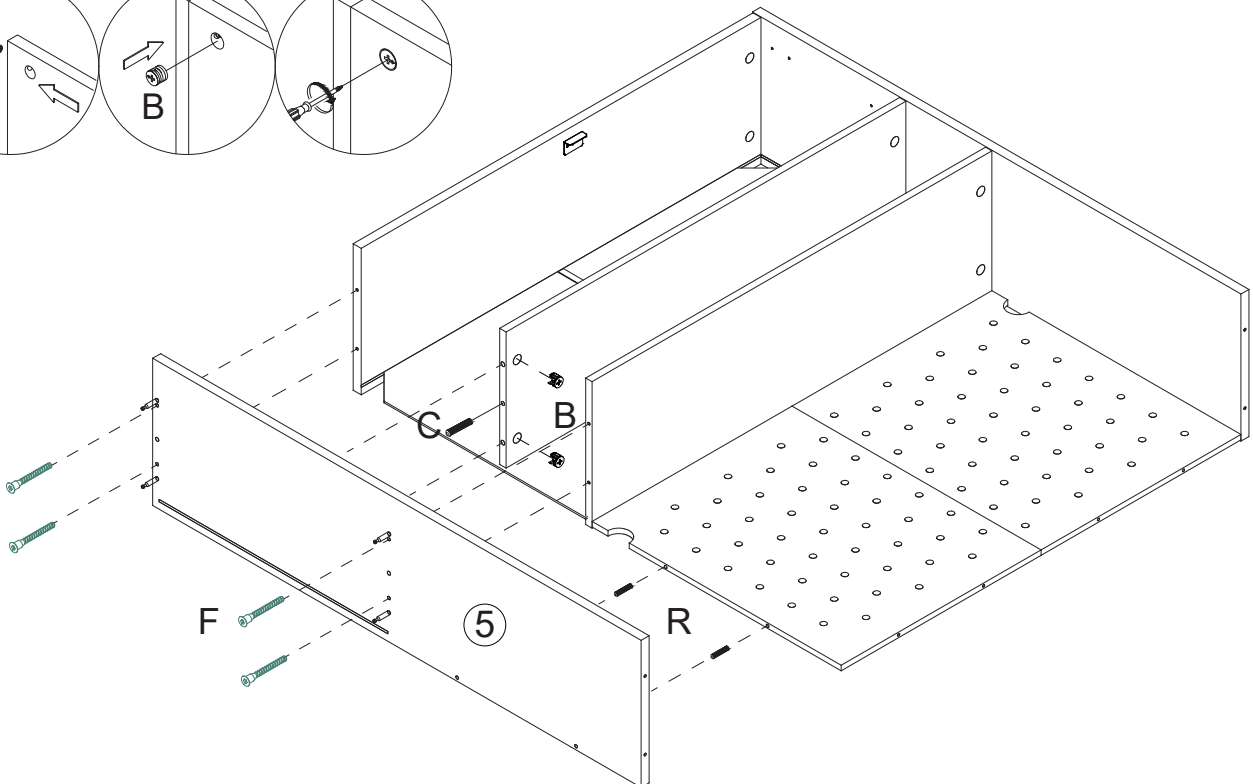
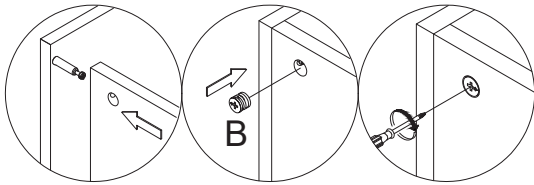

7

Bx4PCS

Cx2PCS

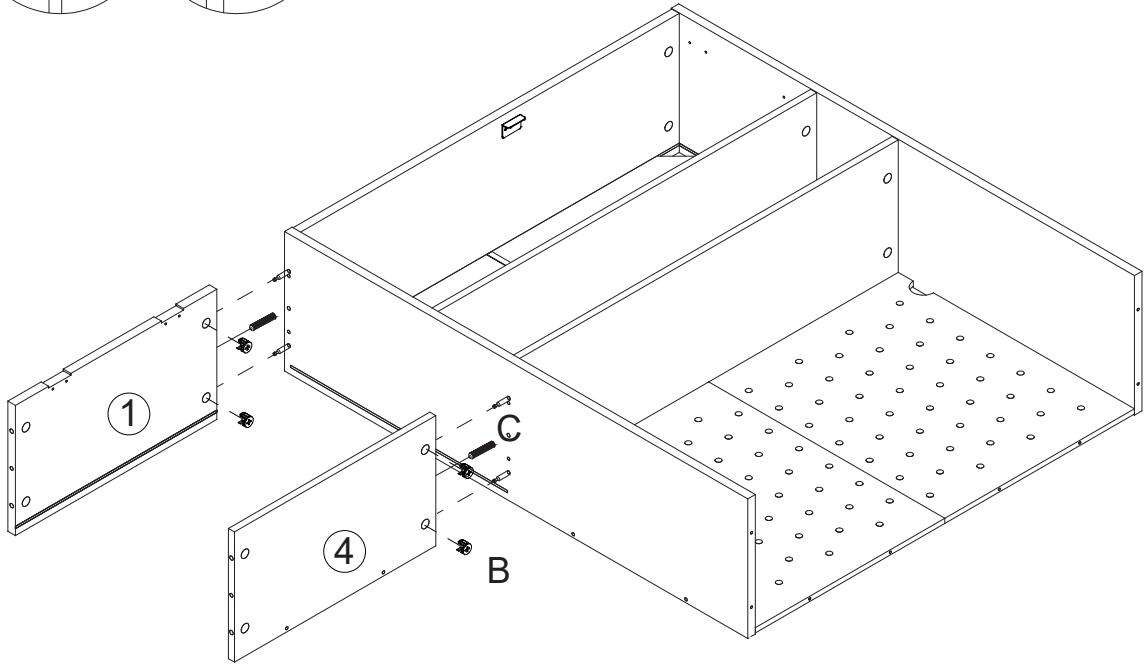
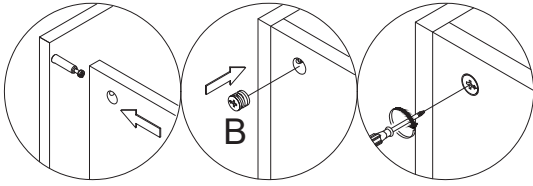

8

Rx2PCS

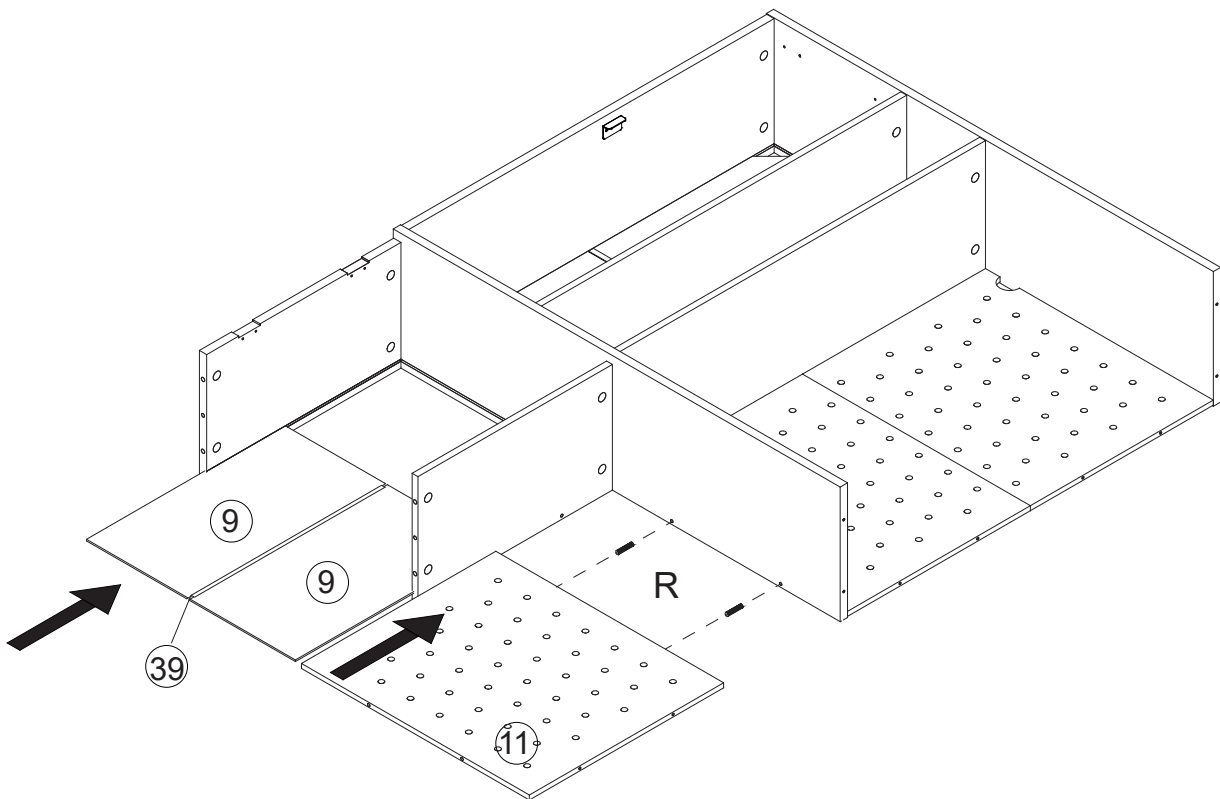

9



Bx4PCS

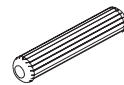

Cx2PCS

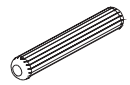

Rx2PCS

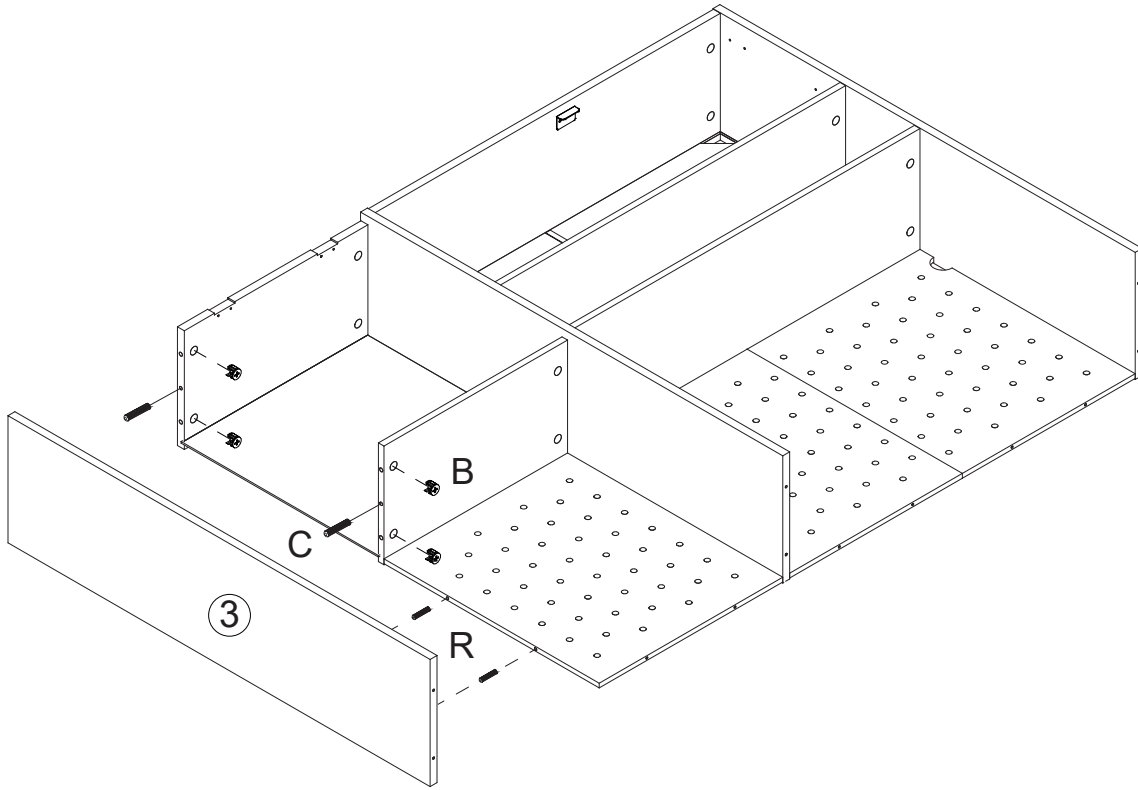

10

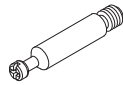

Ax6PCS



Gx4PCS



Hx1PCS

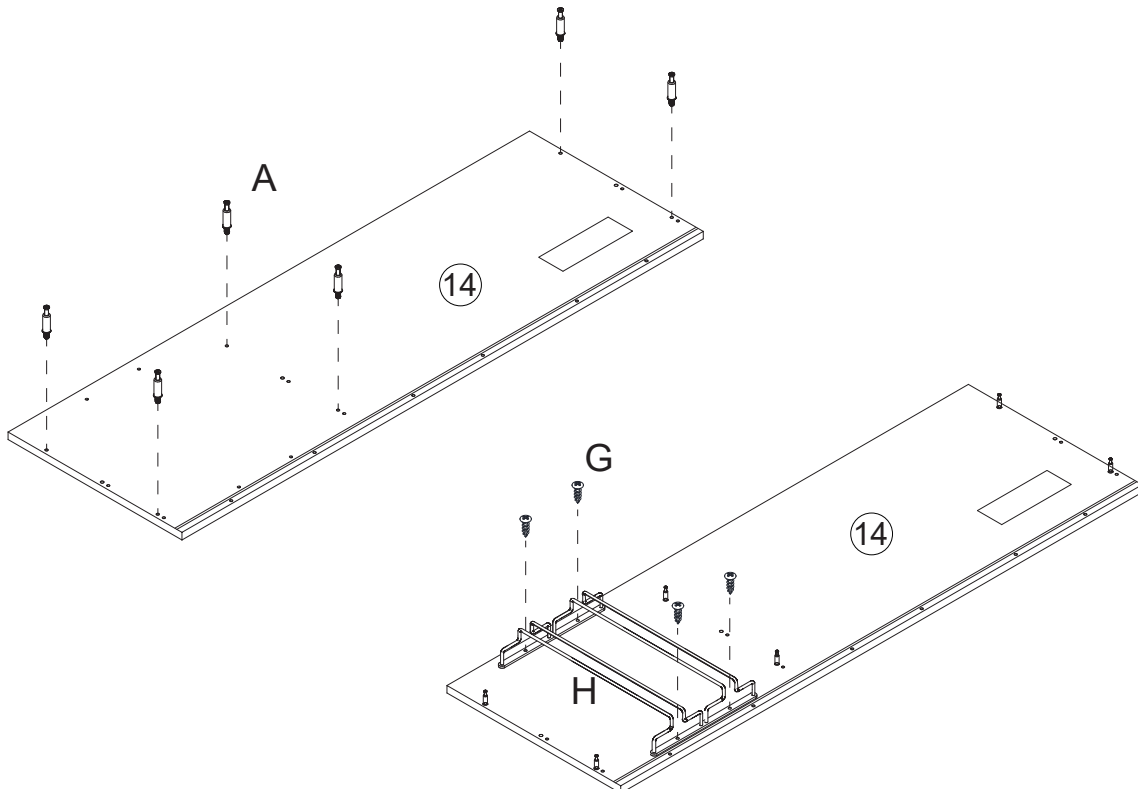

11



Cx3PCS

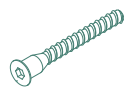

Fx6PCS



Ex6PCS

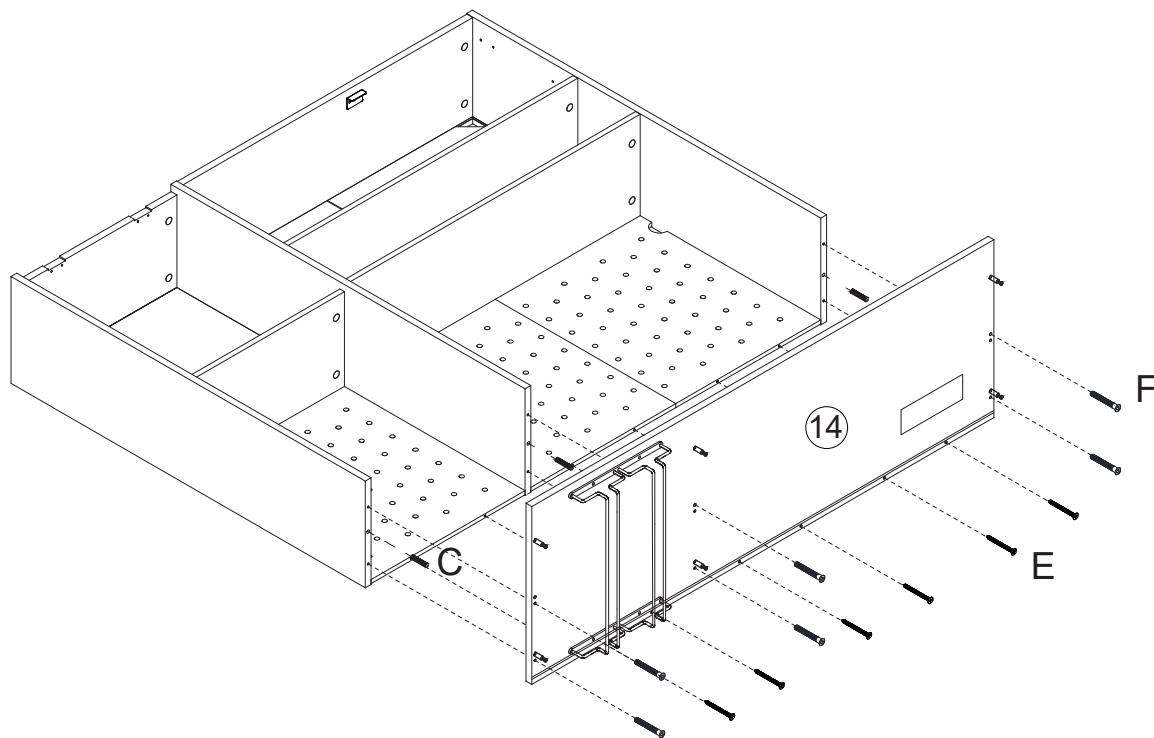

12

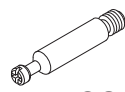

Ax6PCS

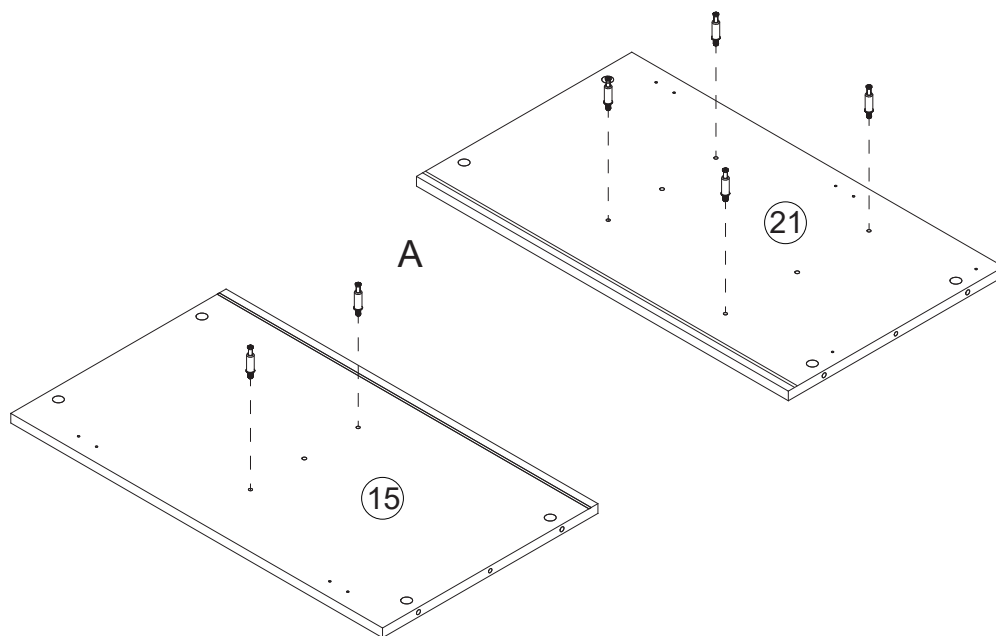

13

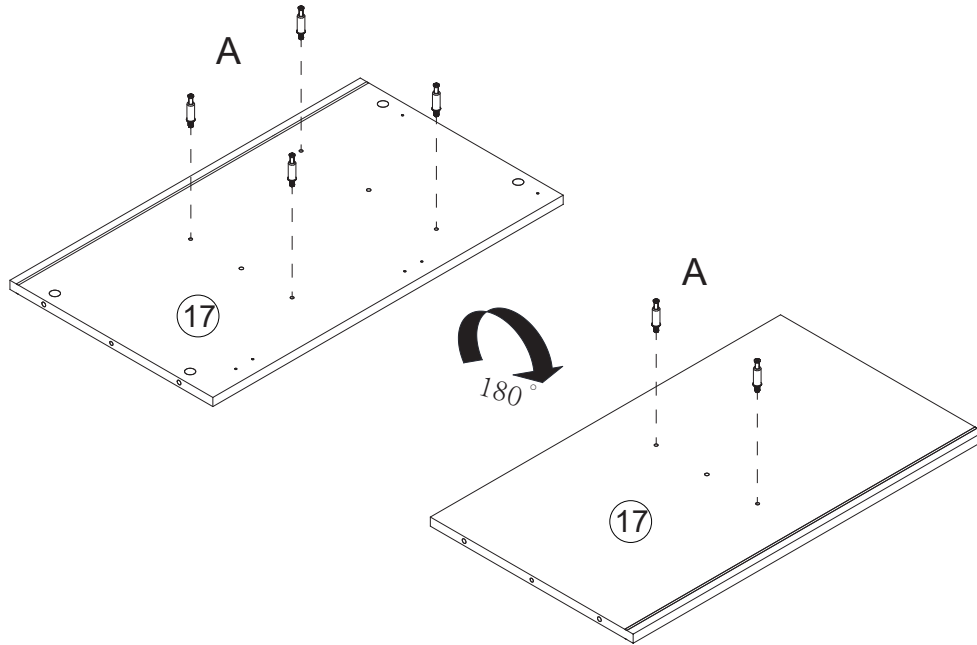

14

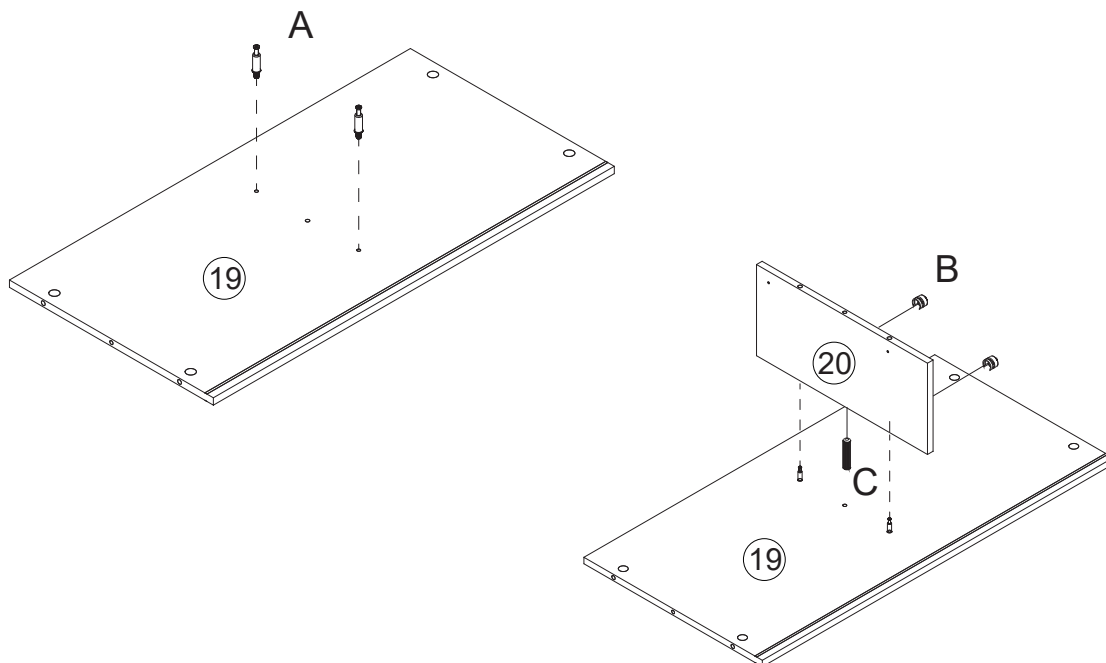

15



Bx4PCS

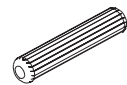

Cx2PCS

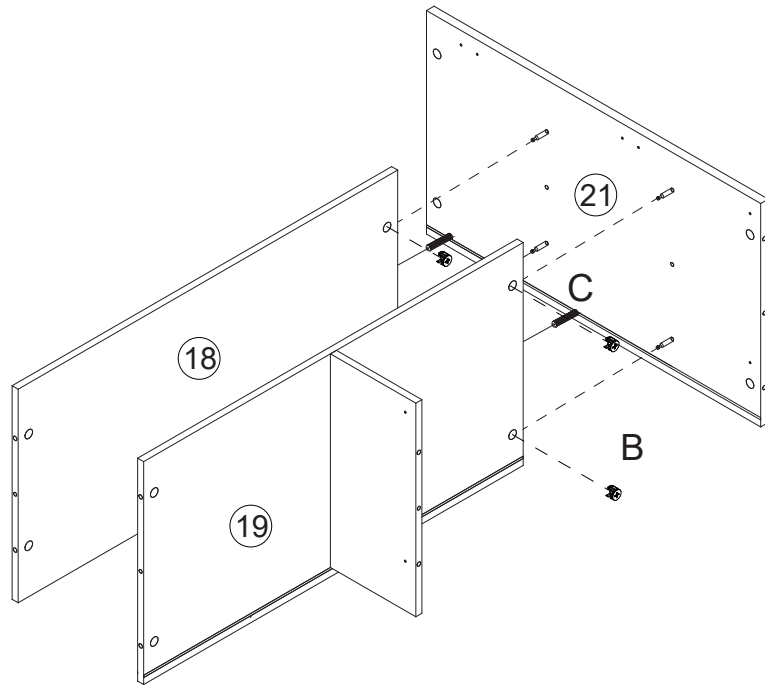

16



Bx4PCS

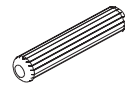

Cx2PCS

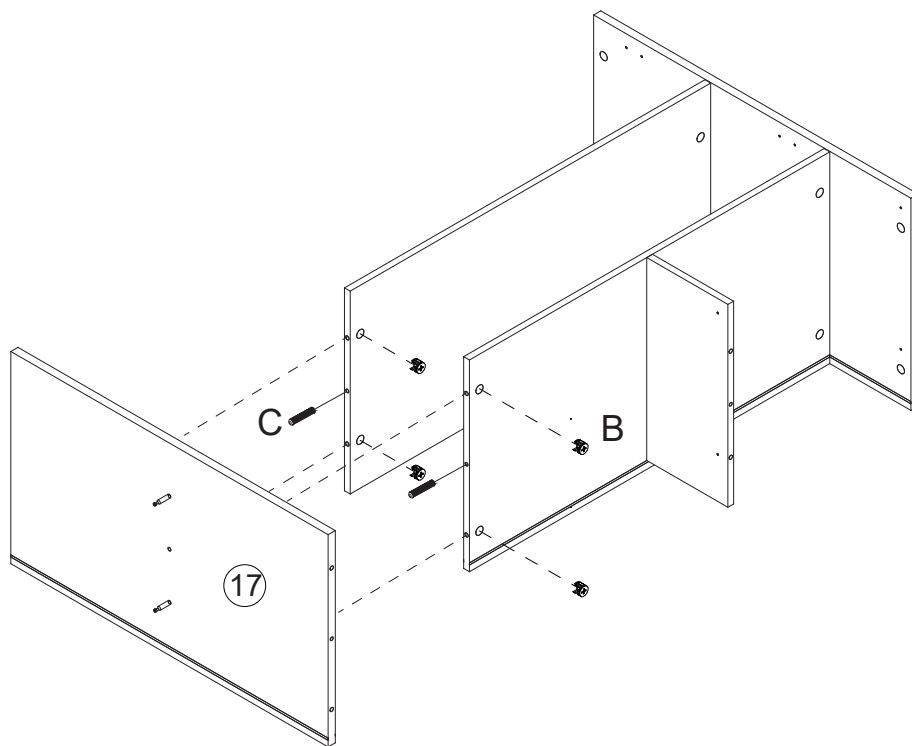

17



Bx2PCS

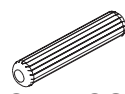

Cx1PCS

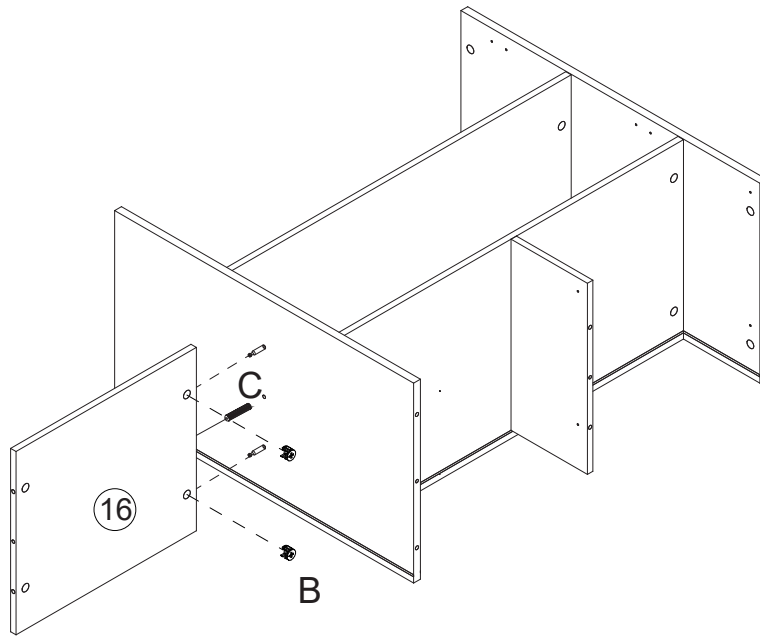

18



Bx2PCS



Cx1PCS

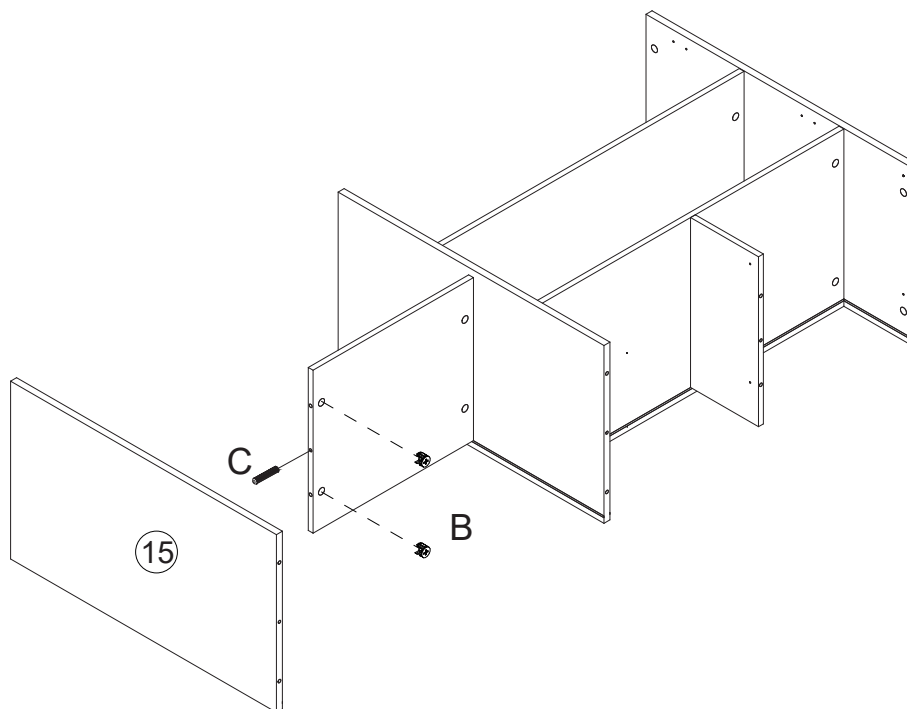

19

Ax8PCS

Dx20PCS

Wx1PCS

Xx4PCS

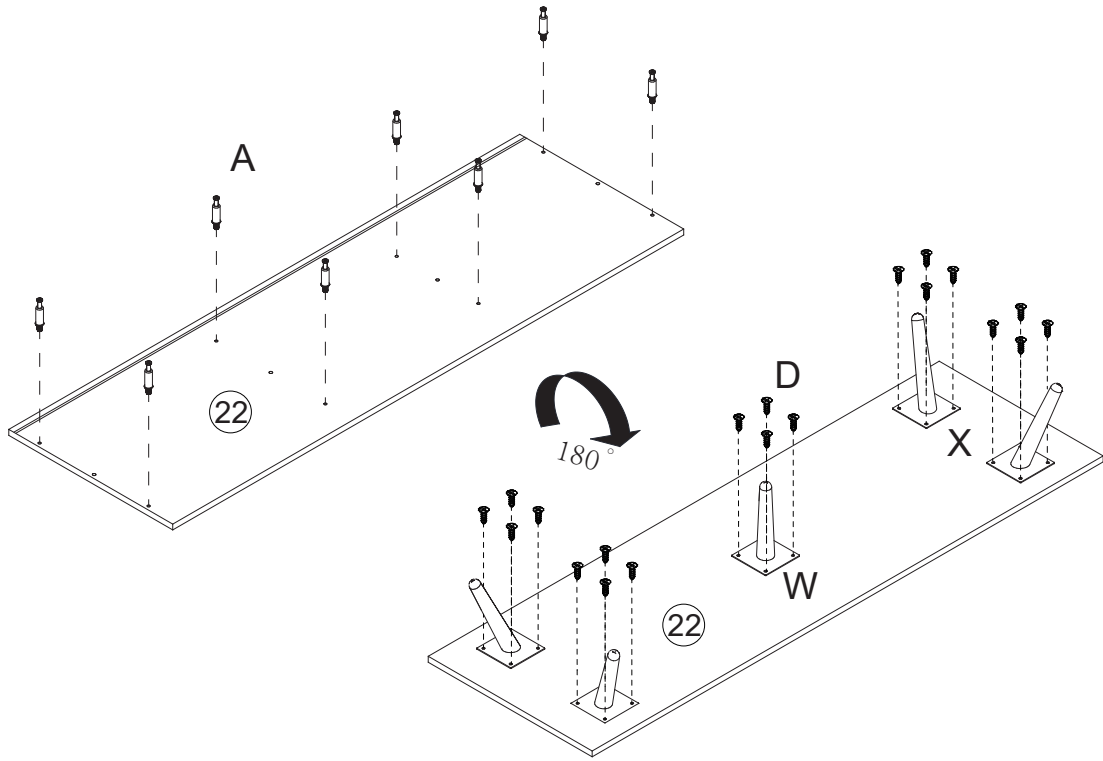

20

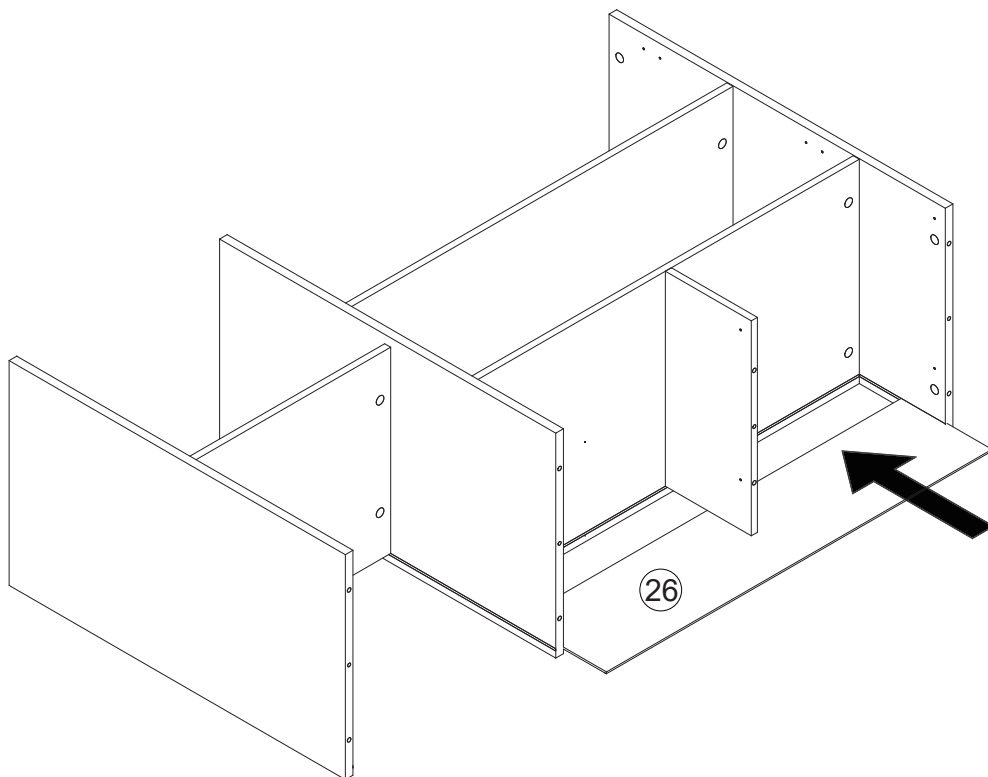

21



Bx8PCS

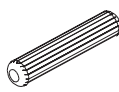

Cx4PCS

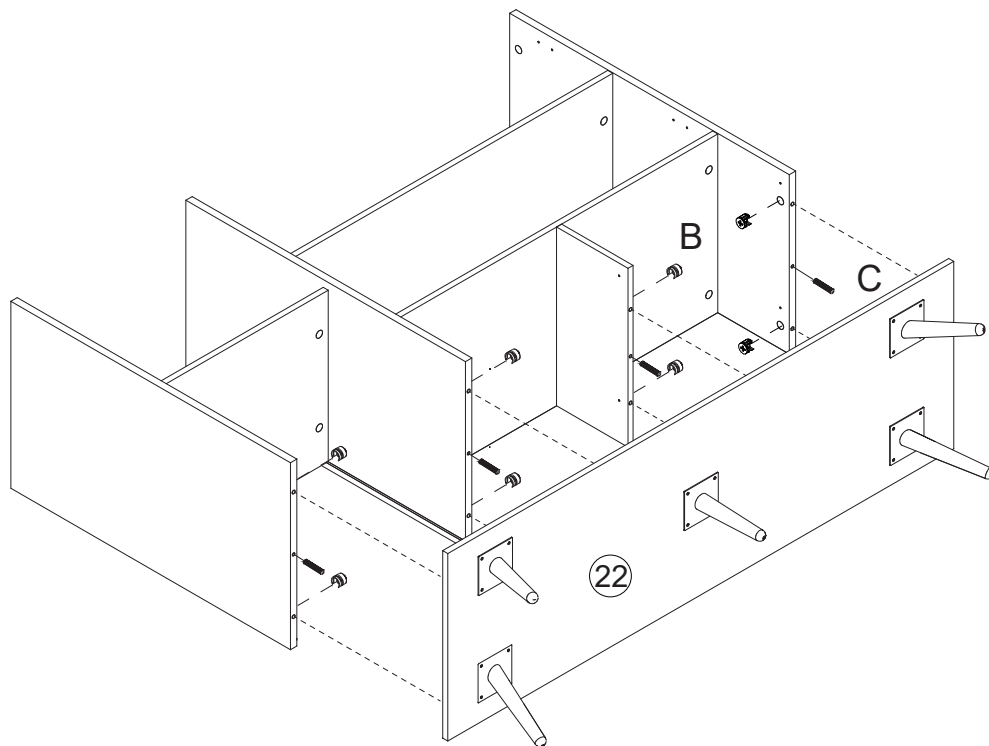

22



Dx8PCS

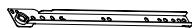

CLx2



CRx2

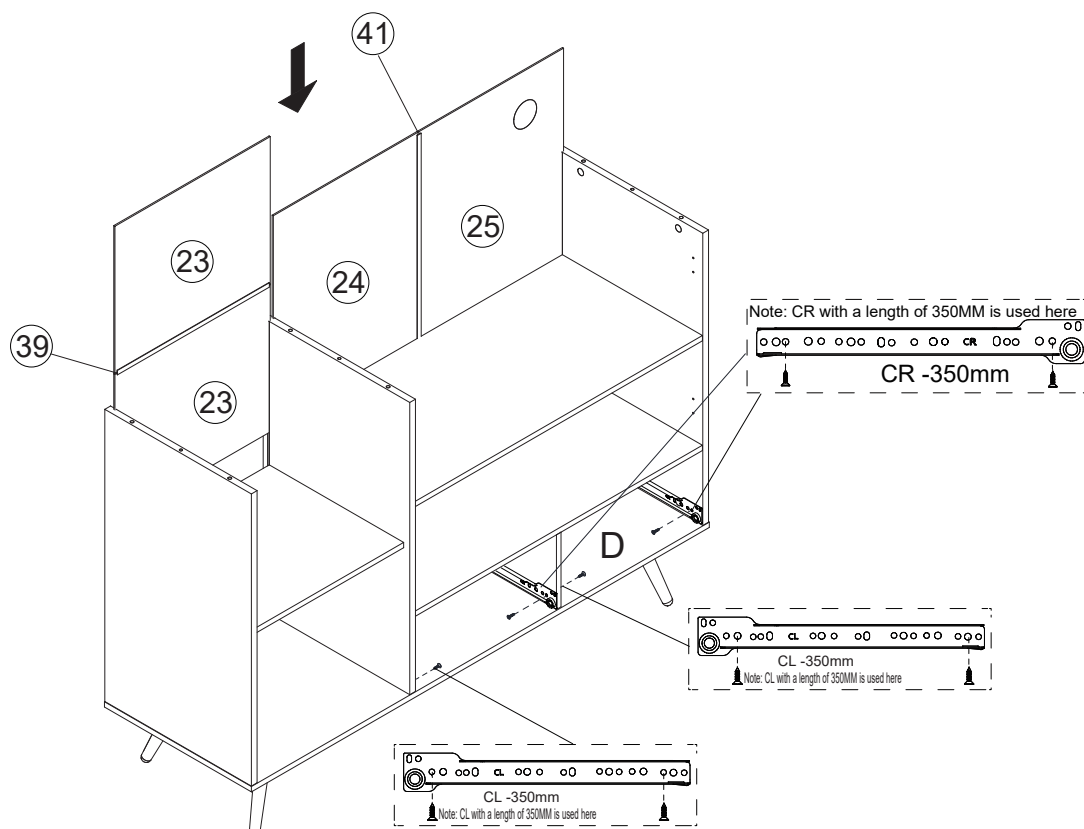

23



Bx6PCS



Cx3PCS

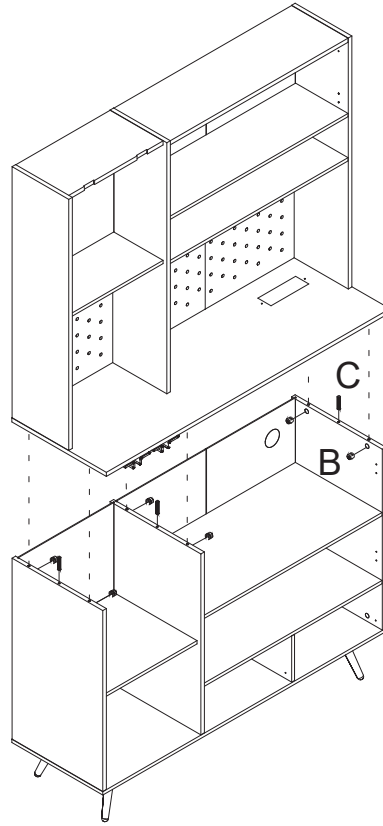

24

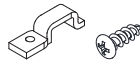

Ix3PCS



Jx1PC



Nx1PC

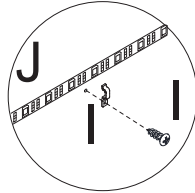
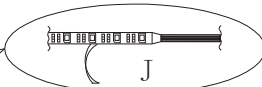
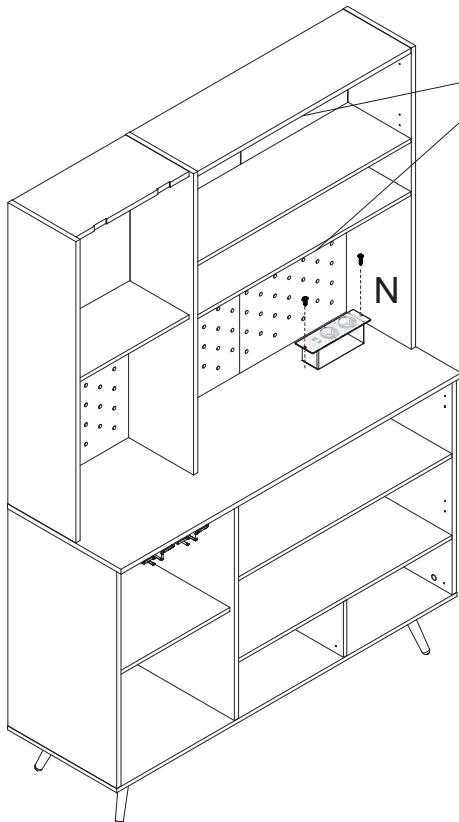

EN:Tear off the back tape
 DE:Das Klebeband auf der Rückseite abziehen
 FR:Retirez le ruban adhésif arrière
 ES:Quitar la cinta trasera
 IT:Strappare il nastro posteriore

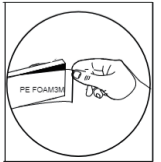

EN:Scan to download App control the Led light.
 DE:Das led-display wird durchsucht.
 FR:Scanner pour télécharger App contrôler la lumière Led.
 IT:Scansiona per scaricare l' applicazione controlla la luce Led.
 ES:Analice para descargar la aplicación control de la luz Led.

25



Dx26PCS

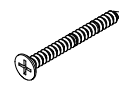

Ex6PCS

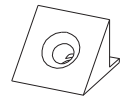

Ox26PCS

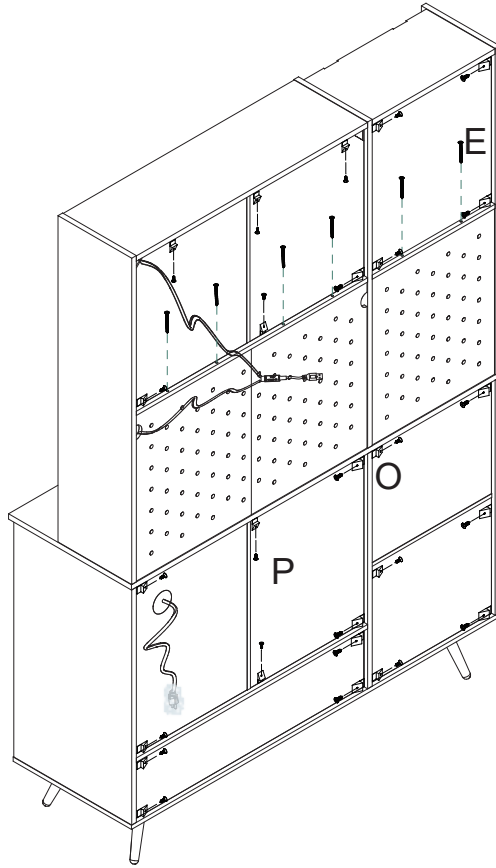

26



Dx20PCS



Kx4PCS

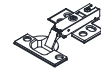

Lx6PCS



Mx4PCS

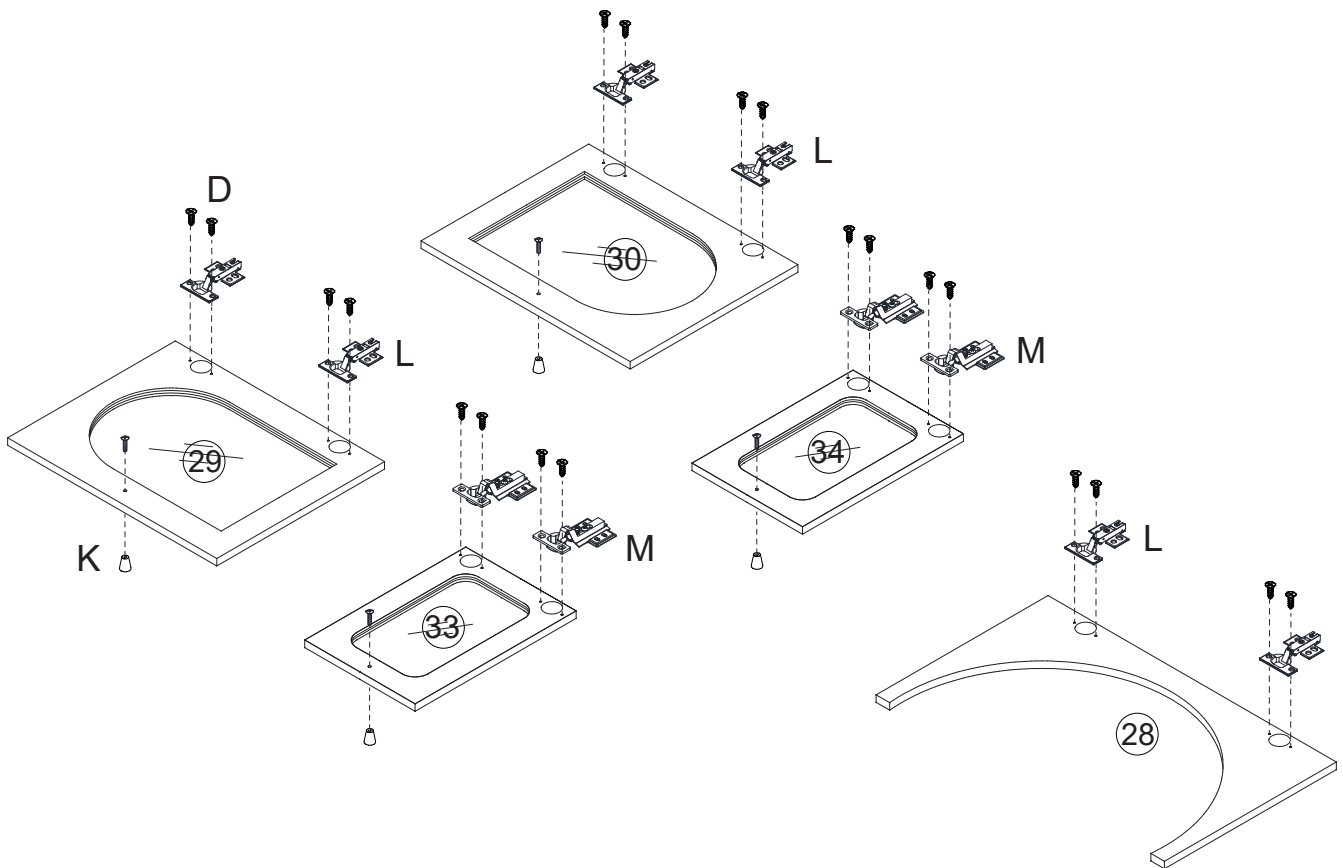

27

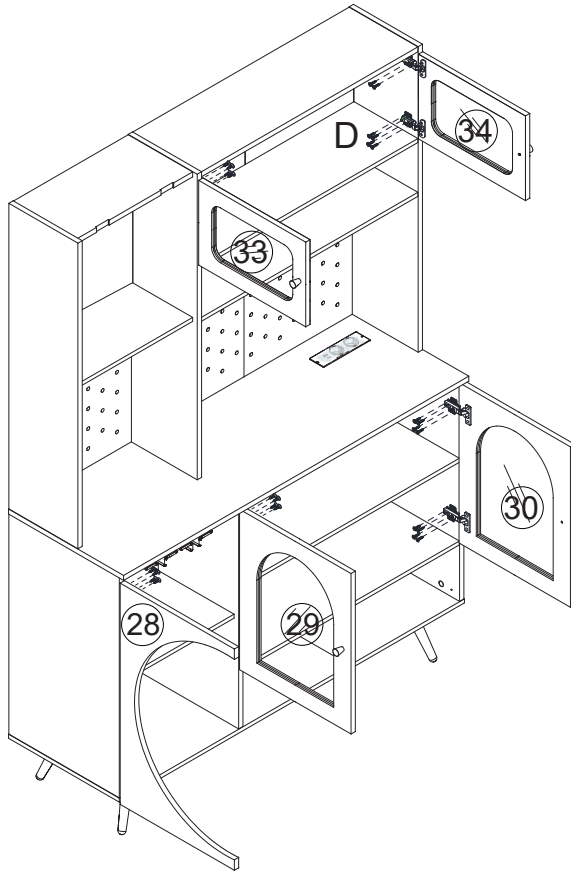

28

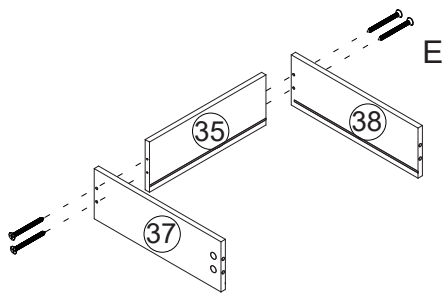
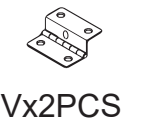
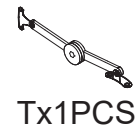
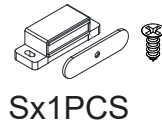

x2

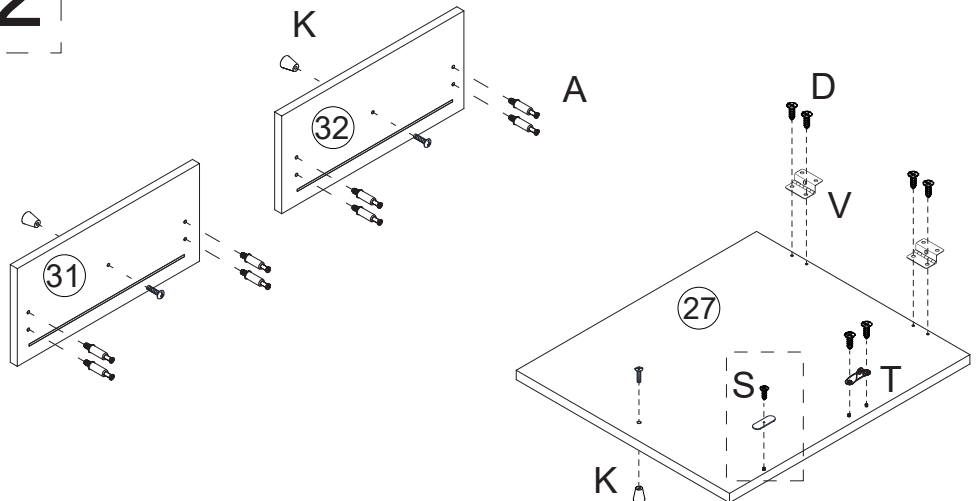

29

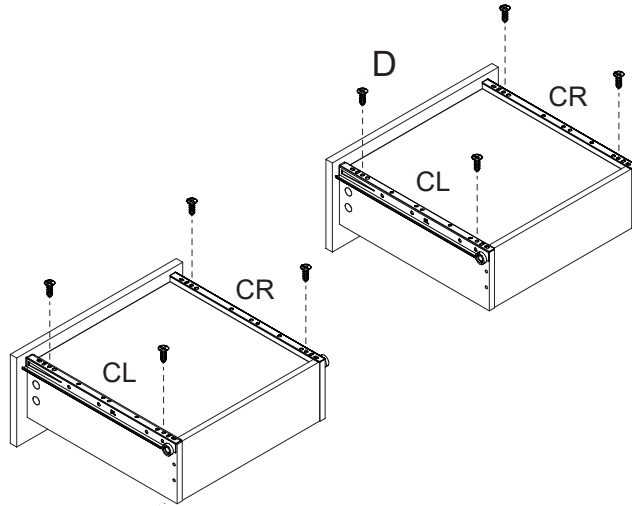
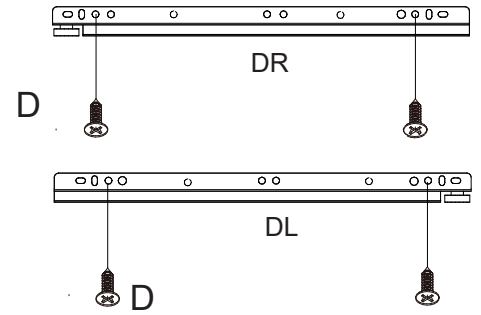
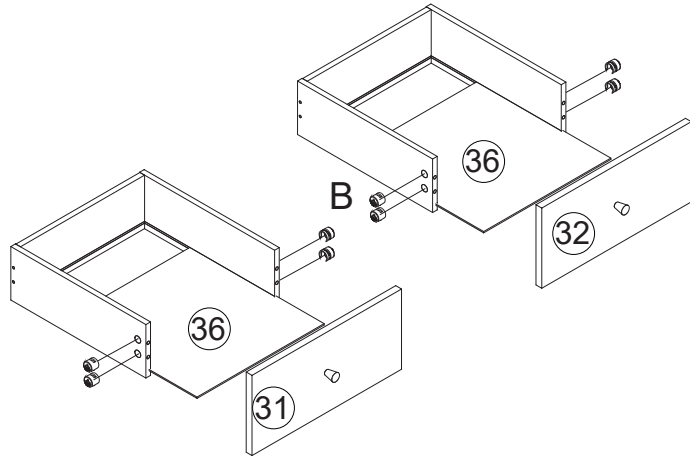

30

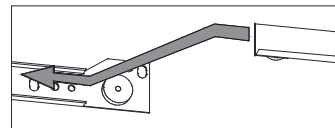
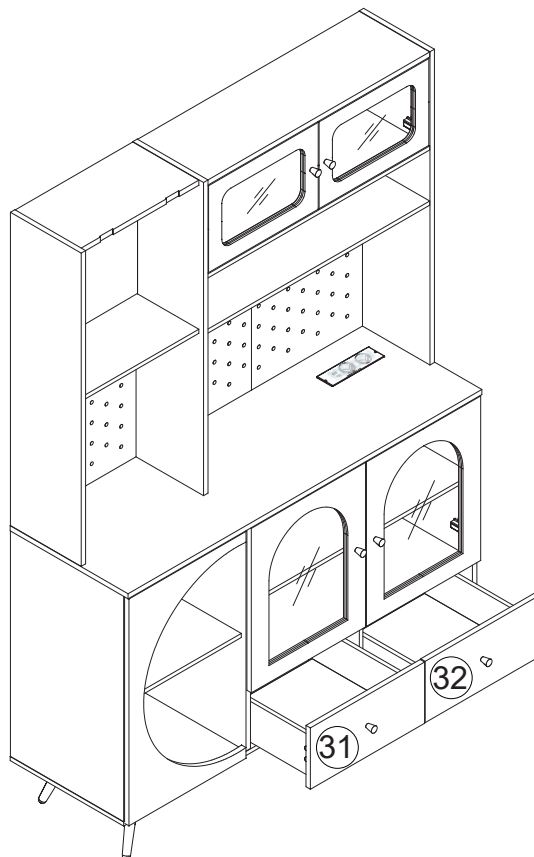





31

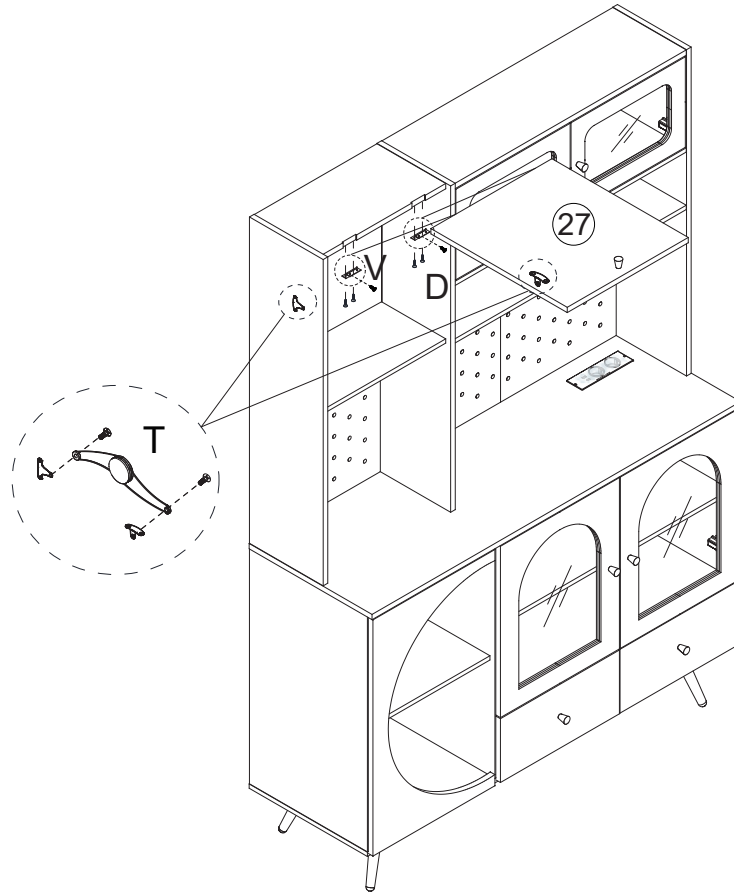

Dx6PCS

Tx1PCS

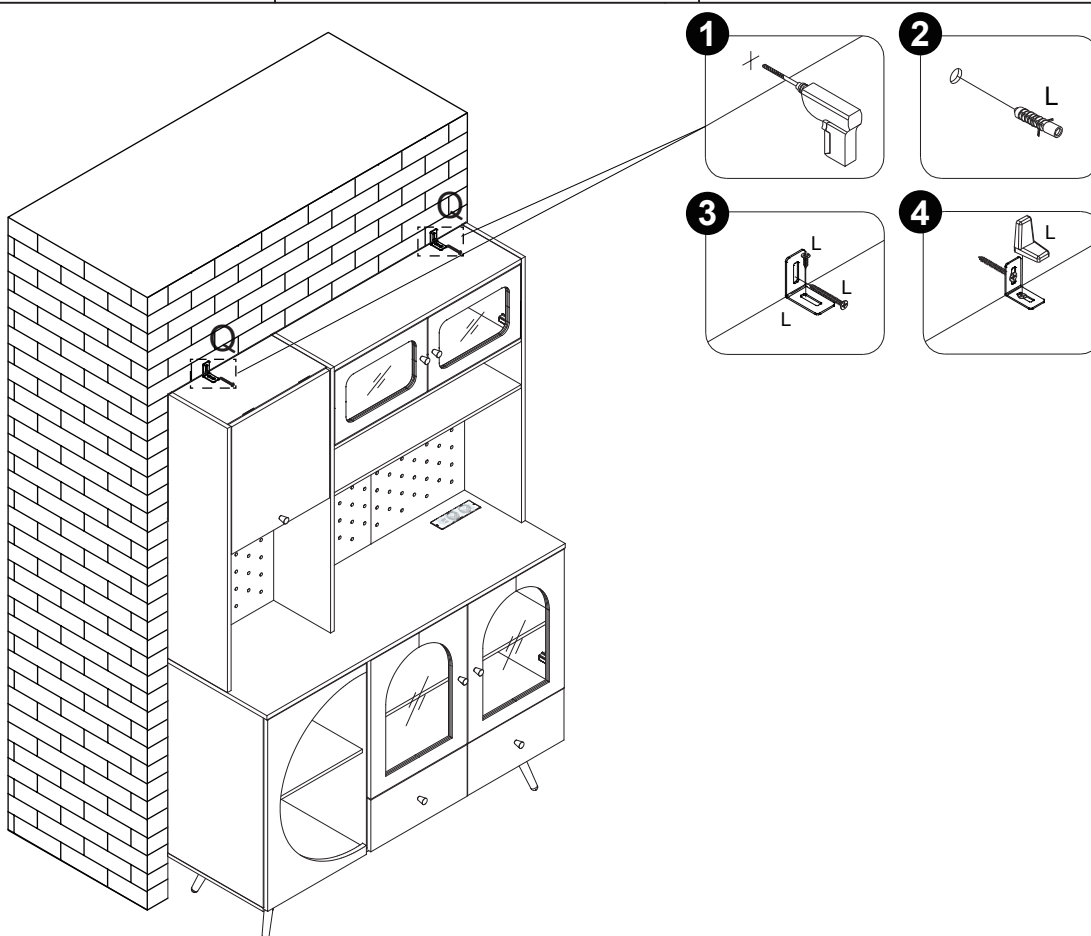

32

  6x30  4x30 
Px2PCS



Q



[DE]

BITTE BEACHTEN: Teilenummer **20.21.22.25** ist mit einer dichten Kunststoffschutzfolie überzogen. Wenn das Produkt nach der Demontage Kratzer aufweist, machen Sie sich bitte keine Sorgen, es handelt sich nicht um einen Produktschaden. Bitte ziehen Sie die schützende Kunststofffolie langsam entlang der Kante von der Oberfläche ab. Nach dem Abziehen wird das Produkt glatt und sauber.

[EN]

PLEASE NOTE: Part number **20.21.22.25** are covered with a tight plastic protective film. If there are scratches on the product after disassembly, please don't worry, it's not product damage. Please slowly tear off the protective plastic film on the surface along the edge. After peeling off, the product becomes smooth and clean.

[FR]

REMARQUE : les pièces numéro **20.21.22.25** sont recouvertes d'un film protecteur en plastique étanche. Si le produit présente des rayures après le démontage, ne vous inquiétez pas, il ne s'agit pas d'un dommage au produit. Retirez lentement le film protecteur en plastique sur la surface le long du bord. Une fois décollé, le produit devient lisse et propre.

[IT]

NOTA BENE: il numero di parte **20.21.22.25** è coperto da una pellicola protettiva in plastica stretta. Se ci sono graffi sul prodotto dopo lo smontaggio, non preoccuparti, non è un danno al prodotto. Strappare lentamente la pellicola protettiva in plastica sulla superficie lungo il bordo. Dopo averla staccata, il prodotto diventa liscio e pulito.

[ES]

NOTA: La pieza número **20.21.22.25** está cubierta con una película protectora de plástico. Si hay rayones en el producto después de desmontarlo, no se preocupe, no se trata de daños en el producto. Retire lentamente la película protectora de plástico de la superficie a lo largo del borde. Después de despegarla, el producto quedará liso y limpio.

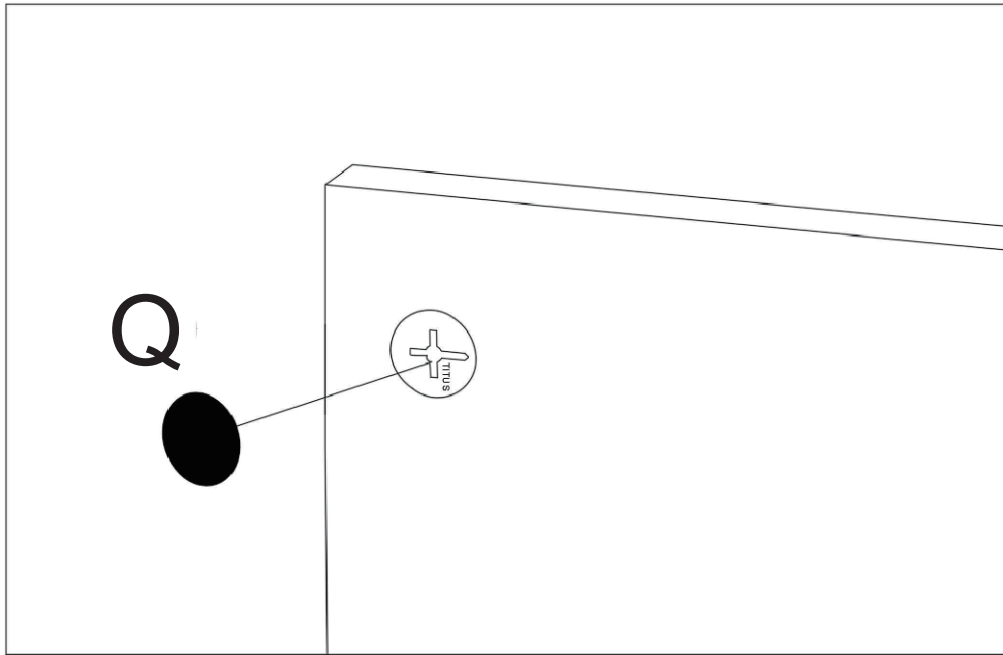

UK: After installing the product, stick the number J on the perforated position

FR: Une fois le produit installé, collez le numéro J à l'endroit où il ya des trous

DE: Nach der Installation des Produkts kleben Sie die Nummer J auf die perforierte Position

IT: Dopo l'installazione del prodotto, fissare il numero J sulla posizione perforata

ES: Después de instalar el producto, pegue el número J en la posición perforada

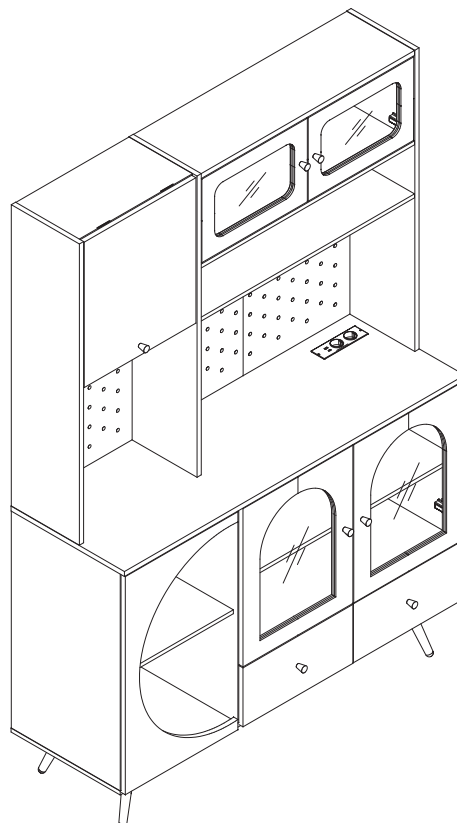

Q	x74



Reference No. : WTN24N06132846E
 Applicant : Guangdong Zhongong Electric Technology Co., Ltd.
 Address : 701, Building 29, Zhifu Garden, Xingtan Town, Shunde District, Foshan City
 Manufacturer : Same as applicant
 Address : Same as applicant
 Product : Furniture socket
 Model No. : ZG-PDU J00/10A/16A, others see attachment
 Technical data : 250 Vac, 50 Hz, other details see attachment

Test Standards:

- EN 55032:2015+A11:2020
- EN 55035:2017+A11:2020
- EN IEC 61000-3-2:2019+A1:2021
- EN 61000-3-3:2013+A1:2019+A2:2021

The above product has been tested by us with the listed standards and found in compliance with the European Electromagnetic Compatibility Directive 2014/30/EU. It is possible to use CE marking to demonstrate the compliance with this EMC Directive.

- EN 55032: Electromagnetic compatibility of multimedia equipment - Emission Requirements
- EN 55035: Electromagnetic compatibility of multimedia equipment - Immunity requirements
- EN IEC 61000-3-2: Electromagnetic compatibility (EMC) - Part 3-2: Limits - Limits for harmonic current emissions (equipment input current ≤ 16 A per phase)
- EN 61000-3-3: Electromagnetic compatibility (EMC) -Part 3-3: Limits -Limitation of voltage changes, voltage fluctuations and flicker in public low-voltage supply systems, for equipment with rated current ≤ 16 A per phase and not subject to conditional connection



The referred test report(s) show that the product complies with standard(s) recognized as giving presumption of compliance with the essential requirements in the above mentioned EU Directive. Other relevant Directives have to be observed.

After preparation of the necessary technical documentation as well as the EU Declaration of Conformity, the CE marking as shown below can be affixed on the equipment under the sole responsibility of the manufacturer.



Manager: Jianzhong Mao
 Date: 2024-07-15

The statement is based on a single evaluation of the sample of above mentioned product. It does not imply an assessment of the whole production.

Waltek Testing Group (Ningbo) Co., Ltd.

Hotline: 400-840-2288 E-mail: nb@waltek.com.cn
 Http://www.waltek.com.cn

Ver.10.22, WALTEK is registered trademark. Utilisation and application requires prior approval.

Importeur	Decobus Handel GmbH
Adresse	Innungsstraße 9, 21244 Buchholz, Deutschland
URL	https://www.decobusgroup.de
Hersteller	Guangdong Zhongong Electric Technology Co., Ltd.
Adresse	701, Building 29, Zhifu Industrial Zone, Xingtan Town, Shunde District, Foshan city, GuangdongZ
Email/URL	rita@zhangongsocket.com
Partienummer	N620P386804/N620P386805/N620P386806
Hergestellt in	CHINA
EC REP	Decobus Handel GmbH Innungsstraße 9, 21244 Buchholz, Deutschland https://www.decobusgroup.de



Reference No. : WTN23D07163421R1Z
 Applicant : Guangdong Zhangong Electrical Technology Co., LTD
 Address : 701, Building 29, Zhifu Garden, Xingtan Town, Shunde District, Foshan City
 Manufacturer : Guangdong Zhangong Electrical Technology Co., LTD
 Address : 701, Building 29, Zhifu Garden, Xingtan Town, Shunde District, Foshan City
 Product : Furniture socket
 Model No. : See model list
 Technical data : 250V AC, 50-60Hz 13A USB, output:5.0V 2A 10W



Test Standards:

BS 1363-2: 2016+A1:2018

BS EN IEC 62368-1:2020/A11:2020

The above product has been tested by us with the listed standards and found in compliance with the Electrical Equipment (Safety) Regulations 2016 of United Kingdom (S.I. 2016 No.1101). It is possible to use UKCA marking to demonstrate the compliance with the regulations.

Audio/video, information and communication technology equipment- Part 1:Safety requirements

13 A plugs, socket outlets, adaptors and connection units-Part 2: Specification for 13 A switched and unswitched socket outlets

The referred test report(s) show that the product complies with standard(s) recognized as giving presumption of compliance with the essential requirements in the above mentioned UK regulations. Other relevant UK regulations have to be observed.

After preparation of the necessary technical documentation as well as the declaration of conformity, the UKCA marking as shown below can be affixed on the equipment under the sole responsibility of the manufacturer.



Deval qin
 Manager:Deval Qin
 Date: 2024-07-08

The statement is based on a single evaluation of the sample of above mentioned product. It does not imply an assessment of the whole production.

Waltek Testing Group Co., Ltd.

Hotline:400-840-2288

E-mail:info@waltek.com.cn

Http://www.waltek.com.cn

Ver.02. 29.07.2022, WALTEK is registered trademark. Utilisation and application requires prior approval.

Importeur	COMHARBOR LIMITED
Adresse	Unit C, Swift Point, Cosford Lane, Rugby, CV21 1PY,GB
URL	harborcomhar@gmail.com
Hersteller	Guangdong Zhangong Electric Technology Co., Ltd.
Adresse	701, Building 29, Zhifu Industrial Zone, Xingtan Town, Shunde District, Foshan city, Guangdong
Email/URL	rita@zhangongsocket.com
Partienummer	N639P386889/N639P386890/N639P386891
Hergestellt in	CHINA
	COMHARBOR LIMITED Unit C, Swift Point, Cosford Lane, Rugby, CV21 1PY,GB harborcomhar@gmail.com



Shenzhen ZKT Technology Co., Ltd.
 1/F, No. 101, Building B, No. 6, Tangwei Community Industrial Avenue,
 Fuhai Street, Bao'an District, Shenzhen, China



Certificate of Compliance

Certificate Number: ZKT-250109L0779C

Certificate's Holder : Shenzhen xu xing technology co., LTD
 Floor 3, building C, Huaze hi tech Industrial Park, Shiyan street,
 Bao'an District, Shenzhen

Manufacturer : Shenzhen xu xing technology co., LTD
 Floor 3, building C, Huaze hi tech Industrial Park, Shiyan street,
 Bao'an District, Shenzhen

Trade Mark : /

Product : Colorful light strip

Model(s) : XX5050RGB-60D
 XX5050RGB-30D, XX5050RGB-72D, XX5050RGB-96D,
 XX5050RGB-120D, XX2835-120D, XX2835-60D, XX2835-150D,
 XX2835-240D, XX2835-W, Y-120D, XX2835-W, Y-60D, XX2025-120D

Test Standard : BS EN IEC 55015:2019+A11:2020
 BS EN IEC 61547:2023
 BS EN IEC 61000-3-2:2019+A2:2024
 BS EN 61000-3-3:2013+A2:2021

This certificate of compliance is issued according to the UK legislation: Electromagnetic Compatibility Regulations 2016(S.I. 2016/1091), Referred to as the UK Electromagnetic Compatibility.

It confirms that the listed product complies with all essential requirements of the Electromagnetic Compatibility Regulations 2016 and applies only to the sample and its technical documentation submitted to Guangdong Shenzhen ZKT Technology Co., Ltd.(ZKT) for testing.

It is only valid in connection with the test report number: ZKT-250109L0779E.

So ZKT here by acknowledges that the Manufacturer may issue a COC apply the UKCA marketing in according with United Kingdom Union Rules.

After preparation of the necessary technical documentation (Which must be kept for up to 10 years after the product is placed on the GB market as well as the UK declaration of conformity, the required UKCA marking can be affixed on the product. Other relevant Regulations have to be observed.



This Certificate of Conformity is based on single evaluation of the submitted sample(s) of the above mentioned product. It does not imply an assessment of the whole product and relevant Directives to be observed.

☎ +86-400 000 9970 📠 +86-755-22336688 ✉ zkt@zkt-lab.com 🌐 www.zkt-lab.com

Importeur	COMHARBOR LIMITED
Adresse	Unit C, Swift Point, Cosford Lane, Rugby, CV21 1PY,GB
URL	harborcomhar@gmail.com
Hersteller	Shenzhen xu xing technology co., LTD
Adresse	Floor 3, building C, Huaze hi tech Industrial Park, Shiyan street, Bao'an District, Shenzhen
Email/URL	18665363779@163.com
Partienummer	N639P386889/N639P386890/N639P386891
Hergestellt in	CHINA
UK REP	COMHARBOR LIMITED Unit C, Swift Point, Cosford Lane, Rugby, CV21 1PY,GB harborcomhar@gmail.com



Produkt: LED-Lichtstreifen
 Modell: CSX-5050
 Nennspannung: 5V
 Leistung: 15W/M

Shenzhen Promise Test Technology Co.,Ltd.
 103, Building 1, Yibaolai Industrial City, Qiaotou Community, Fuhai
 Street, Baoan District, Shenzhen, Guangdong, China.



Certificate of Compliance

Certificate No.: PRMS2412153SC

Applicant : Shenzhen xu xing technology co., LTD
Address : Floor 3, building C, Huaze hi tech Industrial Park, Shiyang street, Bao'an District, Shenzhen
Manufacturer : Shenzhen xu xing technology co., LTD
Address : Floor 3, building C, Huaze hi tech Industrial Park, Shiyang street, Bao'an District, Shenzhen
Product : Colorful light strip
Trade Mark : /
Model(s) : XX5050RGB-60D
 XX5050RGB-30D, XX5050RGB-72D, XX5050RGB-96D, XX5050RGB-120D,
 XX2835-120D, XX2835-60D, XX2835-150D, XX2835-240D, XX2835-W,
 Y-120D, XX2835-W, Y-60D, XX2025-120D
Test Standard : IEC 62321-5:2013 & IEC 62321-4:2013+A1:2017 &
 IEC 62321-7-2:2017 & IEC 62321-6:2015 & IEC 62321-8:2017 & IEC
 62321-3-1:2013 & IEC 62321-7-1:2015

This certificate of compliance is based on a test procedure or an evaluation of the above-mentioned product. This is to certify that the above-mentioned product is in compliance with the RoHS Directive 2011/65/EU Annex II amending Annex (EU)2015/863. It is only valid in connection with the test report number: PRMS2412153SR.

After preparation of the necessary technical documentation according the requirement of EN IEC 63000:2018 as well as the verification of conformity the CE marking as shown below can be affixed on the equipment.



Kind. Yang

Manager
 Dec. 05, 2024

This Certificate of Conformity is based on single evaluation of the submitted sample(s) of the above mentioned product. It does not imply an assessment of the whole product and relevant . Directives have to be observed.



+86-0755-23319501 info@pnms-test.com www.pnms-test.com

Importeur	Decobus Handel GmbH
Adresse	Innungsstraße 9,21244 Buchholz, Deutschland
URL	https://www.decobusgroup.de
Hersteller	Shenzhen xu xing tschnology co.,LTD
Adresse	Floor 3, building C, Huaze hi tech industrial Park, Shiyang street, Bao'an District, Shenzhen
Email/URL	18665363779@163.com
Partienummer	N620P386804/N620P386805/N620P386806
Hergestellt in	CHINA
EC REP	Decobus Handel GmbH Innungsstraße 9, 21244 Buchholz, Deutschland https://www.decobusgroup.de



Produkt: LED-Lichtstreifen
 Modell: CSX-5050
 Nennspannung: 5V
 Leistung: 15W/M