

Assembly Instructions

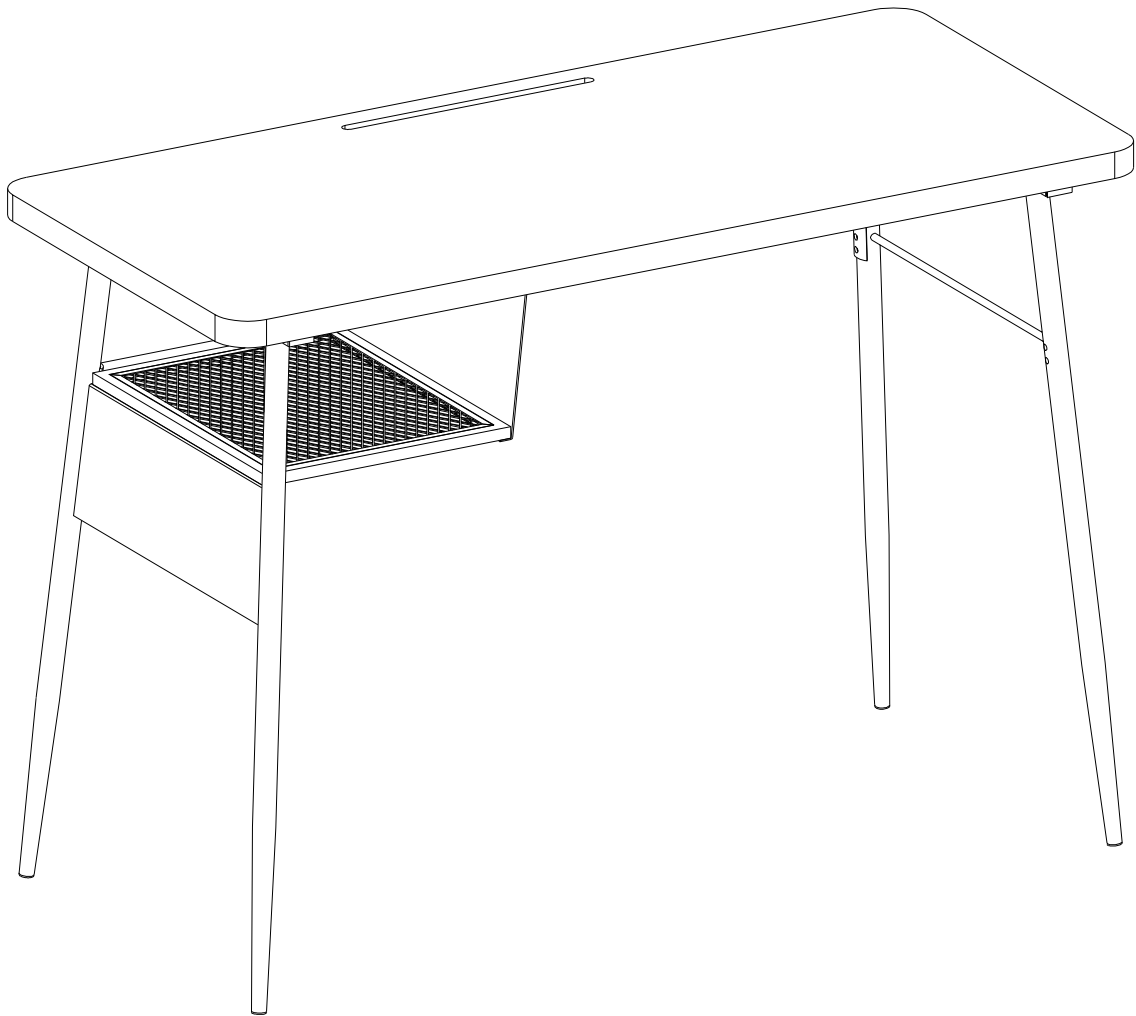

General Assembly Guidelines

- I. Ensure that all parts and hardware are available before beginning assembly.
- II. Follow each step carefully to ensure the proper assembly of this product.
- III. Two people are recommended for ease in the assembly of this product.
- IV. The main type of hardware used to assemble this product are: bolts and screws.
- V. Power tools should not be used to assemble this product.

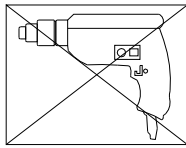

- VI. Drill may be needed for securing product to wall.

Parts List

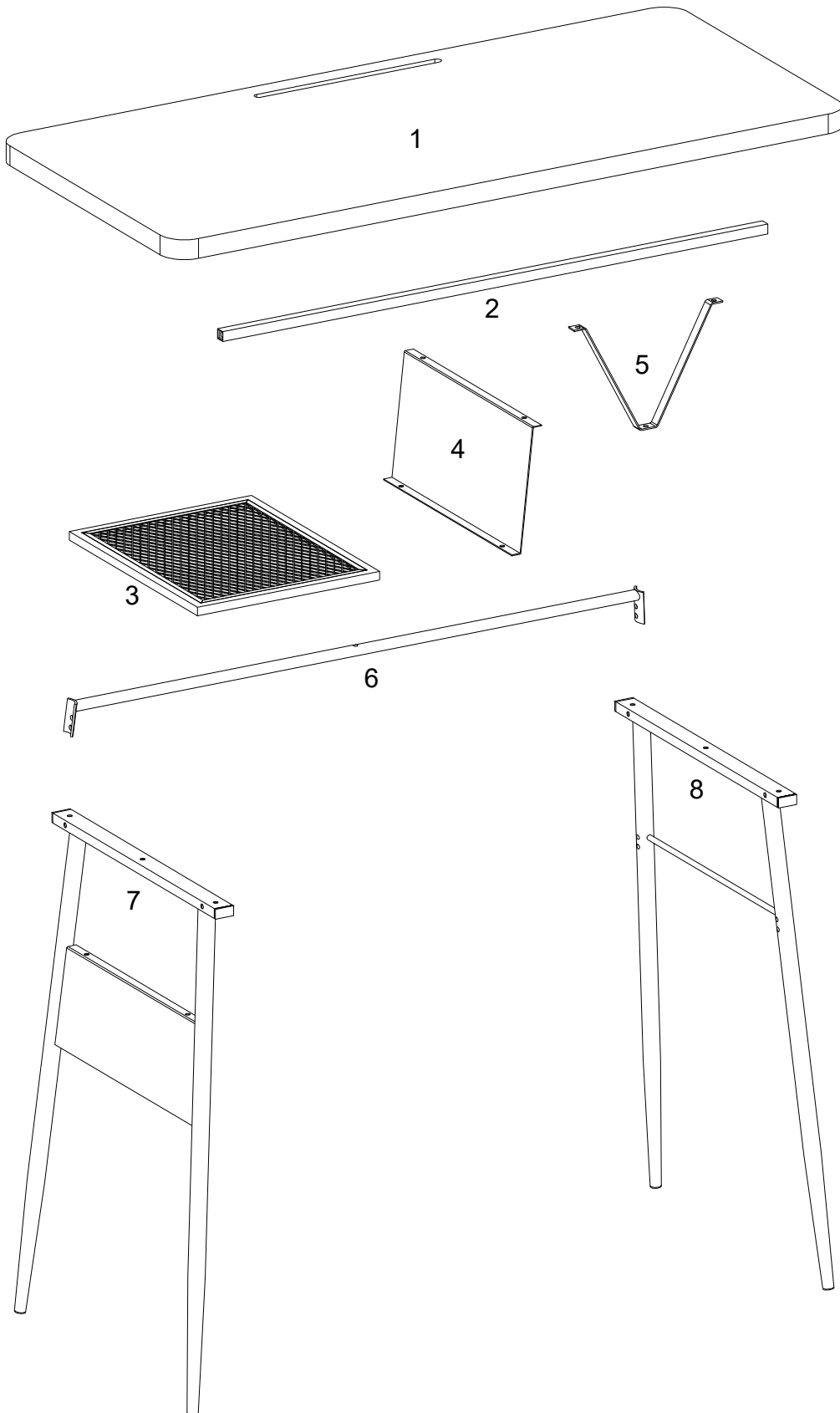

Hardware List

A		M6x15mm	Bolt	8 pcs
B		M6x27mm	Bolt	6 pcs
C		M6X45mm	Bolt	2 pcs
D		M 4	Hex key	1 pc
E		M6x12mm	Bolt	9 pcs

*The hardware quantities listed above are required for proper assembly.
Some extra hardware may also have been included.*

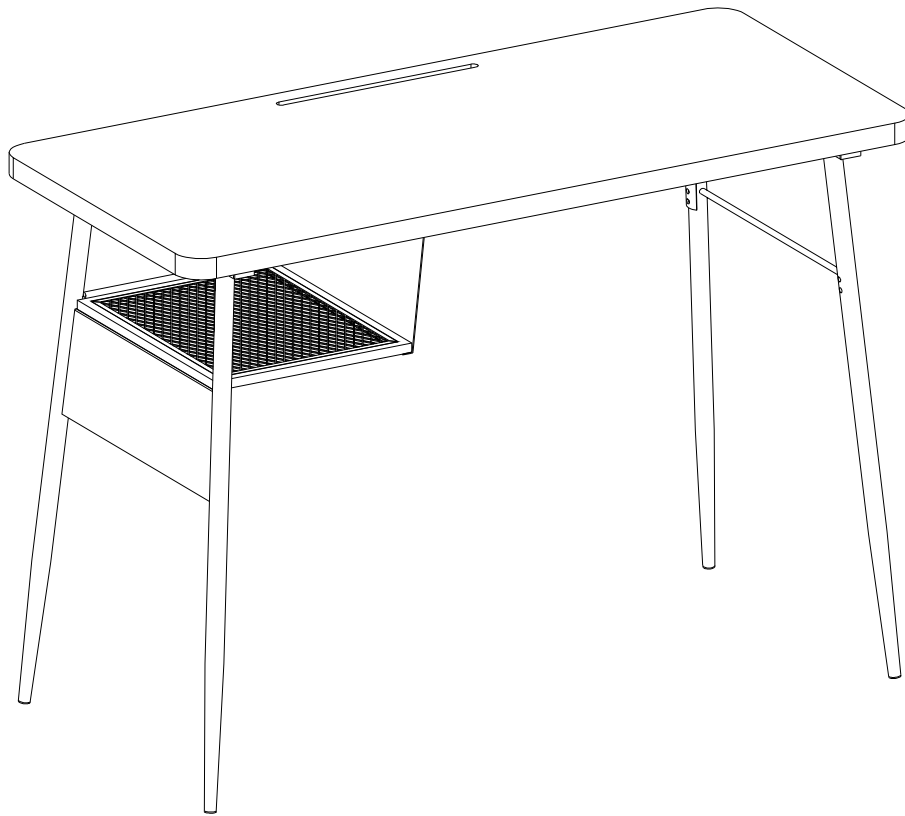

Version A

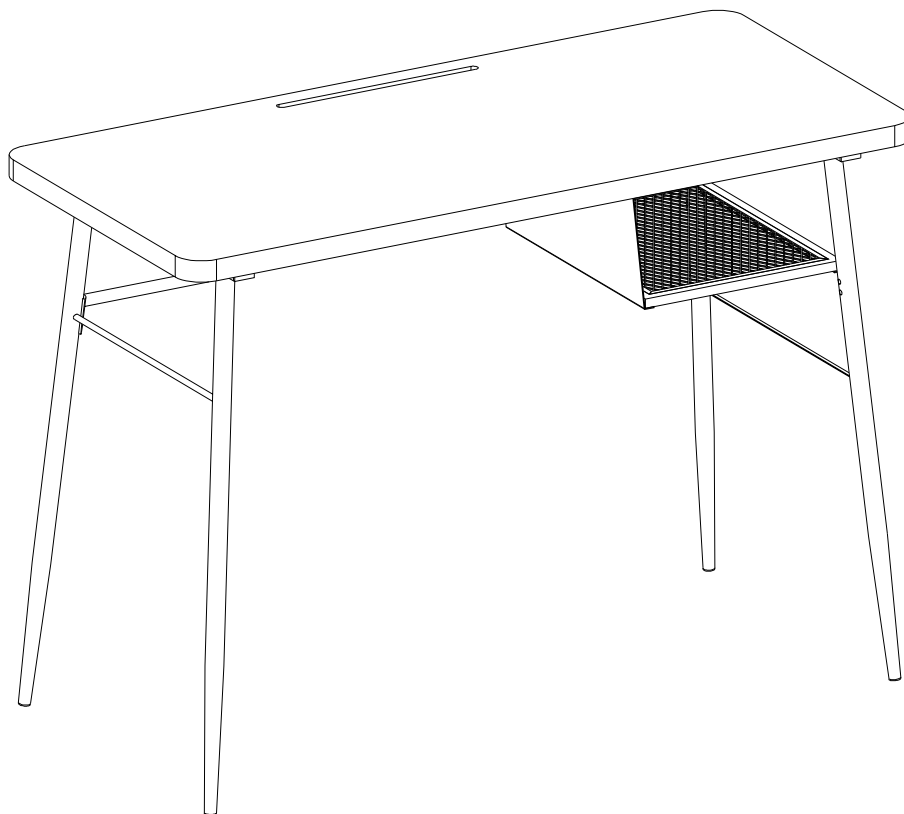

Version B

Step 1

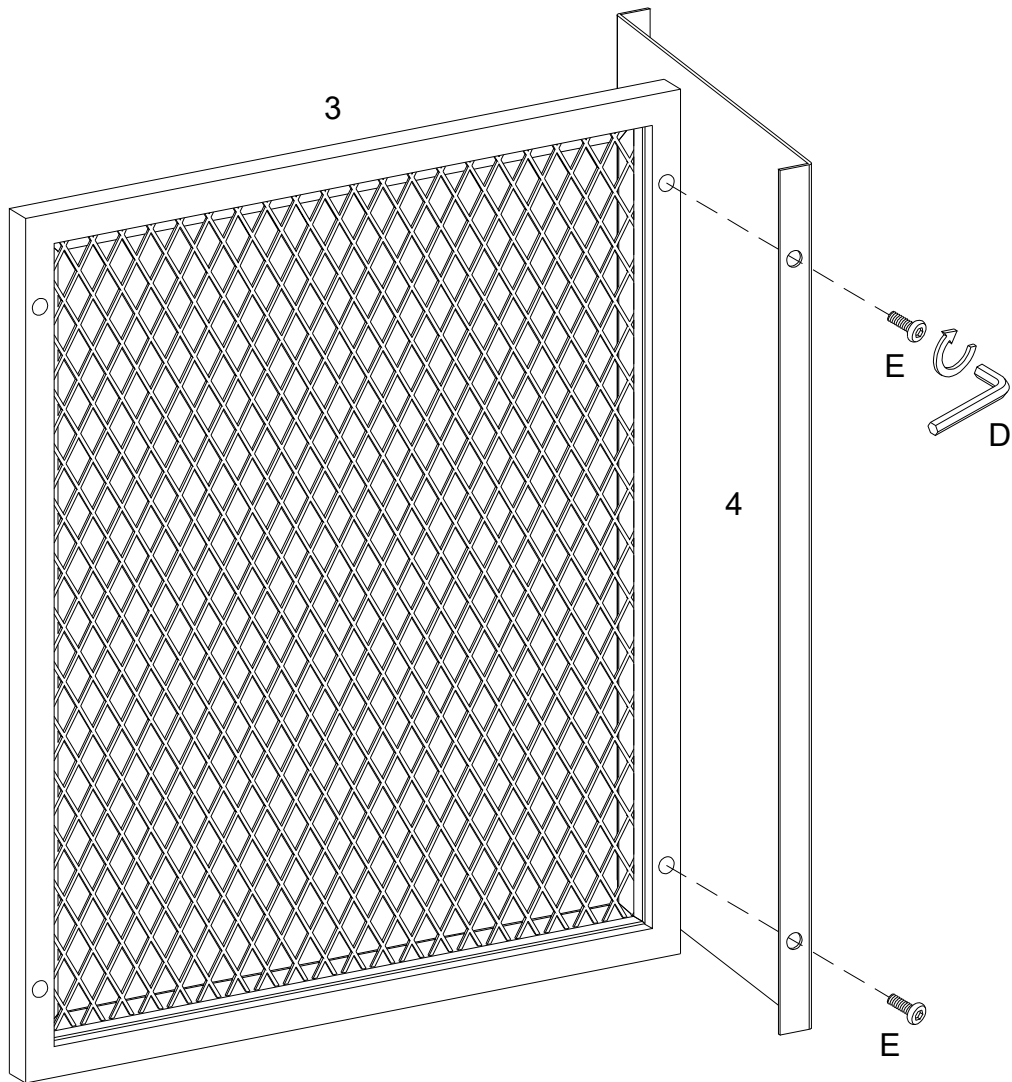

Using bolt (E) attach part (4) to part (3) with Hex Key (D) as per diagram.

Step 2

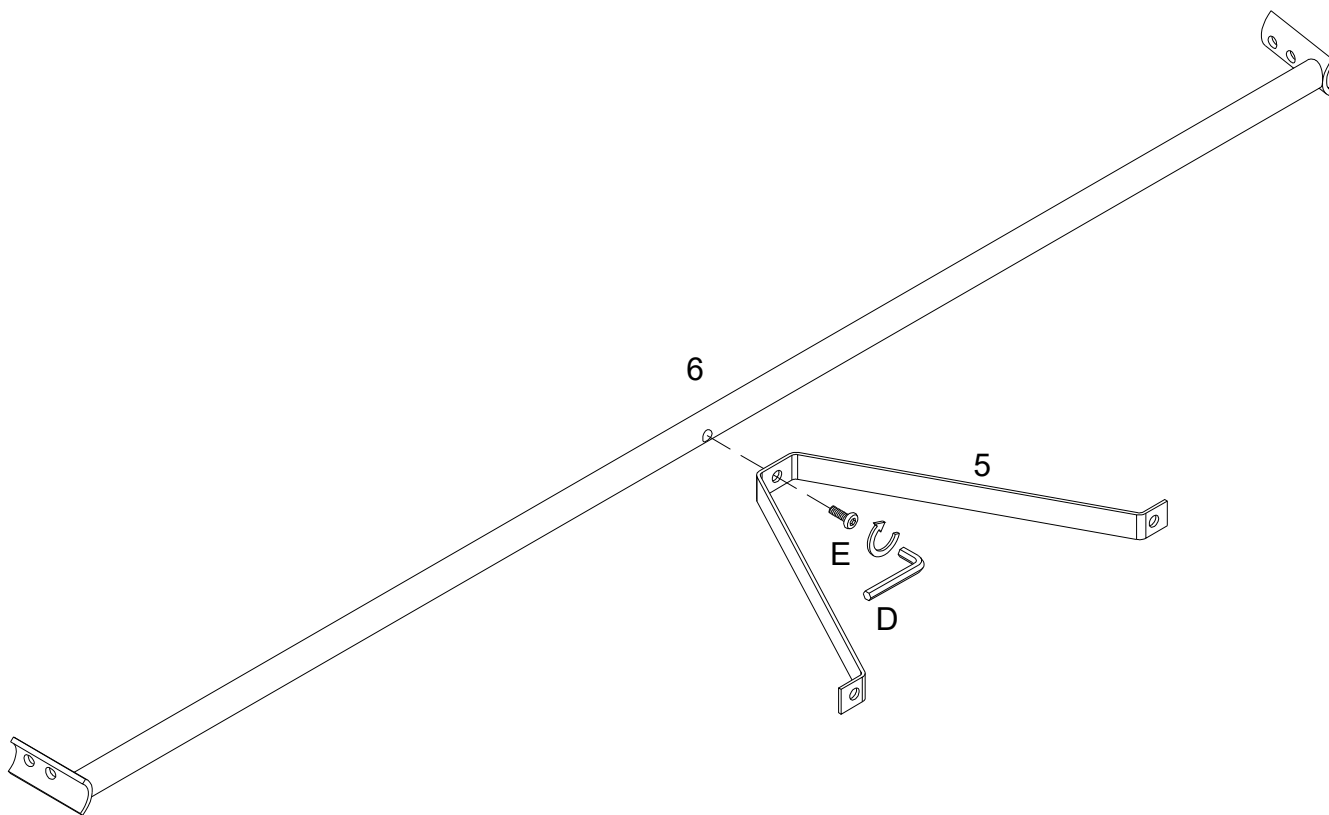

Using bolt (E) attach part (5) to part (6) with Hex Key (D) as per diagram.

Note: Do not fully tighten all bolts.

Step 3-A

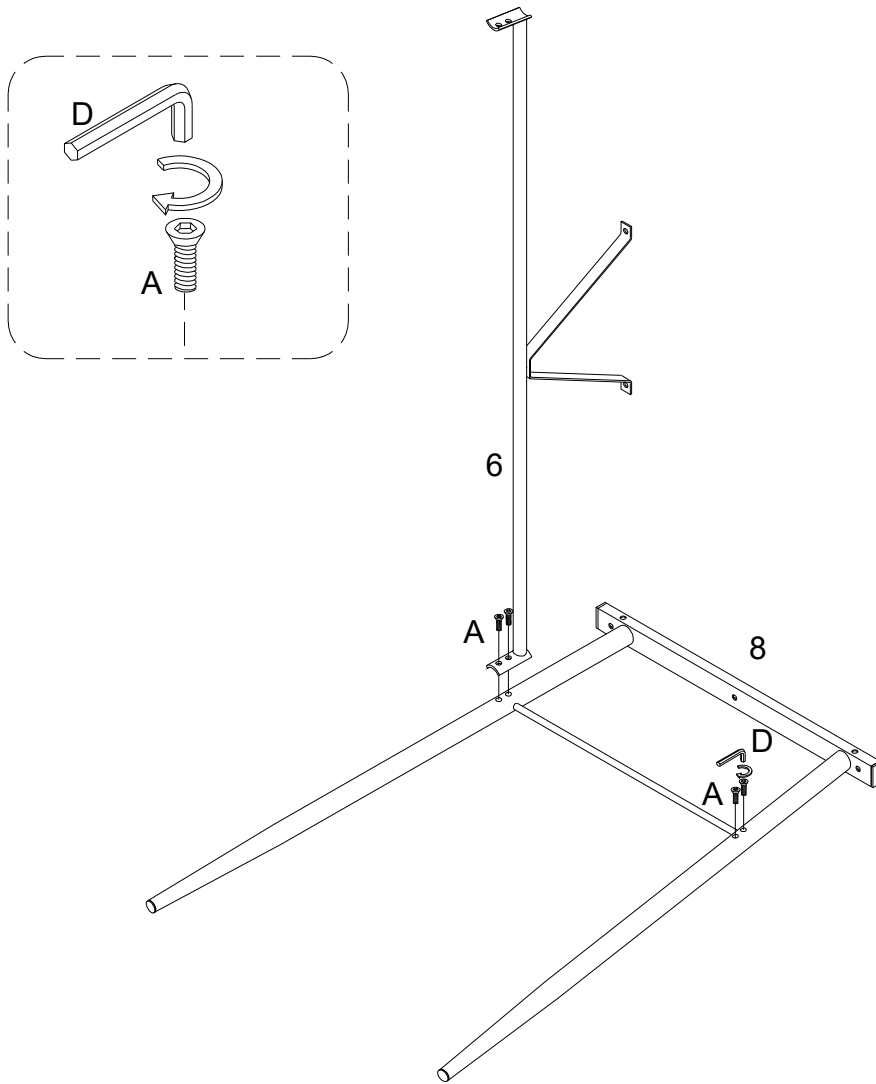

Using bolt (A) secure part (6) to part (8) with hex key (D) as per diagram.

Step 4-A

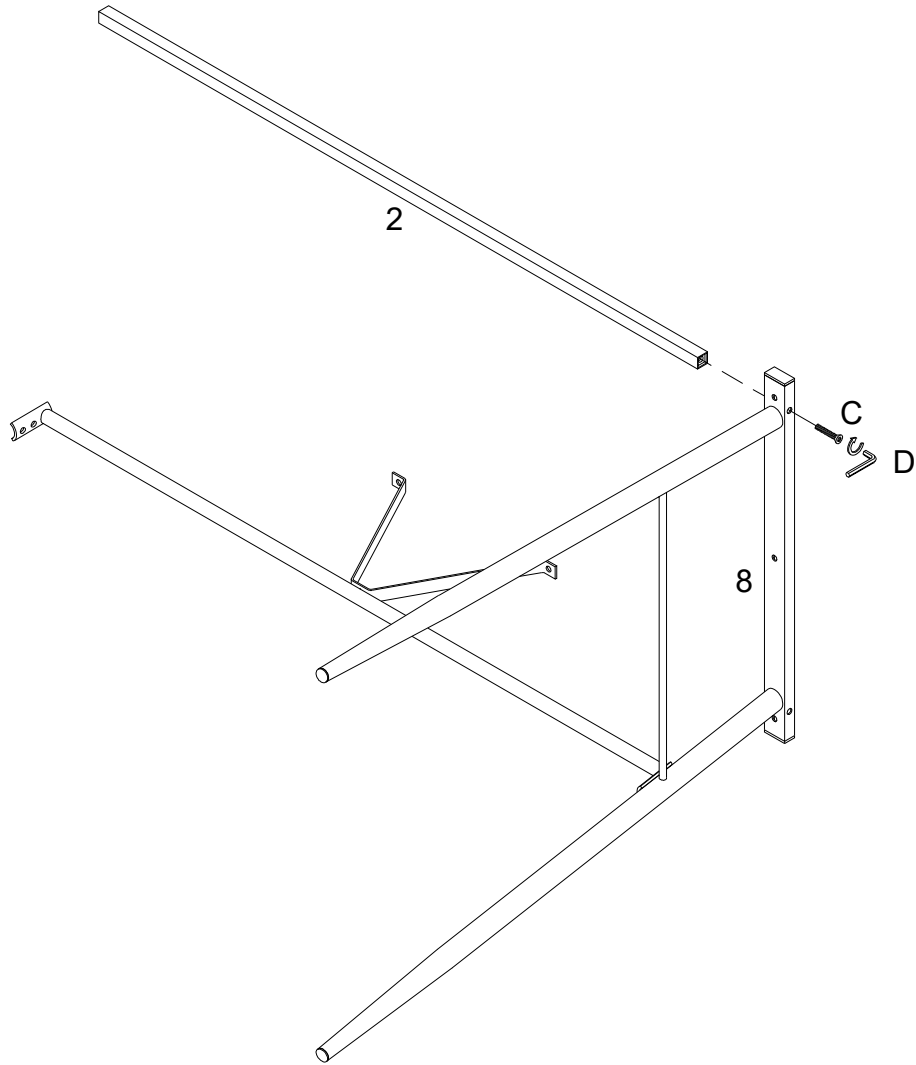

Using bolt (C) secure part (8) to part (2) with hex key (D) as per diagram.

Step 5-A

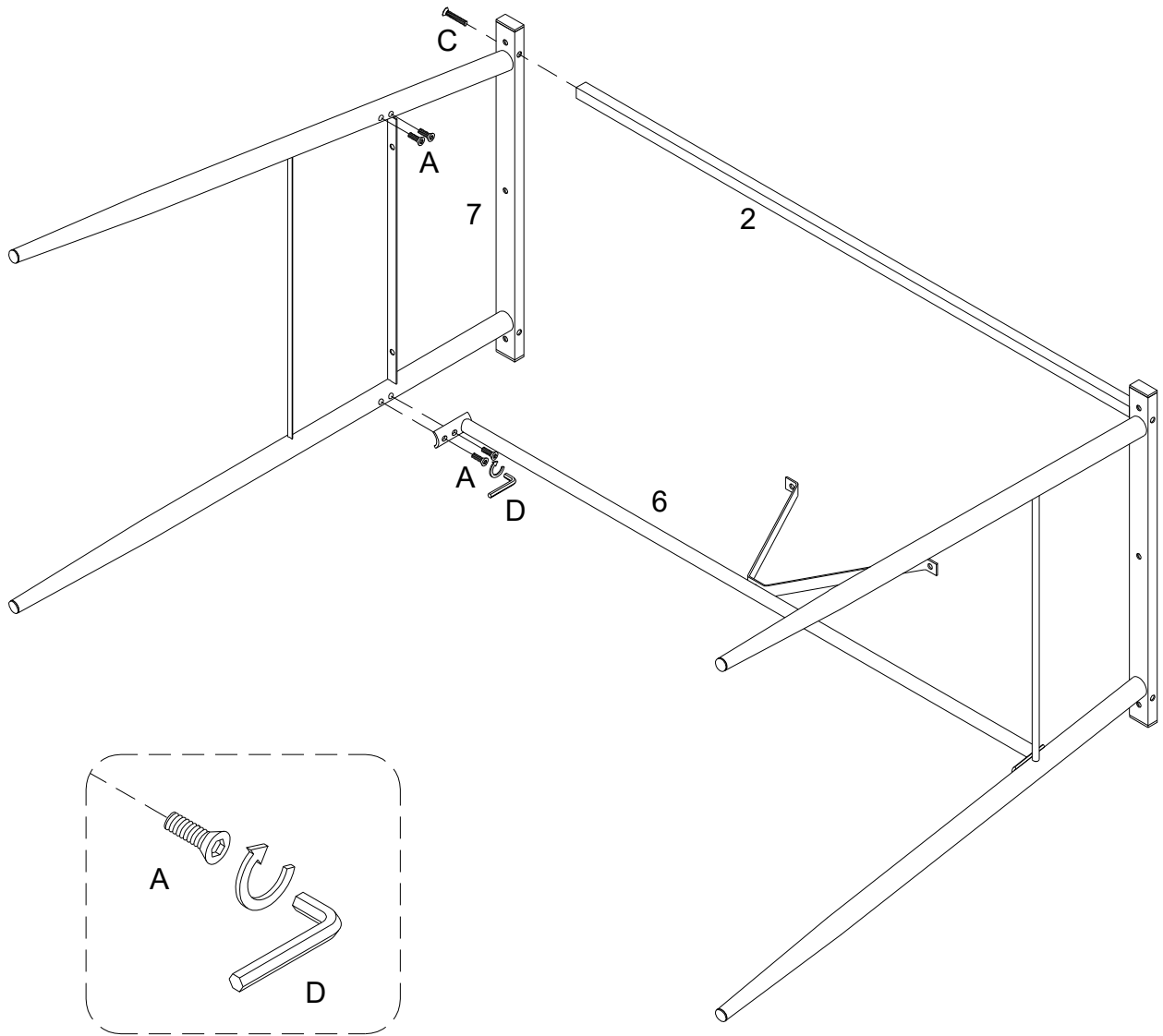

Using bolt (A) secure part (6) to part (7), and then using bolt (C) secure part (7) to part (2) with hex key (D) as per diagram.

Step 6-A

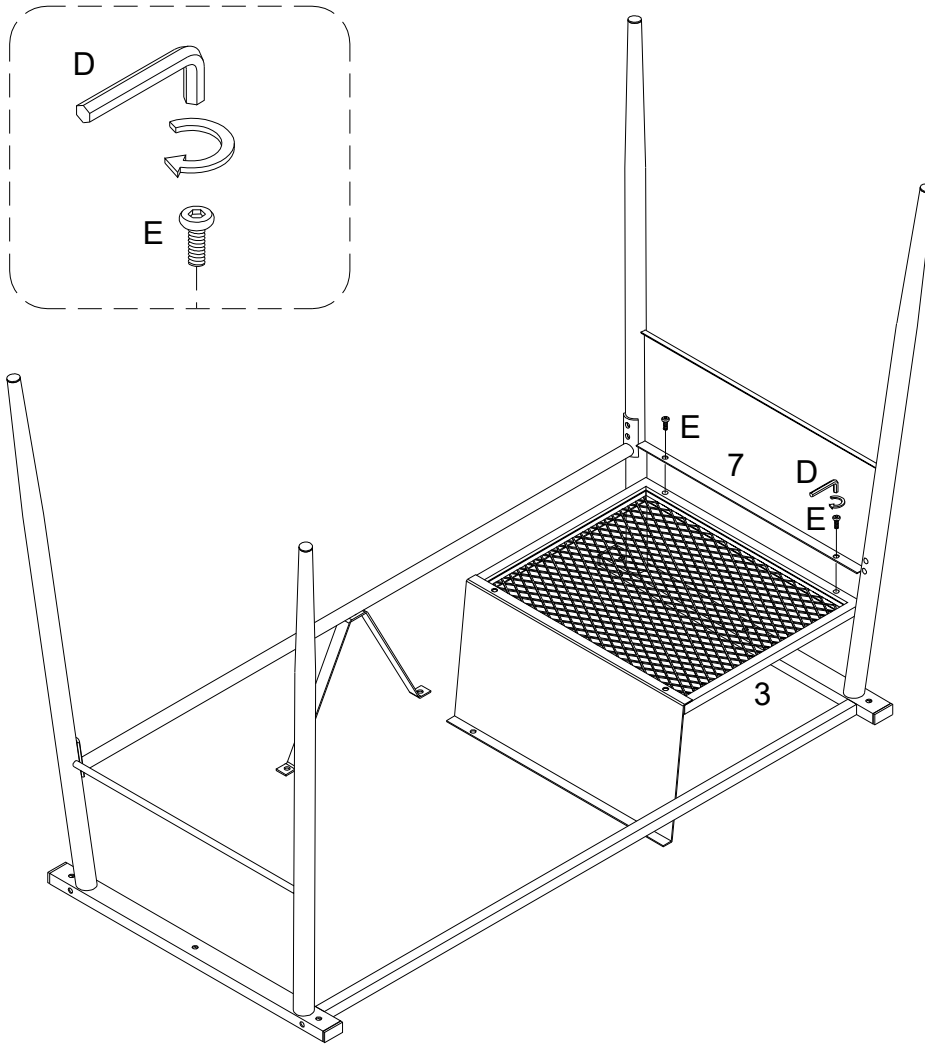

Using bolt (E) secure part (3) to part (7) with hex key (D) as per diagram.

Step 7-A

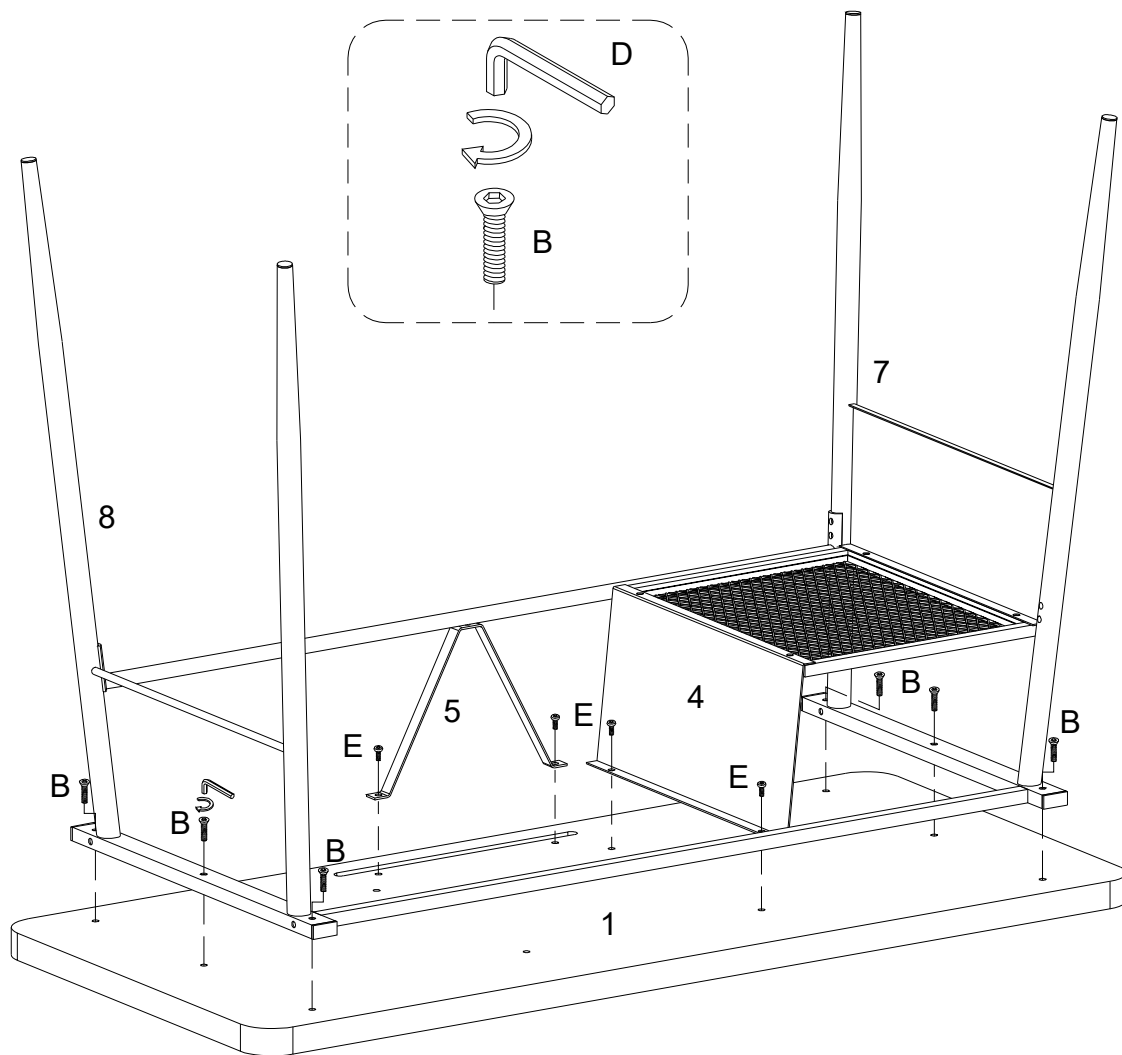

Using bolt (E) secure parts (4,5) to part (1), and using bolt (B) secure parts (7,8) to part (1) with hex key (D) as per diagram.

Note: Fully tighten all bolts.

Step 8

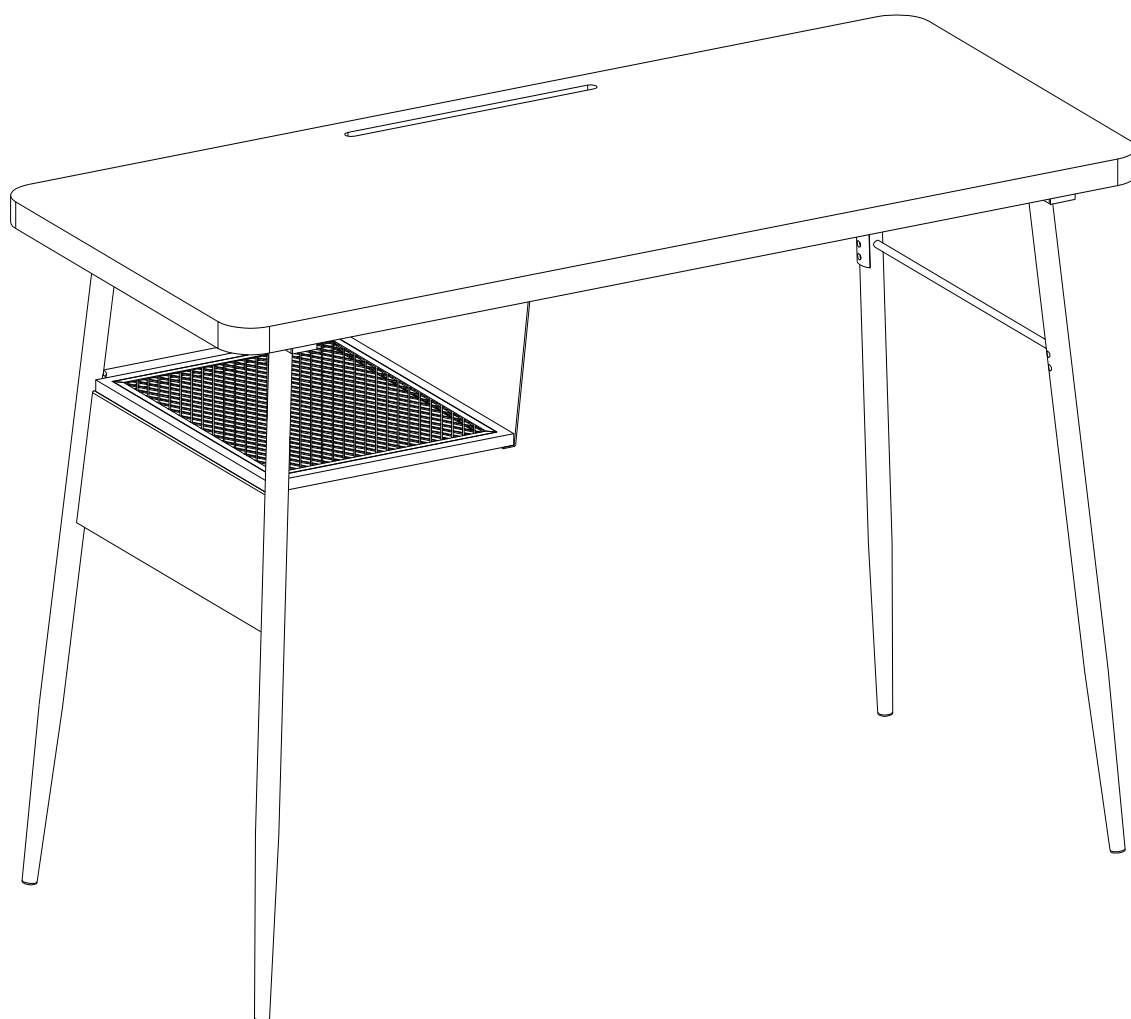

Version A
Final Assembly

Step 9-B

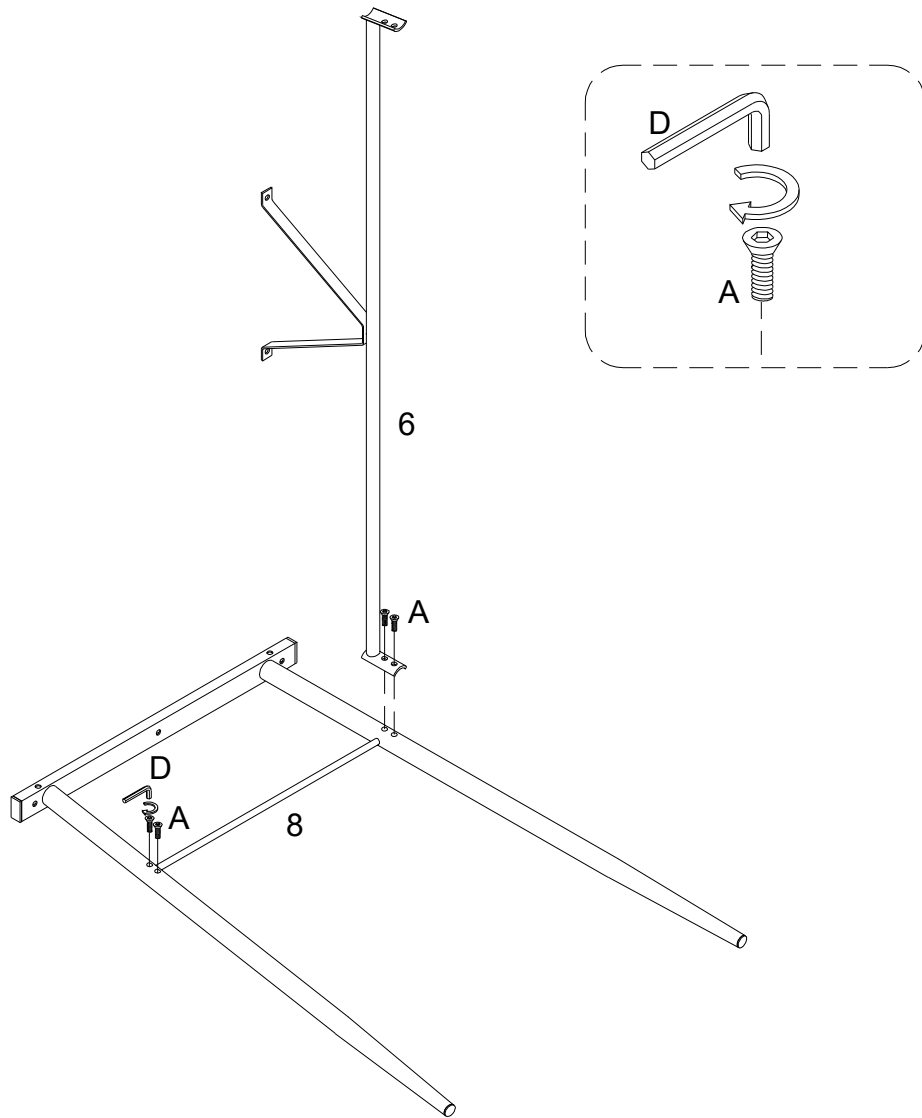

Using bolt (A) secure part (6) to part (8) with hex key (D) as per diagram.
Note: Do not fully tighten all bolts.

Step 10-B

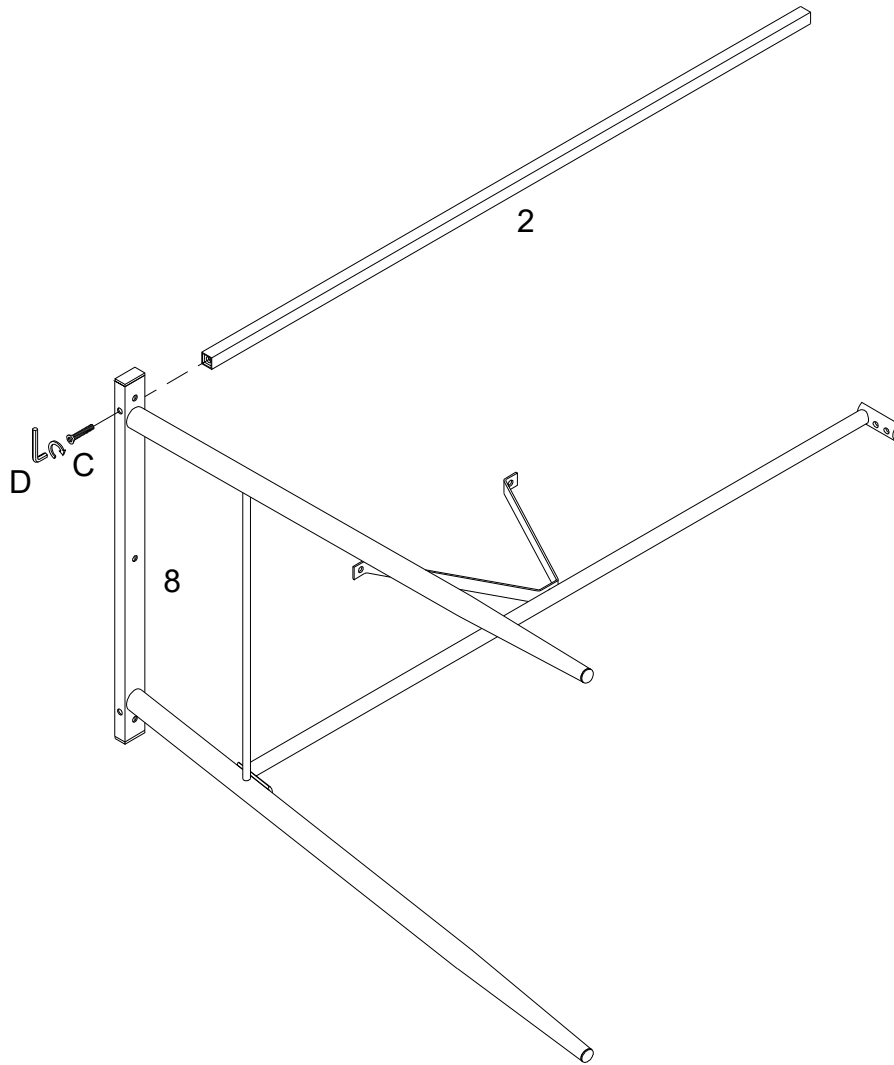

Using bolt (C) secure part (8) to part (2) with hex key (D) as per diagram.

Step 11-B

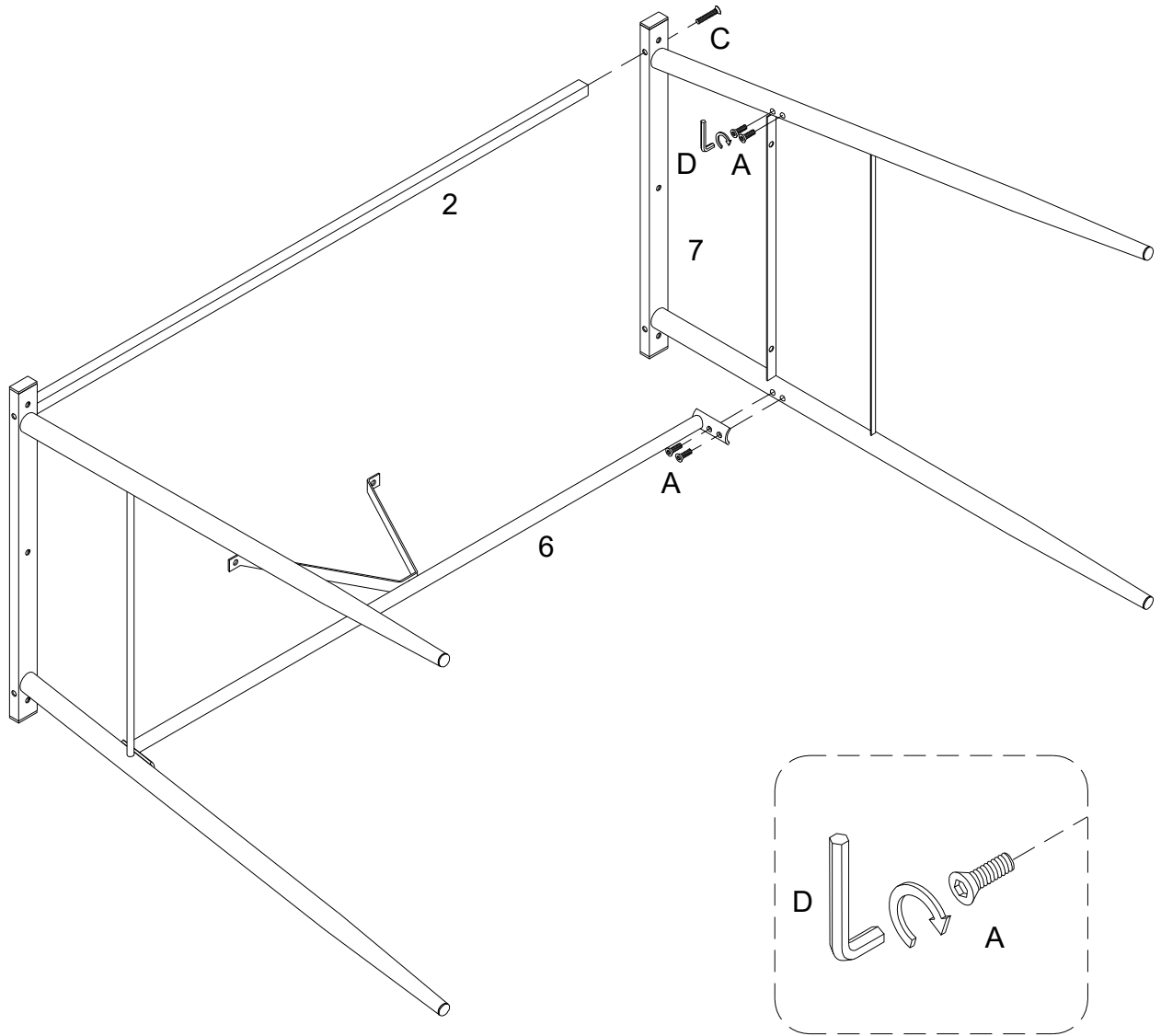

Using bolt (A) secure part (6) to part (7), and then using bolt (C) secure part (7) to part (2) with hex key (D) as per diagram.

Step 12-B

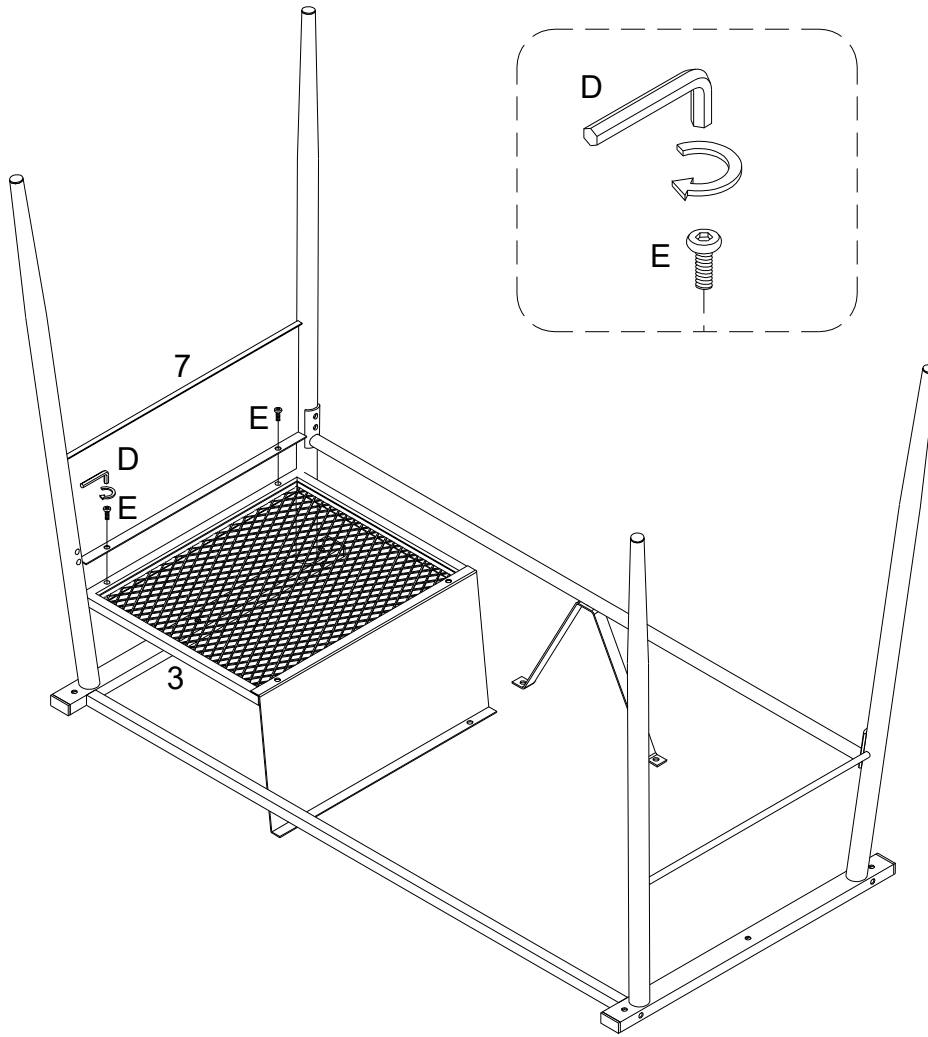

Using bolt (E) secure part (3) to part (7) with hex key (D) as per diagram.

Step 13-B

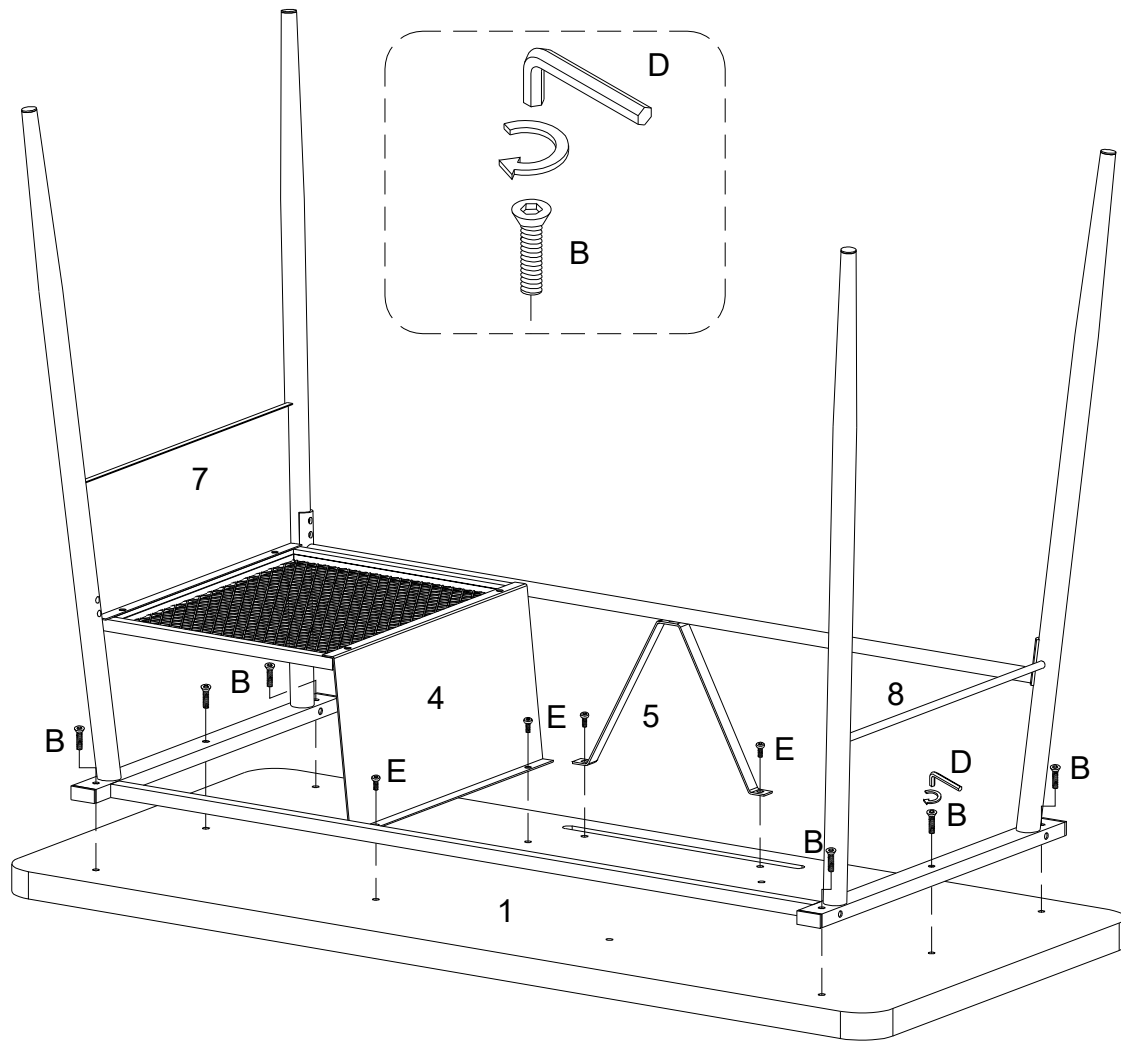

Using bolt (E) secure parts (4,5) to part (1), and using bolt (B) secure parts (7,8) to part (1) with hex key (D) as per diagram.

Note: Fully tighten all bolts.

Step 14

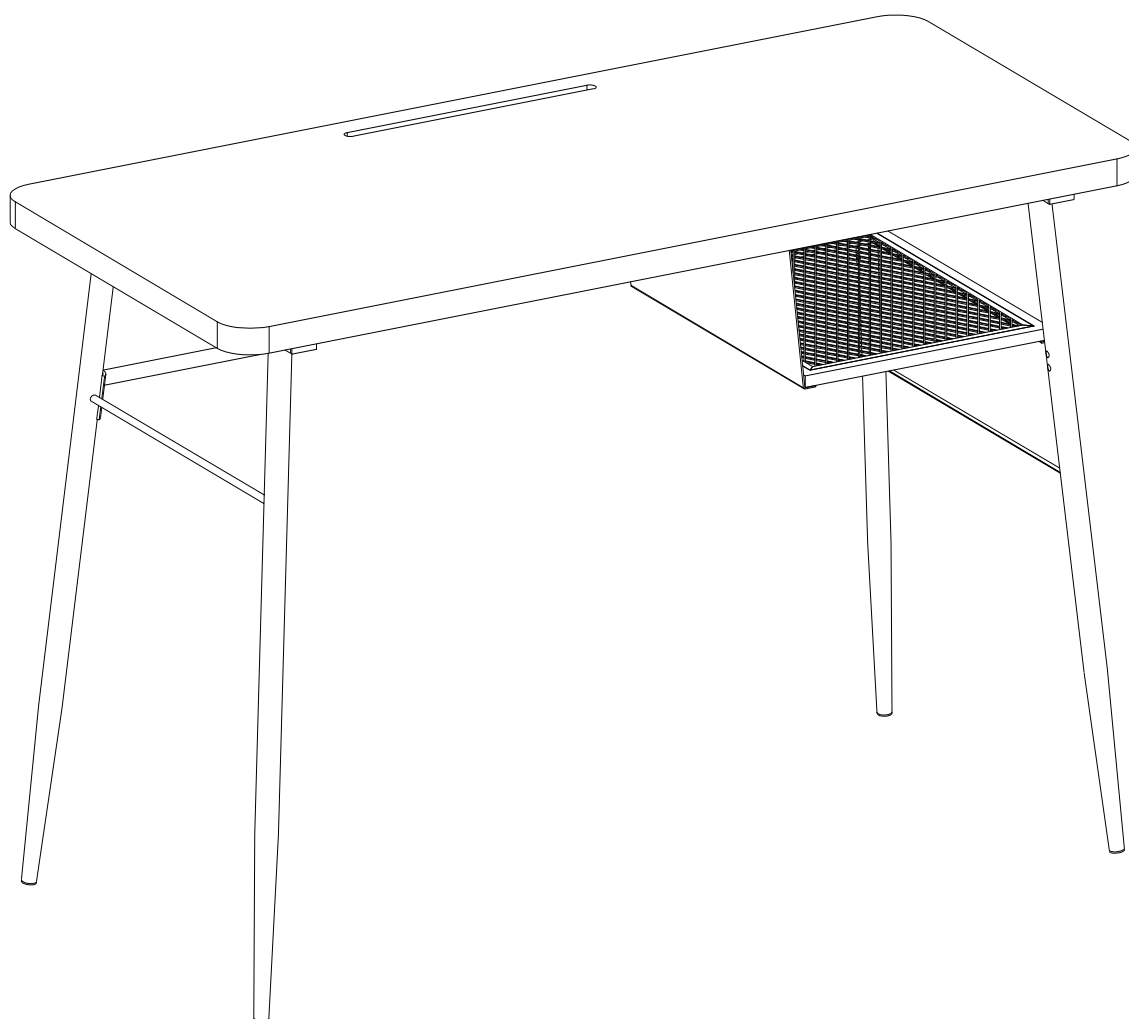

**Version B
Final Assembly**