

Assembly Instructions

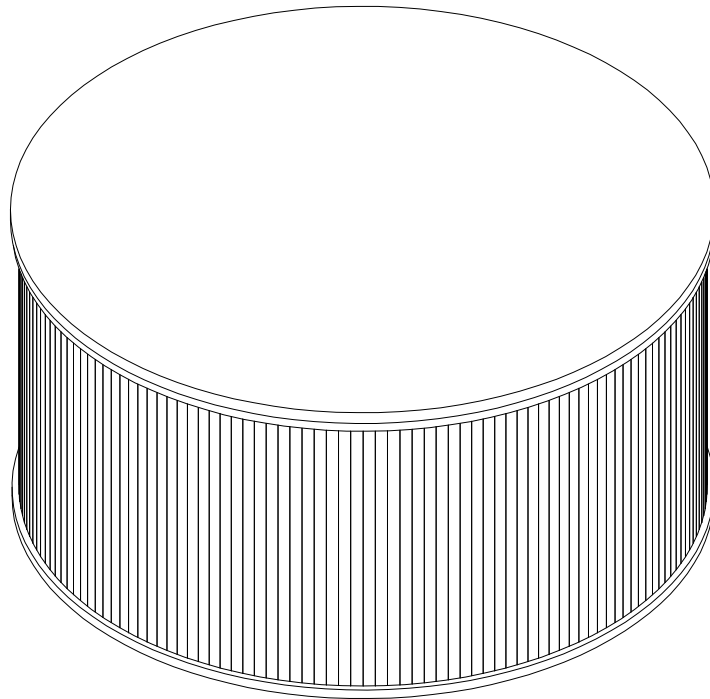

Before Assembly

Tips Before Your Start:

- Remove all wrapping material, including staples & packing straps before you start to assemble.
- DO NOT tighten all screws and bolts until the assembly is completely assembled.
- Keep all hardware parts out of reach of children.

QUICKFIT

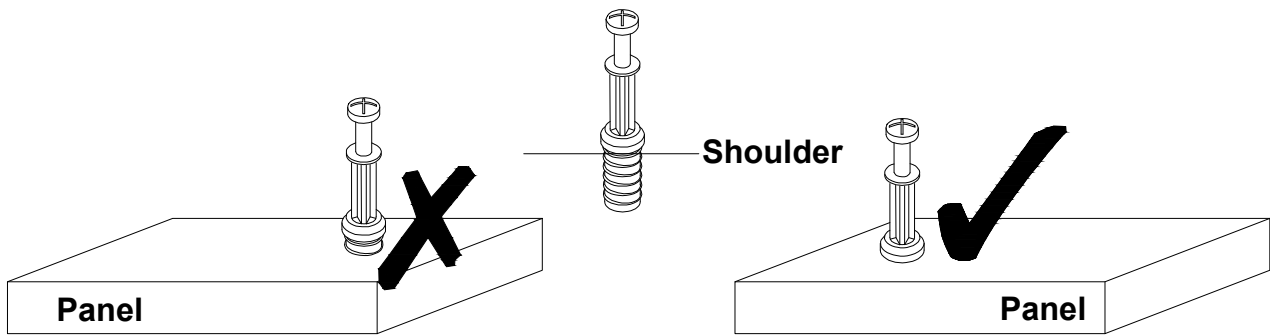

Tighten quickfit until shoulder is flush with panel. Do not overtighten or undertighten.

CAM LOCK

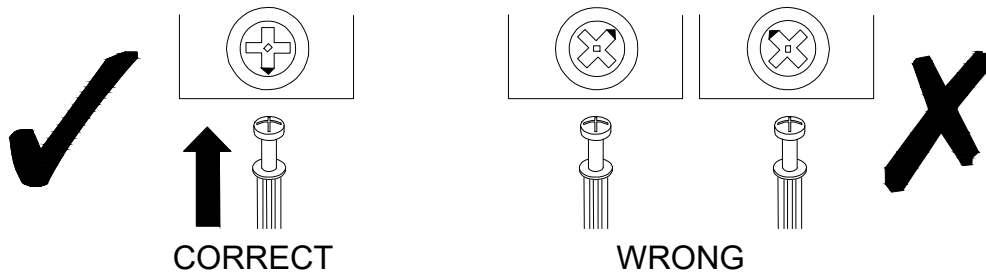

When fitting a cam lock, ensure the starting position is correct before inserting the connecting QUI CKFIT





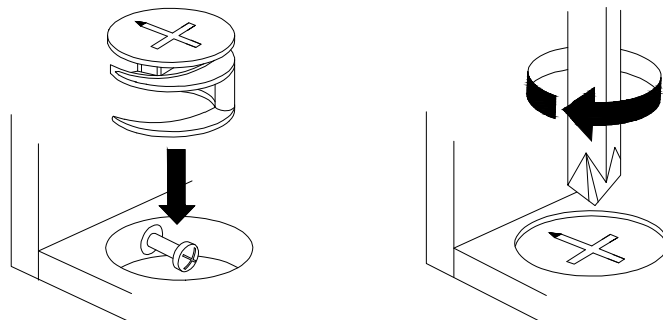

Quickfit head should be in the centre of the cam lock when the two panels are joined.

Cam lock should be inserted before quickfit.

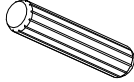
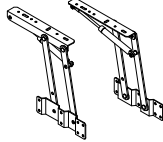

Turn cam lock clockwise to tighten.

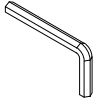
Part List

<p>No. A Quantity:10 Pcs Cam Lock Dowel 8*28mm</p> 	<p>No. B Quantity:10 Pcs Cam Ø15</p> 	<p>No. C Quantity:10 Pcs Sticker Ø20</p> 	<p>No. D Quantity:14 Pcs Dowel 6*30mm</p> 
<p>No. E Quantity:1 Sets Lifting rod</p> 	<p>No. F Quantity:24 Pcs Screw M4*14mm</p> 	<p>No. G Quantity:8 Pcs Screw M6*40mm</p> 	<p>No. H Quantity:1 Pcs Allen Key 4#</p> 
<p>No. I Quantity:4 Pcs Foot Pad Ø20</p> 			

Product structure

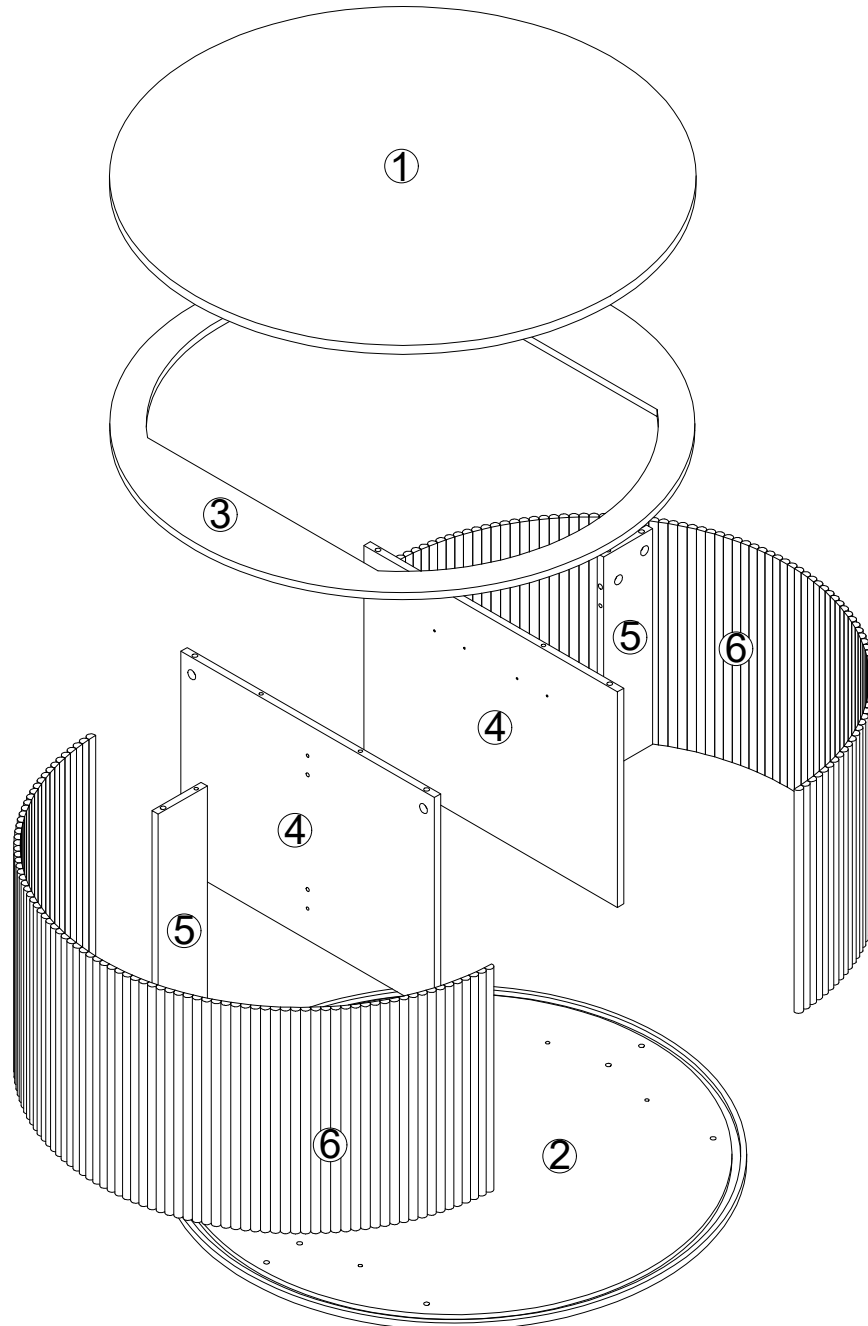

STEP 1

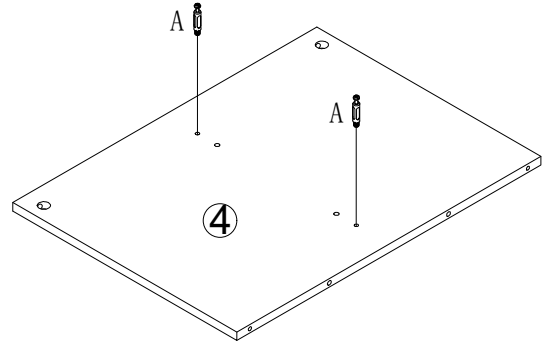
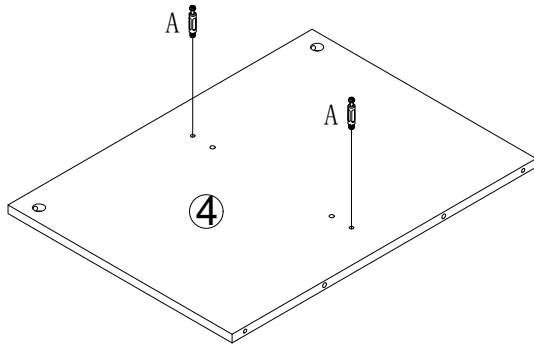

No. A
Quantity: 4 Pcs
8*28mm



STEP 2

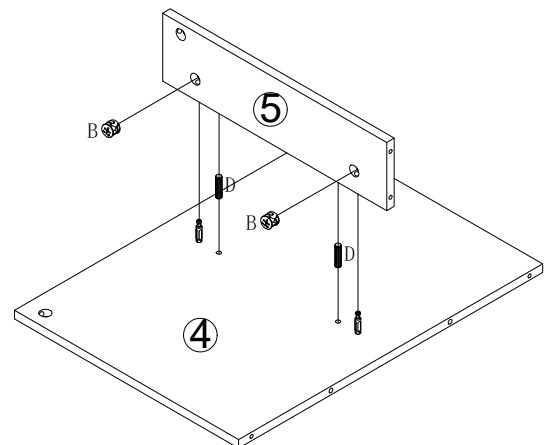
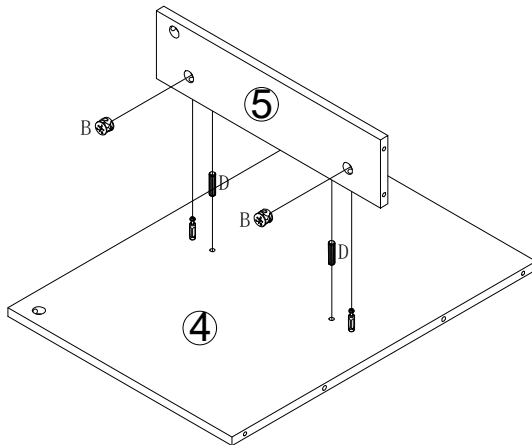

No. B
Quantity: 4 Pcs
Ø15



No. D
Quantity: 4 Pcs
6*30mm

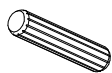

STEP 3

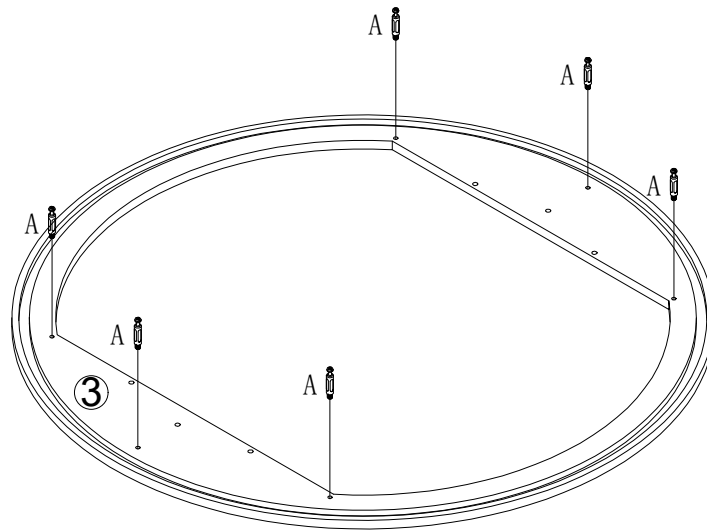

No. A
Quantity: 6 Pcs
8*28mm



STEP 4

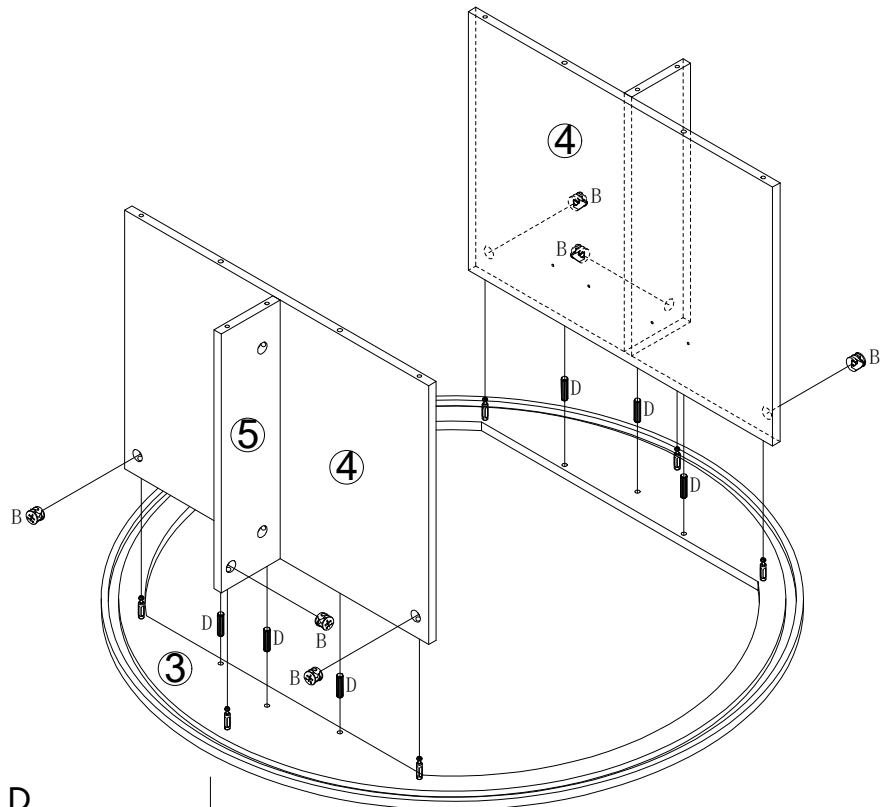

No. B
Quantity: 6 Pcs
Ø15



No. D
Quantity: 6 Pcs
6*30mm

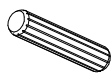

STEP 5

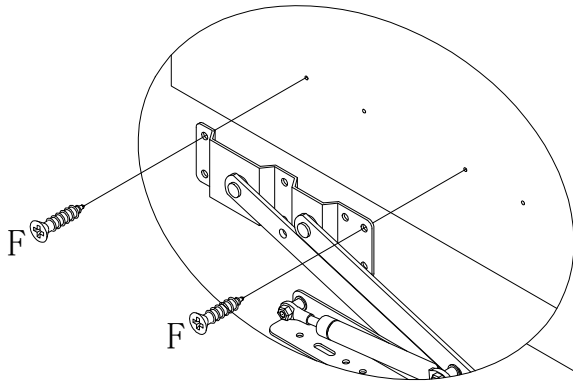

Note: First, align the two holes of the lifting rod with these two guide holes and tighten them with screws.

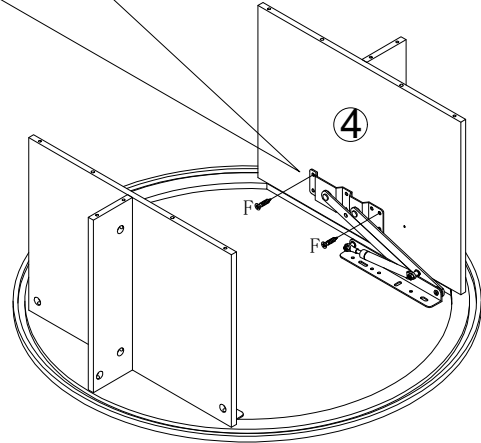

No. E
Quantity: 1 Sets

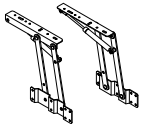

No. F
Quantity: 4 Pcs
M4*14mm



STEP 6

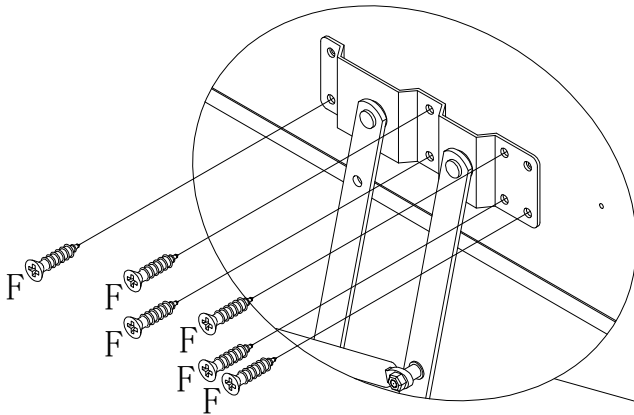

Note: Use screws to reinforce the lifting rod, there are no pilot holes here, the screws can be tightened directly.

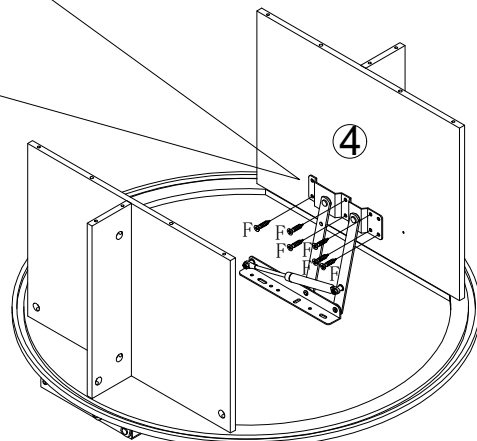

No. F
Quantity: 12 Pcs
M4*14mm



STEP 7

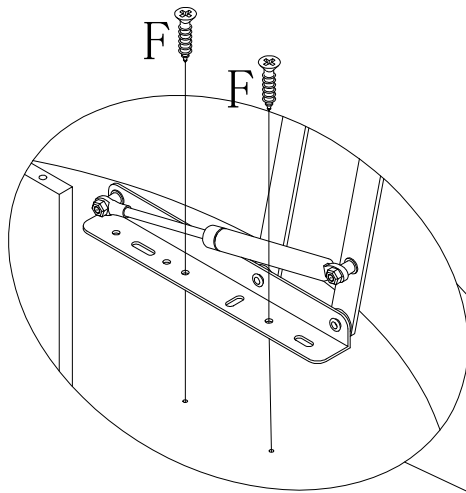

Note: First align the front guide hole, then tighten the screw, and then align the rear guide hole and tighten the screw.

No. F
Quantity: 4 Pcs
M4*14mm

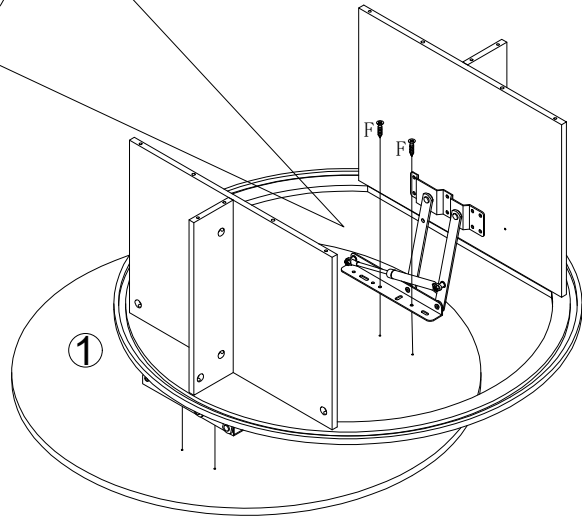

STEP 8

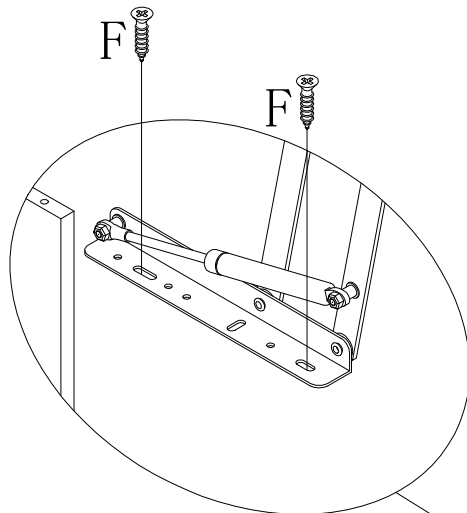

Note: Use screws to reinforce the lifting rod, there are no pilot holes here, the screws can be tightened directly.

No. F
Quantity: 4 Pcs
M4*14mm

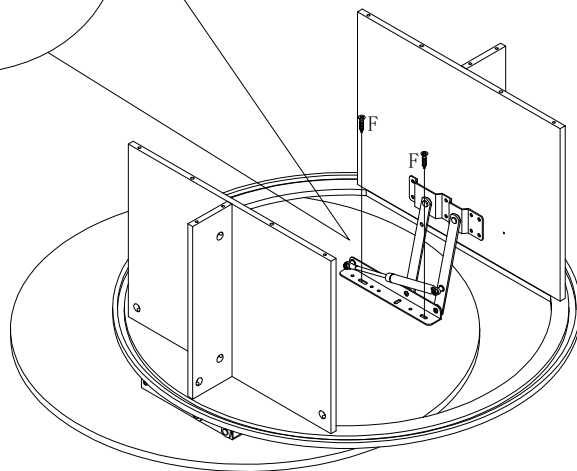

STEP 9

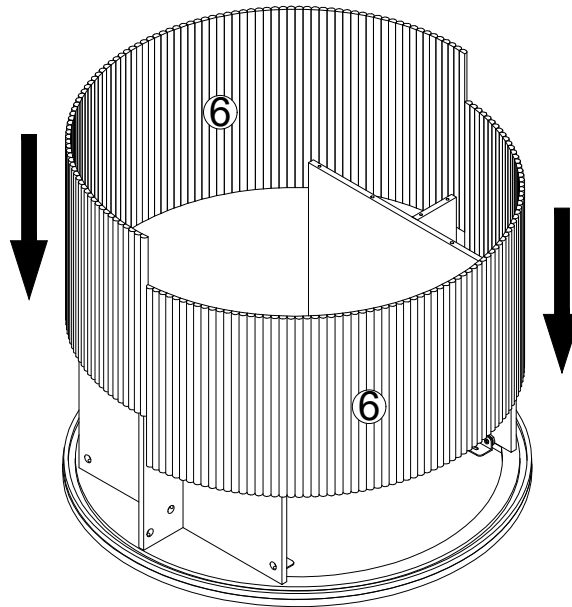

STEP 10

No. D
Quantity: 4 Pcs
6*30mm

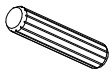

No. G
Quantity: 8 Pcs
M6*40mm



No. H
Quantity: 1 Pcs
4#

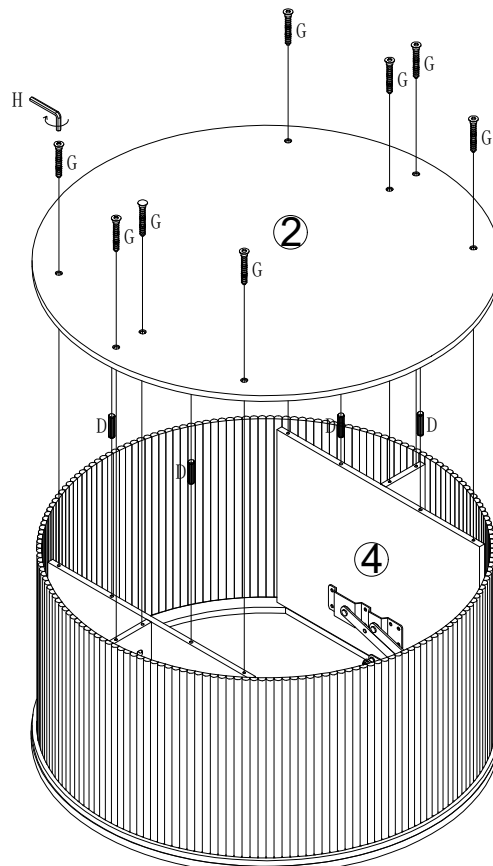

STEP 11

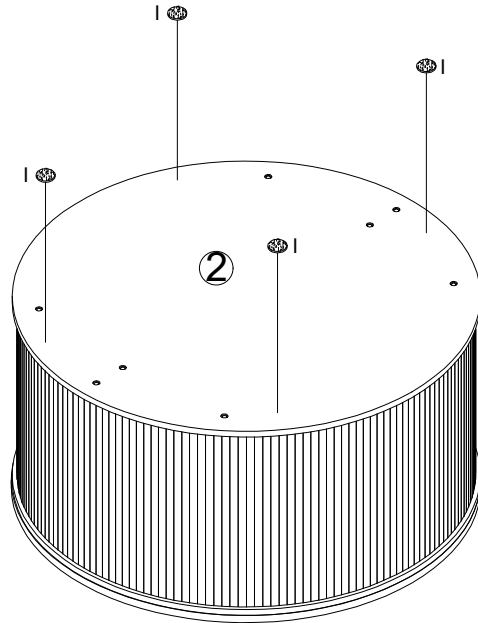

No. 1
Quantity: 4 Pcs
Ø20



STEP 12

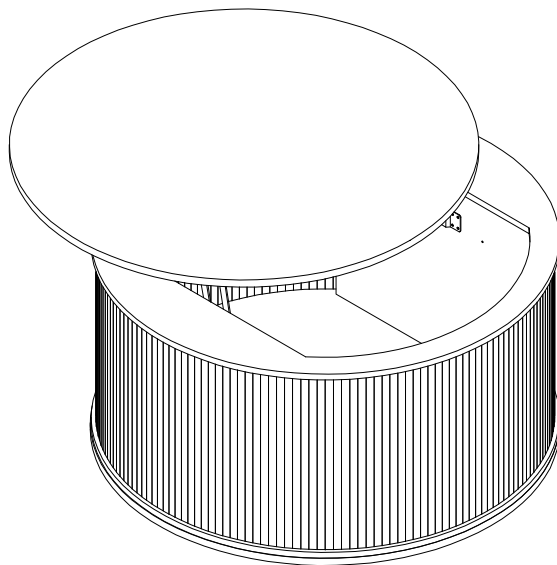

Assembled, flip over.