



Vestil Manufacturing Co.

2999 North Wayne Street, P.O. Box 507, Angola, IN 46703
 Telephone: (260) 665-7586 -or- Toll Free (800) 348-0868
 Fax: (260) 665-1339
 Web: www.vestil.com e-mail: info@vestil.com

HDC-305 SERIES DRUM LIFTERS



NOTE: If your HDC-305 is powered (AC or DC), you should receive a separate owner's manual for the onboard power unit:
[MPU-AC-GEN2](#) (plugs into wall socket)
[MPU-DC-GEN2](#) (battery powered)

Receiving Instructions

After delivery, remove the packaging from the product. Inspect the product closely to determine whether it sustained damage during transport. If damage is discovered, record a complete description of it on the bill of lading. If the product is undamaged, discard the packaging.

NOTE: The end-user is solely responsible for confirming that product design, use, and maintenance comply with laws, regulations, codes, and mandatory standards applied where the product is used.

Technical Service & Replacement Parts

For answers to questions not addressed in these instructions and to order replacement parts, labels, and accessories, call our Technical Service and Parts Department at (260) 665-7586. The department can also be contacted online at <https://www.vestil.com/page-parts-request.php>.

Electronic copies of Instruction Manuals

This instruction manual may be downloaded from <https://www.vestil.com/page-manuals.php>

Table of Contents		Page
Signal Words.....		2
Safety Instructions.....		2
Specifications.....		3
Boom Attachment.....		3
HDC-305-60 Exploded View and Bill of Materials.....		4
HDC-305-72 Exploded View and Bill of Materials.....		5
HDC-305-84 Exploded View and Bill of Materials.....		6
HDC-305-96 Exploded View and Bill of Materials.....		7
Hydraulic System - Autoshifter Foot Pump.....		8
Autoshifter Foot Pump Exploded View and Bill of Materials.....		9 – 10
Inspections and Maintenance (Autoshifter Foot Pump).....		10 – 11
Troubleshooting (Autoshifter Foot Pump).....		11
Electrically Powered Drum Carriers (Options HDC-DC and HDC-AC).....		*12
DC Modular Power Unit Exploded View and Bill of Materials.....		*12
DC Manifold Assembly Exploded View (Item 24 on p. 12).....		*13
12VDC Modular Power Unit Electrical Circuit Diagram.....		*13
12VDC Modular Power Unit Layout.....		*14
AC Modular Power Unit Exploded View and Bill of Materials.....		*15
Electrical Box and Manifold Exploded View (Items 2 and 12 on p. 15).....		*16
115VAC Modular Power Unit Electrical Circuit Diagram.....		*16
115VAC Modular Power Unit Layout.....		*17
Hydraulic Circuit Diagram (Powered Units).....		*17
Operating a Powered HDC-305 (Raising and Lowering the Pivot Arm).....		*18
Bleeding Air from the MPU Hydraulic Circuit.....		*18
Using the Battery Charger (HDC-DC Units Only).....		*19
Using the Boom Attachment.....		19
Lifting Drums (Standard and Powered Units).....		20
Inspections & Maintenance.....		21
Troubleshooting (HDC-DC & HDC-AC).....		22
Labeling Diagram.....		23
Limited Warranty.....		24

*NOTE: Pages 12–19 address the composition and operation of the modular power unit. These pages only apply to powered HDC-305 units manufactured **before** 12-01-2018. Units manufactured on or after 12-01-2018 receive a 2nd generation modular power unit (MPU GEN2). Diagrams and operating instructions for GEN2 power units are provided in

SIGNAL WORDS

SIGNAL WORDS in this manual draw the reader's attention to important safety-related messages.

⚠ DANGER	Identifies a hazardous situation which, if not avoided, <u>WILL</u> result in DEATH or SERIOUS INJURY. Use of this signal word is limited to the most extreme situations.
⚠ WARNING	Identifies a hazardous situation which, if not avoided, <u>COULD</u> result in DEATH or SERIOUS INJURY.
⚠ CAUTION	Indicates a hazardous situation which, if not avoided, <u>COULD</u> result in MINOR or MODERATE injury.
NOTICE	Identifies practices likely to result in product/property damage, such as operation that might damage the product.

SAFETY INSTRUCTIONS

Vestil strives to identify all foreseeable hazards associated with the use of its products. However, material handling is dangerous and no manual can address every conceivable risk. The most effective means for preventing injury is the application of good judgment and common sense by the end-user.

⚠ WARNING

Serious personal injuries might result from improper or careless use of this product.

- Failure to read & understand the entire manual before using or servicing the product is a misuse of the product. Read the manual to refresh your understanding of proper use and maintenance procedures.
- DO NOT attempt to resolve any problem(s) with the product unless you are both authorized to do so and certain that it will be safe to use afterwards.
- DO NOT modify the product in any way UNLESS you first obtain written approval from Vestil. Unapproved modifications might make the lift unsafe to use and automatically void the Limited Warranty (see p. 24).
- DO NOT exceed the capacity of the drum handler. The product is labeled with its capacity. See Label 1153 in See [LABELING DIAGRAM](#) on p. 23. Capacity is reduced to 500 pounds whenever a drum is half-full or less.
- Inspect the product as directed in [INSPECTIONS AND MAINTENANCE](#) on p. 21. ONLY use the drum handler if it is in satisfactory condition. If repairs are necessary, only install manufacturer-approved replacement parts.
- DO NOT change the setting of the pressure relief valve.
- ALWAYS carefully watch the drum handler and drum during use.
- DO NOT use this device UNLESS all product labels are readable and undamaged AND all machine guards are in place. See [LABELING DIAGRAM](#) on p. 23.
- DO NOT ride on the drum handler or use it to move people.
- ALWAYS lower the drum until it is entirely supported by the ground before leaving the unit unattended.
- If part of the hydraulic system is damaged, AVOID contact with pressurized oil. High pressure oil easily punctures skin which can cause injury, gangrene, or death.
- Unload the drum handler before performing any service work on it.
- The unit should always be labeled as shown in the [LABELING DIAGRAM](#) on p. 23. Replace all labels that are damaged, missing, or not easily readable.
- DO NOT use the drum handler if it cannot securely clamp the drum you are trying to handle.
- Only use this product on compacted, improved surfaces that are level and even. Do not traverse sloped terrain.

NOTICE

Proper use, maintenance, and storage are essential for this product to function properly.

- Always use this product in accordance with the instructions in this manual.
- Relieve hydraulic pressure whenever the unit is not in use by fully lowering the carriage.
- Keep the product clean & dry. Lubricate moving parts at least once per month.
- ONLY use manufacturer-approved replacement parts. Vestil is not responsible for issues or malfunctions that result from the use of unapproved replacement parts.
- Do not use brake fluid or jack oils in the hydraulic system. If oil is needed, use an anti-wear hydraulic oil with a viscosity grade of 150 SUS at 100°F, (ISO 32 cSt @ 40°C), or Dexron transmission fluid.
- Contact the manufacturer for SDS information.

SPECIFICATIONS

Documents that provide specifications for HDC-305 series drum lifters are available online to anyone who visits Vestil's website. Specifications include dimensions, net weight, and capacity information. To access the appropriate specifications document, navigate to the HDC-305 webpage at <https://www.vestil.com/product.php?FID=764>. Scroll the page to the entry for the model you purchased. Click the button in the "PDF" column that looks like a pencil inside a blue box. A PDF file will open. This file is the specifications document. Print a copy of the document and keep it with your copy of this manual. The following specifications are provided for convenience only. Refer to your printed specifications document.

PORTABLE HYDRAULIC DRUM CARRIER/ROTATOR - HDC-305-60 APPROX WEIGHT: 408.28 lbs. DOES NOT INCLUDE WEIGHT OF POWER OR PACKAGING!!!

ANY ADDITIONS, DELETIONS, OR OMISSIONS MUST BE CORRECTED ON THIS DRAWING AS THIS DRAWING WILL BE CONSIDERED ALL INCLUSIVE

ALL GRAPHICS PROVIDED ARE FOR REFERENCE ONLY. IF CERTAIN DIMENSIONS ARE CRITICAL PLEASE VERIFY THOSE DIMENSIONS WITH YOUR SALESPERSON

STANDARD FEATURES
 MODEL NUMBER IS HDC-305-60
 CAPACITY IS 800 LBS
 OVERALL WIDTH IS 39 15/16"
 OVERALL LENGTH IS 72 1/2"
 OVERALL HEIGHT IS 80 11/16"
 OUT RIGGER INSIDE DIMENSION IS 32 7/16"
 DRUM RAISED HEIGHT IS 60 1/4"
 (2) 5" X 2" REAR SWIVEL POLY-ON-STEEL CASTERS
 (2) 8" X 2" FRONT RIGID GFN WHEELS
 HAND CRANK DRUM ROTATION (360°)
 FOOT PUMP
 FLOOR LOCK
 DURABLE LIQUID PAINT BLUE FINISH
 LIFTING BOOM ATTACHMENT - MAY BE USED FOR LIFTING OBJECTS USING THE HOOK

SPECIAL FEATURES
 NONE

DIMENSION TOLERANCE ± 1/4"

APPROVAL
 I, THE UNDERSIGNED, AGREE THAT THE PRODUCT AS REPRESENTED SATISFIES DESIGN AND DIMENSION REQUIREMENTS. I ALSO ACKNOWLEDGE MY DUTY TO CONFIRM PRODUCT AND INSTALLATION COMPLIANCE WITH ALL APPLICABLE FEDERAL, STATE AND LOCAL REGULATIONS AND STANDARDS.
UNITS REQUIRING APPROVAL DRAWINGS OR MODIFIED ARE NON-RETURNABLE
 As drawn As marked
 Signed: _____ Date: _____
 Printed Name: _____
 LEAD TIME WILL START UPON RECEIPT OF SIGNED APPROVAL DRAWING

DISTRIBUTOR'S NAME: VESTIL MANUFACTURING		P.O.# X
DRAWN BY: DEY	DATE: 12/05/11	SALES: X
REFERENCE: X	SCALE: 1:28	FILE NAME: 09-007-026
QUOTED LEAD TIME: X	QUOTE # X	

BOOM ATTACHMENT

A removable boom can be pinned to the pivot arm to convert the drum carrier into a shop crane. To install the boom, slide the mounting bracket over the pivot arm. There are pin holes in the pivot arm as well as the bracket. Align the pin holes and insert the clevis pin. Secure the clevis pin with a hitch clip.

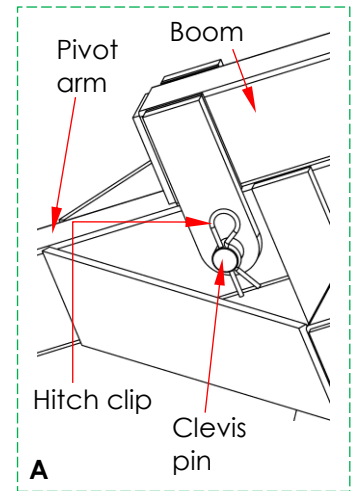
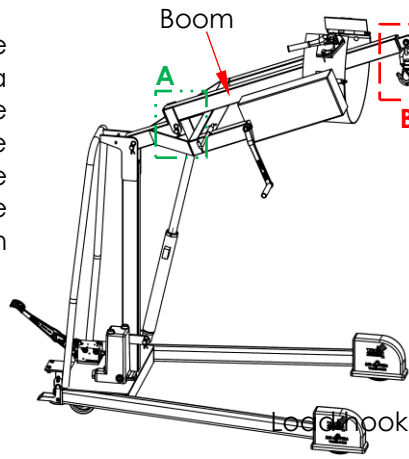
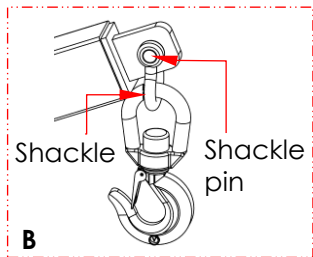

HDC-305-60 EXPLODED VIEW AND BILL OF MATERIALS (09-006-026)

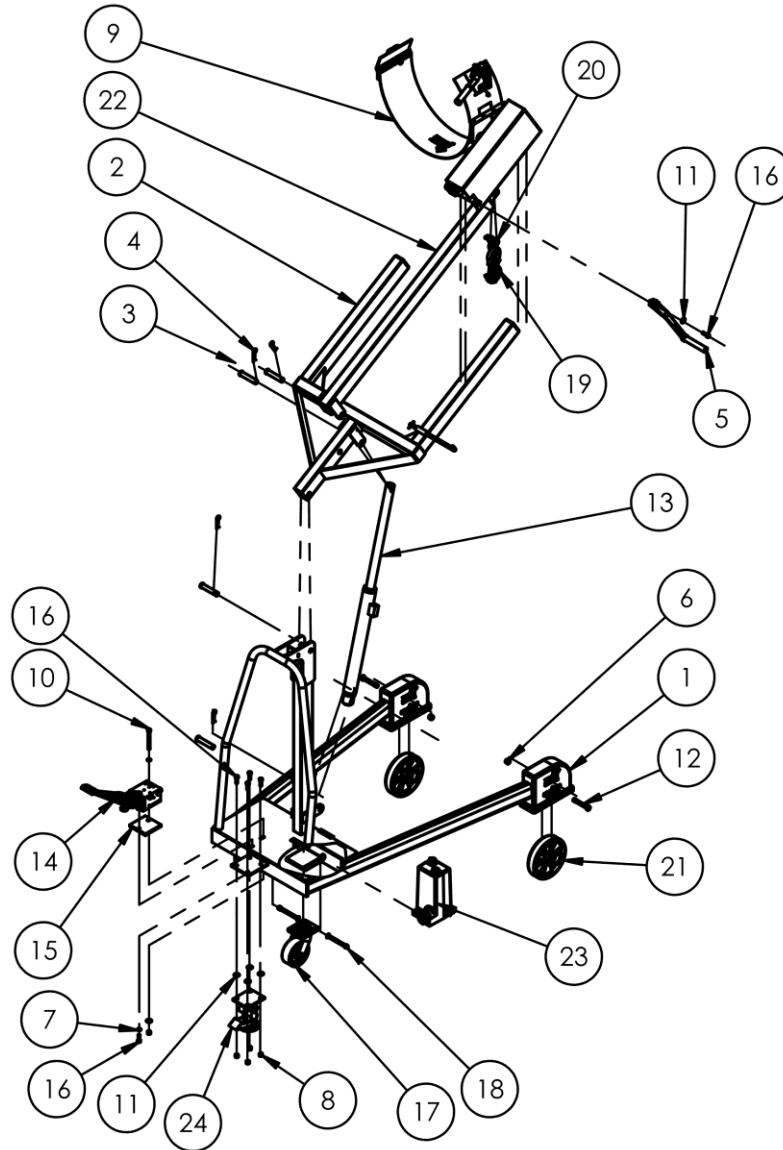

Item	Part no.	Description	Qty.	Item	Part no.	Description	Qty.
1	09-514-015	WELDMENT, BASE W/ MAST	1	13	99-021-904-001	CYLINDER, HYDRAULIC, Ø1 1/2" x 18", RAM STYLE	1
2	09-514-006	WELDMENT, PIVOT ARM	1	14	99-640-005	HYDRAULIC FOOT PUMP, AUTO-SHIFTER, 2-SPEED	1
3	33-112-034	CLEVIS PIN, ZINC PLATED, Ø3/4" X 3 3/4" LG	4	15	01-016-018	PUMP, MANUAL BASE PLATE	1
4	45286	#11 HITCH PIN CLIP, Ø1/8" X 2 5/8 LG	4	16	11107	HEX BOLT, GRADE A, ZINC FINISH, 3/8"-16 x 1-1/4"	6
5	14-025-001	HANDLE, CRANK, 5/8" SQR END	1	17	16-132-021	PU-5/2-S, SWIVEL CASTER	2
6	37030	1/2"-13 NYLON INSERT LOCK NUT, GRADE 2	2	18	99-612-001	PIN, BULLDOG BOLT AND NUT ASSEMBLY	2
7	33622	SPLIT LOCK WASHER, CARBON STEEL, MEDIUM ZINC FINISH, 3/8"	2	19	08-145-001	SPEC HDW, SWIVEL HOOK 2-TON	1
8	37024	NYLON INSERT LOCK NUT, GRADE 2, ZINC FINISH, 3/8"-16	5	20	08-145-010	SPECIALTY HARDWARE, Ø1/2"-2 TON SHACKLE	1
9	09-002-004-008	DRUM SADDLE, ASSEMBLY, HAND CRANK, HDC	1	21	16-132-216	CASTER, WHEEL, GFN-8/2-W	2
10	11119	HEX BOLT, GRADE A, ZINC FINISH, 3/8"-16 x 4"	1	22	09-514-031	WELDMENT, FRAME, BOOM	1
11	33008	FLAT WASHER, LOW CARBON, USS, ZINC PLATED, 3/8"	6	23	99-523-107-1101	WELDMENT, RESERVOIR, 6 x 4 x 9, NATURAL	1
12	16-145-031	BOLT W/GREASE ZERK, 1/2-13 X 3 1/2 LG.	2	24	16-001-452	FLOOR LOCK	1

HDC-305-72 EXPLODED VIEW AND BILL OF MATERIALS (09-006-026-001)

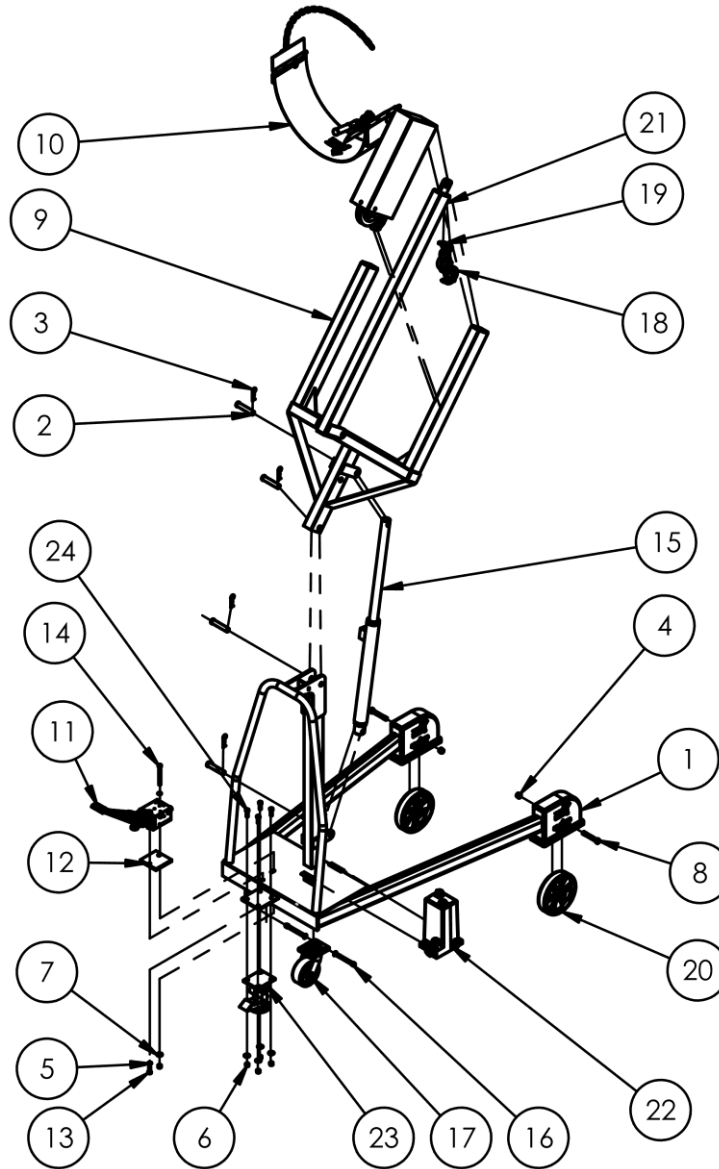

Item	Part no.	Description	Qty.	Item	Part no.	Description	Qty.
1	09-514-155	WELDMENT, BASE W/ MAST	1	13	11105	HEX BOLT, GRADE A, ZINC PLATED, 3/8"-16 X 1"	1
2	33-112-034	CLEVIS PIN, ZINC PLATED, Ø3/4" X 3 3/4" LG	4	14	11119	HEX BOLT, GRADE A, ZINC FINISH, 3/8"-16 x 4"	1
3	45286	#11 HITCH PIN CLIP, Ø1/8" X 2 5/8 LG	4	15	99-021-904-001	CYLINDER, HYDRAULIC, Ø1 1/2" x 18", RAM STYLE	1
4	37030	1/2"-13 NYLON INSERT LOCK NUT, GRADE 2	2	16	99-612-001	PIN, BULLDOG BOLT AND NUT ASSEMBLY	2
5	33622	SPLIT LOCK WASHER, CARBON STEEL, MEDIUM ZINC FINISH, 3/8"	2	17	16-132-021	PU-5/2-S, SWIVEL CASTER	2
6	37024	NYLON INSERT LOCK NUT, GRADE 2, ZINC FINISH, 3/8"-16	5	18	08-145-001	SPEC HDW, SWIVEL HOOK 2-TON	1
7	33008	FLAT WASHER, LOW CARBON, USS, ZINC PLATED, 3/8"	5	19	08-145-010	SPECIALTY HARDWARE, Ø1/2"-2 TON SHACKLE	1
8	16-145-031	BOLT W/GREASE ZERK, 1/2-13 X 3 1/2 LG.	2	20	16-132-216	CASTER, WHEEL, GFN-8/2-W	2
9	09-514-092	WELDMENT ASS'Y, PIVOT ARM	1	21	09-514-031	WELDMENT, FRAME, BOOM	1
10	09-002-004	DRUM SADDLE, ASSEMBLY, PULL CHAIN	1	22	99-523-107-1101	WELDMENT, RESERVOIR, 6 x 4 x 9, NATURAL	1
11	99-640-005	HYDRAULIC FOOT PUMP, AUTO-SHIFTER, 2-SPEED	1	23	16-001-452	FLOOR LOCK	1
12	01-016-018	PUMP, MANUAL BASE PLATE	1	24	11107	HEX BOLT, GRADE A, ZINC FINISH, 3/8"-16 x 1-1/4"	4

HDC-305-84 EXPLODED VIEW AND BILL OF MATERIALS (09-006-038)

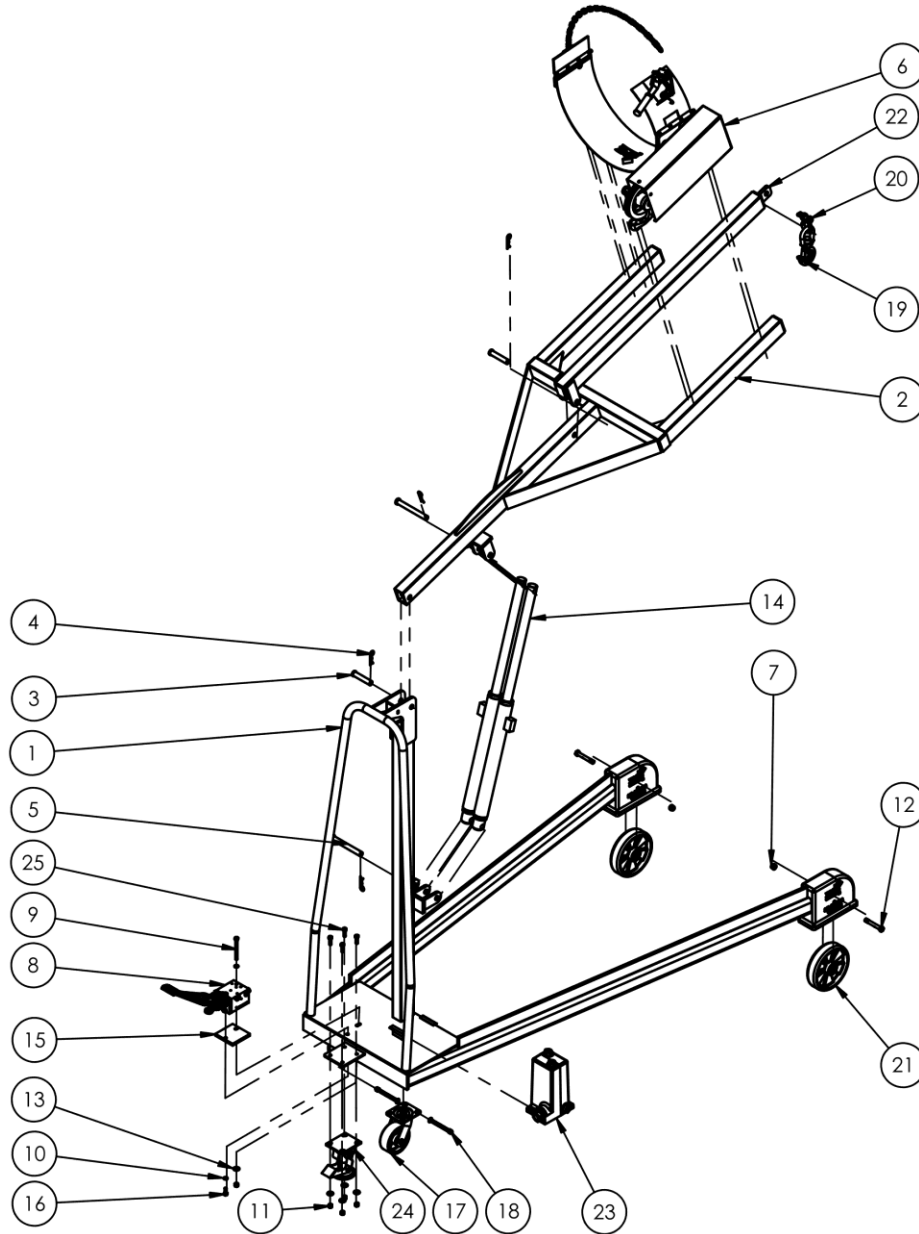

Item	Part no.	Description	Qty.	Item	Part no.	Description	Qty.
1	09-514-038	WELDMENT, BASE W/ MAST	1	14	99-021-904-001	CYLINDER, HYDRAULIC, Ø1 1/2" x 18", RAM STYLE	2
2	09-514-036	WELDMENT ASS'Y, PIVOT ARM	1	15	01-016-018	PUMP, MANUAL BASE PLATE	1
3	33-112-034	CLEVIS PIN, ZINC PLATED, Ø3/4" X 3 3/4" LG	2	16	11105	HEX BOLT, GRADE A, ZINC PLATED, 3/8"-16 X 1"	1
4	45286	#11 HITCH PIN CLIP, Ø1/8" X 2 5/8 LG	4	17	16-132-021	PU-5/2-S, SWIVEL CASTER	2
5	09-112-029	PIN, CLEVIS	2	18	99-612-001	PIN, BULLDOG BOLT AND NUT ASSEMBLY	2
6	09-002-004	DRUM SADDLE, ASSEMBLY, PULL CHAIN	1	19	08-145-001	SPEC HDW, SWIVEL HOOK 2-TON	1
7	37030	1/2"-13 NYLON INSERT LOCK NUT, GRADE 2	2	20	08-145-010	SPECIALTY HARDWARE, Ø1/2"-2 TON SHACKLE	1
8	99-640-005	HYDRAULIC FOOT PUMP, AUTO-SHIFTER, 2-SPEED	1	21	16-132-216	CASTER, WHEEL, GFN-8/2-W	2
9	11119	HEX BOLT, GRADE A, ZINC FINISH, 3/8"-16 x 4"	1	22	09-514-031	WELDMENT, FRAME, BOOM	1
10	33622	SPLIT LOCK WASHER, CARBON STEEL, MEDIUM ZINC FINISH, 3/8"	2	23	99-523-107-1101	WELDMENT, RESERVOIR, 6 x 4 x 9, NATURAL	1
11	37024	NYLON INSERT LOCK NUT, GRADE 2, ZINC FINISH, 3/8"-16	5	24	16-001-452	FLOOR LOCK	1
12	16-145-031	BOLT W/GREASE ZERK, 1/2-13 X 3 1/2 LG.	2	25	11107	HEX BOLT, GRADE A, ZINC FINISH, 3/8"-16 x 1-1/4"	4
13	33008	FLAT WASHER, LOW CARBON, USS, ZINC PLATED, 3/8"	5				

HDC-305-96 EXPLODED VIEW AND BILL OF MATERIALS (09-006-038-001)

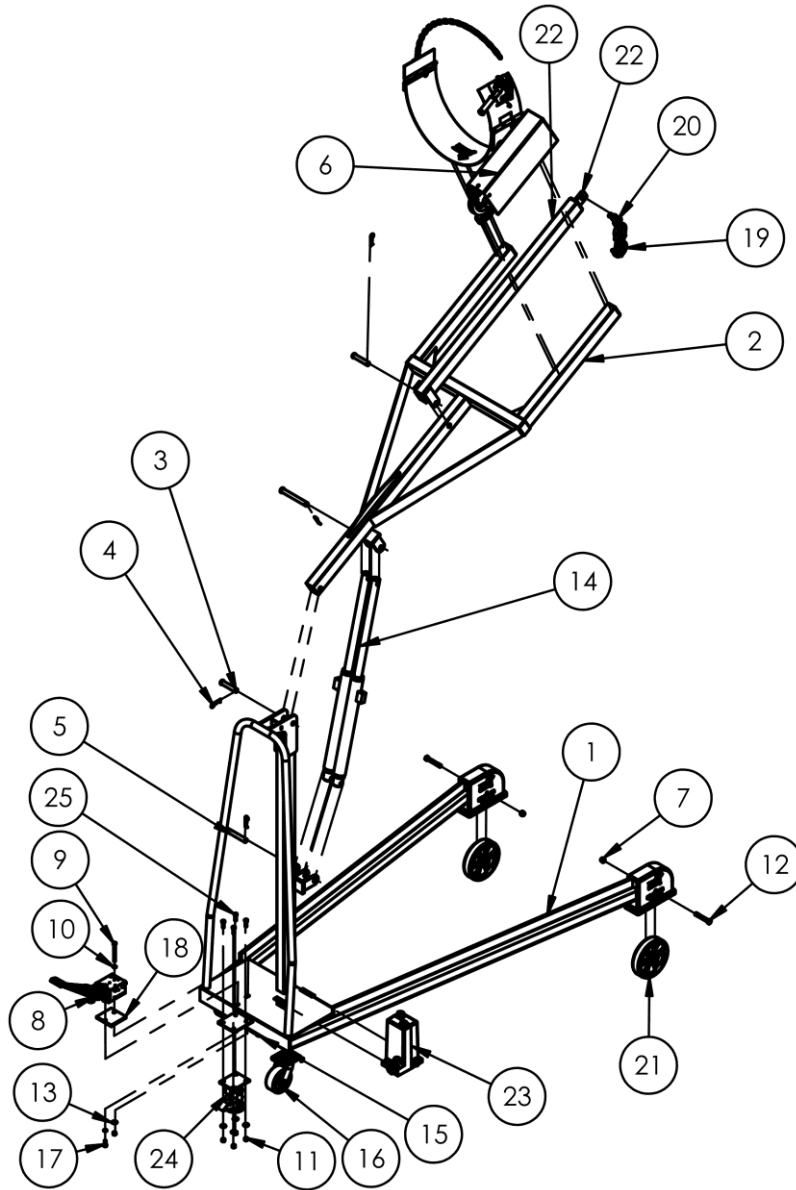

Item	Part no.	Description	Qty.	Item	Part no.	Description	Qty.
1	09-514-158	WELDMENT, BASE W/ MAST	1	14	99-021-904-001	CYLINDER, HYDRAULIC, Ø1 1/2" x 18", RAM STYLE	2
2	09-514-093	WELDMENT ASS'Y, PIVOT ARM	1	15	99-612-001	PIN, BULLDOG BOLT AND NUT ASSEMBLY	2
3	33-112-034	CLEVIS PIN, ZINC PLATED, Ø3/4" X 3 3/4" LG	2	16	16-132-021	PU-5/2-S, SWIVEL CASTER	2
4	45286	#11 HITCH PIN CLIP, Ø1/8" X 2 5/8 LG	4	17	11105	HEX BOLT, GRADE A, ZINC PLATED, 3/8"-16 X 1"	1
5	09-112-029	PIN, CLEVIS	2	18	01-016-018	PUMP, MANUAL BASE PLATE	1
6	09-002-004	DRUM SADDLE, ASSEMBLY, PULL CHAIN	1	19	08-145-001	SPEC HDW, SWIVEL HOOK 2-TON	1
7	37030	1/2"-13 NYLON INSERT LOCK NUT, GRADE 2	2	20	08-145-010	SPECIALTY HARDWARE, Ø1/2"-2 TON SHACKLE	1
8	99-640-005	HYDRAULIC FOOT PUMP, AUTO-SHIFTER, 2-SPEED	1	21	16-132-216	CASTER, WHEEL, GFN-8/2-W	2
9	11119	HEX BOLT, GRADE A, ZINC FINISH, 3/8"-16 x 4"	1	22	09-514-031	WELDMENT, FRAME, BOOM	1
10	33622	SPLIT LOCK WASHER, CARBON STEEL, MEDIUM ZINC FINISH, 3/8"	2	23	99-523-107-1101	WELDMENT, RESERVOIR, 6 x 4 x 9, NATURAL	1
11	37024	NYLON INSERT LOCK NUT, GRADE 2, ZINC FINISH, 3/8"-16	5	24	16-001-452	FLOOR LOCK	1
12	16-145-031	BOLT W/GREASE ZERK, 1/2-13 X 3 1/2 LG.	2	25	11107	HEX BOLT, GRADE A, ZINC FINISH, 3/8"-16 x 1-1/4"	4
13	33008	FLAT WASHER, LOW CARBON, USS, ZINC PLATED, 3/8"	5				

HYDRAULIC SYSTEM - AUTOSHIFTER FOOT PUMP

Your new lift equipment includes a two-speed pump that automatically shifts between speeds based on the output pressure of the hydraulic system. The pump extends and retracts the hydraulic cylinder (part number 99-021-904-001 in the exploded parts drawings on pages 4-7), which raises or lowers the pivot arm and drum saddle/carriage. Internal features of the pump include primary pressure relief and pressure compensated return flow mechanisms, an integrated lowering valve, and an auto-shifting valve assembly. The pump also utilizes replaceable sleeve bearings, valve components, and seals to simplify maintenance requirements and maximize service life.

Operation

Pump speed is automatically adjusted based on the output pressure of the hydraulic system. For example, when the drum saddle is unloaded, pressure in the hydraulic system is low. Under these conditions, the pump operates in high speed mode. Each stroke of the foot pedal pumps approximately 1.2 cubic inches of oil and the pivot arm (and drum) rises rapidly. When a drum is connected to the drum saddle, hydraulic system pressure increases as the drum lifts off of the ground. At pressures in the range of 800-1000 psi the pump automatically shifts to low speed mode. In low speed mode, each stroke pumps approximately 0.44 cubic inches of oil. Less effort is required to move the pedal when the pump is in low speed mode, by the cylinder extends much more slowly, i.e. the pedal has to be pumped many more times to raise the arm.

The pivot arm rises with each stroke of the foot pedal. If too much weight is applied to the saddle, i.e. weight exceeding the capacity, a pressure relief valve opens and directs oil back into the reservoir rather than to the cylinder. As a result, the arm will not rise until the weight of the load is either equal to or less than the capacity of the lifter.

To lower the pivot arm, press the release lever. See Autoshifter item no. 21 on [pages 9 & 10](#)). As the arm lowers, a pressure compensated flow control valve ensures that it lowers at a controlled rate. Do not increase the pressure relief setting more than necessary, i.e. be sure that you do not exceed the pressure rating of the components in the hydraulic system.

Purging Air from the Pump

Whether your pump is new or used, air probably is trapped inside the pump and must be removed. When air is present in the hydraulic system, you might notice that the foot pedal feels spongy. To remove air from the system:

1. Lower the pivot arm.
2. Remove the cover from the modular power unit and unscrew fill plug from the oil reservoir.
3. Disconnect the hydraulic hose from the cylinder port; insert the free end of the hose into the reservoir.
4. Pump the foot pedal several times. Pay close attention to the stream of oil flowing from the hose. Pockets of air will escape as oil flows into the reservoir.
5. Once air is no longer present, reconnect the pump to the cylinder by reattaching the hydraulic hose to the cylinder port. Check all of the hydraulic lines for oil leaks; then return the table to service.
6. Although air has been removed from the pump, air could still be trapped in the cylinder. The next procedure explains how to remove air from the cylinder.

Purging air from the cylinder:

A bleeder screw is located at the top of the cylinder. The bleed screw includes a hose fitting to allow attachment of a small diameter hose. By attaching a hose to the screw, any oil that escapes during the bleeding process can be directed into a container for proper disposal. To bleed air from the cylinder:

1. Lower the pivot arm.
2. Pump the foot pedal once.
3. Carefully open the bleeder screw. The pressure in the system generated by pumping the pedal causes air (and oil) to flow out of the bleeder screw. Pressure will drop as air and oil flow from the cylinder. To pressurize the system, close the bleed screw and pump the pedal once. Open the bleeder screw again to allow more trapped air to escape.
4. Repeat step 3 until air is completely removed from the cylinder, i.e. only oil flows from the bleeder screw.
5. Check all of the hydraulic lines for oil leaks.
6. Return the unit to service.

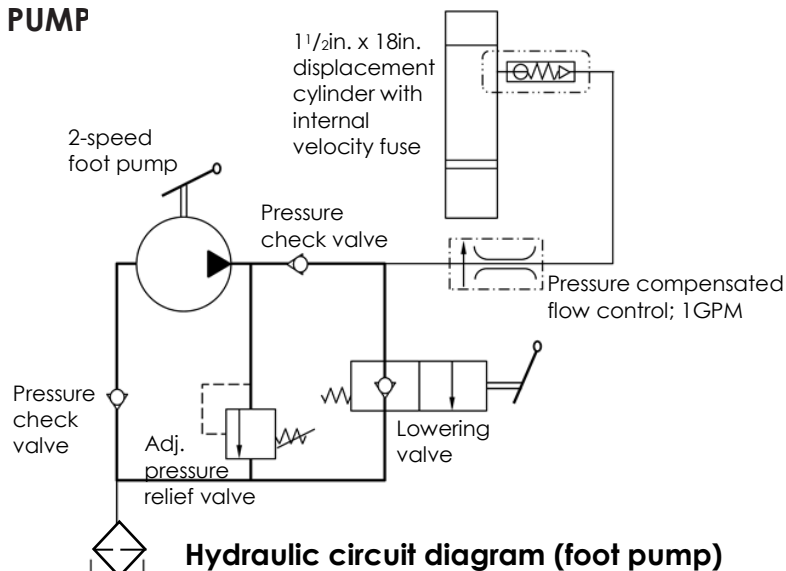

Hydraulic circuit diagram (foot pump)

AUTOSHIFTER FOOT PUMP EXPLODED VIEW [BILL OF MATERIALS ON NEXT PAGE]

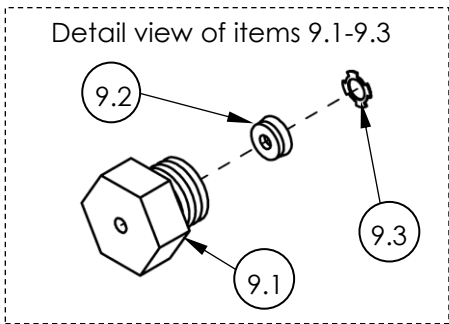

Item	Part no.	Description	Quantity
9.1	99-031-022	Release valve pin seal retainer	1
9.2	99-144-017	Seal, release valve	1
9.3	99-145-127	Star washer	1

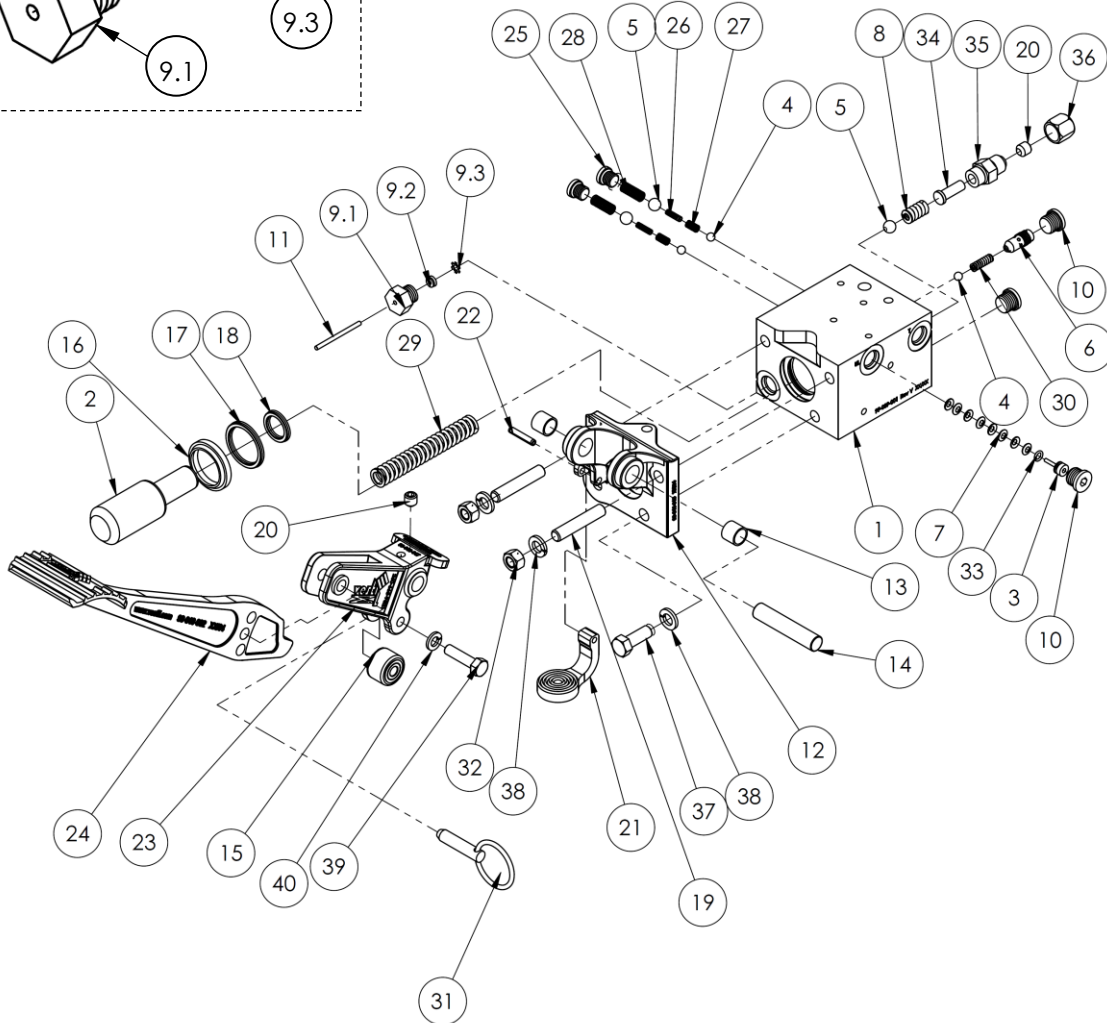

Pump repair kit (part no. 99-136-013)

Part no.	Description	Qty.
99-144-017	Polypack, 1/8" x 3/8" x 1/8"	1
99-145-127	Retaining ring, STPA (star washer)	1
99-031-067	D-wiper, 1 1/4" x 1.625 x 0.187	1
PP-12501250-125B	Seal, 1.25 inner diameter x 0.125 cs	1
99-144-015	U-cup, twin lip rod, 3/4" x 1.000 x 0.125	1
99-144-019	O-ring, 7/32" x 11/32" x 1/16" 70D NBR	1
OR-904-N70	O-ring, #4 SAE port	3
OR-906-N70	O-ring, #6 SAE port	3
01-111-013	Bearing, self-lubricating, 1/2" x 1/2"	2

Ports in pump body ("1" in diagram):

The auto-shifter foot pump has four possible circuit connections.

- 2 pressure ports: marked "P" and "FC/P";
- 2 intake/return ports: marked "T" - one is located on the rear and the other is located on the right side.

Including 2 pressure ports and 2 intake/return ports allows the circuit configuration to be adapted to varied applications. The unused pressure and intake/return ports are each plugged with an SAE #6 port plug.

AUTOSHIFTER FOOT PUMP BILL OF MATERIALS

Item	Part No.	Description	Quantity
1	99-039-001	Body, manual pump, 1.75/0.75 bore	1
2	99-041-001	Piston, pump, 1 1/4" x 3/4"	1
3	99-041-002	Piston, pump, unloader	1
4	99-110-007	Bearing, ball, 1/4"	3
5	99-110-006	Bearing, ball, 3/8"	3
6	99-153-038	Flow control, pressure compensated, 1.0 gal.	1
7	99-114-001	Washer, beveled spring washer	8
8	99-146-008	Spring, relief	1
9	99-653-005	Assembly, release valve packing	1
9.1	99-031-022	Accessory, hydraulic, relief valve pin seal retainer	1
9.2	99-144-017	Seal, release valve	1
9.3	99-145-127	Washer, star	1
10	99-031-066	Plug, SAE #6 port	3
11	99-112-009	Pin, release pin	1
12	99-016-018	Bracket, pivot plate	1
13	01-111-013	Bushing, polygon 1/2" inner diameter x 1/2" long	2
14	99-112-008	Pin, pivot	1
15	20-110-003	Cam roller with seal	1
16	99-031-067	Wiper, 1 1/4" inner diameter x 1 1/2" outer diameter x 3/16"	1
17	99-144-018	Seal, 1 1/4" x 1/8" CS	1
18	99-031-068	U-cup, 3/4" outer diameter x 1/8" CS	1
19	25547	Socket head set screw, black oxide finish, 3/8" – 16 x 2"	2
20	25537	SSS, CP, utility grade, 3/8" – 16 x 3/8"	2
21	99-040-001	Lever, release pedal	1
22	64133	Pin, spring pin, 3/16" – 1" long	1
23	99-016-017	Bracket, pedal link	1
24	99-040-002	Lever, foot pedal, 2-speed, auto-shifter	1
25	99-116-005	Morb hollow hex plug, SAE 4	2
26	99-146-004	Spring, compression, inlet check	2
27	99-146-006	Spring, compression, retainer	2
28	99-146-005	Spring, compression, outlet check	2
29	99-146-009	Spring, compression, return piston	1
30	99-146-007	Spring, release ball	1
31	99-112-049	Pin, detent ring	1
32	36106	Hex nut, grade A, zinc plated, 3/8" – 16	2
33	99-144-019	O-ring, 7/32" inner diameter x 11/32" outer diameter x 1/16" CS	1
34	99-112-050	Pin, spring guide	1
35	99-153-070	Valve, relief	1
36	99-031-069	Cap, #6 JIC	1
37	11105	Hex bolt, grade A, zinc plated, 3/8" – 16 x 1"	1
38	33622	Split lock washer, carbon steel, medium zinc finish, 3/8"	3
39	11057	Hex bolt, grade A, zinc plated, 5/16" – 18 x 1 1/4"	1
40	33620	Lock washer, medium split, 5/16"	1

INSPECTIONS AND MAINTENANCE (AUTOSHIFTER FOOT PUMP)

Before putting the drum carrier into service, create a written record of the appearance and operation of the foot pump, cylinder, and hydraulic hoses. Use the foot pump to extend the cylinder and then retract it by pressing the release lever. Include details in your record about the amount of effort necessary to move the foot pedal as well as how the pump and cylinder look and sound during extension and retraction. This record establishes satisfactory condition of the pump and cylinder. During subsequent inspections, compare observations to this record to determine whether the pump and cylinder are in satisfactory condition.

Unload the drum carriage and lower the pivot arm before inspecting the pump or performing maintenance on it.

(A) Before Each Use Check For Any of the Following Conditions. Do not return the unit to service unless it is in satisfactory condition.

- Oil leaks from the pump, hoses, hose fittings, etc.
- Pinched or chafed hoses
- Unusual noise or binding

(B) Monthly

- Determine the oil level. Oil should be 1" to 1-1/2" below the top of the reservoir/tank with the pivot arm fully lowered. Add oil, if necessary.
- Check for oil leaks. Resolve the issue as described in "Troubleshooting" section.
- Check the hydraulic system for worn or damaged hoses. Replace damaged hoses as necessary.
- Cycle the deck and listen for unusual noise. See [TROUBLESHOOTING \(AUTOSHIFTER PUMP\)](#).

(C) Yearly

Change the oil at least once a year or sooner if it darkens, is gritty, or appears milky. Milky appearance indicates the presence of water. Replace the oil with AW-32 hydraulic fluid or its equivalent.

TROUBLESHOOTING (AUTOSHIFTER FOOT PUMP)

Issue	Explanation	Remedy
1. Pivot arm does not rise despite pumping pedal	a. Too much weight applied to the saddle (load exceeds capacity). b. Too little oil in hydraulic system c. Pinched hydraulic hose d. Relief valve pressure setting too low	a. Remove enough of load that weight of load is within capacity of carrier b. Add oil until level is within one inch of top of reservoir c. Correct as appropriate d. Increase pressure setting as necessary, but NEVER more than 3,000psi
2. A lot of force is required to pump the pedal and the arm does not rise or rises slowly	e. Debris under pressure relief valve f. Debris under inlet check valve	e. Remove, disassemble, clean (with mineral spirits or kerosene), reassemble and reinstall pressure relief valve assemblies. f. Remove, disassemble, clean (with mineral spirits or kerosene), reassemble and reinstall check valve assemblies.
3. Pivot arm rises only when unloaded or pedal pumped rapidly OR I can pump the pedal but the arm does not move.	g. Pump is air locked h. Debris on seat of inlet check valve i. Pressure setting of relief valve needs adjustment j. Debris on seat of relief valve	g. Remove air from the pump. See "Purging air from the pump," p. 8 . h. Remove inlet check valve and clean debris from valve seat (the bottom of the cavity in pump body that valve fits into). i. Increase pressure setting as necessary, but NEVER more than 3,000psi. j. Remove relief valve and clean debris from valve seat in pump body.
4. Arm rises during the down stroke of the pedal, but lowers during the upstroke.	k. Outlet check valve stuck in open position	k. Remove, disassemble, clean (with mineral spirits or kerosene), reassemble and reinstall outlet check valve assemblies.
5. Pivot arm rises and maintains elevation, but have to pump the pedal a million times	l. Autoshifter valve stuck in closed/deactivated position (piston out).	l. Remove port plug from port marked "UL" (on pump body); then remove piston. Inspect piston and springs
6. Pivot arm rises very slowly	m. Autoshifter valve stuck in open/activated position (piston in)	m. Remove port plug from port marked "UL" (on pump body); then remove piston. Inspect piston and springs
7. Pump pedal feels spongy or pivot arm rises in jerks	n. Oil level is low o. Air present in pump and/or cylinders	n. Add oil until level is within 1in. of top of reservoir. o. Purge air by following "Purging air from the pump" and "Purging air from the cylinder" on p. 8 .
8. Pivot arm lowers very slowly	p. Flow control valve obstructed	p. Remove valve and inspect for debris or non-operating spool
9. Arm lowers too rapidly	q. Flow control valve obstructed or not moving freely	q. Remove valve and inspect for debris or non-operating spool
10. Pivot arm rises part way and then stops	r. Air trapped in small pump chamber	r. Perform "Purging air from the pump" on p. 8 .

ELECTRICALLY POWERED DRUM CARRIERS (OPTIONS HDC-DC AND HDC-AC)

A modular power unit (MPU) provides power to raise and lower the pivot arm.

- Option HDC-DC utilizes a 12V battery with an onboard battery charger.
- Option HDC-AC is an AC powered MPU's that must be connected to an electrical outlet.

DC MODULAR POWER UNIT EXPLODED VIEW AND BILL OF MATERIALS

Refer to MPU-GEN2 manual if unit manufactured on or after 12-01-2018.

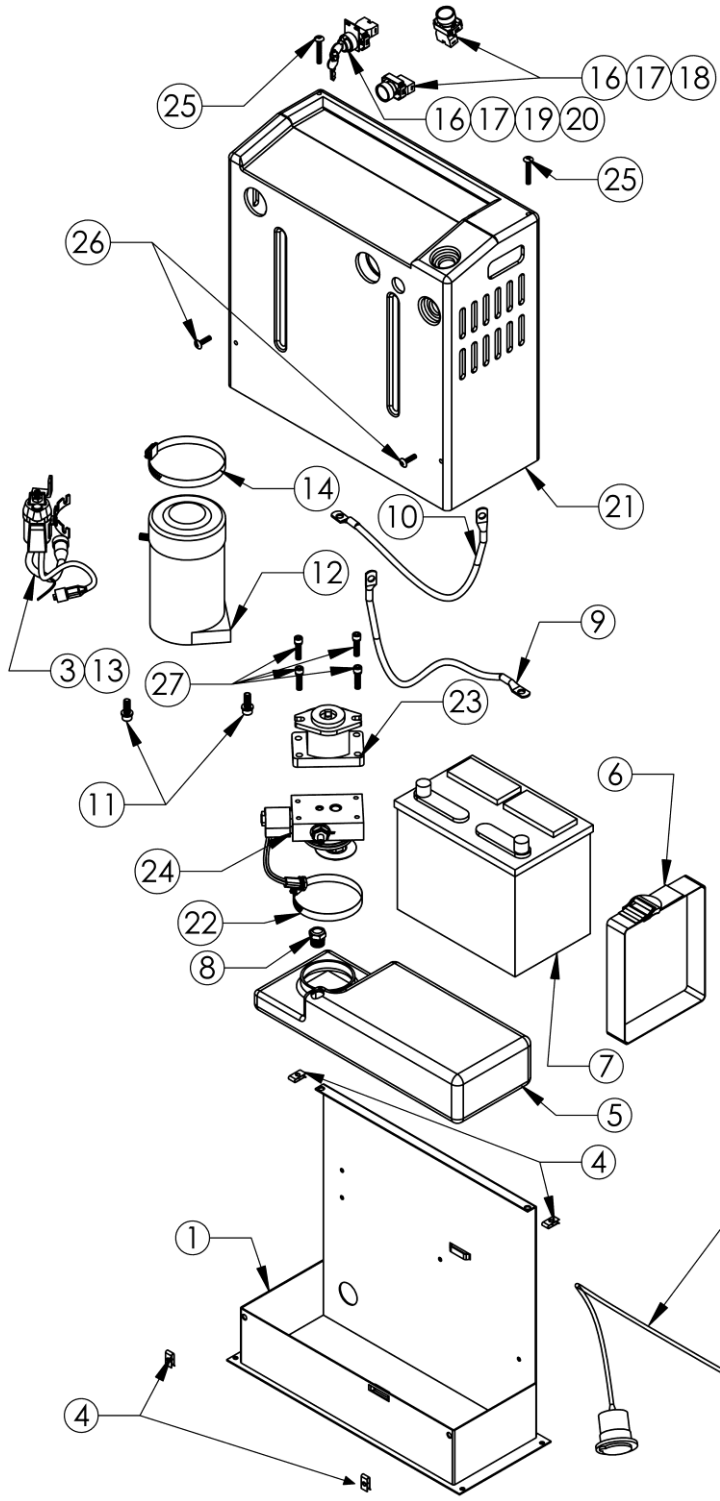

Item	Part no.	Description	Quantity
1	99-016-933	Base bracket	1
2	21-034-008	Charger (Soniel)	1
3	01-033-024	24", 18/3, 4-pin plug	1
4	37927	Tinnerman clip	4
5	99-023-001	Reservoir	1
6	99-034-013	Battery strap	1
7	24DC36	Battery	1
8	BV-48	Breather	1
9	15-533-013	Cable, battery, 23" black	1
10	15-533-014	Cable, battery, 23" red	1
11	23305	3/8" - 16 x 1" utility grade bolt	2
	33688	3/8" high collar lock washer	2
	33008	3/8" flat washer	2
12	99-135-011	4", 12VDC motor w/ tang dr.	1
13	15-022-004	12V start solenoid relay	1
14	HS64	Worm gear hose clamp	1
15	BG-12V	Battery gauge	1
16	ZB2BZ009	Base, contact block	3
17	ZB2BE101	Contact block N.O.	3
18	ZB2BA2C	Operator, black, non-illuminated	2
19	ZB2BG4C	Key switch, 2-position	1
20	01-134-007	Legend, ON - OFF	1
21	091802JY	Fiberglass cover	1
22	HS52	Clamp, worm gear	1
23	01-143-906	Pump	1
24	01-627-010	Manifold assembly (exploded view on p. 13)	1
25	29201	1/4in. - 20 x 1 3/4in. TPHMS zinc-plated	2
26	29185	1/4in. - 20 x 1in. TPHMS zinc-plated	2
27	23255	SHCS utility grade	4
	33687	High collar lock washer	4
28	152400-03	Molded cord	1
29	150CCTM.OEM	Connector, charge	1
30	3MT ST3540	1in. hook and loop press	10"

DC MANIFOLD ASSEMBLY EXPLODED VIEW (ITEM 24 ON P.12)

Refer to MPU-GEN2 manual if your unit was manufactured on or after 12-01-2018.

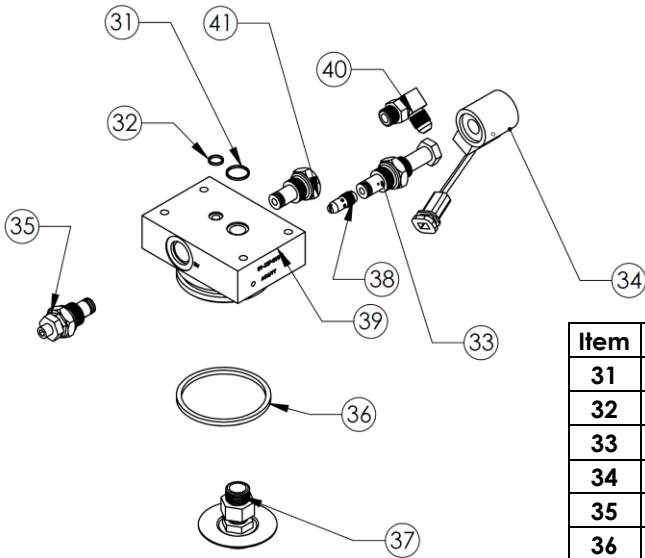

Item	Part no.	Description	Qty.
31	568-015-BN70	O-ring	1
32	568-011-BN70	O-ring	1
33	99-153-058	Valve, cartridge, normally closed	1
34	99-034-010	Coil with weather-tite plug	1
35	99-153-006	Valve, pressure relief	1
36	568-334-BN70	O-ring	1
37	99-531-005	Filter	1
38	99-153-038	Flow control, 1.0GPM	1
39	01-127-010	Manifold	1
40	6801-06-06-NWO	MJ-MAORB 90 degree	1
41	99-153-011	Valve, check	1

12VDC MODULAR POWER UNIT ELECTRICAL CIRCUIT DIAGRAM

Refer to MPU-GEN2 manual if your unit was manufactured on or after 12-01-2018.

NOTE: Overcurrent & short-circuit protection as well as system disconnect must be provided.

Battery Charge Indicator (OPTIUM)

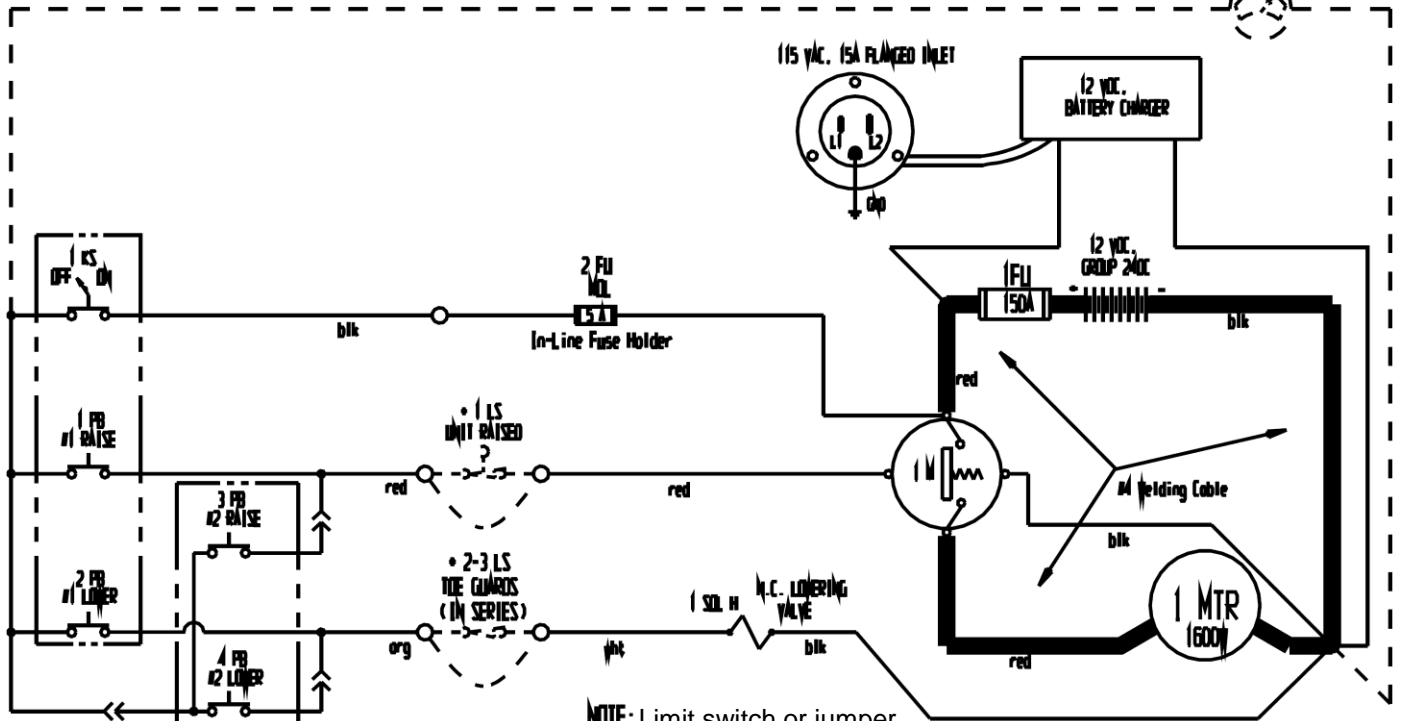

NOTE: Limit switch or jumper wire used where applicable.

12VDC MODULAR POWER UNIT LAYOUT (PART 1 OF 2)

Refer to MPU-GEN2 manual if your unit was manufactured on or after 12-01-2018.

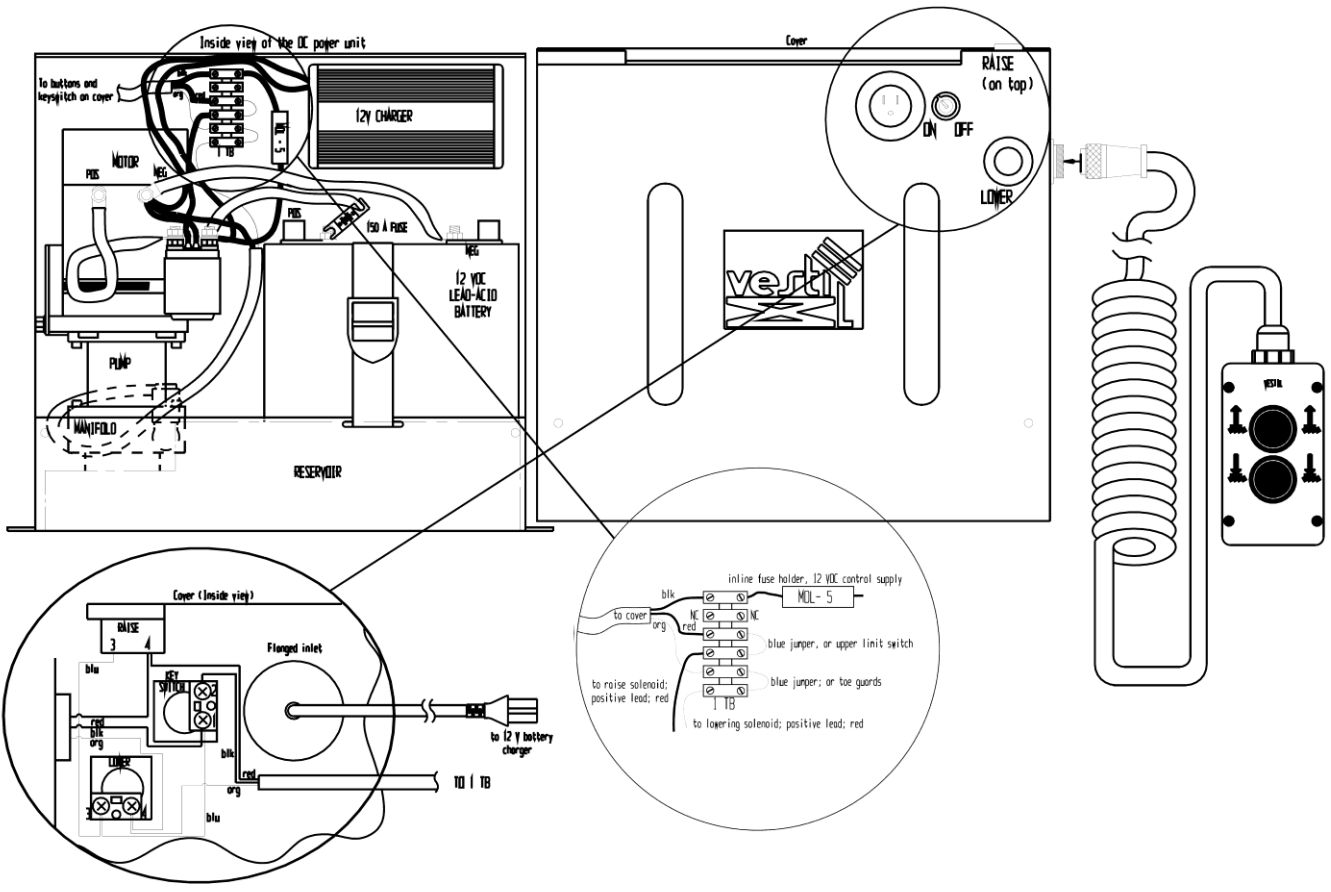

12VDC MODULAR POWER UNIT LAYOUT (PART 2 OF 2)

Refer to MPU-GEN2 manual if your unit was manufactured on or after 12-01-2018.

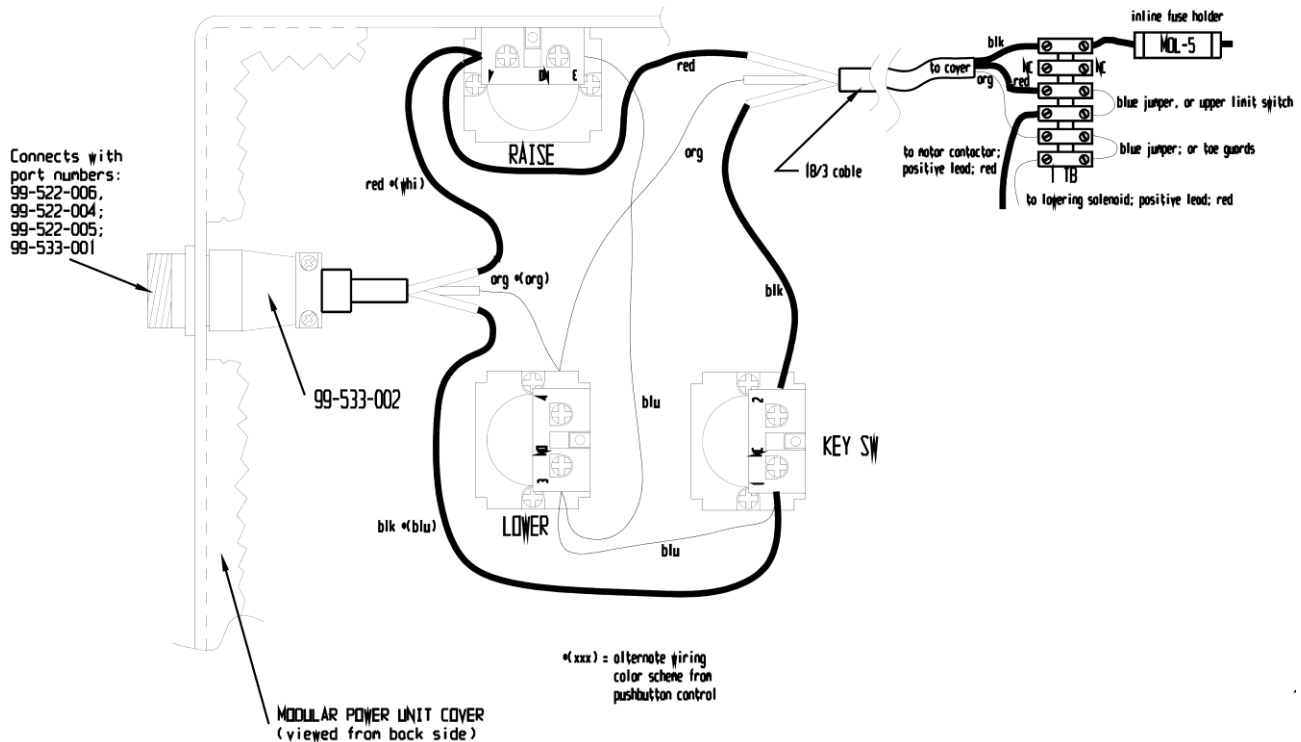

AC MODULAR POWER UNIT EXPLODED VIEW AND BILL OF MATERIALS

Refer to MPU-GEN2 manual if your unit was manufactured on or after 12-01-2018.

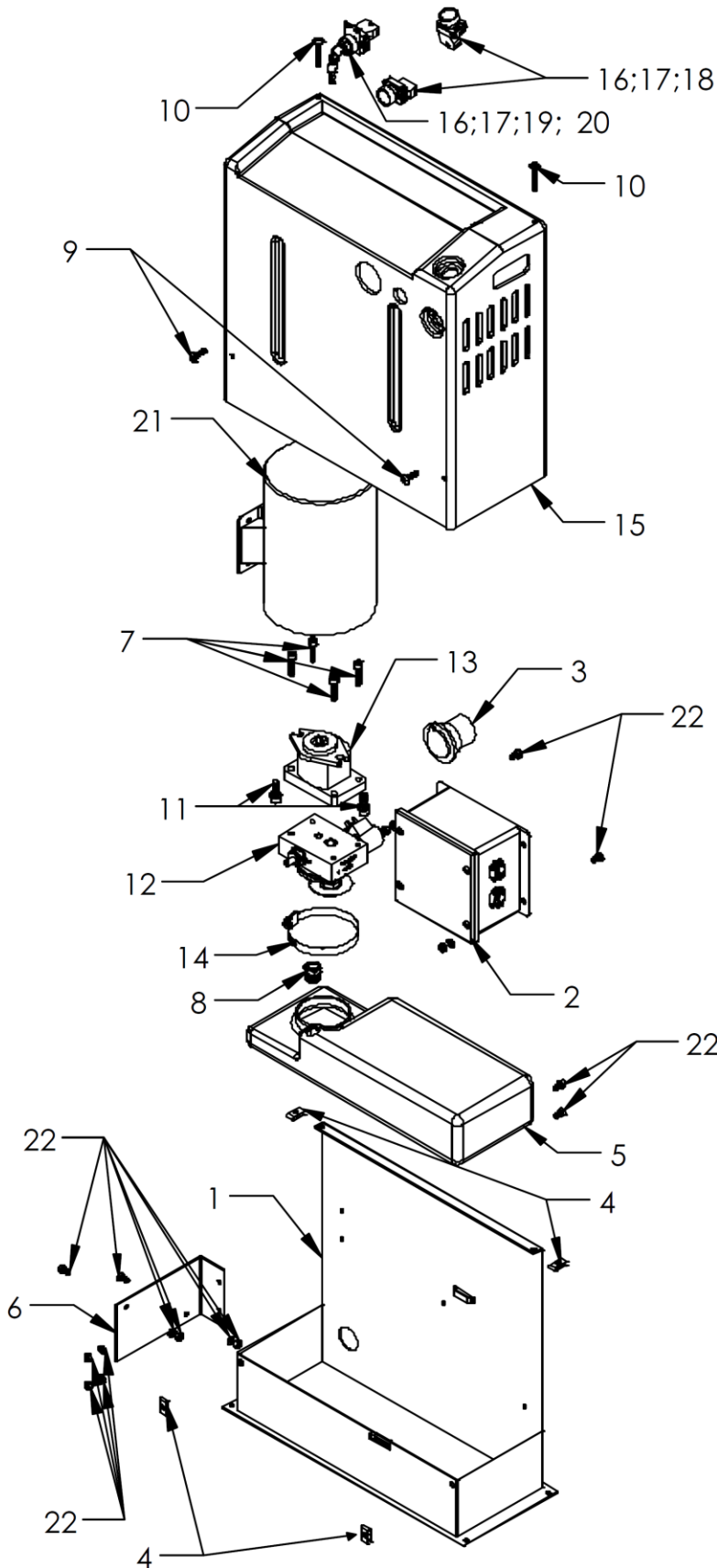

Item	Part no.	Description	Quantity
1	99-016-933	Base bracket	1
2	21-034-008	Electrical box (see FIG. 6B)	1
3	21-034-005	AC adaptor plug	1
4	37927	Tinnerman clip	4
5	99-023-001	Reservoir	1
6		Motor brace	1
7	23255 33687	5/16" - 18 x 1" utility grade bolt	4
		5/16" high collar lock washer	4
8	BV-48	Breather	1
9	29185	1/4" - 20 x 1" TPHMS z-plated screw	1
10	29201	1/4" - 20 x 1 3/4" TPHMS z-plated screw	1
11	23305 33688 33008	3/8" - 16 x 1" utility grade bolt	2
		3/8" high collar lock washer	2
		3/8" flat washer	2
12	01-627-010	Manifold (see FIG. 6C)	1
13	01-143-906	Pump	1
14	HS52	Worm gear hose clamp	1
15	091802JY	Fiberglass cover	1
16	ZB2BZ009	Base, contact block	3
17	ZB2BE101	Contact block N.O.	3
18	ZB2BA2C	Operator, black, non-illuminated	2
19	ZB2BG4C	Key switch, 2-position	1
20	01-134-007	Legend, ON - OFF	1
21			1
22	HS52	Clamp, worm gear	1
23	01-143-906	Pump	1
24	01-627-010	Manifold assembly (exploded view on p. 12)	1
25	29201	1/4in. - 20 x 1 3/4in. TPHMS zinc-plated	2
26	29185	1/4in. - 20 x 1in. TPHMS zinc-plated	2
27	23255 33687	SHCS utility grade High collar lock washer	4
			4
28	152400-03	Molded cord	1
29	150CCTM.OEM	Connector, charge	1
30	3MT ST3540	1in. hook and loop press	10"

ELECTRICAL BOX AND MANIFOLD EXPLODED VIEW (ITEMS 2 AND 12 ON P. 15)

Refer to MPU-GEN2 manual if your unit was manufactured on or after 12-01-2018.

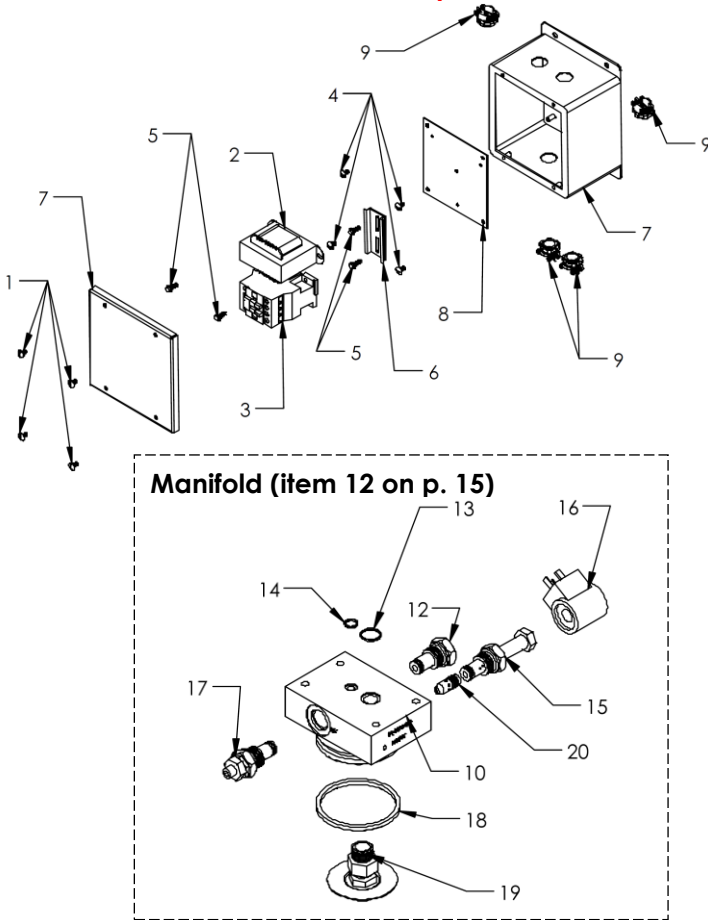

Item	Part no.	Description	Qty.
1	71616	10 – 32 x 5/8" TSHMS screws	4
2	01-129-001	Transformer	1
3	132560	Motor contactor	1
4	27531	10 – 32 x 1/4" PSHMS zinc-plated screws	4
5	32028	8 – 18 x 1/2" HWH TEK drill and tap screws	4
6	TB-TRACK	Aluminum din rail	3"
7	01-029-006	5/16" – 18 x 1" utility grade bolt	1
8	AB66JP	6" x 6" enclosure plate	1
9	C500	3/8" (1/2" knockout) Romex 2-screw NM clamp connector	4
10	01-127-010	LHL standard manifold, 3" boss	1
11	6801-06-06-NOW	3/8" – 16 x 1" utility grade bolt	2
12	99-153-011	Check valve	1
13	568-015-BN70	O-ring	1
14	568-011-BN70	O-ring	1
15	99-153-015	Normally closed cartridge valve	1
16	99-034-008	24VAC coil	1
17	99-153-006	Pressure relief valve	1
18	568-334-BN70	O-ring	1
19	99-531-005	Filter	1
20	99-153-038	Flow control, 1.0GPM	1

115VAC MODULAR POWER UNIT ELECTRICAL CIRCUIT DIAGRAM

Refer to MPU-GEN2 manual if your unit was manufactured on or after 12-01-2018.

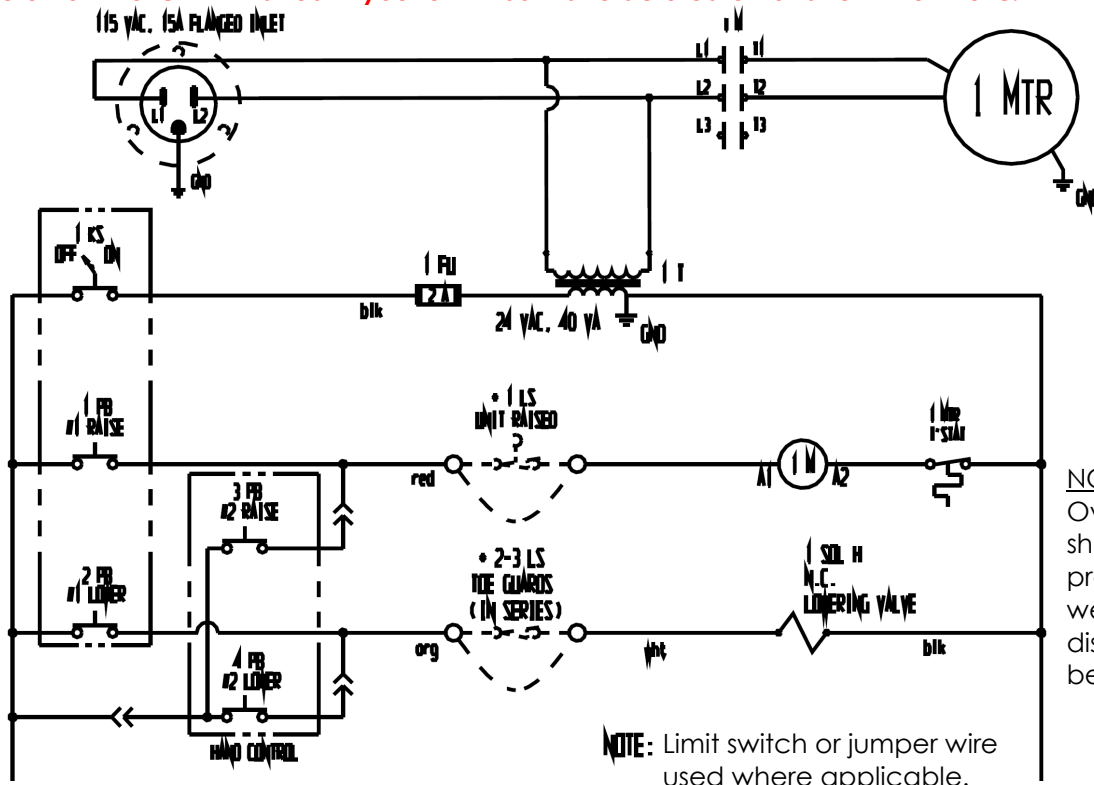

NOTE: Overcurrent & short-circuit protection as well as system disconnect must be provided.

NOTE: Limit switch or jumper wire used where applicable.

OPERATING A POWERED HDC-305 (RAISING & LOWERING THE PIVOT ARM)

NOTE: If your HDC was manufactured on or after Dec. 1, 2018, see the NOTE in the Table of Contents on the cover page. Refer to the separate MPU-GEN2 manual provided with this manual.

The drum carriage of electrically powered units is controlled by a handheld controller as well as pushbuttons on the power unit housing. To raise or lower the carriage, press the appropriately marked button. When either button is released, the carriage will maintain position.

To raise the carriage, press the BLACK button on the handheld controller (or the RAISE pushbutton on the housing). Pressing a button starts the electric motor which turns the hydraulic pump. Oil from the reservoir (inside the modular power unit) flows through a suction filter and into the pump. The pump delivers pressurized oil to the hydraulic cylinder through a check valve. The check valve allows oil to flow only in one direction, i.e. to the cylinders, and prevents oil from flowing back into the pump circuit when the pump stops. This allows the carriage to maintain elevation after the control button is released.

If a load exceeds the capacity of the lifter, pressure will build up in the circuit between the pump and the cylinders when the BLACK button is pressed. This pressure forces the relief valve to unseat which in turn allows oil to circulate back to the reservoir rather than pushing it into the cylinder. This pressure relief mechanism prevents damage to the hydraulic system.

To lower the carriage, press the WHITE button (or LOWER pushbutton on the housing). This energizes the lowering solenoid valve coil, which unseats the poppet valve and allows oil to return to the reservoir from the cylinder through the pressure-compensated flow control valve. Releasing the WHITE button de-energizes the solenoid and closes the valve poppet. The poppet valve and check valve together prevent oil from returning to the reservoir and cause the cylinders to stop retracting. The carriage will maintain its position until another command is received.

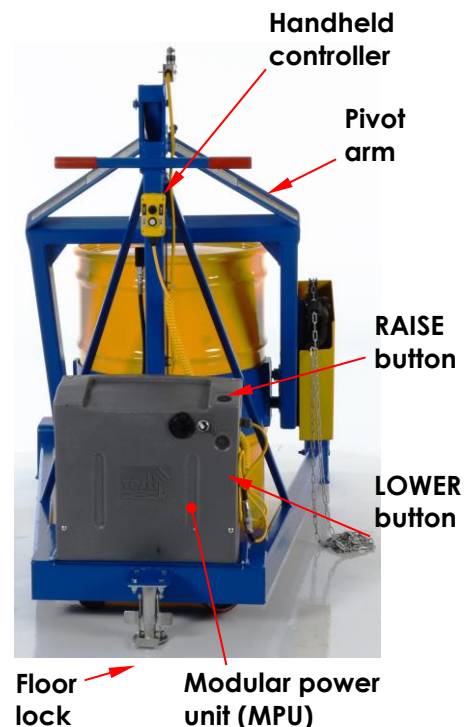

LOWERING SOLENOID VALVE

The lowering valve might occasionally need to be cleaned. See [Troubleshooting](#) on p. 22. Before working on any part of the hydraulic system, always lower the carriage.

1. Remove the cover from the power unit.
2. Identify the lowering valve (port LL in the manifold) and remove it.
3. Use a thin tool to press the poppet in (from the bottom of the valve) and open the valve.
4. Repeat several times while immersing the valve in kerosene or mineral spirits.
5. Blow compressed air through the valve while holding it open as described in step 3.
6. Inspect O-rings and the PTFE washer (polytetrafluoroethylene). If either is damaged, replace it.
7. Reinstall the valve. The valve should be tightened to approximately 20 ft.-lb. of torque.

VELOCITY FUSE

In the base of the cylinder is a brass velocity fuse with a stainless steel spring. If a fitting begins to leak or a hose is punctured, the pivot arm descends rapidly. If the rate of descent exceeds the preset activation speed of the velocity fuse, the fuse closes. While the fuse is shut oil cannot flow. The pivot arm remains stationary until pressure is reestablished.

The velocity fuse can activate although no failure occurs (e.g. air gets into the hydraulic system). To be able to raise or lower the pivot arm requires resetting the velocity fuse. To reset the fuse, activate the pump by jogging the BLACK (or RAISE) button. Immediately lower the carriage and disconnect the drum from the saddle. Cycle the pivot arm by raising it all the way up and then bringing it all the way down. Do this several times to purge air from the system.

BLEEDING AIR FROM THE HYDRAULIC CIRCUIT

If the pivot arm lowers very slowly (or not at all), air probably is trapped in the hydraulic circuit. To remove air from the hydraulic circuit, follow these directions.

1. Lower the arm and disconnect the drum from the saddle.
2. A "bleeder" screw is located at the top of the cylinder. Loosen the bleeder screw by 1/4 to 1/2 turn to allow trapped air to escape. Jog the motor to push air out of the system.
3. Only clear hydraulic fluid will flow from the bleeder screw opening when air has been completely removed. At that point, reinstall the bleeder screw.

USING THE BATTERY CHARGER (HDC-DC UNITS ONLY)

⚠WARNING Batteries contain sulfuric acid and produce explosive gases. A battery explosion could result in loss of eyesight and/or serious burns. Always have plenty of fresh water and soap nearby.

- DO NOT smoke near the battery or expose the battery to a spark or flame.
- ONLY charge batteries in dry, well-ventilated locations.
- DO NOT lay metallic items, like tools, on top of a battery.
- NEVER touch both terminals simultaneously! Remove personal jewelry items such as rings and watches.
- Operating the battery with low voltage can cause premature motor contact failure.
- The charger is equipped with an external ground wire (small green wire). During installation the charger must be grounded to the equipment. Be sure this wire is always connected to the chassis, frame, or other metallic surface considered to be ground.
- Remove accumulated deposits from the terminals. Confirm that all battery connections are sound.
- Replace defective electrical cords and wires immediately.
- DO NOT use the charger if the flanged inlet is damaged.
- DO NOT connect the charger to a damaged extension cord.

DC-powered drum carriers are equipped with an onboard battery charger with a flanged electrical inlet. The inlet projects through the cover/housing of the power unit. The user must provide a 3-prong charging cord appropriate for line and motor voltages. The charger is current limited and will not exceed its rated output even if loads are placed on the battery while it is charging. The charger fuse will blow if it is connected in reverse polarity. To charge the battery:

- 1) Plug an extension cord into the flanged inlet. Plug the other end of the cord into an 115V, 60 Hz receptacle (or receptacle that matches the unit's voltage rating). Use a short, thick extension cord to minimize voltage drop (no smaller than 18ga. or longer than 50 ft.).
- 2) The charge LED indicates the status of charge current flowing to the battery.
 - Red LED only: charger is providing full output to the battery.
 - Red and green LED's: charger is "topping off" the battery.
 - Green LED only: unit is providing a "float" (maintenance) charge.
 - DO NOT leave the charger on for long periods after the battery is fully charged.
- 3) Unplug the charger before using the unit to avoid damaging cords, receptacles, etc.

CHARGER TROUBLESHOOTING -- If the charger does not work:

- 1) Make sure all battery connections sound.
- 2) Confirm that the AC power source (e.g. wall socket) is supplying power.
- 3) Examine the fuse. See diagrams on pages 13-14 (DC-powered) or 16-17 (AC-powered). Replace only with a fuse having the same rating as the original fuse.
- 4) It will take time before current begins to flow through a highly sulfated battery.

USING THE BOOM ATTACHMENT

- 1) Prepare the load with appropriate rigging.
- 2) Attach the rigging to the load hook. The load hook must be centered above the load to prevent load swing when the boom lifts it off of the ground.

NOTE: The capacity of the unit while in crane configuration is 800 pounds (364kg). Rigging and all other equipment attached to the load must be added to the weight of the load to determine the net weight of the load. The net weight must be less than the capacity of the unit in crane configuration.
- 3) Slowly raise the load until it is suspended by the boom. Only raise the load a few inches above the ground.
 - a. The load should not swing as it rises.
 - b. The crane should not tip or rock when the load is suspended.
 - c. If the crane is unstable when the load is suspended, return the load to the ground and disconnect it from the hook. Do not use the crane to transport the load.
- 4) Transport the load by carefully/slowly pushing the crane. Only traverse even, level ground. Do not leave the crane while a load is suspended.

⚠WARNING Improper use might result in serious personal injuries.

- ONLY use the unit on even, level, improved surfaces capable of supporting the combined weight of the crane and a full capacity load.
- Stand clear of the load while raising and lowering it! ALWAYS watch the boom while raising and lowering a load. It should rise smoothly. Watch for binding or jerky movement and listen for unusual noises.
- Before leaving the crane unattended, unload it and relieve hydraulic pressure by turning the release lever counterclockwise until the boom begins to descend. Lower the boom completely; then close the release valve.
- Always tighten the shackle pin *before each use*. See [BOOM ATTACHMENT](#) on p. 3.

LIFTING DRUMS (STANDARD AND POWERED UNITS)

Only use this drum carrier on level, even, improved surfaces, i.e. concrete or asphalt, capable of supporting the combined weight of the unit and a full capacity load. Full capacity load = 800 pounds for all units; also refer to [SPECIFICATIONS](#) document, p. 3; refer to label 1153 in [LABELING DIAGRAM](#), p. 23. For all models, capacity is reduced to 500 pounds whenever a drum is half-full or less.

1. Move the unit into position around the drum. Open the hinged saddle doors so the drum can fit inside the saddle. Use the gear handle (HDC-305-60) or gear chain (all of models) to adjust the rotation of the saddle. The saddle should be in the horizontal position.

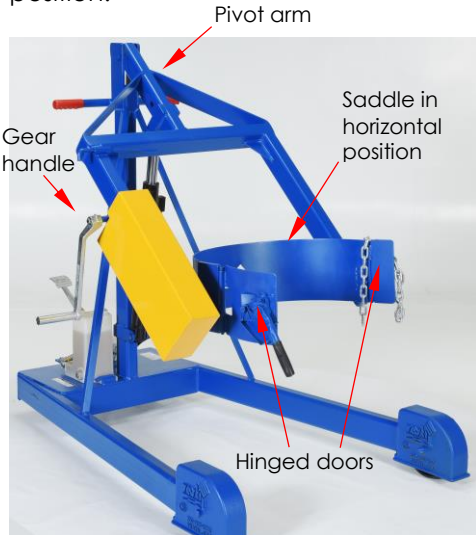

2. Adjust the elevation of the pivot arm to bring the top of the drum saddle into contact with the drum just below the middle rim of the drum. Close the hinged doors against the side of the drum.

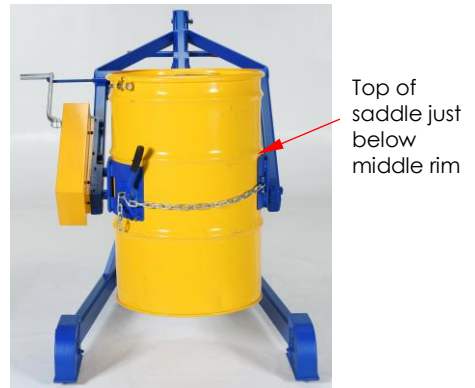

3. Wrap the chain around the drum. Feed the chain through the chain clamp. Press down on the clamp handle to firmly pinch the chain between the bottom of the clamp handle and the clamp stud. There should be no slack in the chain when the clamp is properly applied. To release the clamp, see instruction 6 (below).

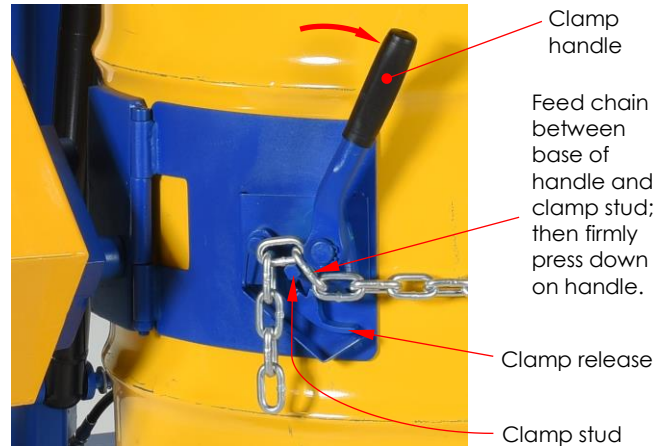

4. Lift the drum just a few inches above the ground using either the foot pump (standard units) or modular power unit (HDC-DC and HDC-AC options):

- Instructions for operating the foot pump appear on pages 8-11.
- Instructions for operating the MPU are given on pages 15-17.

5. Apply the floor lock and elevate the drum as the application requires. Rotate the drum using either the gear handle or gear chain:

- HDC-305-60: turning a handle on the gear box rotates the saddle. Turn the handle clockwise to rotate the drum forwards. Turn it counter-clockwise to tip the drum backwards.
- All other models use a chain drive to rotate the saddle. Pull down the right side of the chain to rotate the saddle and drum forwards. Pulling on the left side of the chain rotates the saddle and drum backwards.

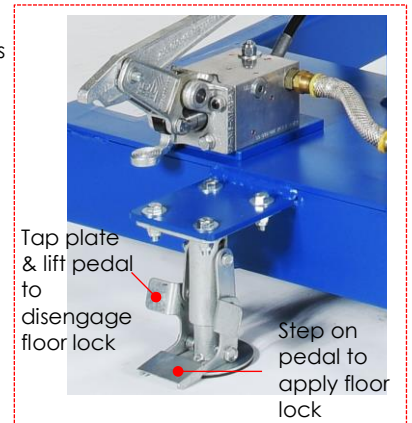

6. Rotate the drum to the upright position and return it to the ground (press the release lever or the white button on the handheld controller). Once the drum rests on the ground, press down on the clamp release (refer to step 3) and rotate the handle counterclockwise to release the chain.

INSPECTIONS & MAINTENANCE

Regular maintenance is required to keep this product in satisfactory condition.

- o Relieve hydraulic pressure whenever the unit is not in use by fully lowering the pivot arm.
- o Keep the product clean & dry. Lubricate moving parts at least once per month.
- o If repairs are necessary, only install manufacturer-approved replacement parts. Vestil is not responsible for issues or malfunctions that result from the use of unapproved replacement parts.
- o ONLY use ISO AW-32 hydraulic fluid or its equal in the hydraulic system. Do not use brake fluid or jack oils in the hydraulic system. If oil is needed, use an anti-wear hydraulic oil with a viscosity grade of 150 SUS at 100°F, (ISO 32 cSt @ 40°C), or Dexron transmission fluid.

RECORD OF SATISFACTORY CONDITION - Before using the unit for the first time, make a written record of its appearance. Include observations about each component. Include details about the appearance and function of the saddle, chain clamp, and gear train mechanisms. How much effort is required to turn the saddle handle (HDC-305-60) or to pull the gear chain (all other models)? Raise and lower the pivot arm. Include observations about how the unit sounds as the arm rises and descends. Make note of how much effort is required to move the pump pedal (standard models) or how quickly the unit responds to pushbutton signals (electric powered models). Install the [boom attachment](#) (see p. 3) and apply a full capacity load. Record observations about how the frame and boom respond to the load. Photograph the unit from multiple perspectives. Include close range photos of all features listed in subparts (A) and (B) (below). Collect all writings and photos in a file. This file is a record of the unit in satisfactory condition. Compare all inspection results to the record to determine if the unit is in satisfactory condition. DO NOT use the unit unless it is in satisfactory condition.

(A) Before Each Use--Inspect the following:

1. Wiring: inspect the electrical wiring for cuts and frays.
2. Casters: examine the casters. Casters should be solidly fastened to the frame. Look for areas of severe wear and damage. Each caster should roll smoothly and without wobbling.
3. Hydraulic hoses: check for pinches, punctures, and loose connections.
4. Frame elements: inspect the legs, vertical members, and braces for cracked welds, bends, etc.
5. Saddle and pivot arm: visually examine the saddle and arm for damage.
6. Pushbutton controller and modular power unit (MPU): inspect the controller and look for damage that exposes internal components. Make sure that the cover of the MPU is not punctured or in other ways noticeably damaged.

(B) Monthly Inspections--at least once per month check the following:

1. Oil level: oil should be 1" to 1-1/2" below the top of the tank with the arm in the lowered position. Add oil as necessary. Look for oil leaks, e.g. from hoses, the cylinder, or the reservoir.
2. MPU, hand control, and battery (electric powered models only): Remove the cover of the MPU and visually inspect the components. Check the water level in the battery. Check for worn or damaged hydraulic hoses, electrical wires, and cords. Repair as necessary.
3. Clevis pins and pivot points: inspect for excessive wear.
4. Cylinder, foot pump or modular power unit: confirm that the cylinder extends and retracts smoothly. The cylinder should not be bent, cracked, etc. No more than normal effort should be required to work the foot pump.
5. Chains: inspect chain links for elongations, breaks, etc.
6. Saddle and pivot arm: observe the arm as it cycles up and down. Make note of unusual noise and motion (e.g. binding). Rotate the saddle in both directions. Watch and listen for unusual behaviors.
7. Labels: confirm labels are in place, undamaged, & easily readable. See [LABELING DIAGRAM](#), p. 23.
8. (Boom attachment) Boom, load hook, & shackle: Closely examine the boom, particularly the mounting bracket, load hook & shackle. Refer to [BOOM ATTACHMENT](#) on p. 3. Confirm that the safety latch (of the hook) operates correctly. The mounting bracket must be square, rigid, and free of cracks and significant bends. Pin holes (in mounting bracket & pivot arm) should not be elongated.
9. Surfaces: wash the unit to remove dirt and debris.

(C) Yearly Inspection

Hydraulic oil should be changed at least once a year or sooner if the oil darkens or becomes gritty. Oil should also be changed if it has a milky appearance, which indicates that water is present. If oil is needed, use HO150 hydraulic fluid. Any anti-wear hydraulic fluid with a viscosity grade of 150 SUS at 100° F (ISO 32 @ 40° C) such as AW32 or Dexron transmission fluid is acceptable. Flush the reservoir with new oil before refilling it.

TROUBLESHOOTING (HDC-DC & HDC-AC)

Contact [TECHNICAL SERVICE](#) to resolve issues not addressed in this guide. Also refer to the [MPU-AC-GEN2](#) or [MPU-DC-GEN2](#) manual.

Issue	Possible Cause	Remedy
1. Pivot arm does not rise and motor does not run.	a. [HDC-DC] Low battery voltage. (Check light) b. [HDC-AC] All chassis connections to negative post of battery not made well.	a. Recharge battery b. Check and tighten or clean connections if necessary.
2. Pivot arm does not rise but motor is running or humming.	c. Voltage at motor terminals might be too low to run pump at existing load. d. Fluid level in reservoir is low. e. Load exceeds capacity requirements. Relief valve is allowing hydraulic fluid to flow back into the reservoir. f. Suction filter is clogged, starving pump. g. Suction line fittings are loose allowing air to enter. h. Filter/Breather cap on tank is clogged. i. Lowering solenoid valve might be energized by faulty wiring or might be stuck open. j. Hydraulic pump not operating.	c. Measure voltage at motor terminals (as near as possible) while pump runs under load. Check for loose wiring connections. d. Add fluid. See " Monthly inspections " and " Yearly inspection " on p. 21 for proper fluid level. e. DO NOT CHANGE RELIEF VALVE SETTING. Instead, reduce the load to rated capacity. f. Remove filter and clean. g. Inspect all fittings for proper tightness. h. Remove cap and clean. i. Remove lowering solenoid valve. Check and clean. (Refer to "Lowering Solenoid Valve" on p. 18 .) j. Disconnect hydraulic line from power unit. Put pressure line in a large container and operate the pump. If no output, check the pump motor coupling and correct as appropriate. If pump is worn, contact factory for replacement parts.
3. Pivot arm rises too slowly.	k. Foreign material stuck in lowering solenoid valve causing fluid to flow back into the reservoir. l. Foreign material clogging suction filter or breather cap, or a hose is pinched. m. Low motor voltage. n. Unit overloaded. o. Inoperative pump.	k. Lower the carriage. Remove the lowering solenoid valve and clean. Refer to p. 18 . l. Correct as appropriate. See also, 2(f), (h). m. See 1 (b). n. See 2 (e). o. See 2 (j).
4. Motor labors or is extremely hot.	p. [HDC-DC] Battery voltage too low. q. Oil starvation causing pump to bind & overheat. [NOTE: If this occurs, pump can be permanently damaged.] r. Binding cylinder.	p. See 1 (b) q. See 2 (d), (f), (g), (h), (j) r. Align cylinder correctly.
5. Pivot arm rises in jerks or is spongy when elevated.	s. Fluid starvation. t. Air in system.	s. See 2 (d), (f), (g), (j) t. See " Bleeding air from the hydraulic circuit " on p. 18 .
6. Pivot arm lowers too slowly when loaded.	u. Lowering solenoid valve filter screen clogged. v. Pinched tube or hose. w. Foreign material in flow control valve. x. Binding cylinders. y. Foreign material in velocity fuse.	u. Remove lowering solenoid valve and clean filter screen. v. Correct as appropriate. w. Remove and clean flow control valve. Refer to Hydraulic Circuit Diagram on p. 17 . x. Align cylinders correctly. y. Remove and clean velocity fuse. Refer to Hydraulic Circuit Diagram on p. 17 .
7. Pivot arm lowers too quickly.	z. Foreign material stuck in flow control valve. (In this case, carriage initially lowers at a normal rate but accelerates as the carriage descends).	z. Remove flow control valve from the valve block and clean. Refer to Hydraulic Circuit Diagram on p. 17 .
8. Pivot arm rises then slowly lowers on its own.	aa. Lowering solenoid valve may be incorrectly wired or is stuck open bb. Check valve stuck open. cc. Leaking hoses, fittings, pipes. dd. Cylinder packing is worn or damaged.	aa. See 3 (k). bb. Remove and clean check valve. cc. See 2 (c). dd. Replace packing (contact factory for replacement parts).
9. Pivot arm elevates but does not lower.	ee. Incorrect lowering solenoid valve wiring. ff. Lowering solenoid valve is stuck. gg. Faulty lowering solenoid coil. hh. Binding cylinders. ii. Air present in the hydraulic system causing the velocity fuse to activate	ee. Correct per diagram (p. 13 (DC) or 16 (AC)). ff. Lightly tap down the solenoid coil body to seat it properly. DO NOT hit coil hard as it will permanently damage the internal system. DO NOT remove the solenoid valve from the block because the carriage will descend dangerously quickly. gg. Remove and replace. DO NOT remove the lowering solenoid valve from the block because the carriage will lower in an uncontrolled manner. hh. See 4 (r). ii. To unlock, pressurize the hydraulic system.

LABELING DIAGRAM

Each unit should be labeled as shown in the diagram. However, label content and location are subject to change so your product might not be labeled exactly as shown. Compare this diagram to your [Record of Satisfactory Condition](#). If there are differences between actual labeling and this diagram, adapt the diagram to reflect actual labeling. Replace all labels that are damaged, missing, or not easily readable (e.g. faded). To order replacement labels or to inquire whether your unit is properly labeled, contact the [technical service and parts department](#) online at http://www.vestilmfg.com/parts_info.htm or by calling (260) 665-7586 and asking for the [Parts Department](#).

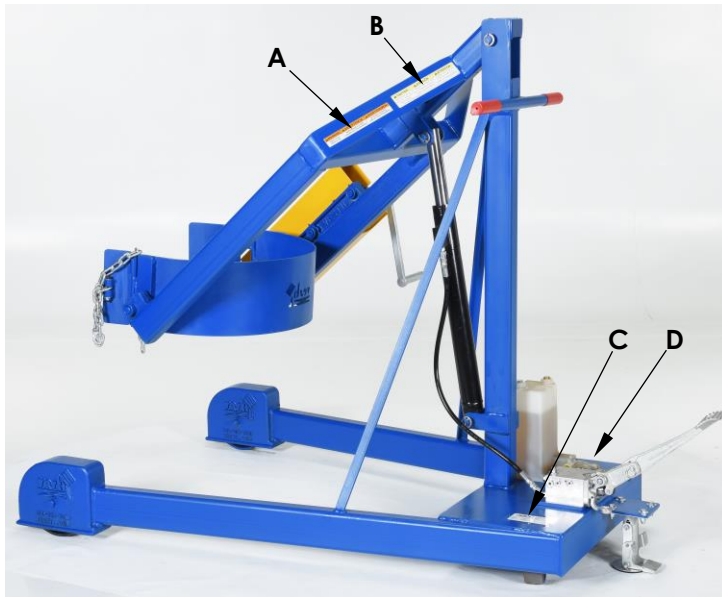

A: Label 220 (applied to side of pivot arm)

▲ WARNING	▲ ADVERTENCIA	▲ AVERTISSEMENT
KEEP CLEAR WHEN IN USE	MANTENGASE ALEJADO CUANDO SE ESTA OPERANDO	SE TENIR À DISTANCE LORS DU FONCTIONNEMENT

B: Label 232 (applied to side of pivot arm)

▲ CAUTION	▲ ATENCIÓN	▲ ATTENTION
DRUM MUST BE IN VERTICAL POSITION WHEN MOVING	EL TAMBOR DEBE DE ESTAR EN LA POSICIÓN VERTICAL CUANDO EN MOVIMIENTO	LE BIDON DOIT ÊTRE EN POSITION VERTICALE LORS D'UN DÉPLACEMENT

VESTIL MANUFACTURING CORPORATION • Phone (260) 665-7586 • Fax (260) 665-1339 • sales@vestil.com • www.vestil.com

C: Label 1153 (applied to frame by foot pump)

MODEL / MODÉLO / MODÈLE _____
WEIGHT / PESO / MASS _____
CAPACITY / CAPACIDAD / CAPACITÉ _____
SERIAL / SERIE / SÉRIE _____
UNITS: 2.2 lb. = 1kg 1" (or 1in.) = 2.54cm 1153

D: Label 206 (on base frame by oil reservoir or inside MPU on oil tank)

ISO 32 / 150 SUS	
HYDRAULIC OIL OR NON-SYNTHETIC TRANSMISSION FLUID	
ACEITE HIDRAULICO O LIQUIDOS DE TRANSMISION NO SINTETICOS	
HUILE OU LIQUIDE HYDRAULIQUE NON-SYNTHÉTIQUE	206 Rev. 1003
VESTIL MANUFACTURING CORPORATION • Phone (260) 665-7586 • www.vestil.com	

Electric powered units also have the following labels applied to the modular power unit:

HDC-DC

D: label 206 applied inside MPU cover

ISO 32 / 150 SUS	
HYDRAULIC OIL OR NON-SYNTHETIC TRANSMISSION FLUID	
ACEITE HIDRAULICO O LIQUIDOS DE TRANSMISION NO SINTETICOS	
HUILE OU LIQUIDE HYDRAULIQUE NON-SYNTHÉTIQUE	206 Rev. 1003
VESTIL MANUFACTURING CORPORATION • Phone (260) 665-7586 • www.vestil.com	

Label 295 (on MPU cover)

▲ WARNING	
Enclosed battery contains hazardous chemicals.	
DO NOT handle enclosed battery UNLESS wearing eye protection and other appropriate personal protective equipment.	
DO NOT directly contact skin with battery.	
DO NOT expose to sparks or extreme heat; battery contains explosive gases.	
▲ ADVERTENCIA	
La batería incluida contiene materiales peligrosos.	
NO use la batería incluida A NO SER que lleve protección de ojos y otros equipos de protección apropiados para el personal.	
NO tenga contacto directo en la piel con la batería.	
NO exponga a destellos o a calor excesivo, la batería contiene gases explosivos.	
295 rev 0111	

HDC-AC

D: label 206 is applied to metal frame inside MPU cover

ISO 32 / 150 SUS	
HYDRAULIC OIL OR NON-SYNTHETIC TRANSMISSION FLUID	
ACEITE HIDRAULICO O LIQUIDOS DE TRANSMISION NO SINTETICOS	
HUILE OU LIQUIDE HYDRAULIQUE NON-SYNTHÉTIQUE	206 Rev. 1003
VESTIL MANUFACTURING CORPORATION • Phone (260) 665-7586 • www.vestil.com	

Label 248; 249; 250; or 251 electrical system specifications

NOTICE	NOTA	AVIS
POWER SUPPLY: V/ Phase/ HZ		
CONTROL VOLTAGE: V AC		
CORRIENTE: V/ Fase/ HZ		
VOLTAJE DE CONTROL: V CA		
ALIMENTATION ÉLECTRIQUE: V/ Monophase/ HZ		
VOLTAGE DE CONTRÔLE: V AC		



LIMITED WARRANTY

Vestil Manufacturing Company ("Vestil") warrants this product to be free of defects in material and workmanship during the warranty period. Our warranty obligation is to provide a replacement for a defective, original part covered by the warranty after we receive a proper request from the Warrantee (you) for warranty service.

Who may request service?

Only a warrantee may request service. You are a warrantee if you purchased the product from Vestil or from an authorized distributor AND Vestil has been fully paid.

Definition of "original part"?

An original part is a part used to make the product as shipped to the Warrantee.

What is a "proper request"?

A request for warranty service is proper if Vestil receives: 1) a photocopy of the Customer Invoice that displays the shipping date; AND 2) a written request for warranty service including your name and phone number. Send requests by one of the following methods:

<u>US Mail</u>	<u>Fax</u>	<u>Email</u>
Vestil Manufacturing Company 2999 North Wayne Street, PO Box 507 Angola, IN 46703	(260) 665-1339 <u>Phone</u> (260) 665-7586	info@vestil.com Enter "Warranty service request" in the subject field.

In the written request, list the parts believed to be defective and include the address where replacements should be delivered. After Vestil receives your request for warranty service, an authorized representative will contact you to determine whether your claim is covered by the warranty. Before providing warranty service, Vestil will require you to send the entire product, or just the defective part (or parts), to its facility in Angola, IN.

What is covered under the warranty?

The warranty covers defects in the following original, dynamic parts: motors, hydraulic pumps, motor controllers, and cylinders. It also covers defects in original parts that wear under normal usage conditions ("wearing parts"), such as bearings, hoses, wheels, seals, brushes, and batteries.

How long is the warranty period?

The warranty period for original dynamic components is 90 days. For wearing parts, the warranty period is 90 days. Both warranty periods begin on the date Vestil ships the product to the Warrantee. If the product was purchased from an authorized distributor, the periods begin when the distributor ships the product. Vestil may, at its sole discretion, extend a warranty period for products shipped from authorized distributors by up to 30 days to account for shipping time.

If a defective part is covered by the warranty, what will Vestil do to correct the problem?

Vestil will provide an appropriate replacement for any covered part. An authorized representative of Vestil will contact you to discuss your claim.

What is not covered by the warranty?

The Warrantee (you) is responsible for paying labor costs and freight costs to return the product to Vestil for warranty service.

Events that automatically void this Limited Warranty.

- Misuse;
- Negligent assembly, installation, operation or repair;
- Installation/use in corrosive environments;
- Inadequate or improper maintenance;
- Damage sustained during shipping;
- Collisions or other accidents that damage the product;
- Unauthorized modifications: Do not modify the product IN ANY WAY without first receiving written authorization from Vestil.

Do any other warranties apply to the product?

Vestil Manufacturing Co. makes no other express warranties. All implied warranties are disclaimed to the extent allowed by law. Any implied warranty not disclaimed is limited in scope to the terms of this Limited Warranty. Vestil makes no warranty or representation that this product complies with any state or local design, performance, or safety code or standard. Noncompliance with any such code or standard is not a defect in material or workmanship.