

Assembly Instructions

Caution: You must read this before you proceed.

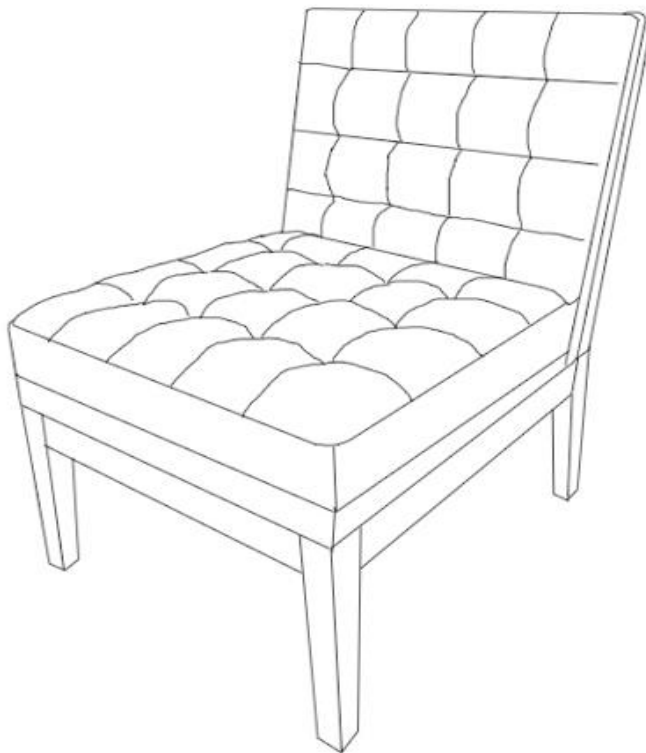

Please look in the bottom of Chair Seat for hardware packs.

ACCENT CHAIR





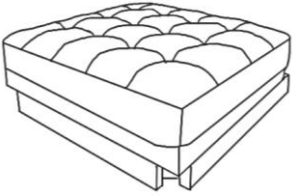

Parts List

Label	Picture	Description	Qty
A	A line drawing of the chair backrest. It shows the tufted pattern and the attachment points at the bottom where it would connect to the seat. The backrest is shown from a slightly angled perspective.	Chair Back	1

B		Chair Seat	1
C		Wooden Leg	2

Hardware

Label	Picture	Description	Qty
①		Bolt(M8X50mm)	6
②		Bolt(M8X60mm)	5
③		Washer	11
④		Spring Washer	11
⑤		Allen Wrench	1

Assembly Preparation

Before Beginning Assembly:

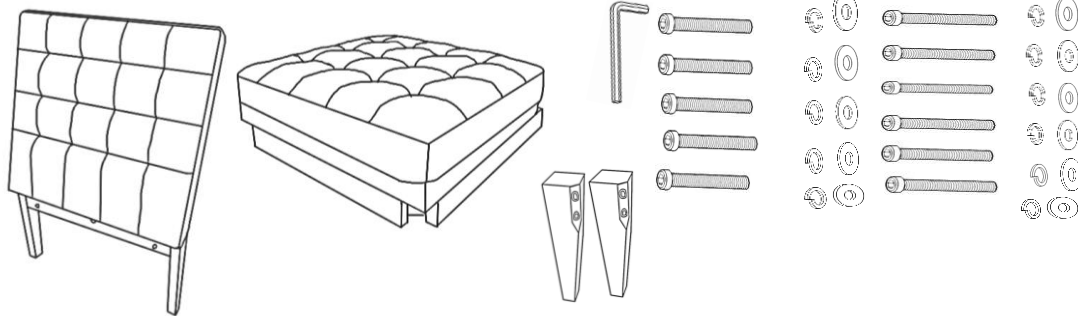

- Read instructions, cover to cover-



- Have 2 adults on hand for assembly-



- Do not assemble on flooring or carpet-



- Assemble on a clean non-marring surface (packing foam)-



- Save all packaging until finished-

Assembly Steps

Overview

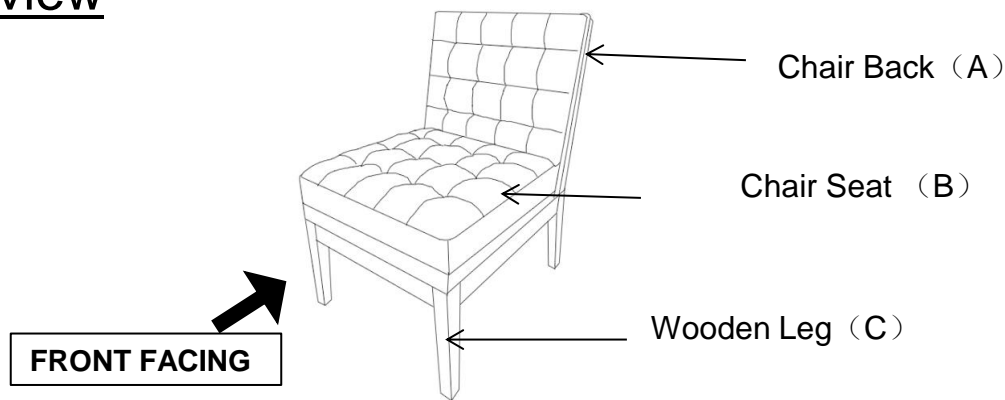

This Chair has multiple parts and may require up to 30 minutes to assemble. To give you an overview of the Chair parts, the above picture is to help you put the various parts into perspective. Please read through the instructions below to familiarise yourself with the parts and steps before assembly.

Step 1

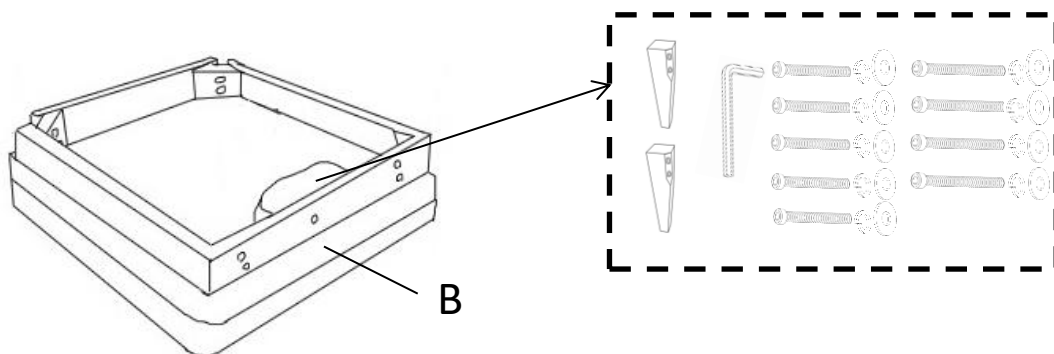

Place the Chair Seat(B) Face down on a soft surface to avoid any scratches or damage to the product.

Take out the legs and hardware from the Bottom of the Chair Seat (B).

Step 2

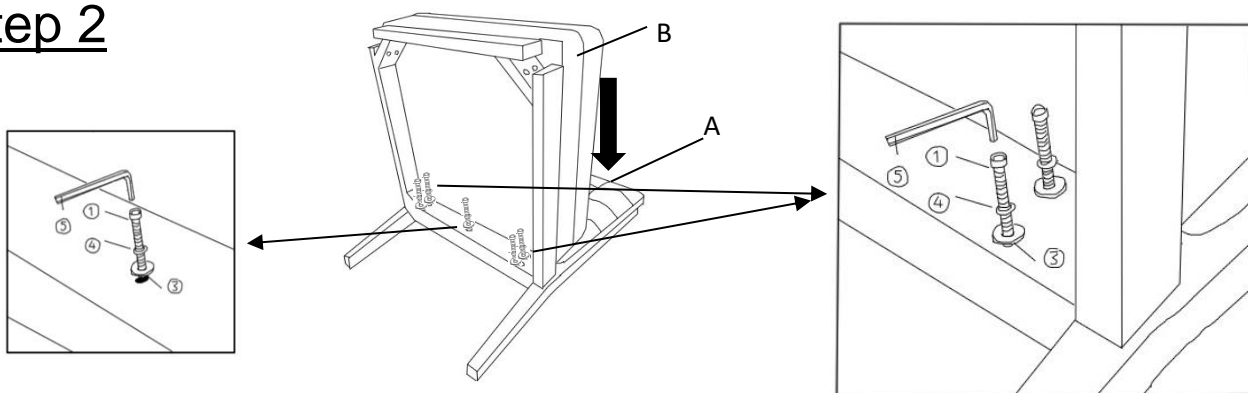

Put the Chair Back(A) onto a flat, clean, non-marring table.

With the assistance from a second adult, align the mounting positions of the Chair Back(A) and Chair Seat (B). Use your left hand to push the seat floorwards, depicted by the Arrow .

This action helps to ensure the Chair Seat(B) is pressed towards to the Chair Back(A) with no gap between them.

Using Bolts(①), Spring Washers(④) and Washers(③) with the Allen Wrench(⑤) as shown above.

Do not fully tighten Bolts.

Step 3

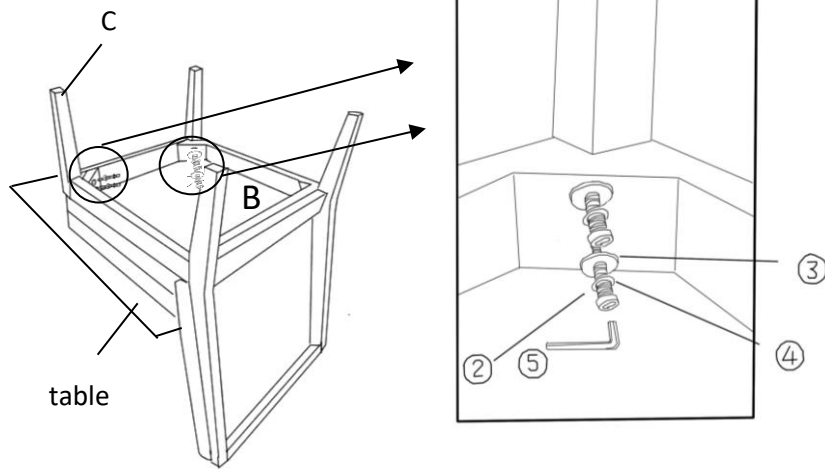

Place the chair onto the side of a table as seen in the picture .
Position Wooden Leg(C) into the Chair Seat(B) and attach using Bolts(②), Spring Washers(④) and Washers(③) with the Allen Wrench(⑤).
Repeat this same step to attach the other Leg (C) to the Chair Seat(B).
Do not fully tighten Bolts.

Step 4

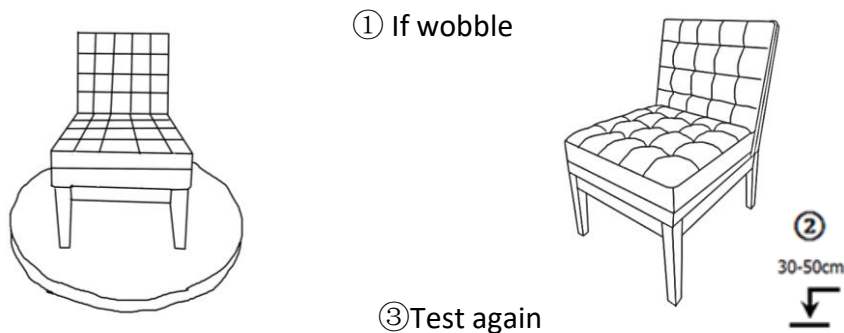

Place the Accent Chair on a Level Surface to see if it wobbles.
If it wobbles, lift the accent chair some 30cm to 50cm high from the ground.
Keep your feet and toes well away from the drop zone.
Drop the Chair freely and vertically with all four legs hitting the ground at the same time.
This Drop Test will help to ensure that all Bolts, and gaps reach full alignment status.
Test again for evenness on a Level Surface.
If no wobbles are found, proceed to tighten all the Bolts.
Note: When tightening the Bolts, tighten sequentially. Do not tighten any Bolt fully and then move towards the next one. This could cause the frame to warp.
If there are still wobbles, loosen the Bolts and execute this same drop test.
Note: If the accent chair is not stable, it could lead to damage of the product.

Step 5



Stand the chair right side up.
Inspect and make sure all parts are connected, locked and fully secured into position.
The chair is ready to be used.
This Accent Chair can only be used on a flat, level surface.

Care & Maintenance



- Furniture may scratch floors. We recommend using furniture pads to protect your floors.



- Do not put hot items directly on furniture surface.



- Do not clean furniture with harsh cleansers or polish.



- Do not place furniture under direct sunlight.



- Do not place furniture near heating or cooling vents.



- Do not write on furniture without a padded barrier to protect the surface.



- Do not place furniture outside . For indoor use only.



- Not for commercial use. For residential use only.



- Stains may be removed with mild soap solution and damp cloth.



- Children should not climb or jump on the furniture.



- Dust and pick-up spills using a clean, non-colored, lint-free cloth.