

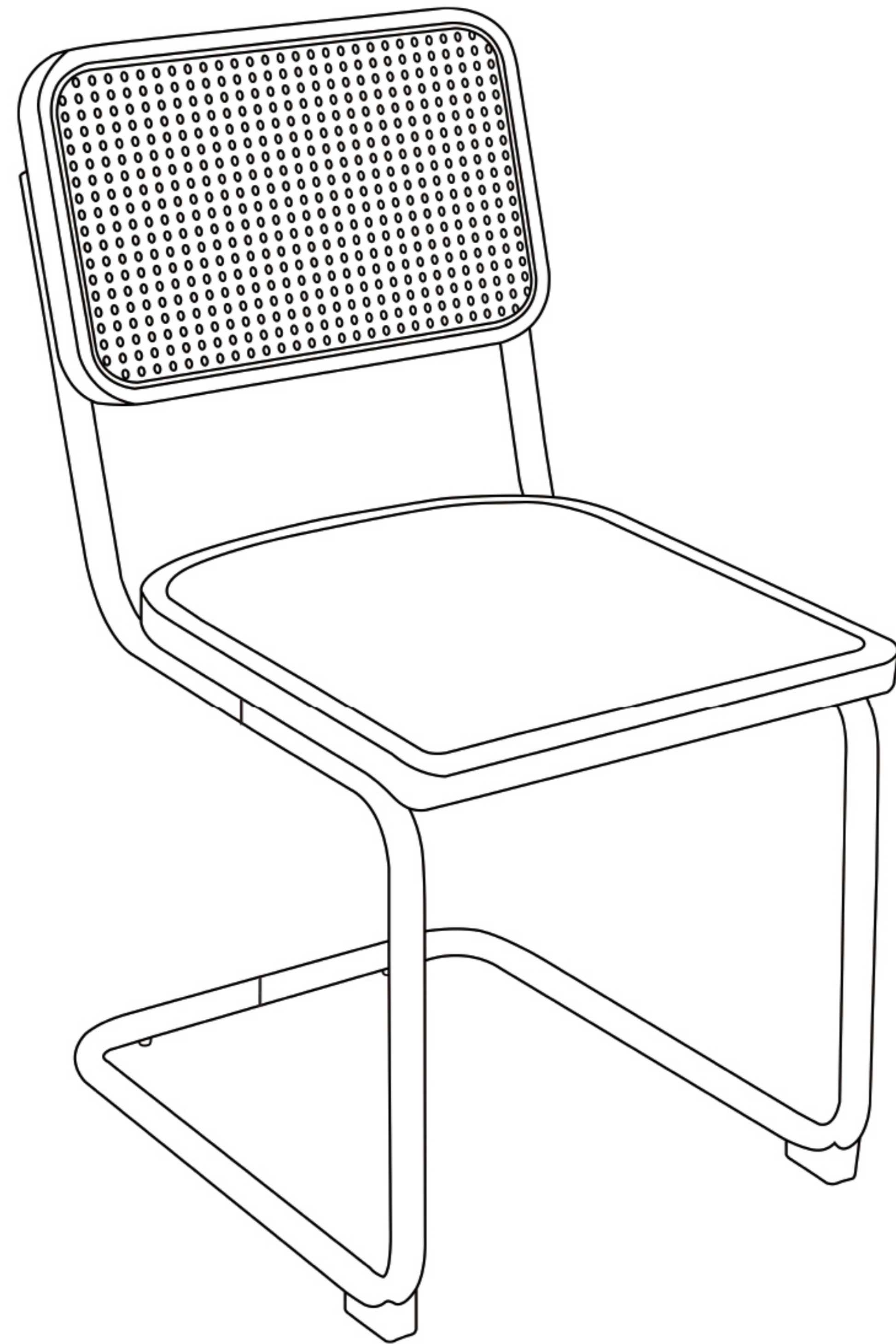

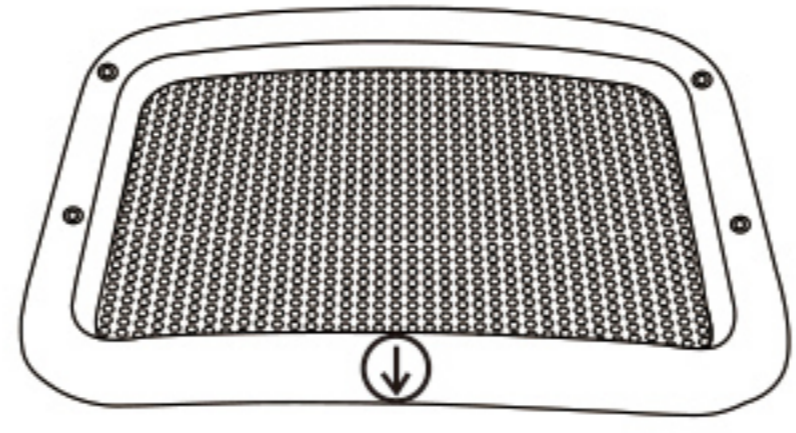

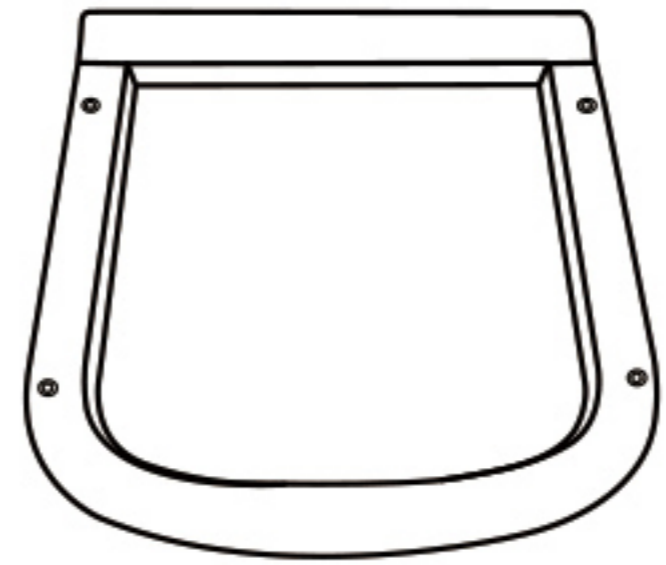



INSTRUCTION MANUAL

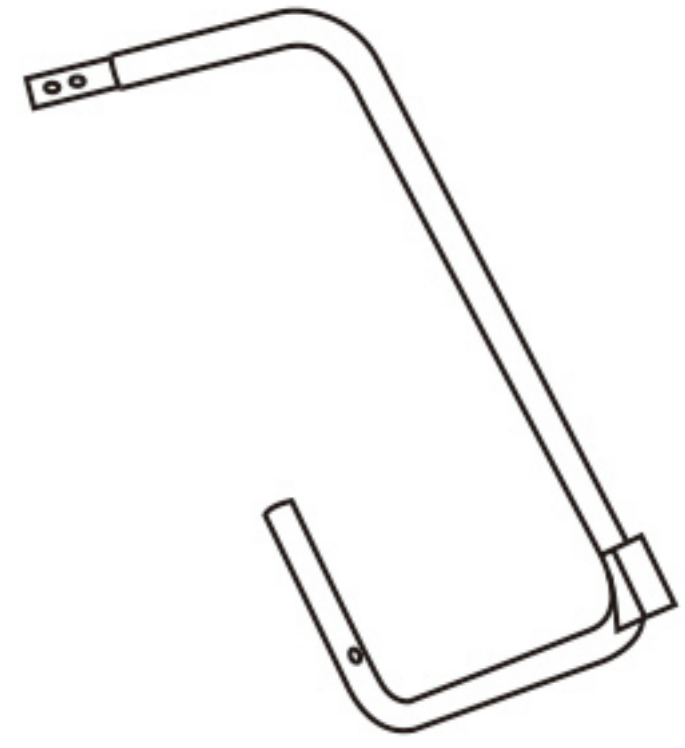

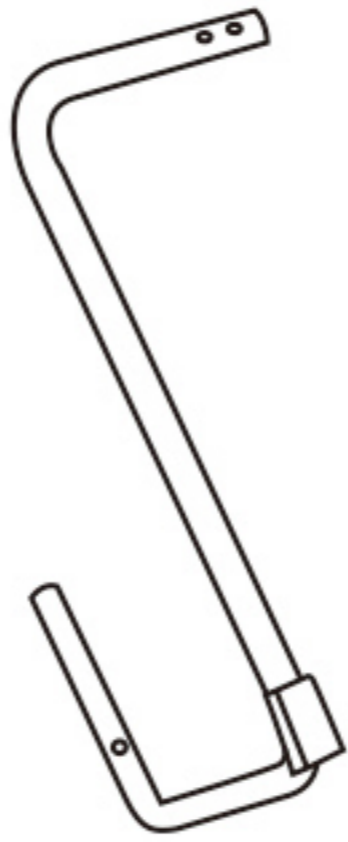
- Make sure you have all the parts listed in the instruction.
- Assemble step by step and follow the instructions.
- Assemble on a soft mat to avoid any scratches.
- Do not use power tools on the assembly.
- Periodically check and tighten screws where necessary.

A	X1	B	X1	C	X2	D	X1
							

E	X1	F	X3	G	X9	H	X1	
			M6X14		M6X35		M6	

Please check that all parts are in good condition before assembling
If any aren't, hold off assembling the product and contact us straight away so we can resolve this for you.

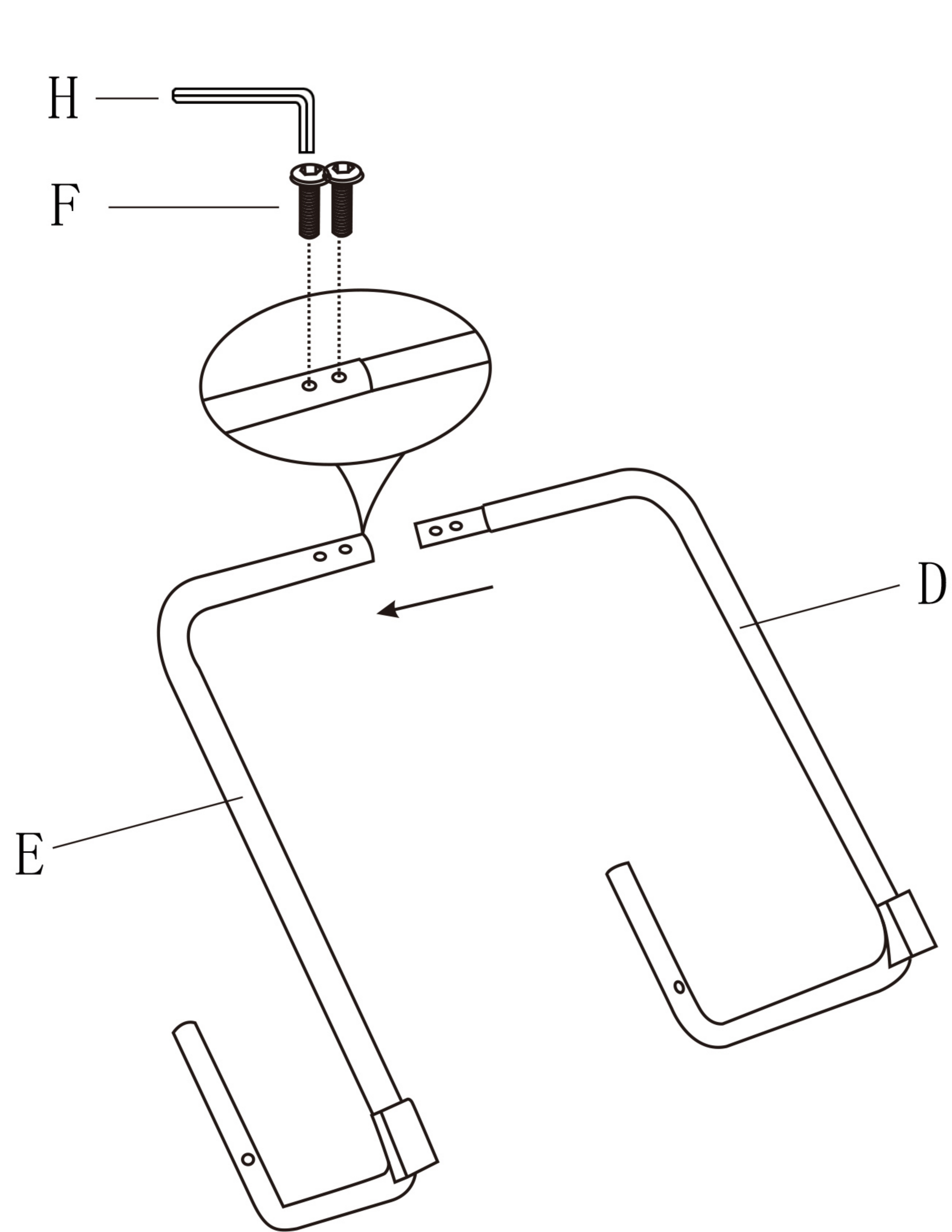

Insert D into E firstly, then insert two
Scews (F) by Wrench (H).

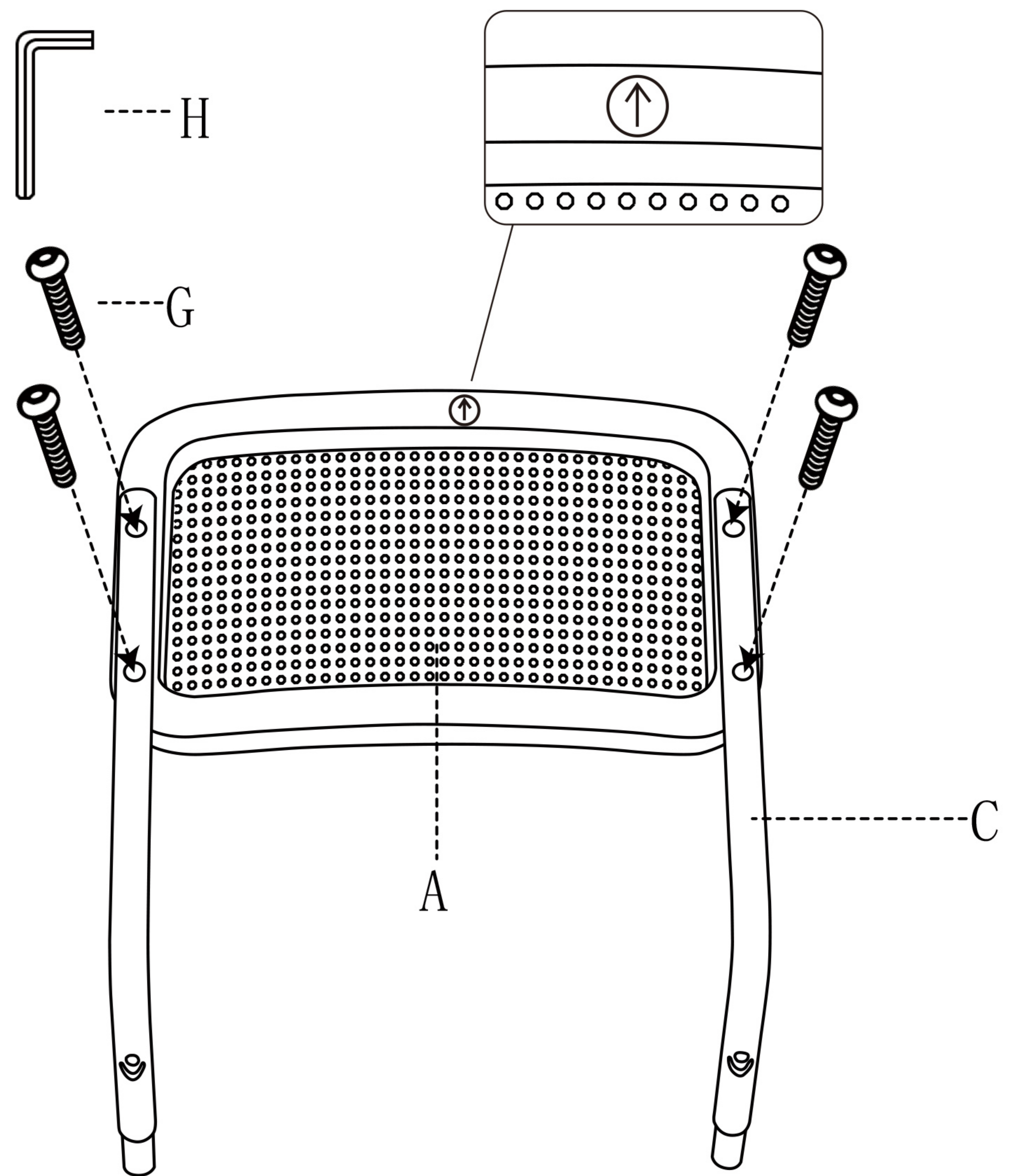

Insert Screws (G) by Wrench (H) with Part A and Part C,
do not fully tighten at this stage.

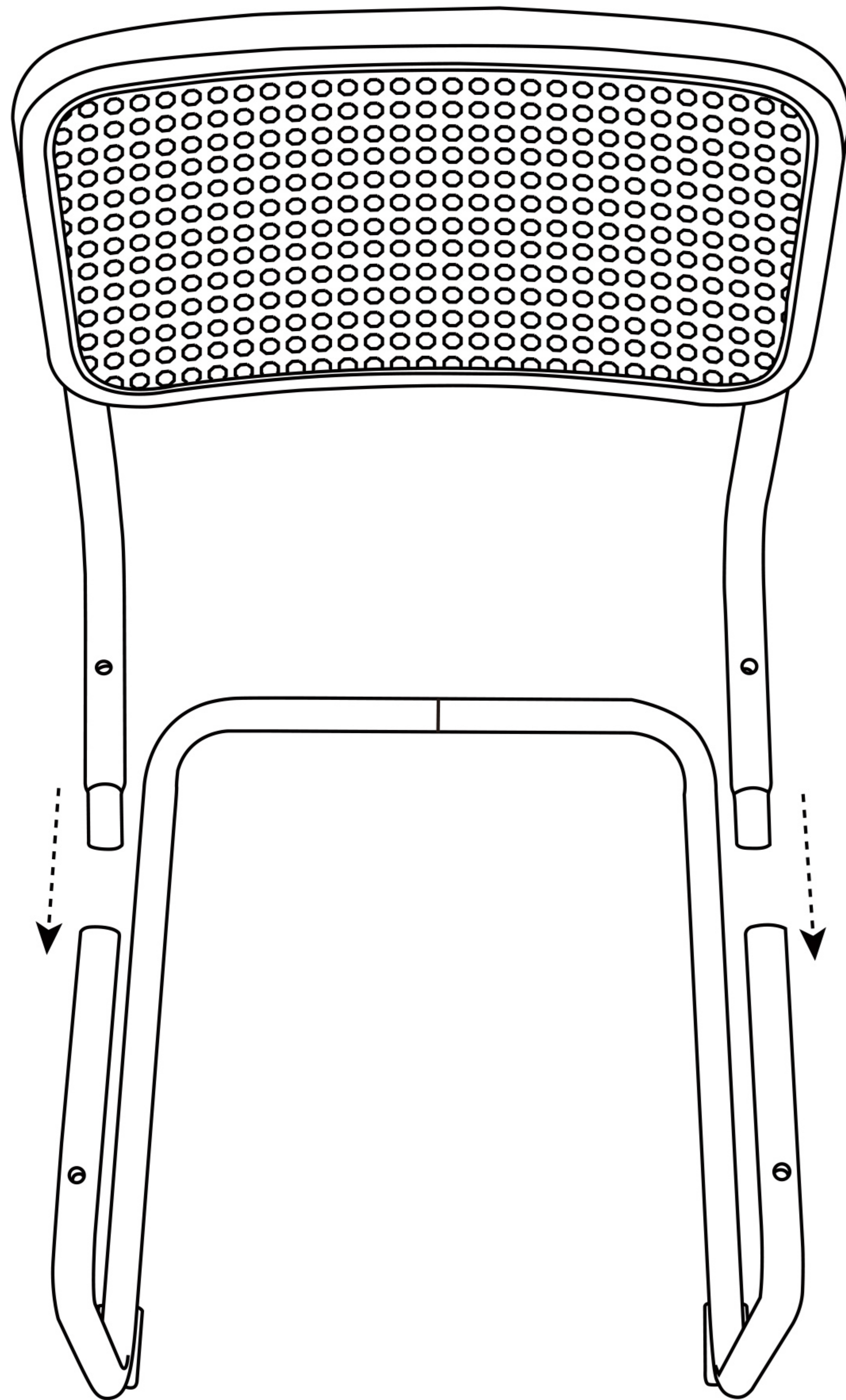

Insert Part C into Part D,E.

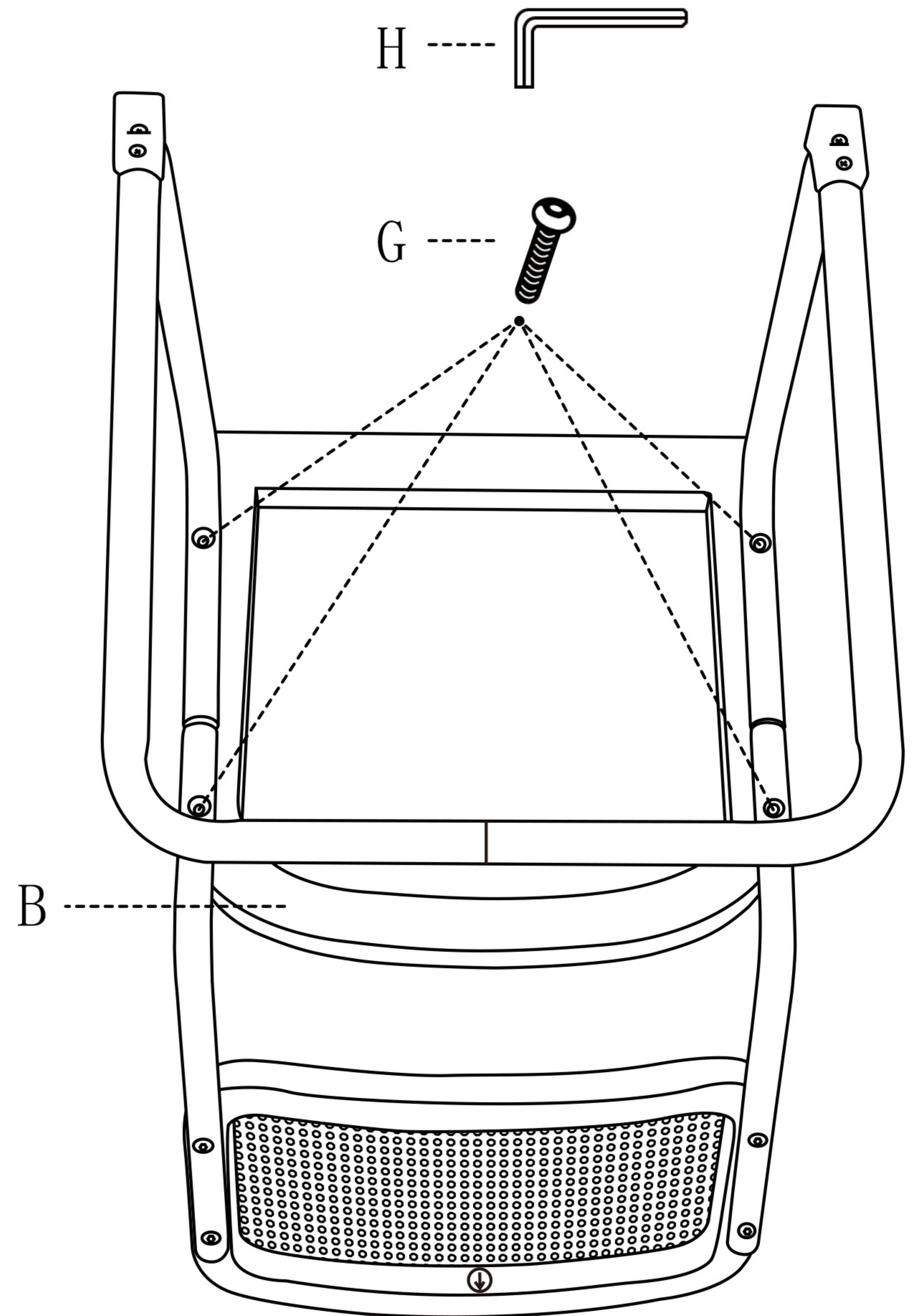

Insert Screws (G) by Wrench (H) for Part B, and tighten screws to 100%.

