

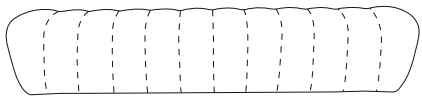
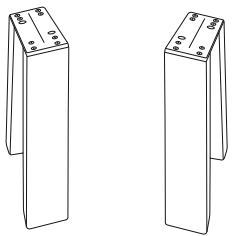
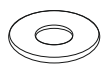
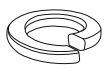
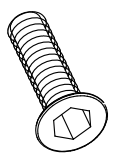

ASSEMBLY INSTRUCTIONS

Item #53001966

PART LIST

<h1>A</h1>	SEAT X1					<p>Before beginning</p> <p>1) Carefully unpack and position the item on a clean, non-marring surface to assemble.</p> <p>2) Read this Assembly Instructions from beginning to end before starting to assemble.</p> <p>3) Take an inventory of the required parts to ensure all are available.</p> <p>4) To prevent accidental choking hazards, keep all packing materials away from small children.</p> <p>5) Only tighten hardware until ALL hardware are fully engaged on their locations. Overtighten bolts will damage the bolt threads.</p> <p>6) Use only factory provided hardware to assemble. Unapproved hardware can damage product or jeopardize the structural integrity of the product.</p> <p>7) The use of power tool to assemble is not recommended due to high risk of over-torque, which can damage the product.</p>
<h1>B</h1>	LEGS X2					
<h1>Z</h1>	HARDWARE	Z1  8 mm X4	Z2  8 mm X4	Z3  8x47 mm X4	Z4  5x80 mm X1	

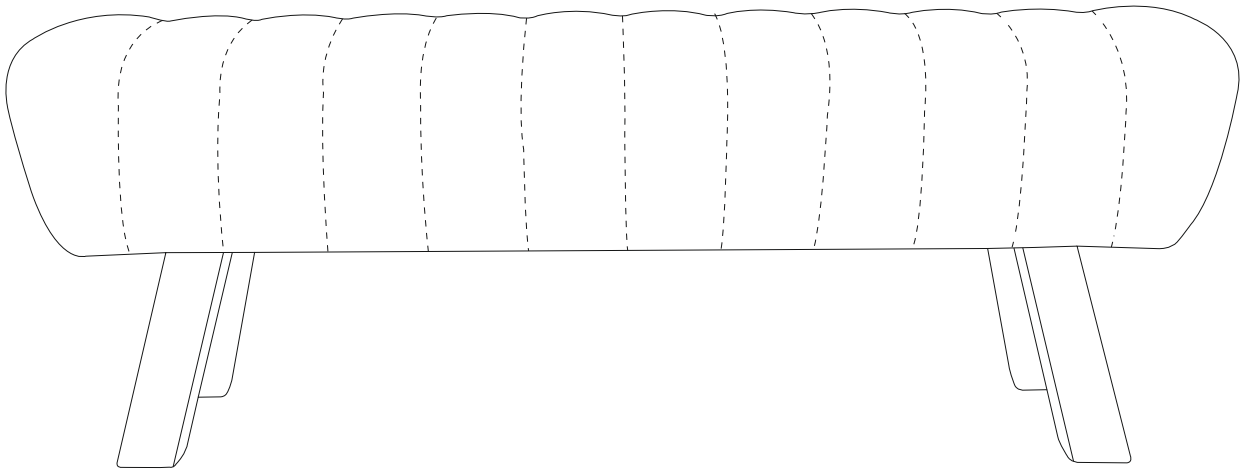

ASSEMBLY REQUIRES ONE PERSON



05 MIN ASSEMBLY TIME



KEEP INSTRUCTION FOR FUTURE USE



ASSEMBLY INSTRUCTIONS

Item #53001966

1

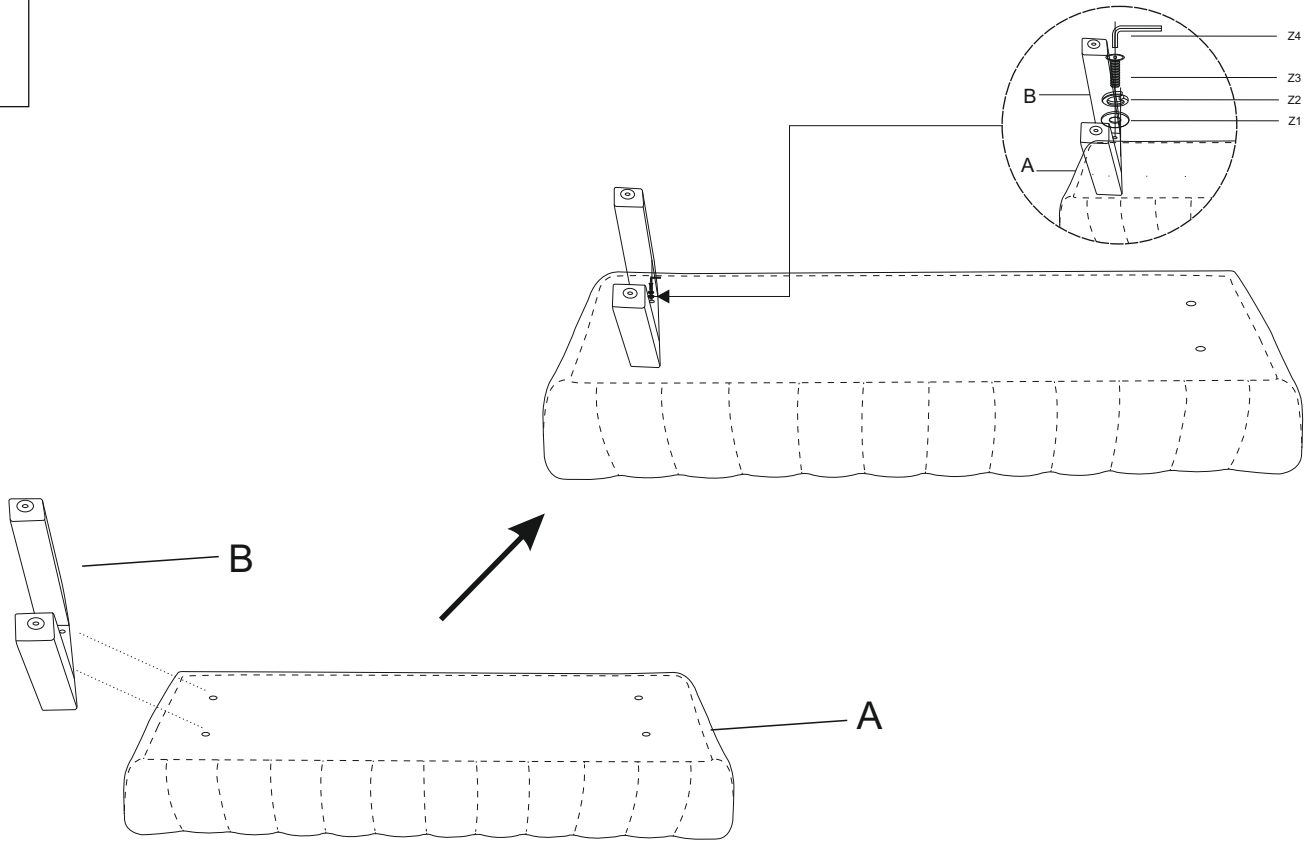

2

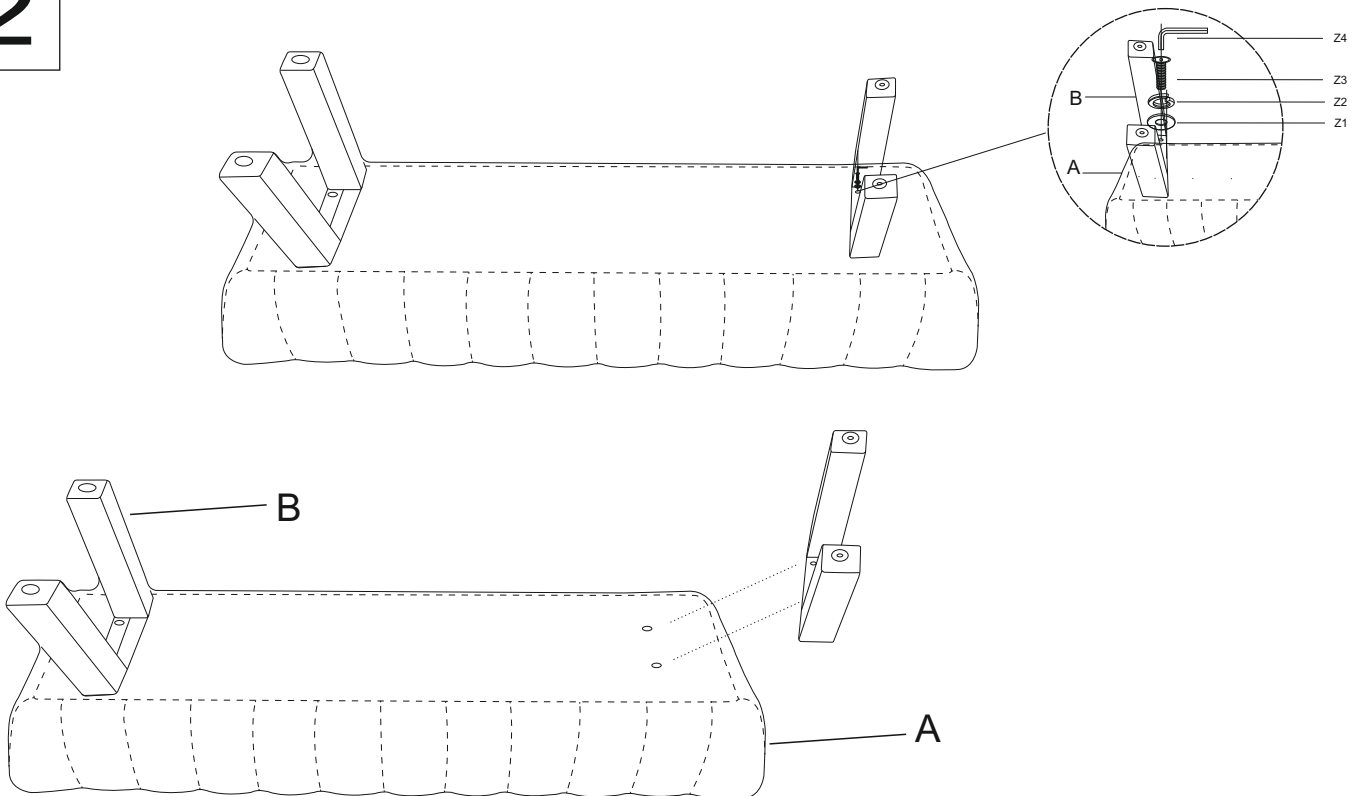

ASSEMBLY INSTRUCTIONS

Item #53001966

3

