

Water Pump Fountain

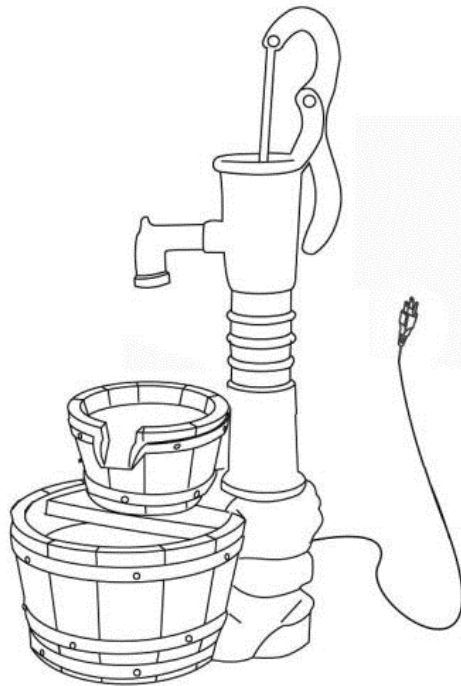

Parts List:

A. Top Pump Qty: 1

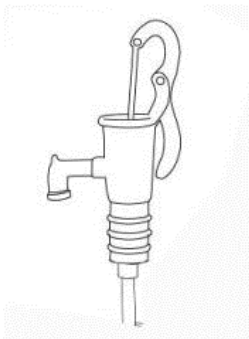

B. Bottom Barrel Qty: 1

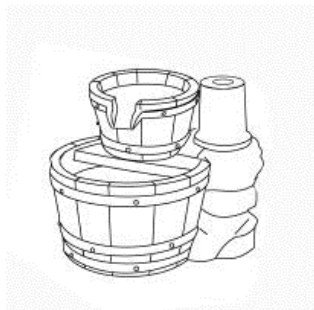

C. Pump Qty: 1

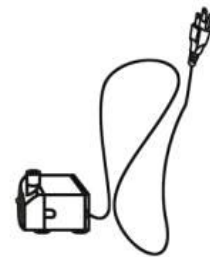

To Assemble:

Step 1: Route the pre-assembled water hose on the pump (A) to the bottom (B).

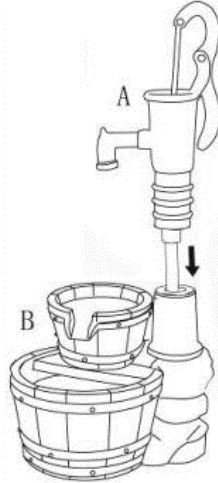

Step 2: Fill the basin of the polyresin barrel (B) with clean water, making sure the pump (C) is fully submerged.

Note: The maximum water level should be approximately 1.2 inches below the top edge of the basin (B).

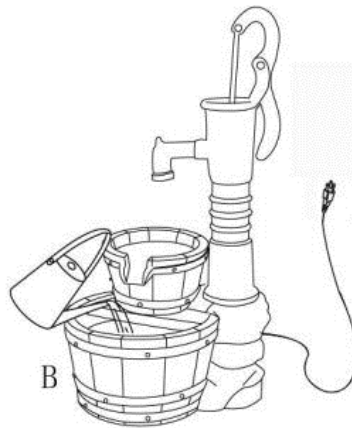

Step 3: Finally, connect the plug of pump (C) to a GFCI outlet.

WARNING: Always disconnect the pump (C) before placing your hands in the water.

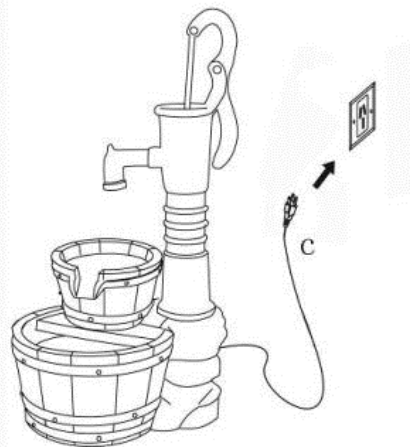

CARE AND MAINTENANCE

- I To eliminate the possibility of water damage to areas around the fountain, check for leaks and excessive splashing after the initial set up of the fountain. It is highly recommended this fountain be placed in an area where it cannot be damaged.
- I Do not leave the fountain running for extended periods of time when no one is present to observe the performance.
- I Check the area around the fountain on a regular basis to ensure there is no leakage.
- I Do not attempt to move fountain once filled with water.