

Assembly Instructions

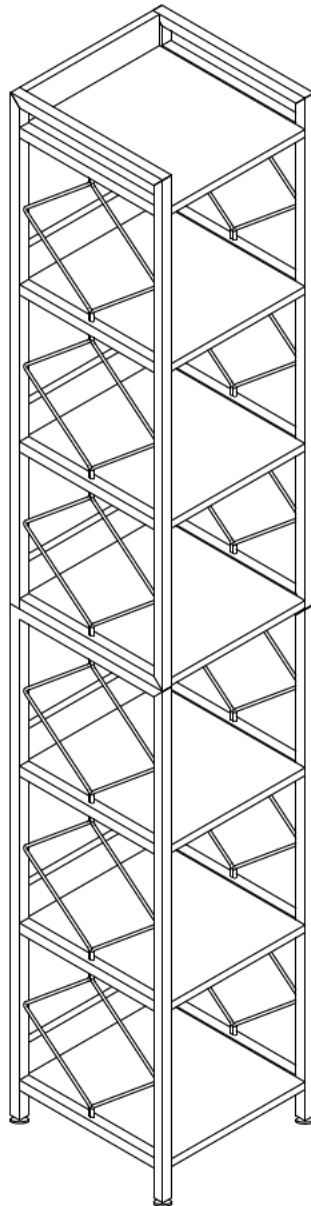

Bookcases

Assembly Instructions:

1. Carefully read these instructions and keep them for future reference.
2. Refer to the parts list for guidance and ensure that you have all the pieces before starting the assembly process, if anything is missing, damaged, incorrect, contact us **FIRSTLY BEFORE** assembling.
3. When assembling, place all parts on a soft, clean, and flat surface, such as a carpet, to prevent any scratches.
4. To avoid misalignment of the holes, Please don't full tighten the screws until you ensure all parts in place.

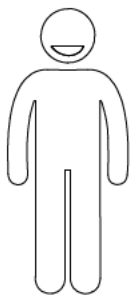

X2

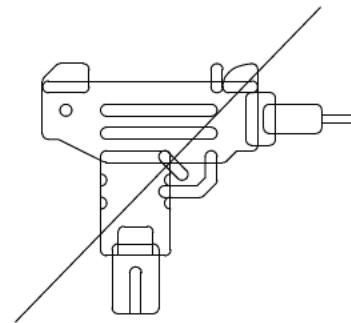
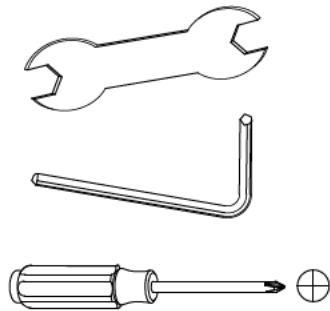

When using the electric screwdriver ,
Reduce the power and torque to avoid damaging the furniture

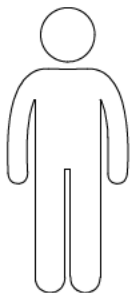

?

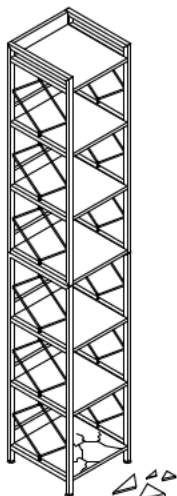
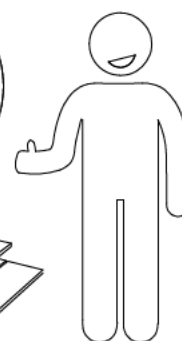
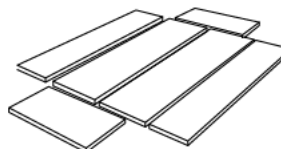
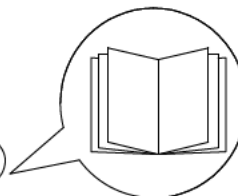
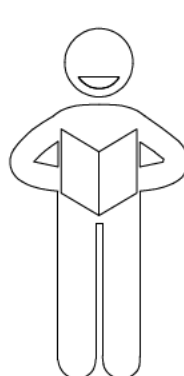
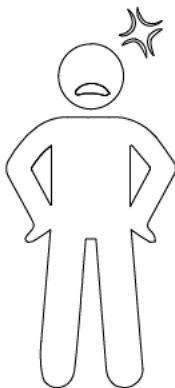
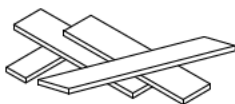

X

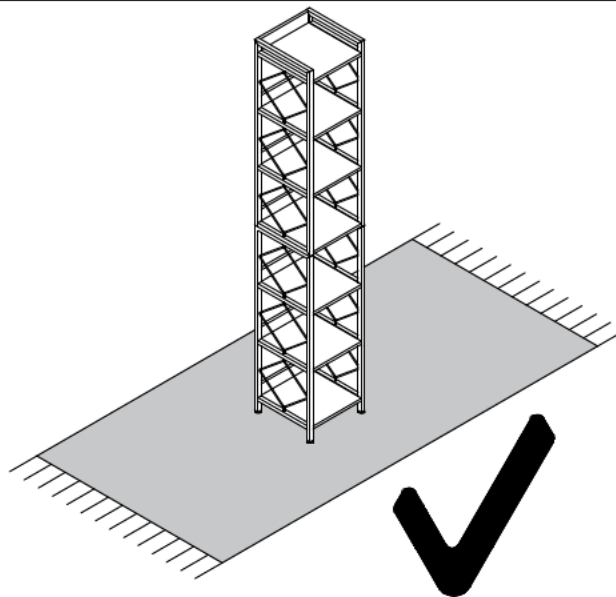

✓

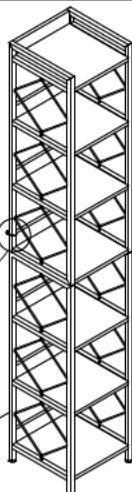

✓

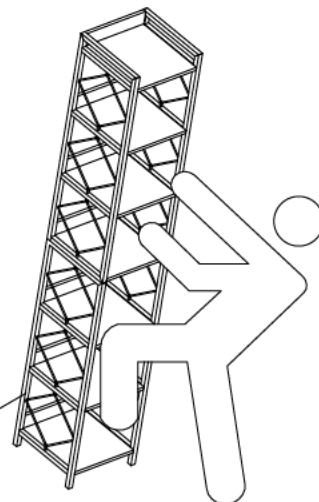

X

(Install tip-over restraint provided)
Use of tip-over restraints may only reduce but not eliminate,
the risk of tip-over.

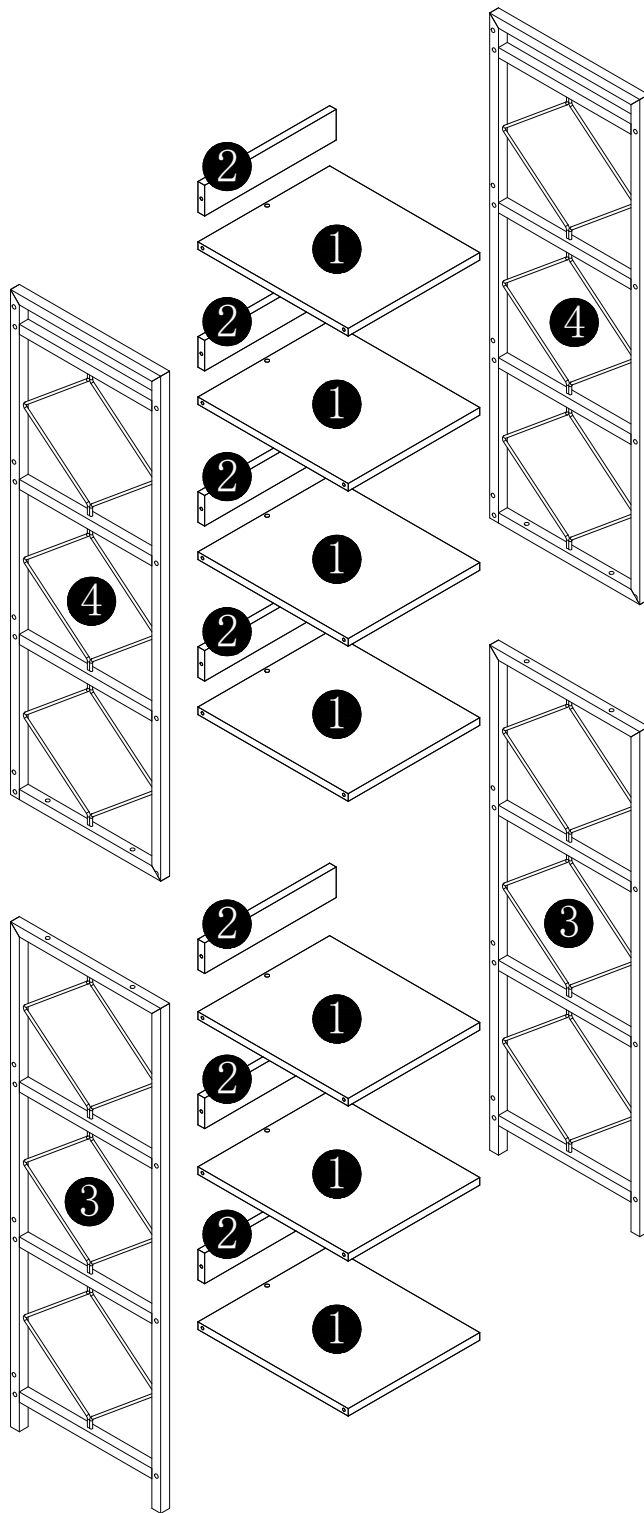

⚠ Caution

Make sure all parts are included. Most board parts are labeled or stamped on the raw edge. Contact us for free replacement if having damaged or missing parts.

Parts & Hardware List

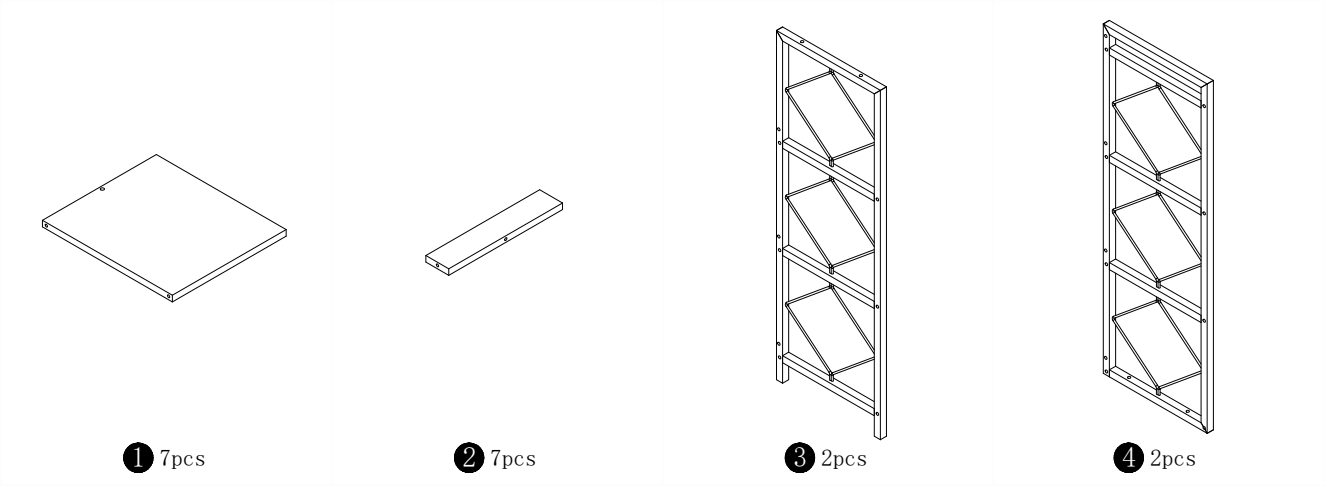

Parts & Hardware List

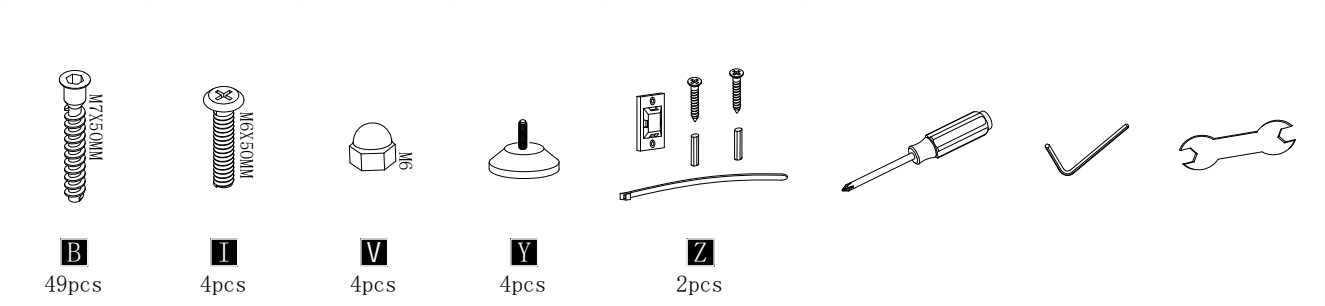

1

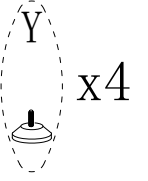
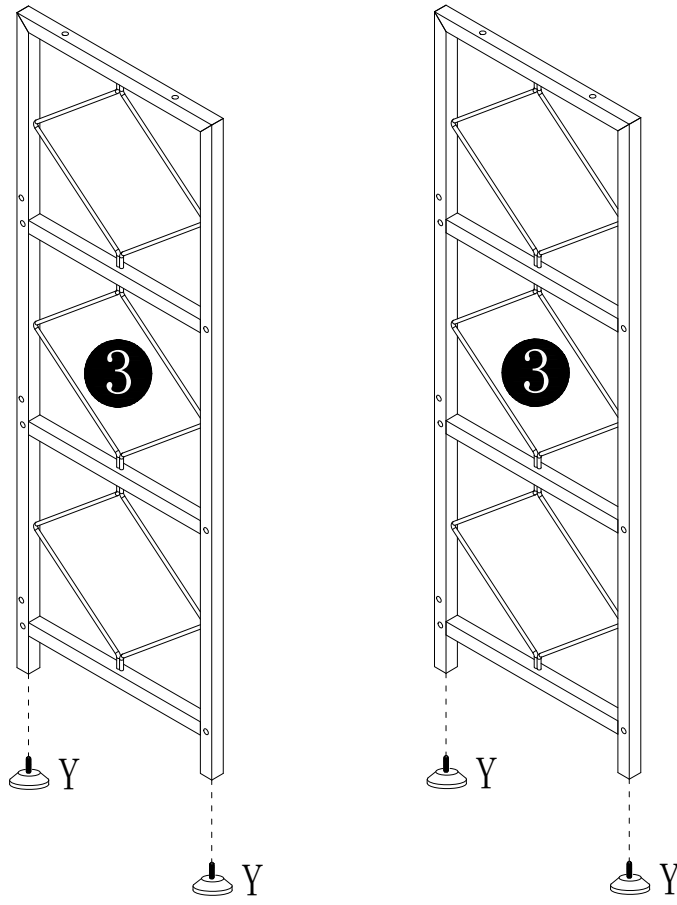

2

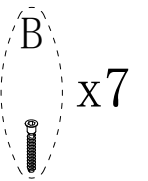
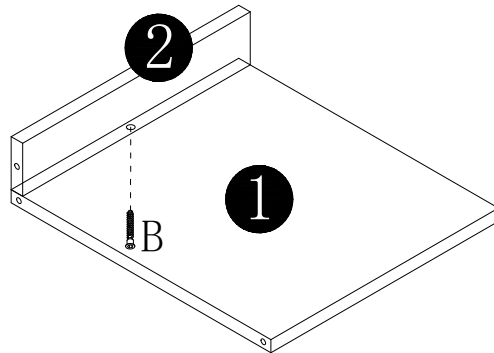
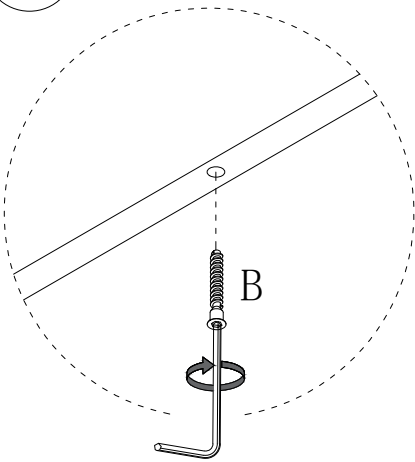

x7

3

B x18

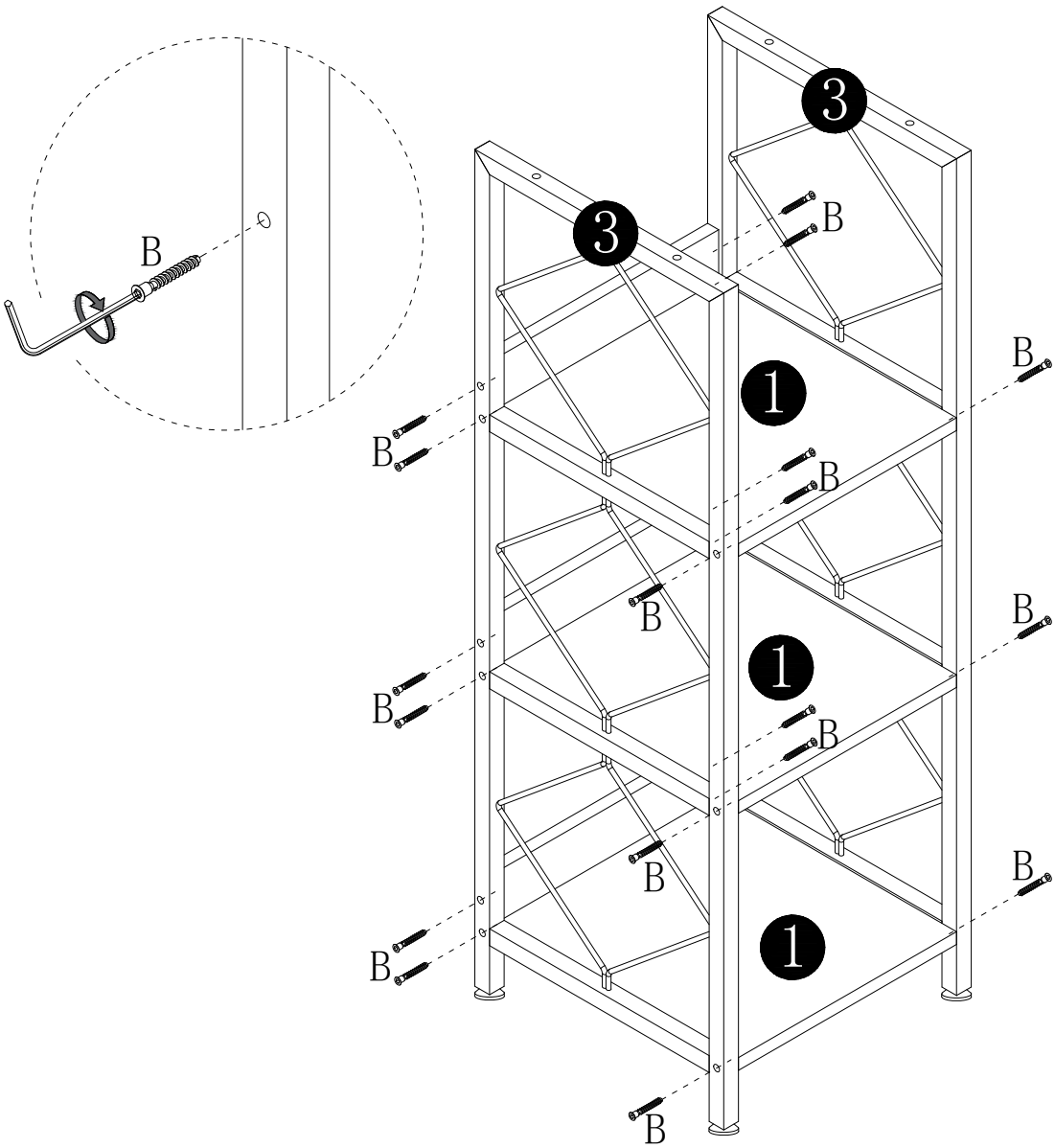

4

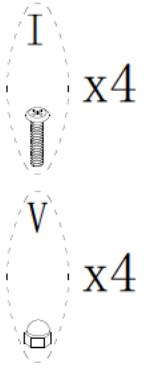
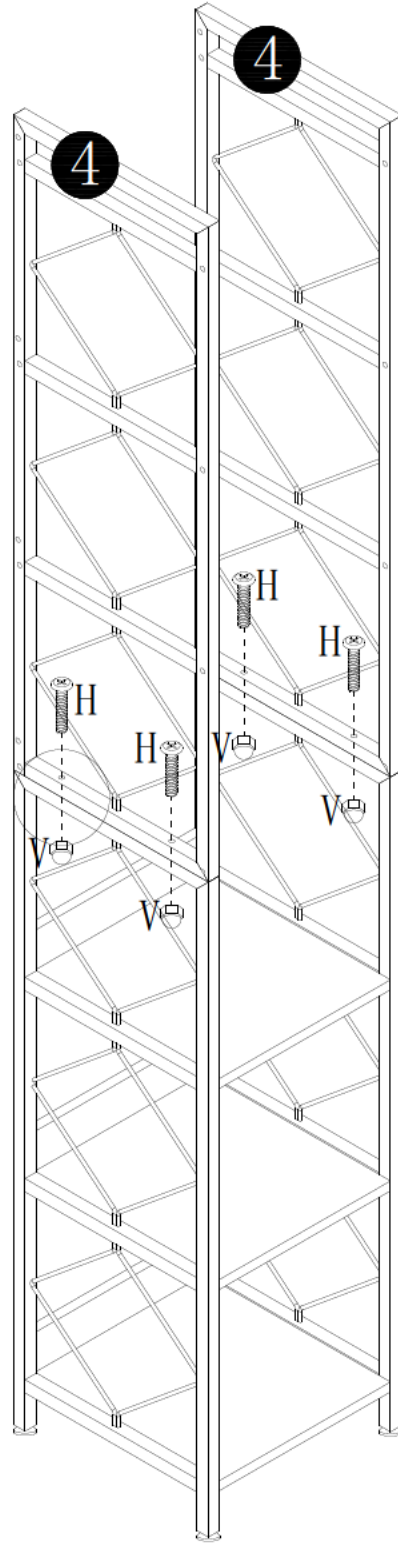
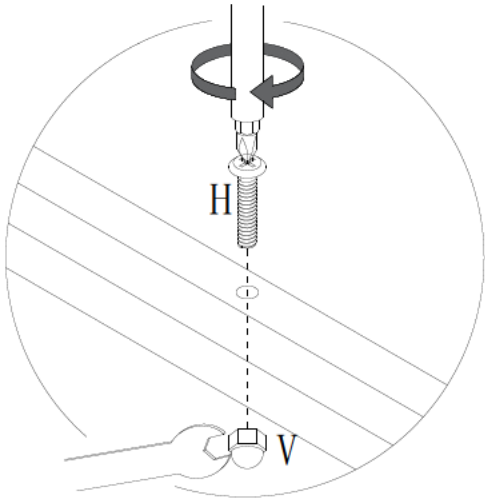

5

B x24

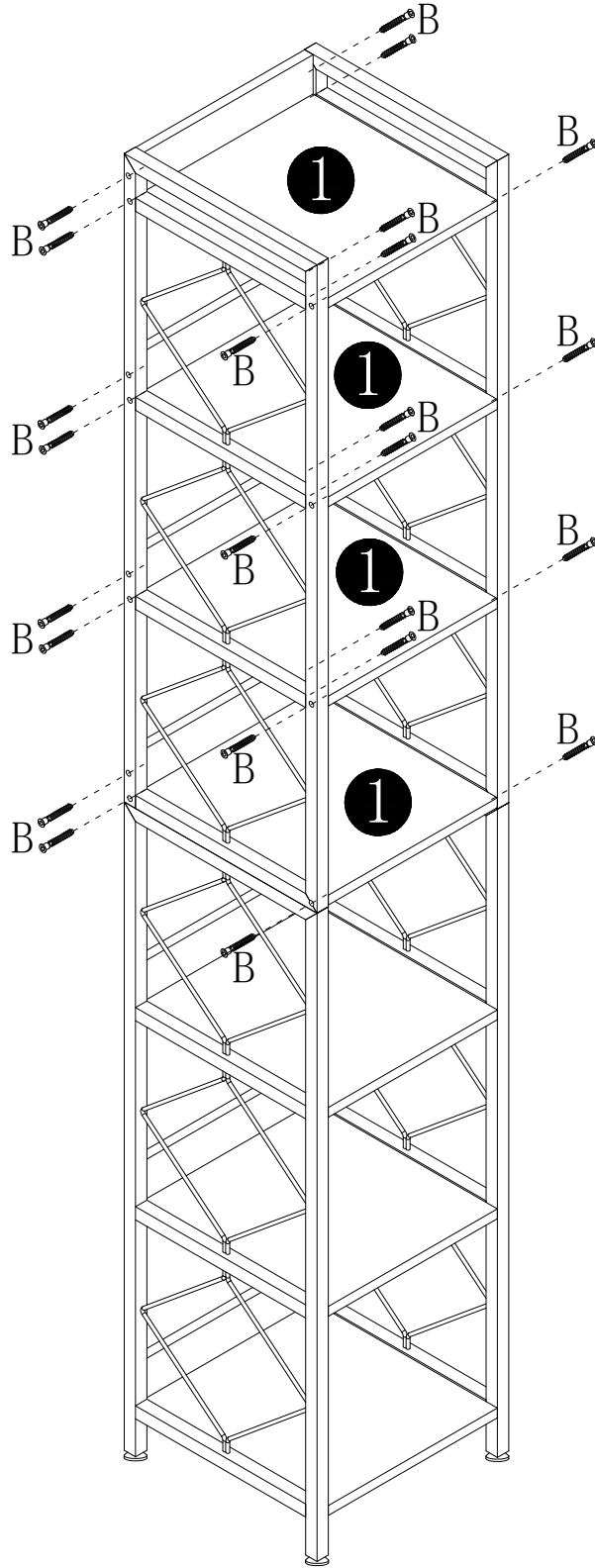
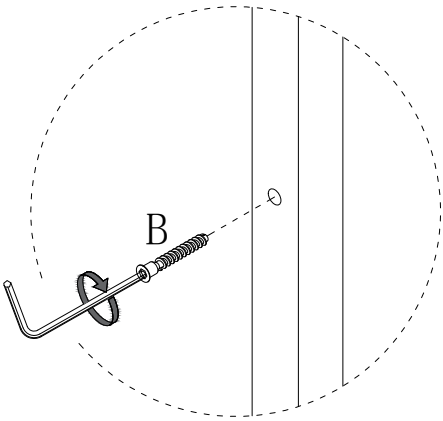

6

Z x2

