

Assembly Instruction

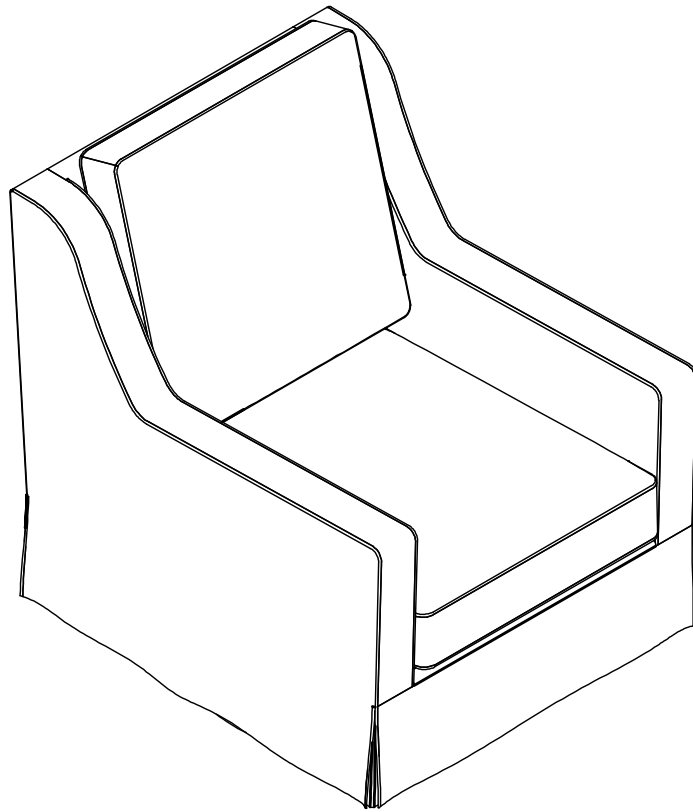

PARTS

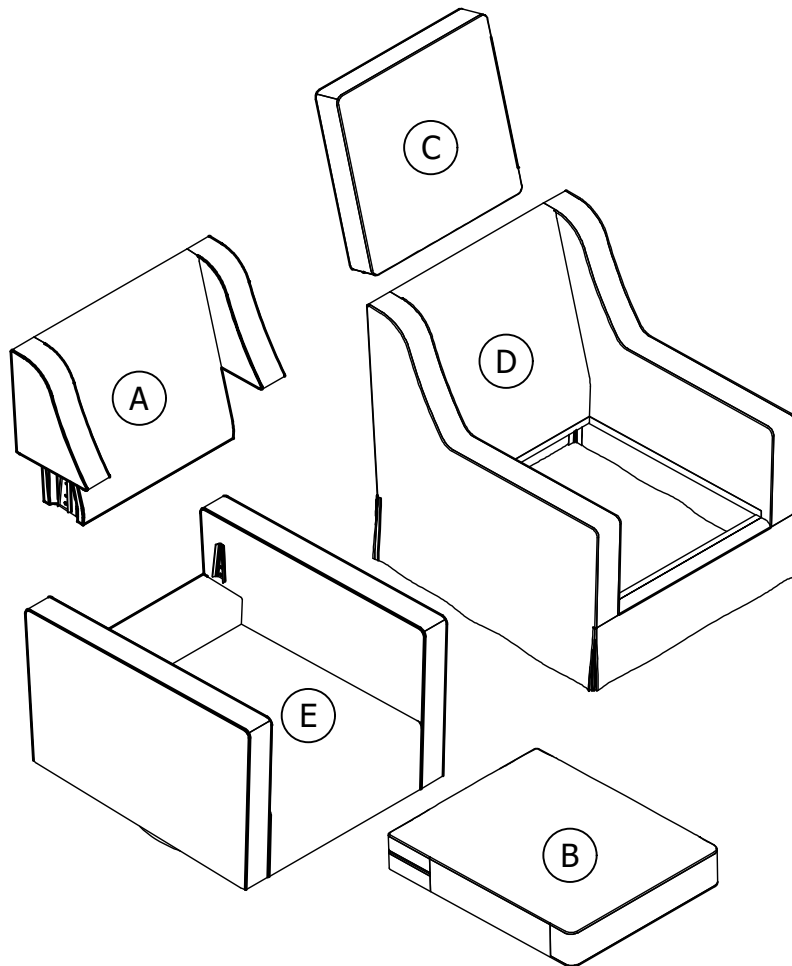

PARTS LIST

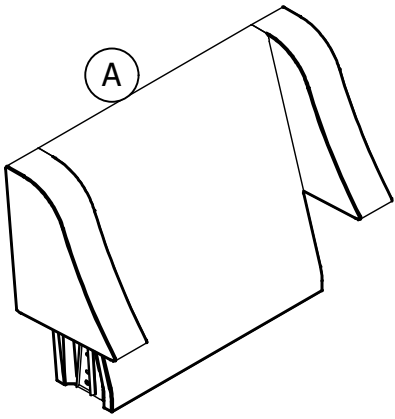

Back X 1 PC

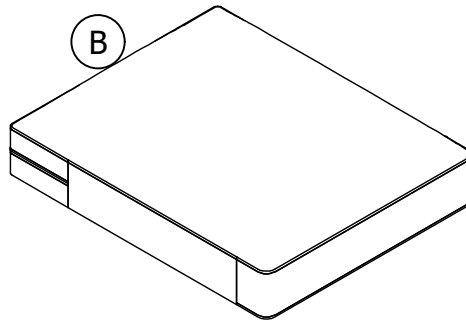

Seat Cushion X 1 PC

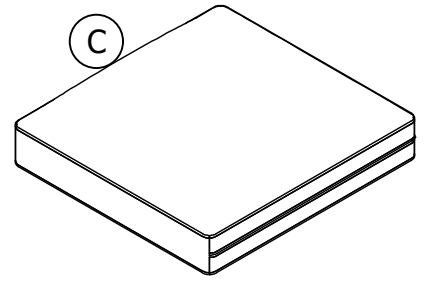

Back Cushion X 1 PC

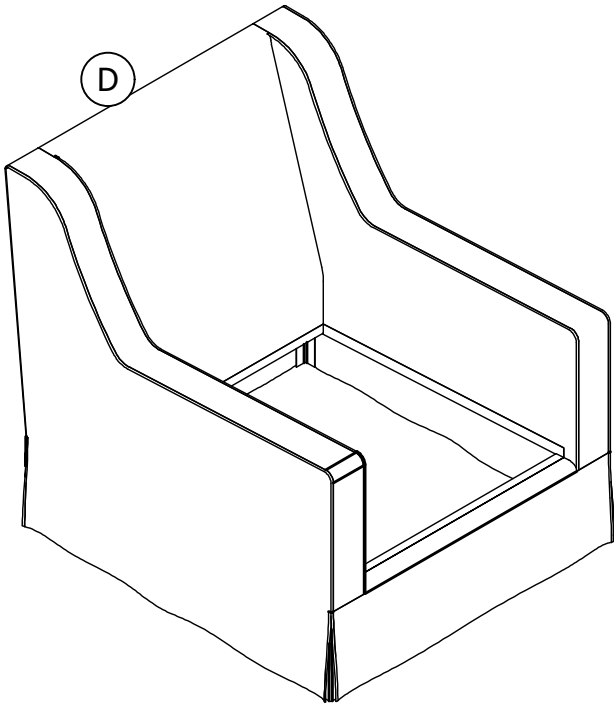

Chair Slipcover X 1 PC

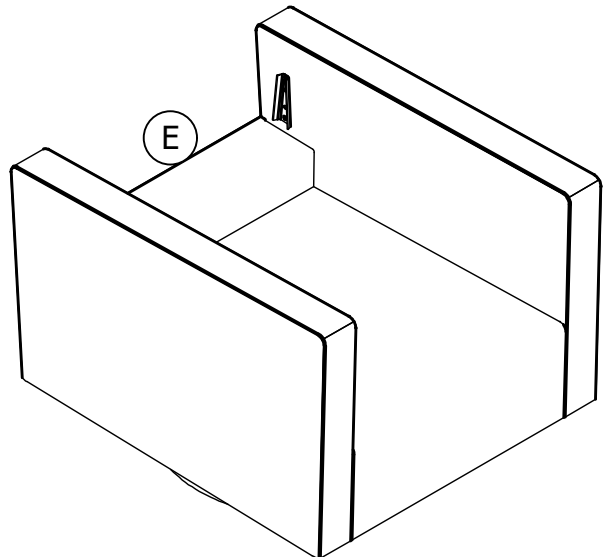

Seat Frame X 1 PC

Place all parts on a clean, smooth surface.

STEP 1: Remove the tie-wraps on Seat Frame **E**, as shown.

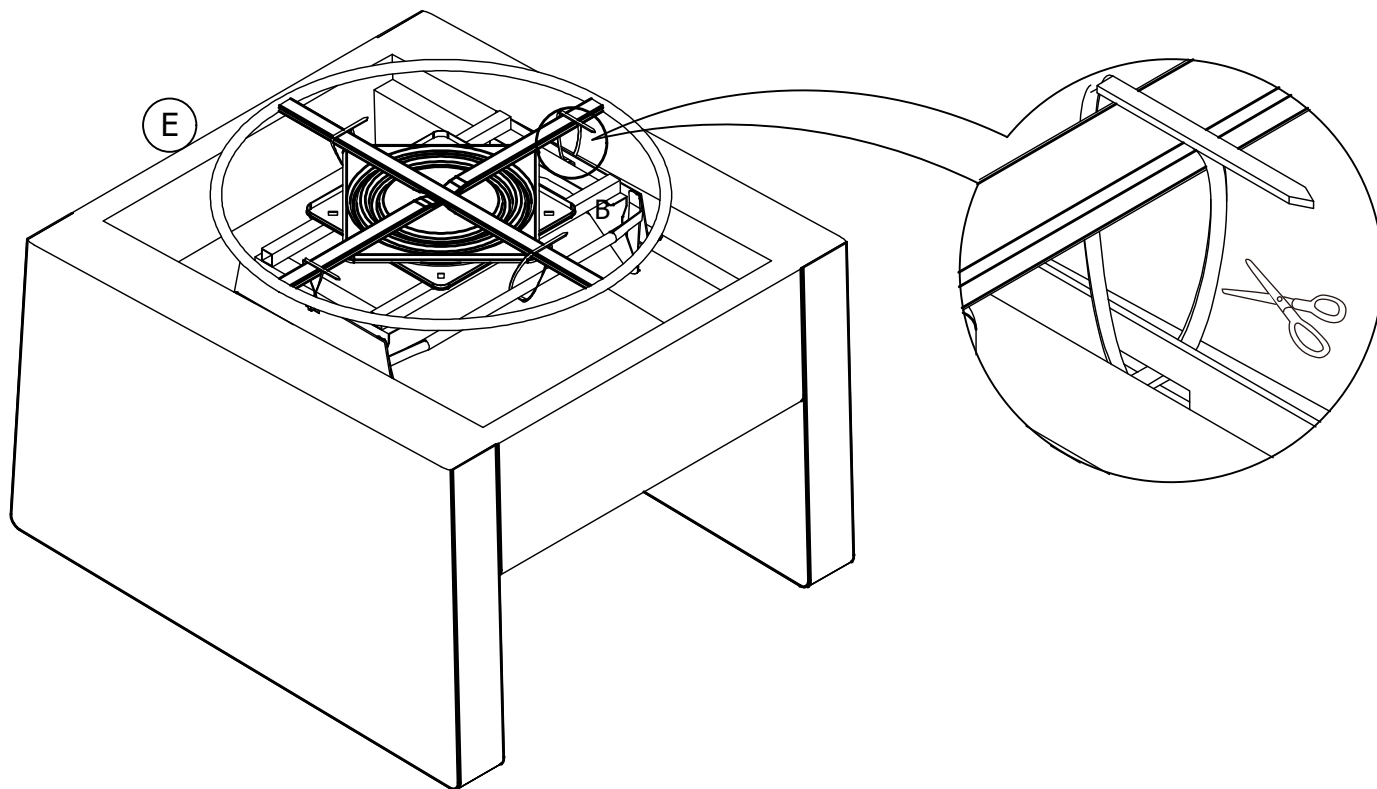

STEP 2:

Attach Back **A** to Seat Frame **E** by inserting the brackets on Back **A** onto the metal plate on Seat Frame **E**, as shown.

Push Back **A** with a downward force to secure it into place.

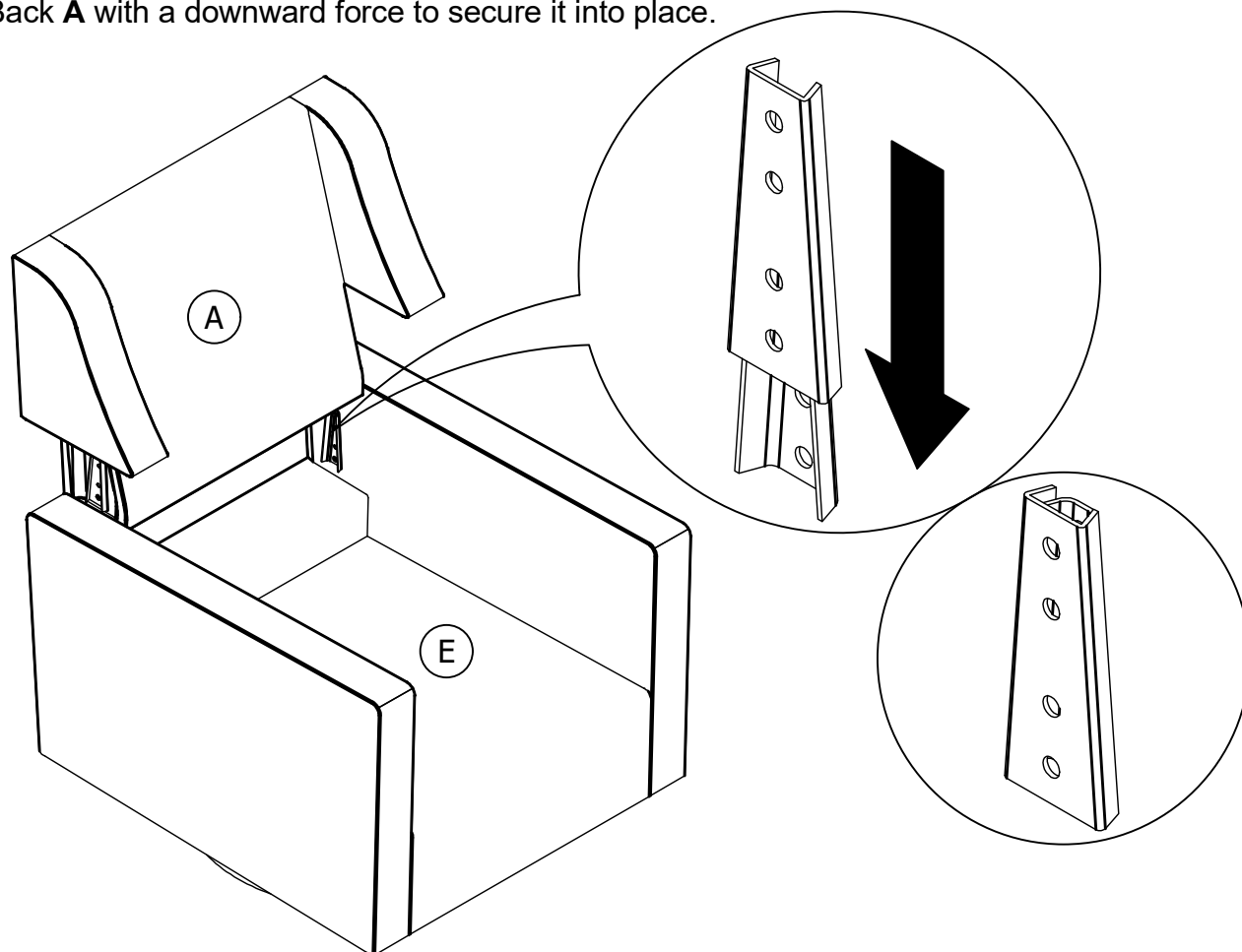

STEP 3: Put the chair slipcover **D** on the chair using the Velcro strips.

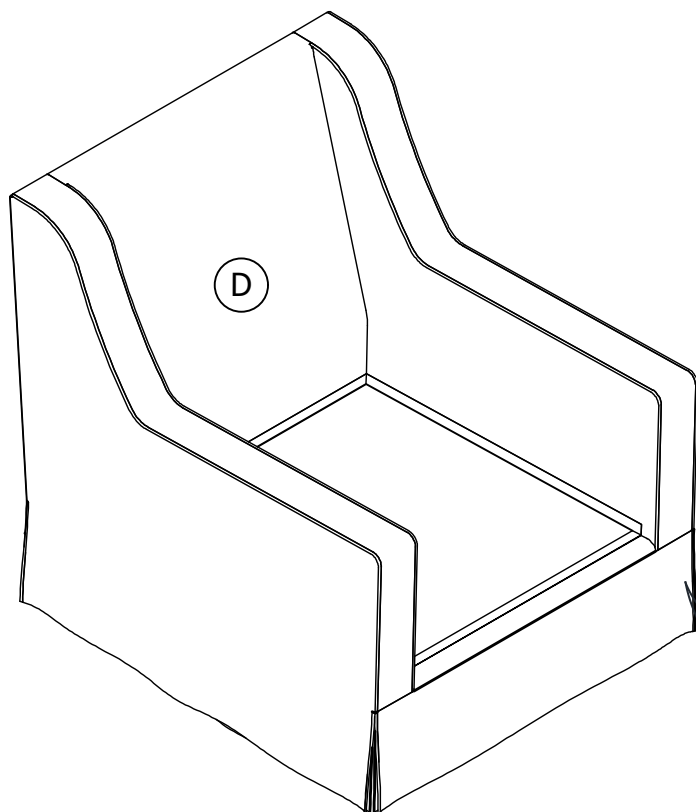

▲ Note: If necessary, iron the fabric cover with a steam iron to loosen wrinkles.

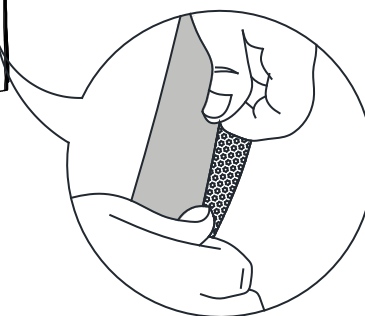

Step 4: Place Seat Cushion **B** and Back Cushion **C** onto the chair.

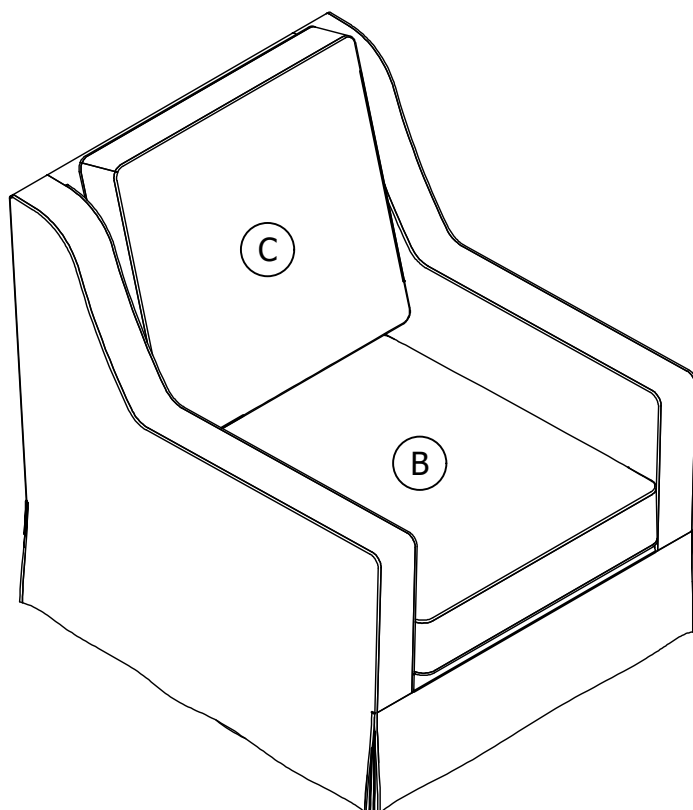

Step 5: You can swivel the chair.

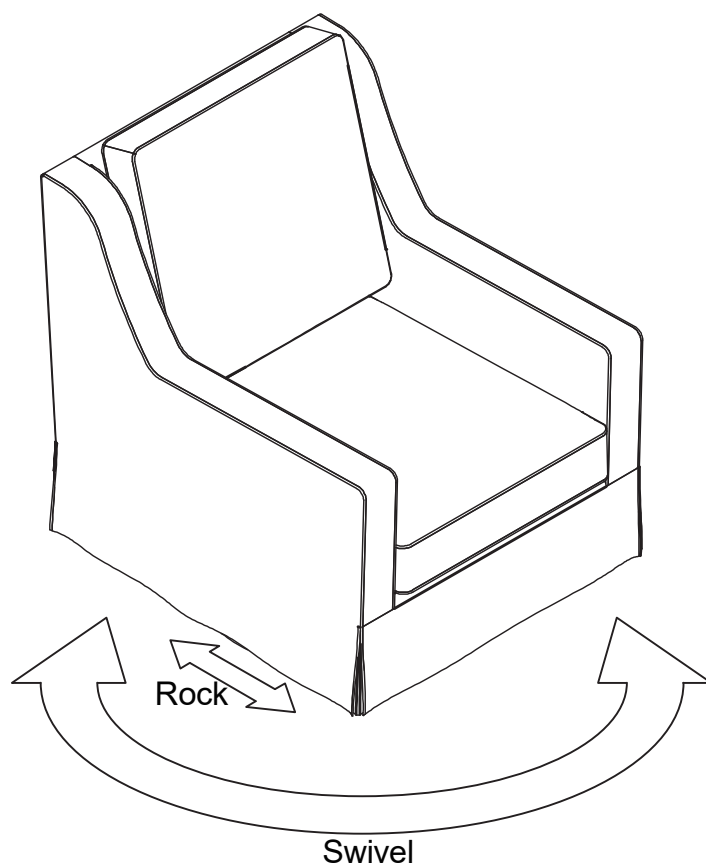

Helpful Hints

- Move your new furniture carefully, with two people lifting and carrying the unit to its new location.
- Your furniture can be disassembled and reassembled to move.
- Clean the product with a soft damp cloth. DO NOT use harsh chemicals or abrasive cleaners.
- For further information please contact at sales4@jsanyee.com

