

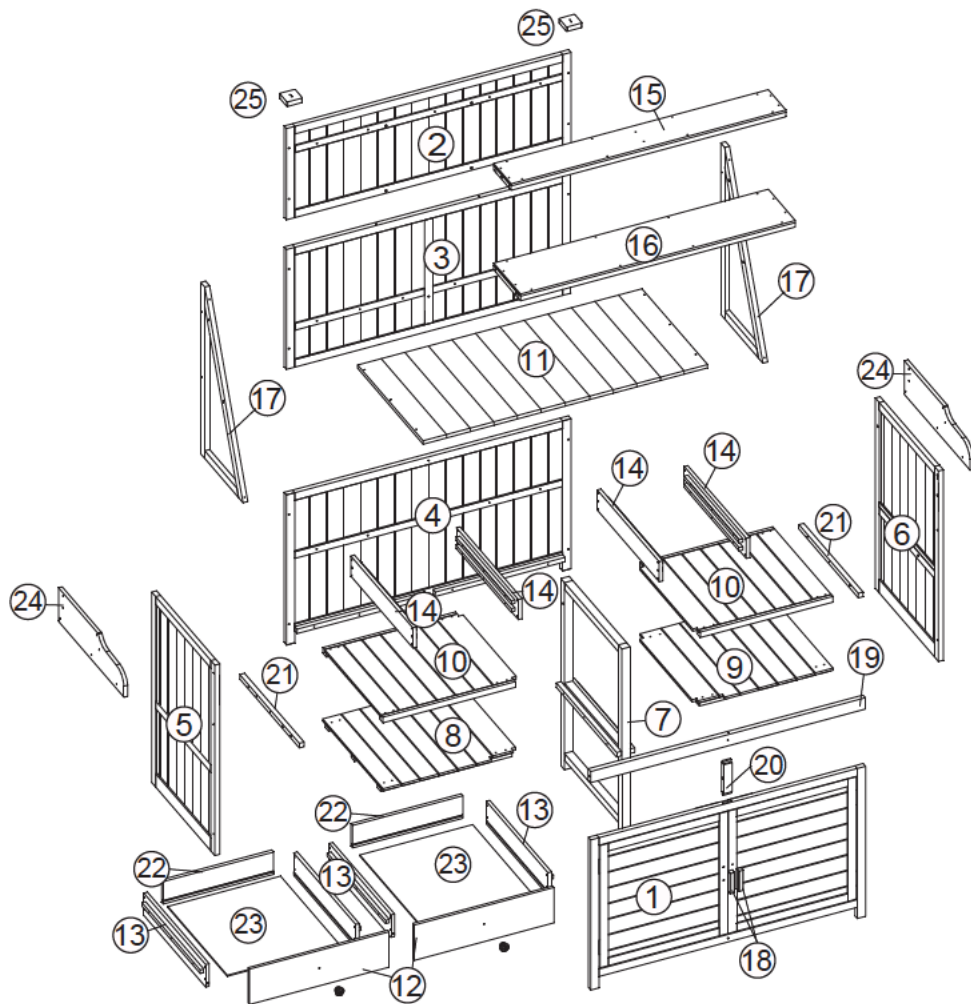



This set includes 2 boxes. If not receive full 2boxes,please contact our customer service team.

## Detail View

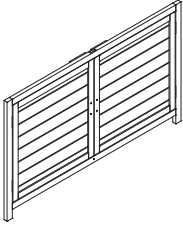
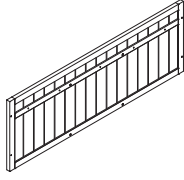
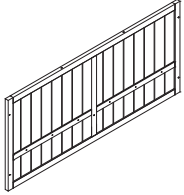
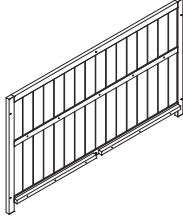
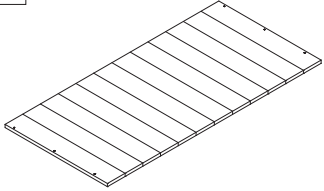
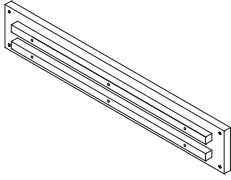
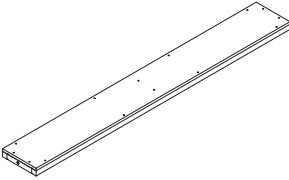
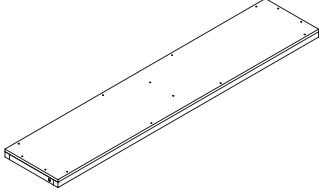
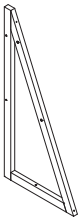

Part List

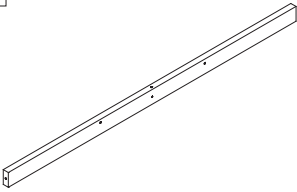

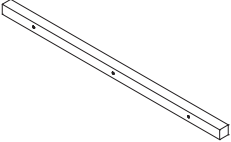
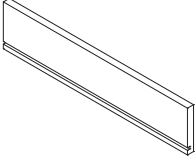
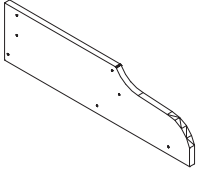
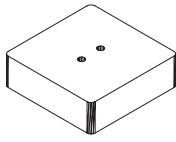



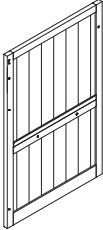
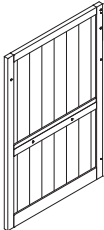
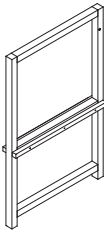
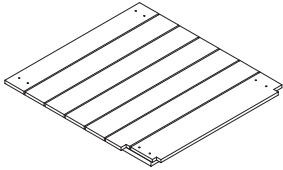
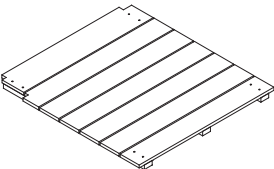
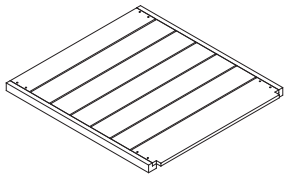
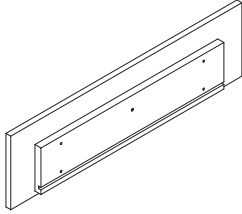
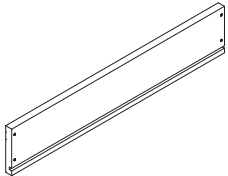
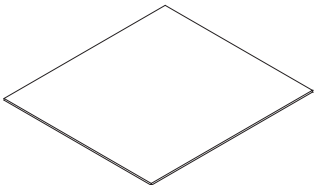

Hardware list

1 	2 	3 	4 
Front panel - 1pc	Upper back panel- 1pc	Middle back panel- 1pc	Lower back panel- 1pc
11 	14 	15 	16 
Table top - 1pc	Support plate of drawer - 4pcs	Upper storage board - 1pc	Lower storage board - 1pc
17 	18 	19 	20 
Triangular support part - 2pcs	Handle - 2pcs	Horizontal bar of front panel - 1pc	Vertical bar of front panel- 1pc
21 	22 	24 	25 
Slat of support - 2pcs	Back part of drawer - 2pcs	Side panel of table - 2pcs	Wood block - 2pcs

Hardware list

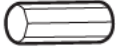
5 	6 	7 	8 
Left panel - 1pc	Right panel - 1pc	Middle panel - 1pc	Bottom panel 1 - 1pc
9 	10 	12 	13 
Bottom panel 2 - 1pc	Shelves - 2pcs	Front part of drawer - 2pcs	Side part of drawer - 4pcs
23 			
Bottom of drawer - 2pcs			

# Hardware List

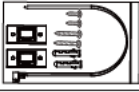
<b>A</b>  φ3.5x60 Ph zinc screws 4+1pcs	<b>B</b>  φ3.5x40 Ph zinc screws 25+1pcs	<b>C</b>  φ3.0x38 Ph zinc screws 14+1pcs	<b>D</b>  φ3.0x30 Ph zinc screws 56+1pcs
<b>E</b>  Wood dowel 16pcs	<b>F</b>  M6*45 Ph zinc bolt 8+1pcs	<b>G</b>  M4*35 Ph zinc bolt 2+1pcs	<b>H</b>  Door Knob 2pcs
 Anti-topple over sets 2pcs			

## ASSEMBLY TOOLS REQUIRED(NOT INCLUDED)



PLEASE BE CAREFUL DO NOT DAMAGE THE HOLE POSITION WHEN YOU USE POWERTOOLS!

### Step1

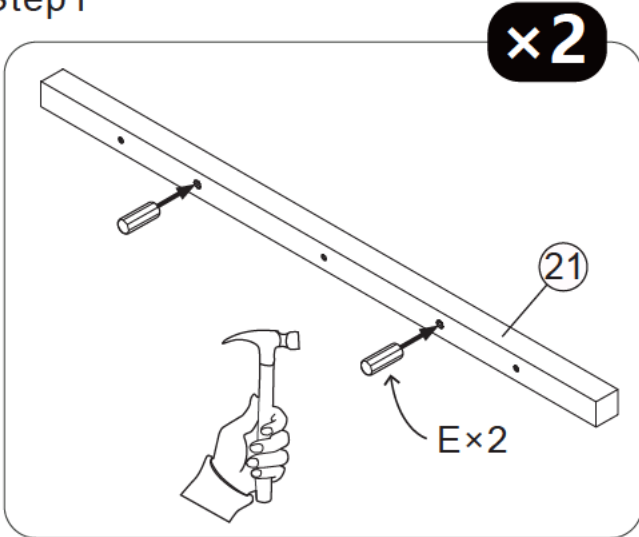

E×4 ②1×2

### Step2

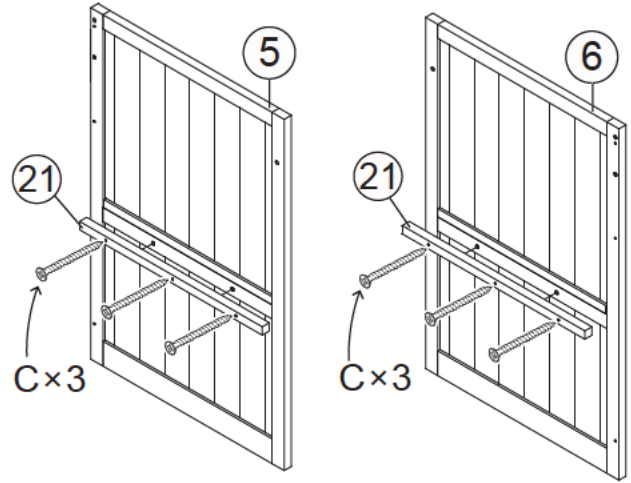

C×6 ⑤×1 ⑥×1

### Step3

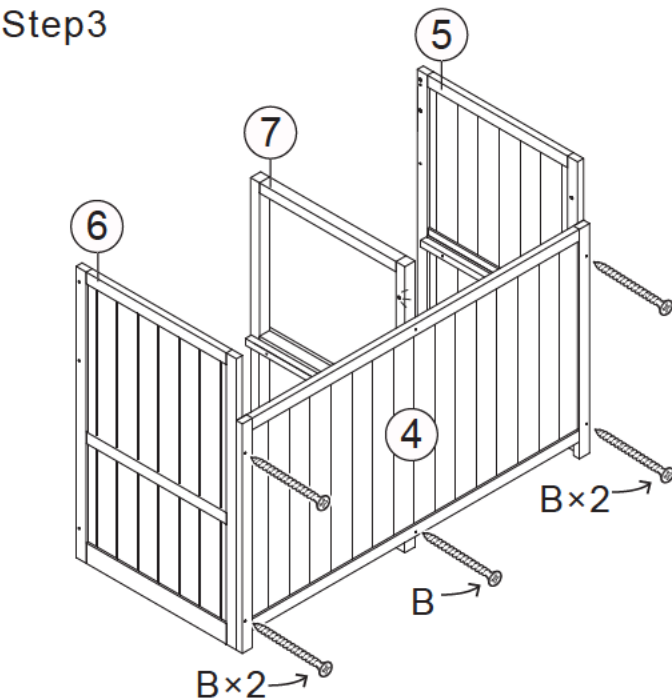

B×5 ④×1 ⑦×1

### Step4

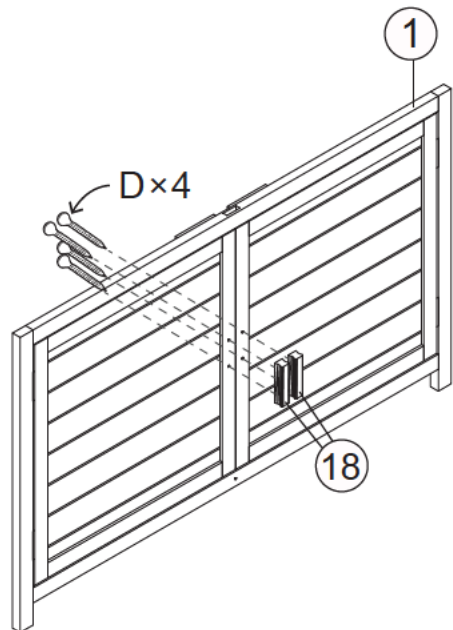

D×4 ①×1 ⑱×2

Step5

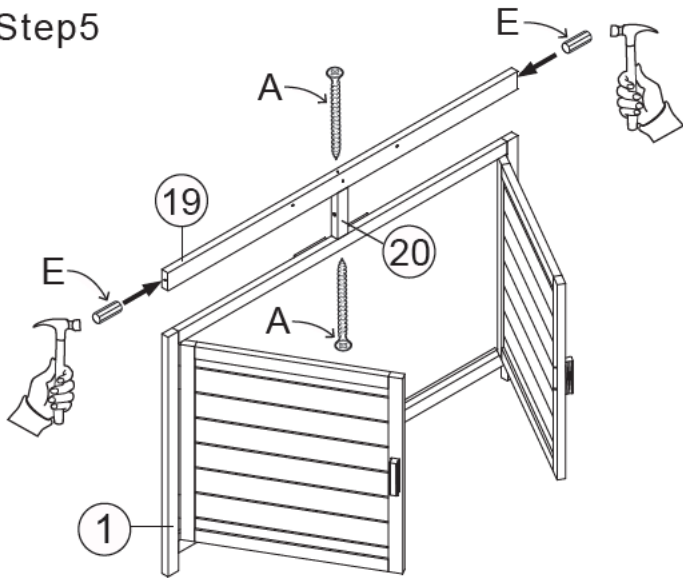

A×2 E×2 19×1 20×1

Step6

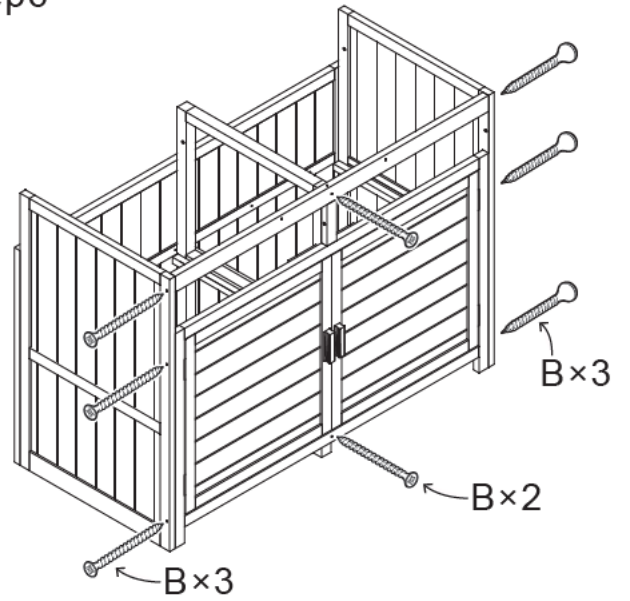

B×8

Step7

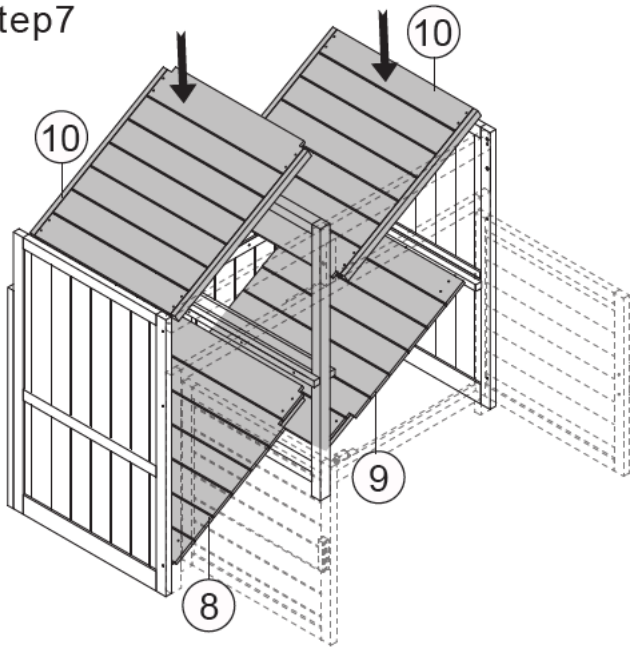

8×1 9×1 10×2

Step8

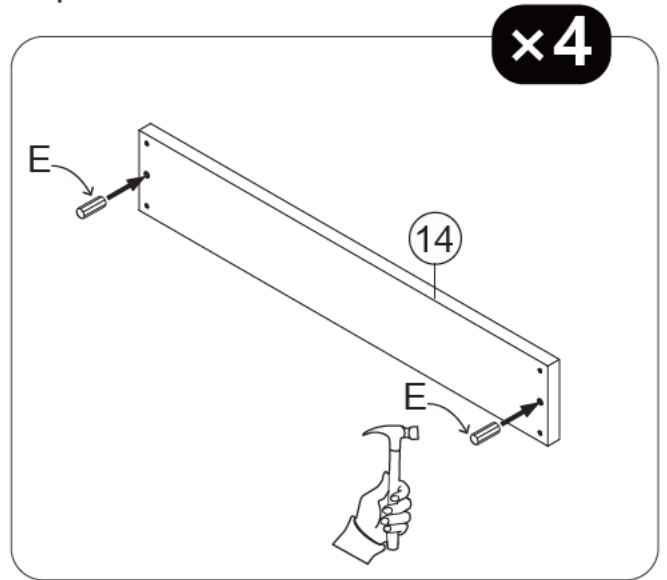

E×8 14×4

Step9

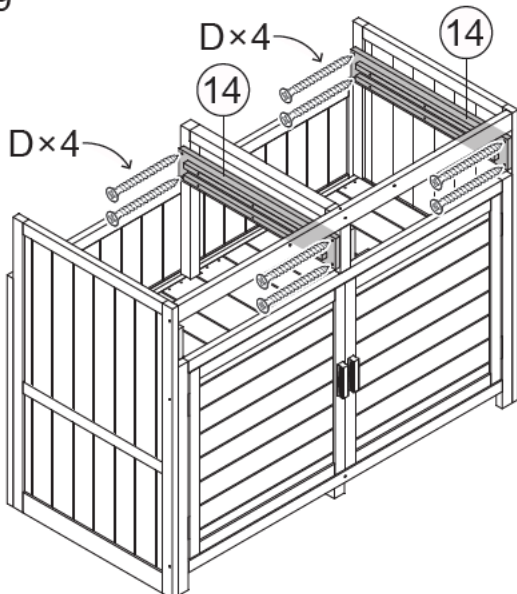

B×1 D×16

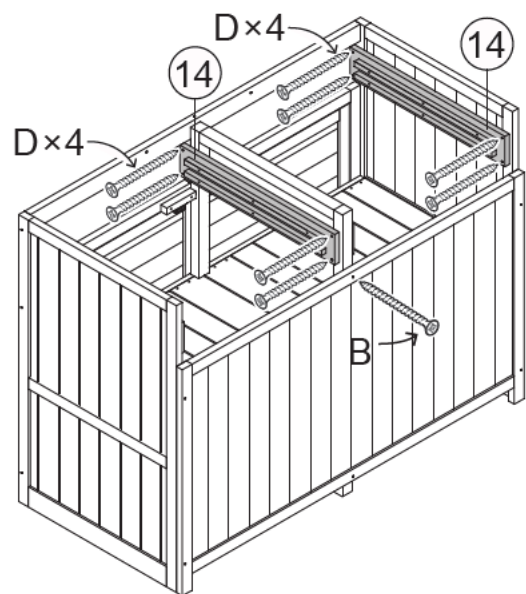

Step10

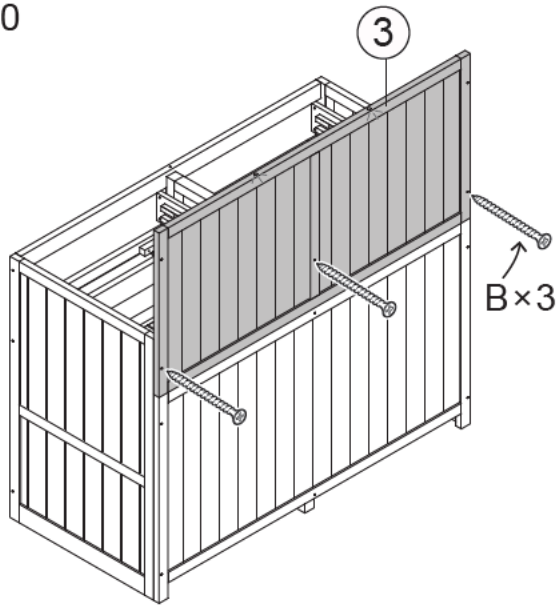

Bx3 ③x1

Step11

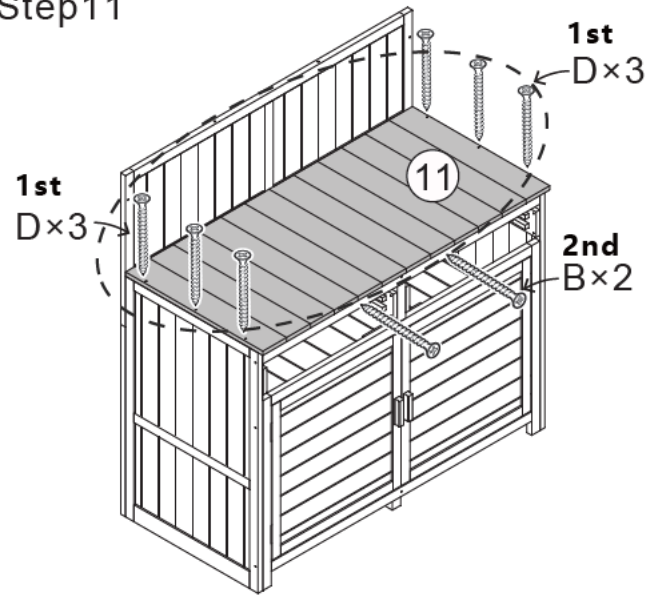

Bx2 Dx6 ⑪x1

Step12

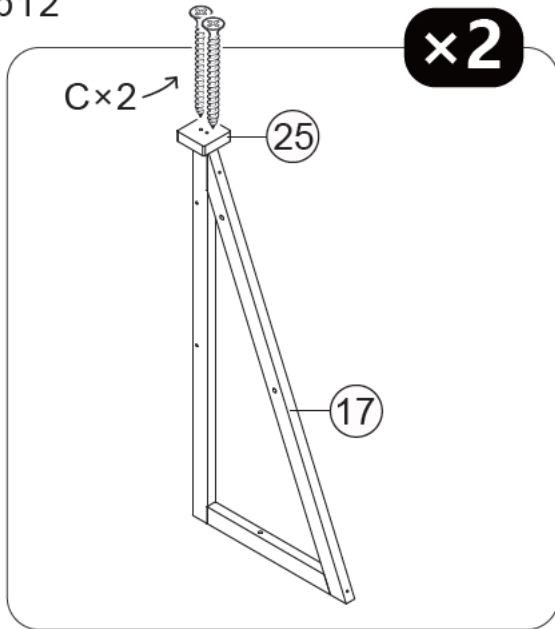

Cx4 ⑰x2 ⑳x2

Step13

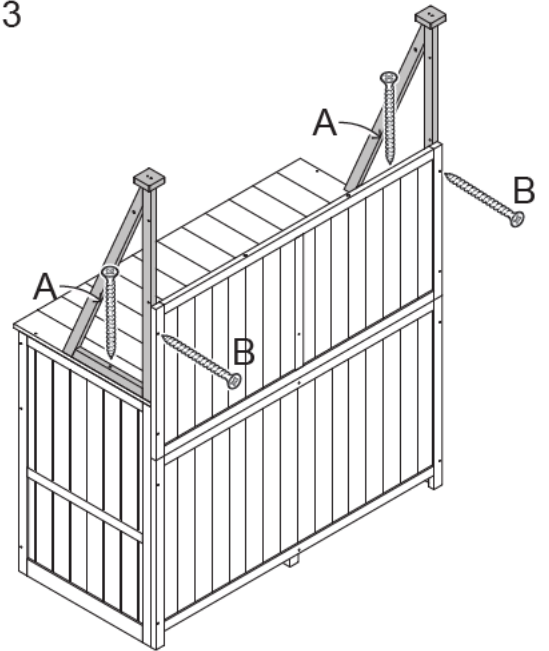

Ax2 Bx2

Step14

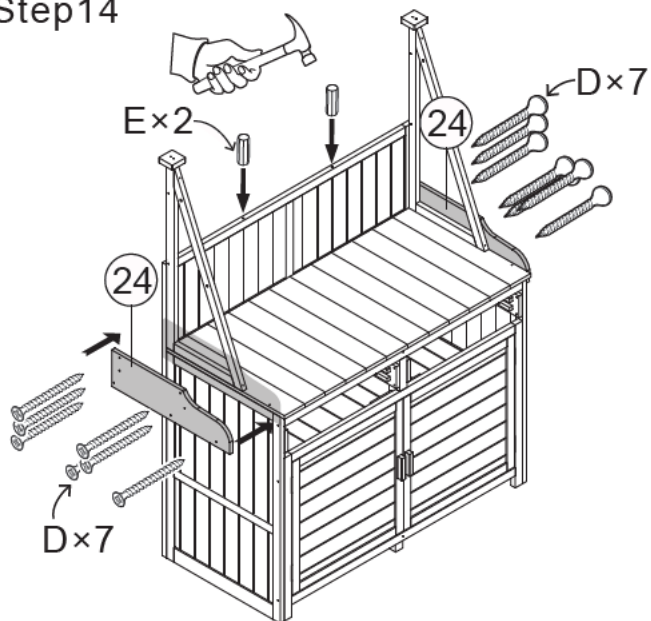

Dx14 Ex2 ⑳x2

Step15

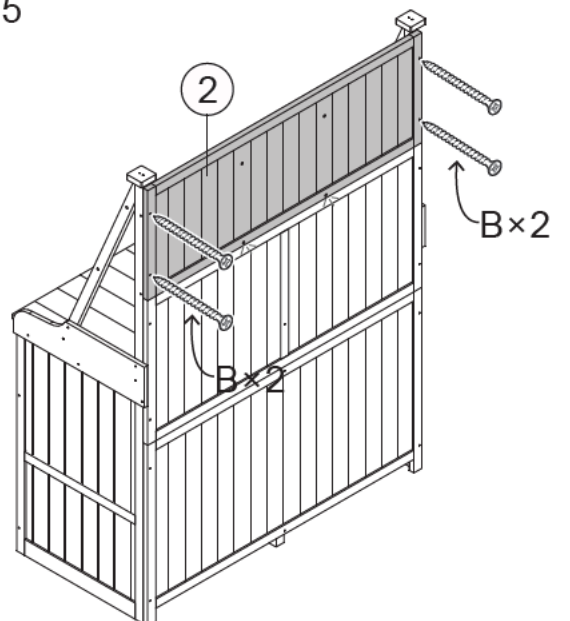

Bx4 ②x1

Step16

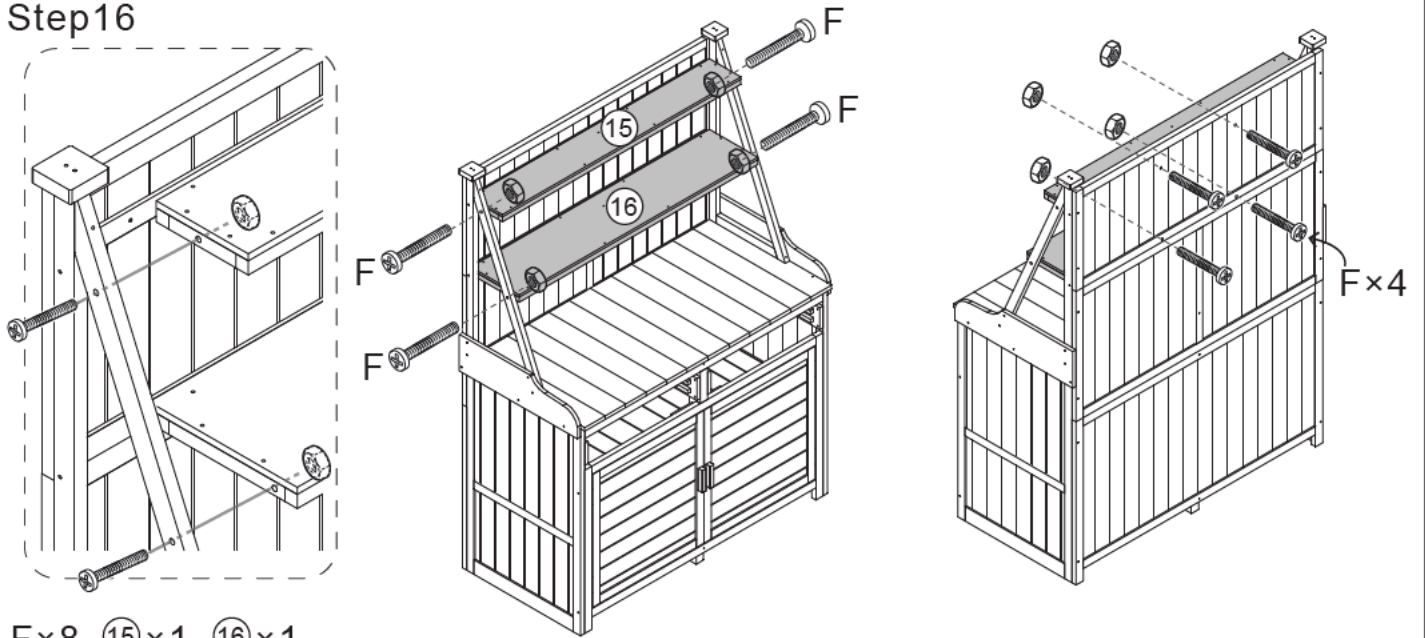

F×8 ⑮×1 ⑯×1

Step17

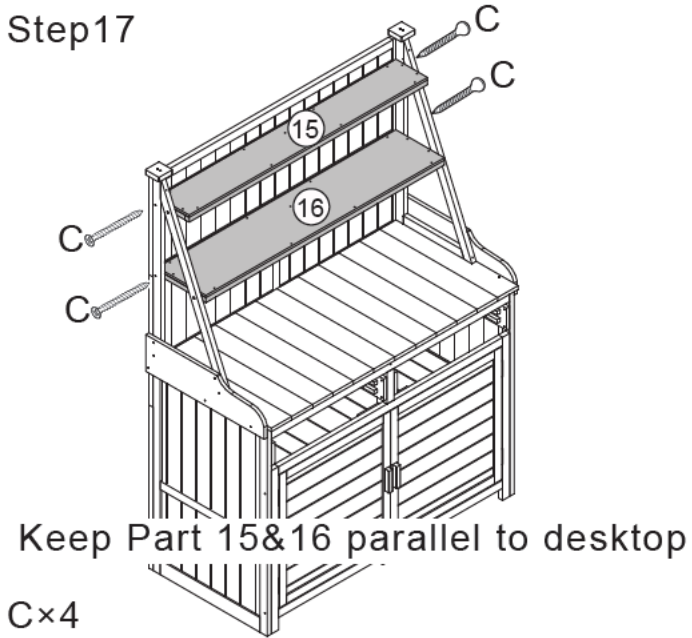

C×4

Step18

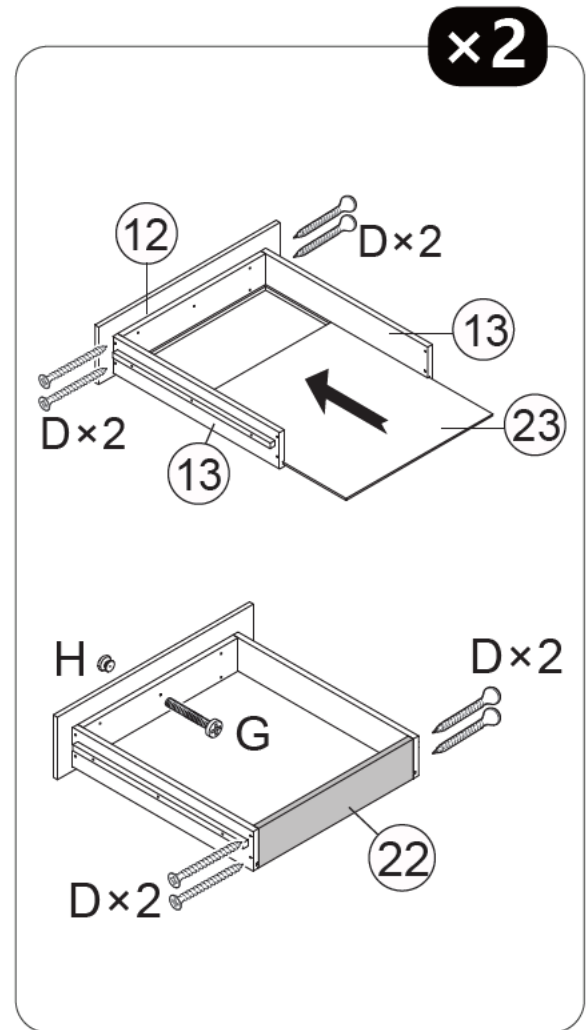

Step19

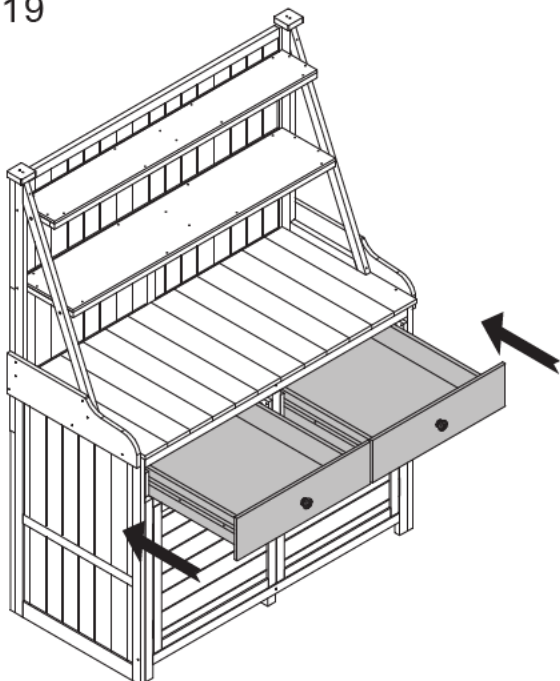

D×16 G×2 H×2 ⑫×2 ⑬×4 ⑰×2 ⑱×2

Step20

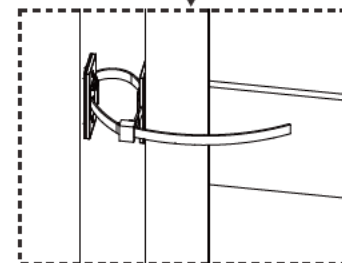
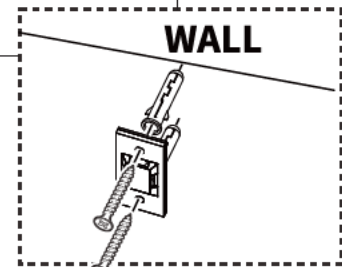
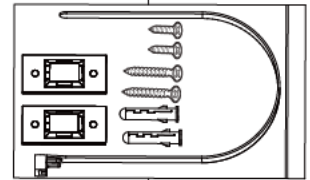
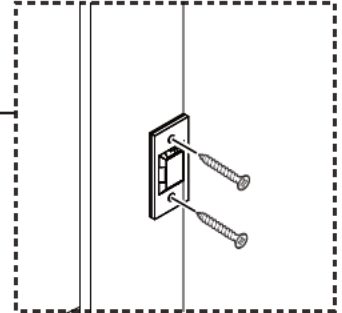
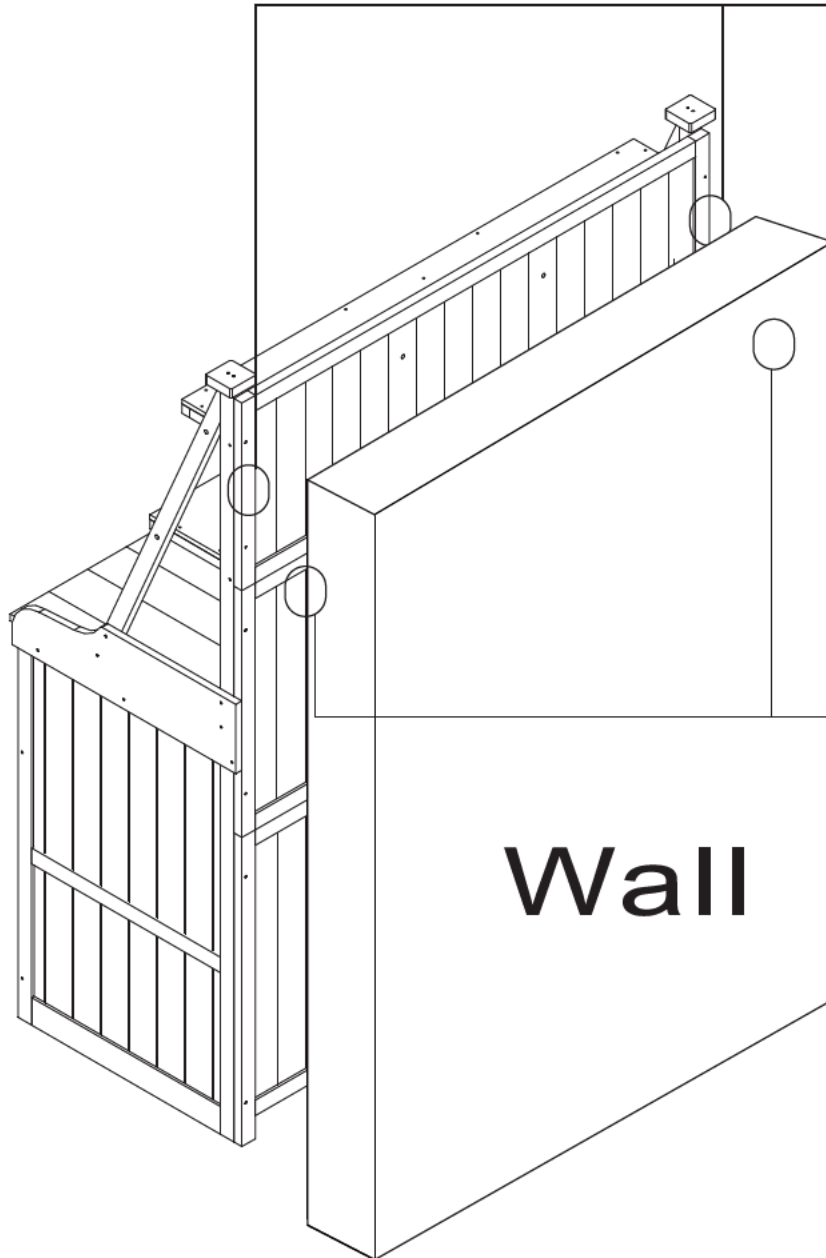

Done