

ASSEMBLY INSTRUCTION

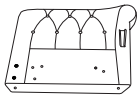

A x 1 pc

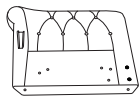

B x 1 pc

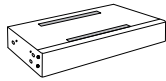

C x 1 pc



D x 1 pc

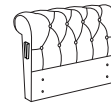

E x 1 pc

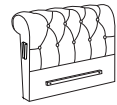

F x 2 pcs



G x 2 pcs



H x 2 pcs

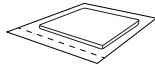

J x 3 pcs

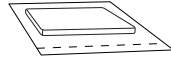

K x 1 pc



M x 2 pcs



N x 12 pcs







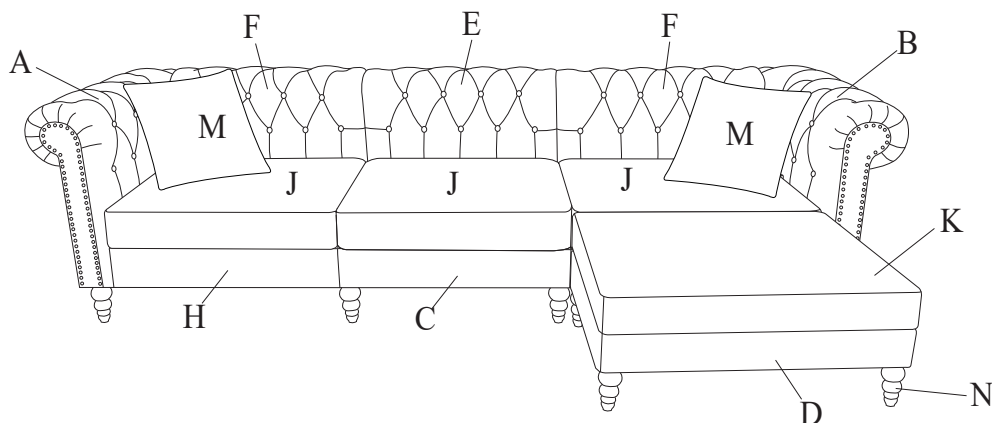



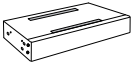



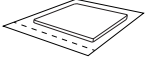

Please read over the instructions, it will be a time-saver in the long run.

Note: Before assembly, please be sure to work on a soft flat surface to avoid any damage to the finish.

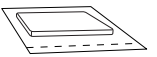

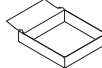

Please leave bolts loosened until all bolts are placed before tightening completely.

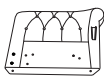

PACK LIST CARTON A:

Part#	Picture	Description	QTY	Part#	Picture	Description	QTY
C		Middle Seat Frame	1	①		Plastic Washer	12
D		Ottoman Seat Frame	1	②		Support Bar	8
E		Backrest	1	③		Bolt (M8*40MM)	2
G		Seat Panel	2	④		Flat Washer	4
J		Seat Cushion Package	3	⑤		Spring Washer	4
K		Ottoman Seat Cushion Package	1	⑥		Allen Wrench	1
O		Rkny	4	⑦		Bolt (M8*70MM)	2
N		Leg	12	K-Cover		PU Fabric Cover	1
J-Cover		PU Fabric Cover	3				

PACK LIST CARTON B:

Part#	Picture	Description	QTY	Part#	Picture	Description	QTY
A		Left Armrest	1	F		Middle Seat Backrest	2
B		Right Armrest	1	H		Front Rail	2

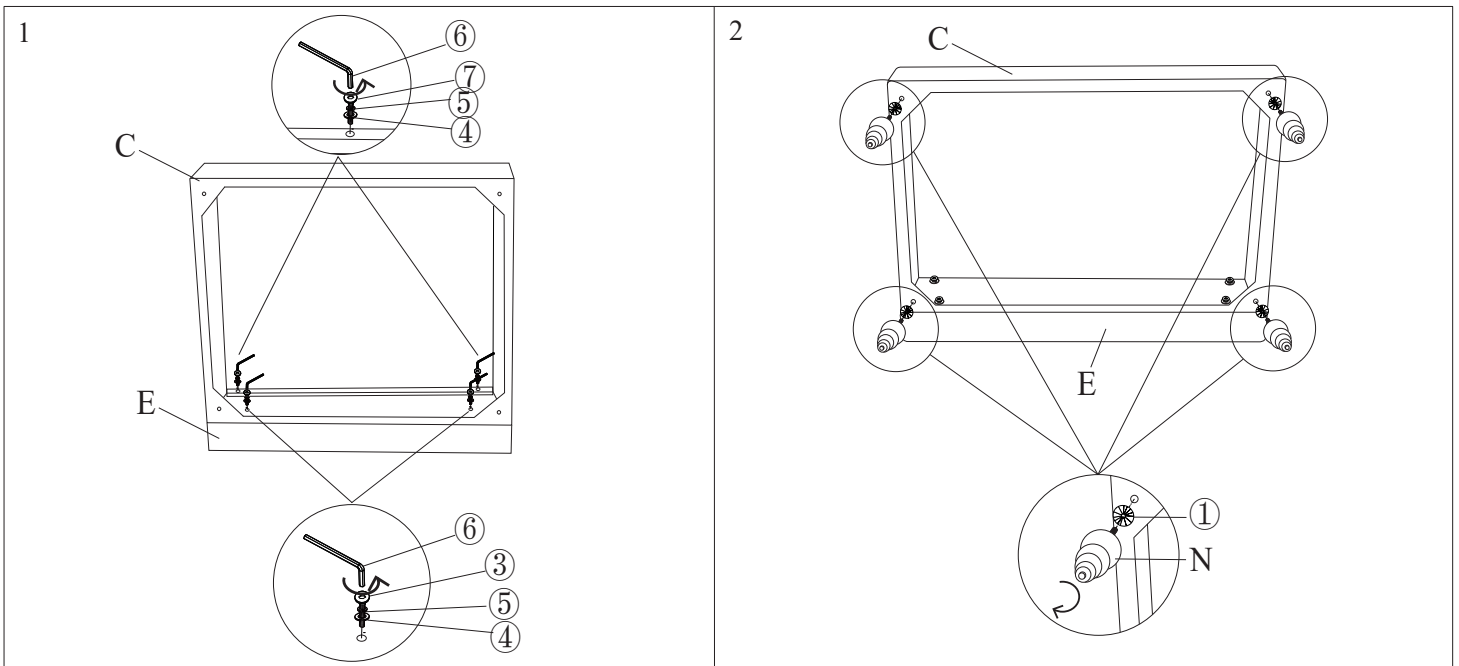

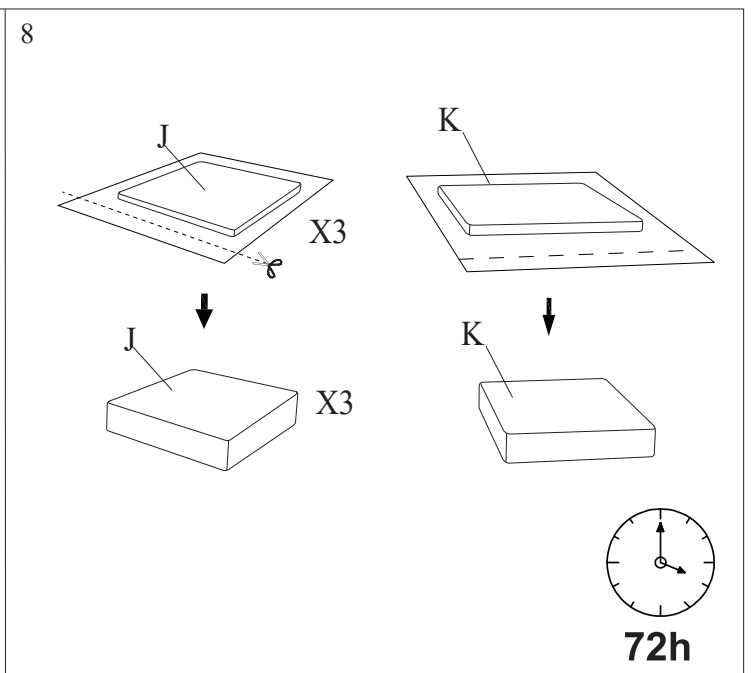
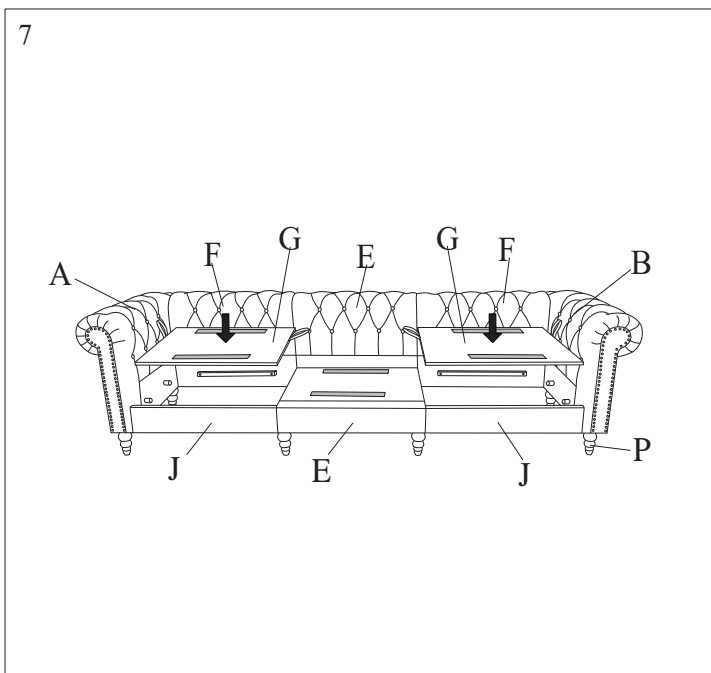
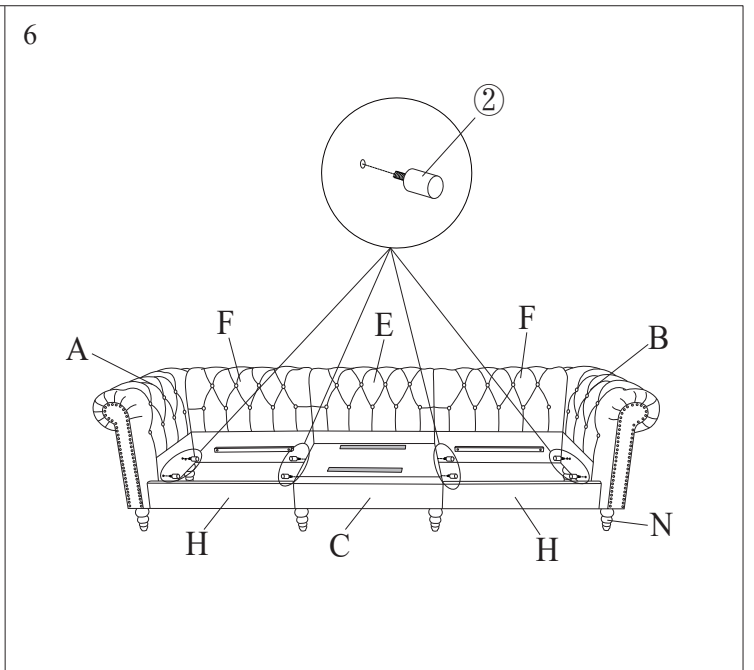
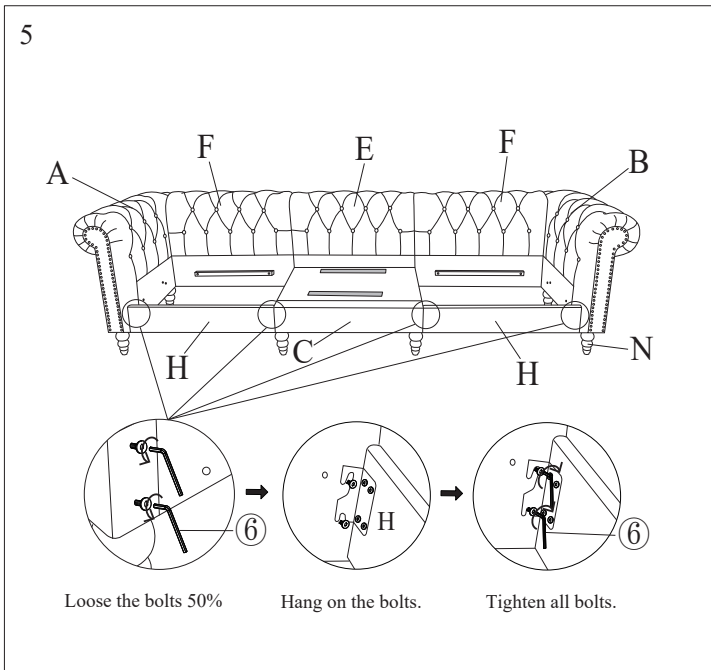
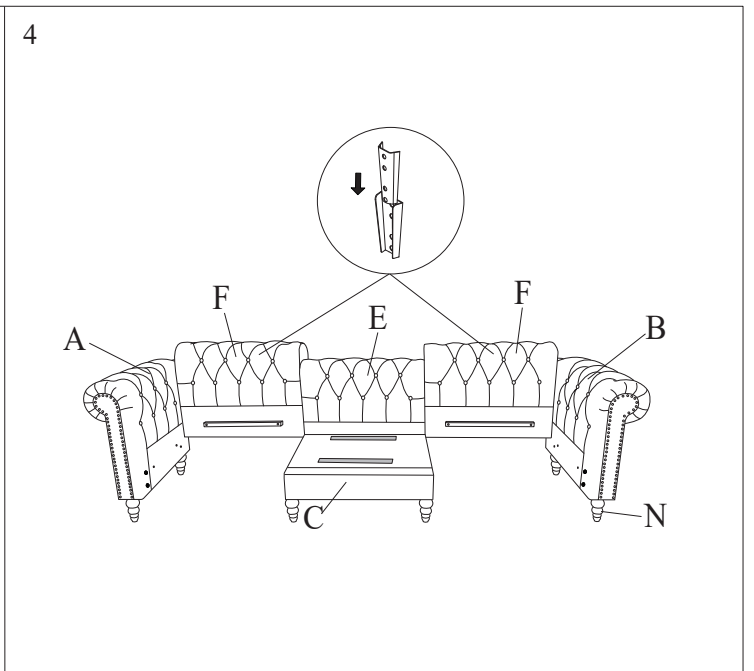
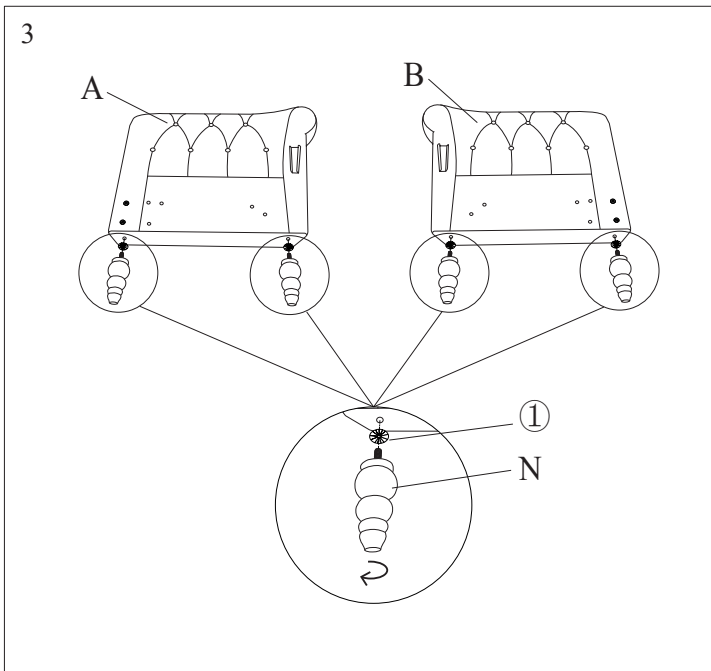

9

X 3

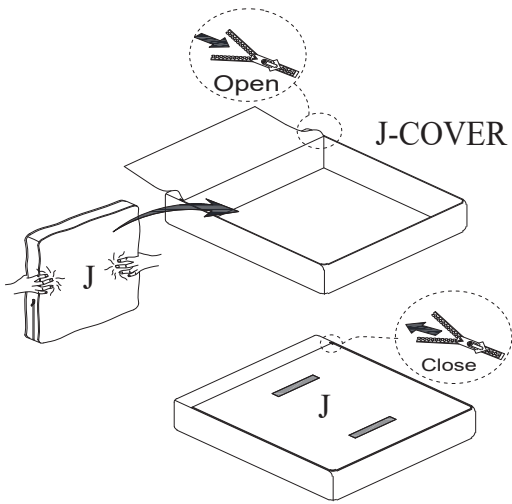

10

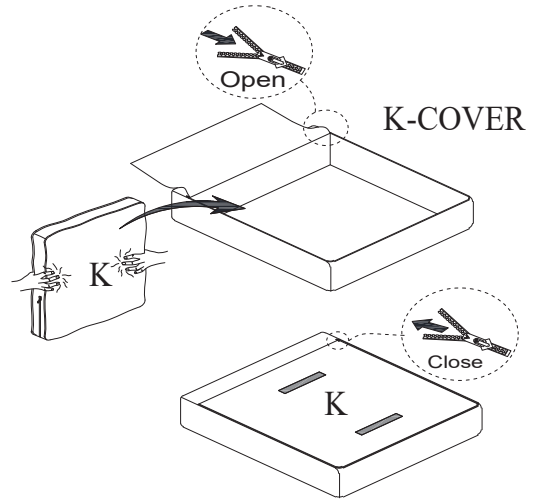

NOTE:

If you purchase the sofa made of fabric material, after completing STEP 8, proceed to STEP 11.

If you purchase the sofa made of PU material, after completing STEP 8, proceed to STEP 9-10, then to STEP 11.

11

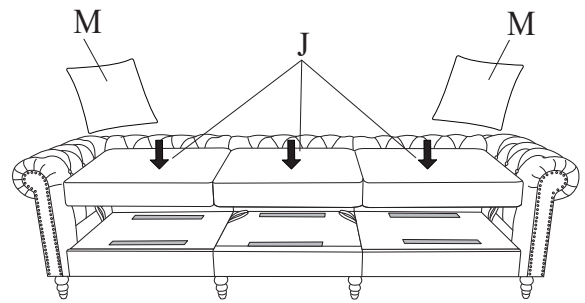

12

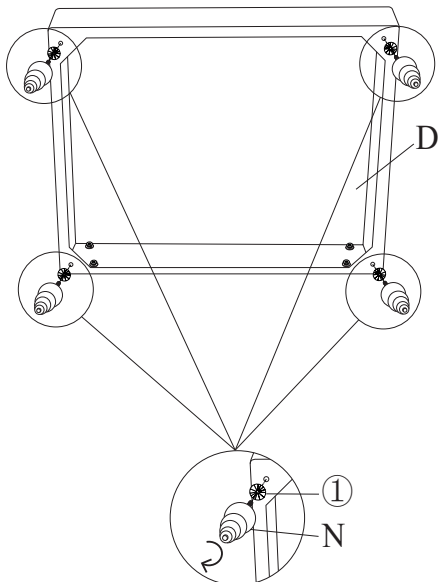

13

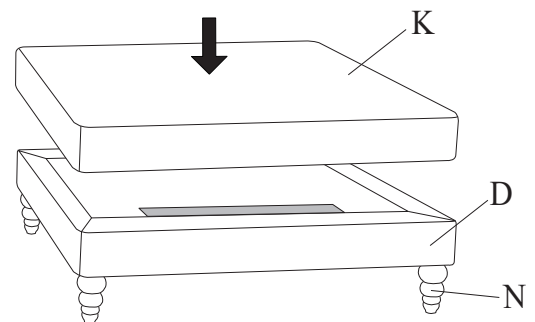

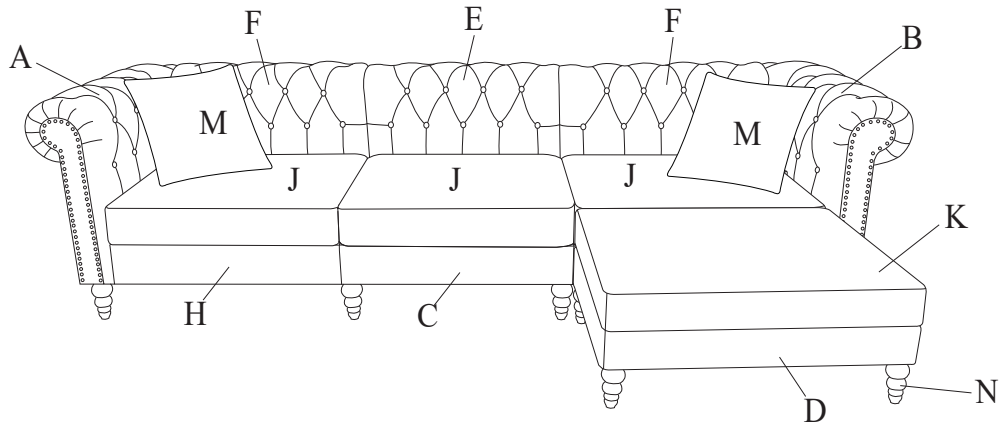

5-5