

## HARDWARE LIST

- A (4) Allen Bolts 1/4" x 3"
- B (4) Allen Bolts 1/4" x 2 3/8"
- C (4) Lock Washers 1/4"
- D (6) Wood Screws 35mm
- E (12) Wood Pins 50mm
- F (1) Allen Wrench 4mm

## PARTS LIST

- G (1) Back Panel
- H (2) Side Panels
- J (2) Mattress Rails
- K (1) Mattress Slats

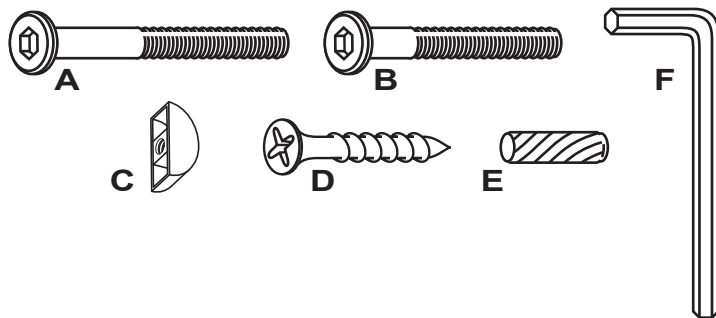

### STEP 1

Begin assembly by attaching ONE Side Panel (H) to the Back Panel (G) by inserting each Wood Dowel (E) and aligning with the open holes to set in place. Once in place, secure from the outside using 2 Allen Bolts (B) per each side. Place Lock Washer (C) into the hole at the side with the curved side in. Tighten all bolts using the Allen Wrench (F) that has been provided.

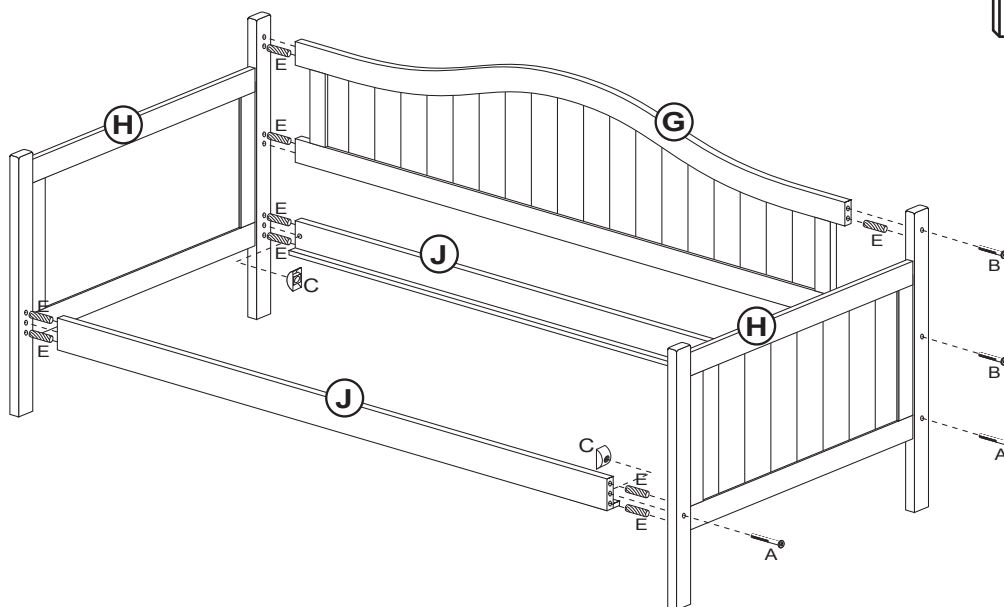

### STEP 2

Next attach both Mattress Rails (J) to the SAME Side Panel (H) using 2 Allen Bolts (A) from the outside to secure in place. Tighten all bolts.

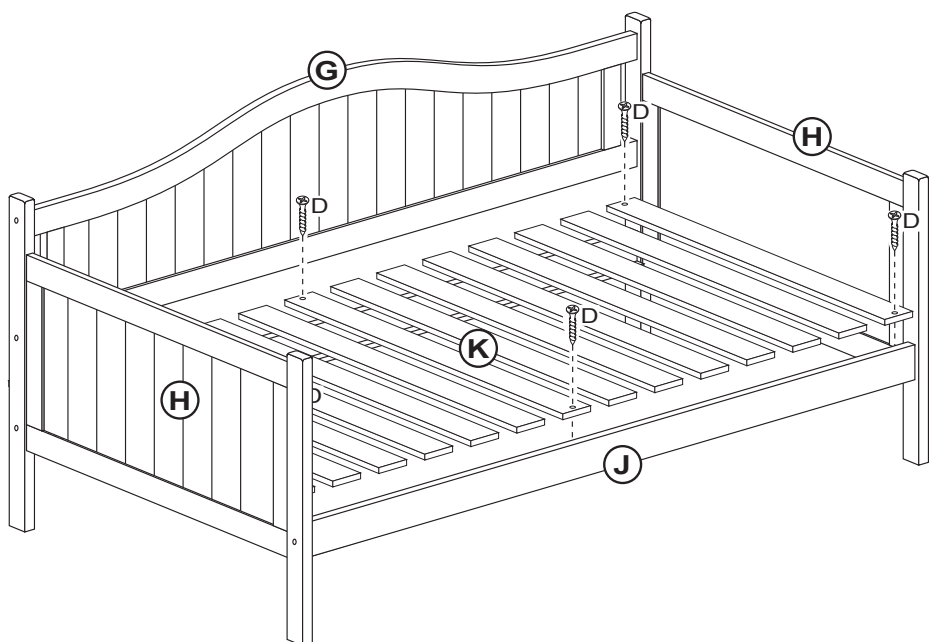

### STEP 3

Repeat Steps 1 and 2 to assemble the REMAINING Side Panel (H) to the components illustrated above.

### STEP 4

Attach the Mattress Slats (K) to the inside of each Mattress Rail (J) by unrolling the slats and setting in place. Once in place secure to the support bar with 6 Wood Screws (D) to secure in place. See next page for Trundle assembly instructions.

**HARDWARE LIST**

- A (8) Allen Bolts  $\frac{1}{4}$ " x  $2 \frac{3}{8}$ "  
 B (4) Screws  $\frac{1}{4}$  x  $1 \frac{1}{4}$ "  
 C (8) Screws 35mm  
 D (4) Wood Knobs  
 E (6) Metal Casters  
 F (1) Allen Wrench 4mm  
 G (24) Allen Bolts  $\frac{1}{4}$ " x 2"

**PARTS LIST**

- H (1) Front Panel  
 J (2) Side Panels  
 K (1) Rear Panel  
 L (6) Wheel Blocks  
 M (2) Slat Sets

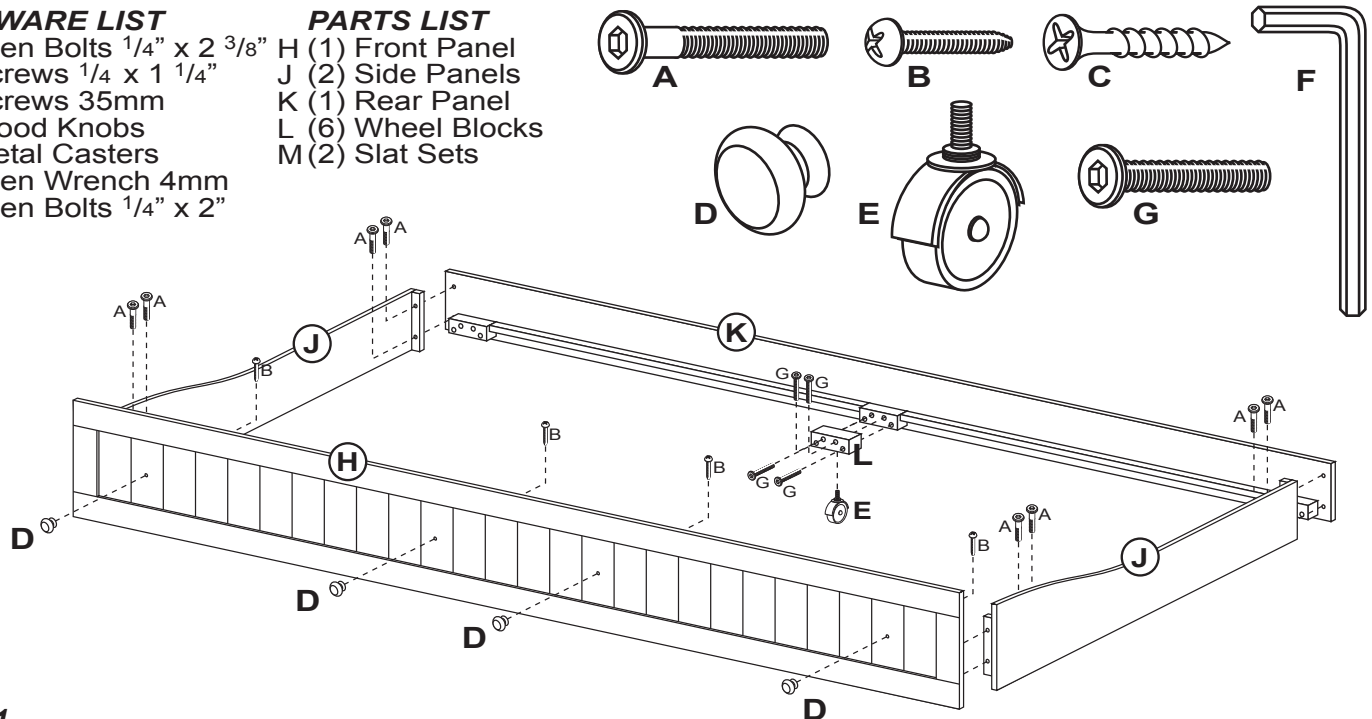
**STEP 1**

Attach each Wood Knob (D) to the Front Panel (H) by aligning holes and securing from the backside with 1 Screw (B) per each.

**STEP 2**

To assemble the Trundle, attach each Trundle Side Panel (J) to the inside of the Front Panel (H) by aligning holes and securing with 2 Allen Bolts (A) per each corner. Tighten all bolts using the Allen Wrench (F) that has been provided.

**STEP 3**

Next attach the Trundle Back Panel (K) to each Trundle Side Panel (J) by aligning the holes and securing with 2 Allen Bolts (A) per each corner. Tighten all bolts.

**STEP 4**

Attach each Wheel Block (L) to the inside of each Front & Rear Panels (H & K) by aligning each in place and securing with 4 Allen Bolts (G). Tighten all bolts. Attach each Metal Caster (E) to the bottom of each block by screwing in place.

**STEP 5**

Finally attach the Slat Sets (M) to the inside of the Trundle unit (now assembled) using 8 Wood Screws (C) to secure in place. Tighten all screws. The assembly is now complete.

