

ASSEMBLY INSTRUCTIONS

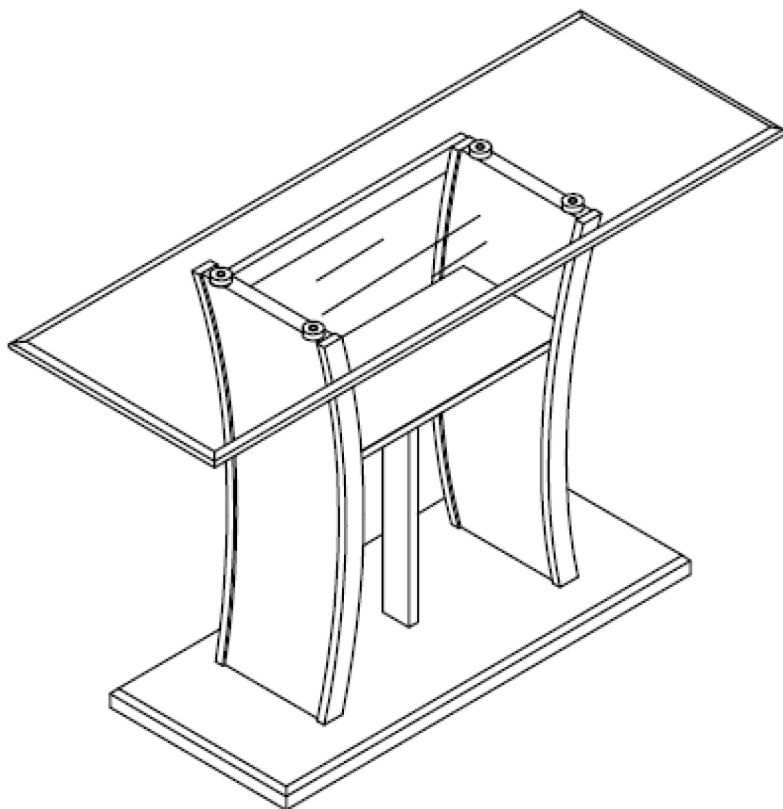

TOOLS REQUIRED

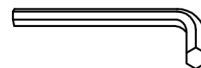

Allen Wrench

(Included)



2 - Persons
Recommended

ASSEMBLY RATING



EASY —————> DIFFICULT

The Assembly Rating is a 5-point system showing the level of effort needed to assemble a specific product.



CHECK BEFORE STARTING

Are you missing anything?

Double-check all parts, hardware and accessories listed on Page 6 are accounted for.

Check out our Quick Tips!

We recommend reviewing the pre-assembly handouts. Even experts need a refresher now and then!

Should we send any replacements?

Are there any irregularities or flaws in the parts? We can send replacements!

Prep Time!

Please review the assembly instructions and all diagrams prior to assembling. Set up your workspace by laying the parts and hardware out separately, then begin!

PRE ASSEMBLY INTRODUCTION

We understand building ready-to-assemble furniture can be a challenging experience for some. To help avoid confusion, we have provided some helpful tips that may speed up the process.

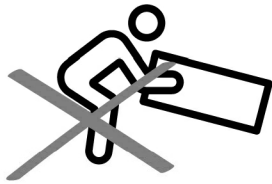

Teamwork

ALWAYS have at least two people to help with transporting and assembling the product to avoid potential injury and/or damage.

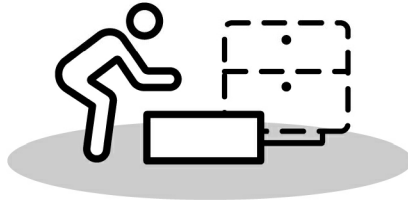
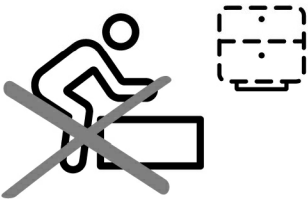

Suitable Location

Assembling near the area of the intended location is highly recommended.



Sufficient Space

Make sure you have enough space to move around during the assembly.

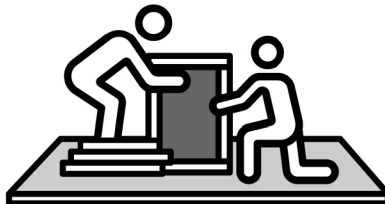

Avoid Scratches

Use cardboard, blankets or a carpeted area while assembling furniture to prevent scratches.

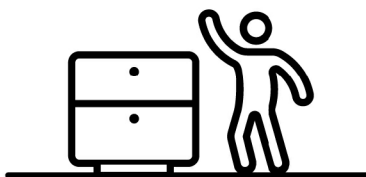
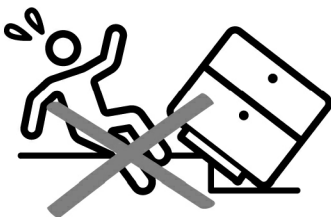

Flat Surface

Make sure the furniture rests on a flat and level surface with each leg evenly touching the floor.

ASSEMBLY AND CARE ADVICE



FAILURE TO FOLLOW THE GUIDELINES BELOW MAY RESULT IN INJURY AND/OR PROPERTY DAMAGE.



Position each part correctly and insert screws or bolts into their respective holes.



Turn clockwise to tighten and only tighten when step is completed or when instructed to do so.



Use the appropriate hand tools or power tools for assembly. Select steps, such as tightening screws and/or bolts, may require hand tools to avoid causing damage during assembly.



Save the instructions and store any supplied tools for later maintenance.



After two weeks, check and tighten any loose hardware and repeat again every six months thereafter.

IT IS THE USER'S RESPONSIBILITY TO MAINTAIN THE FURNITURE. THE HARDWARE MAY LOOSEN OVER TIME AND MAY CAUSE THE FURNITURE TO BE WOBBLY AND UNABLE TO SUPPORT ITS INTENDED WEIGHT CAPACITY. THIS MAY LEAD TO COLLAPSE AND MAY CAUSE SERIOUS INJURY.

BUFFET



- Please keep instructions for future reference.
- Check the quantity and irregularity of parts and hardware before you start.

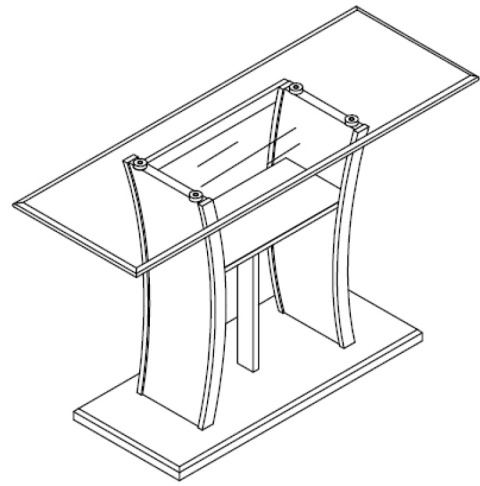

PARTS

#1 1pc

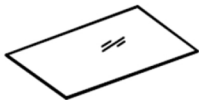

Glass Top

#2 1pc



Shelf

#3 2 pcs



Stand

#4 1pc

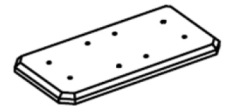

Base

#5 1pc

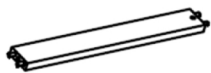

Center Support Stand

#6 1pc



Stand Support A

#7 1pc



Stand Support B

HARDWARE

#A 10pcs



Bolt 1/4"×3/4"

#B 10pcs



Lock Washer 1/4"

#C 10pcs



Flat Washer 1/4"

#D 1pc



Allen Wrench M4

#E 5pcs



L-Bracket

#F 4pcs



Threaded Stud

#G 5pcs



Bolt 5/16"×2"

#H 9pcs



Lock Washer 5/16"

#I 9pcs



Flat Washer 5/16"

#J 1pc



Allen Wrench M5

#K 4pcs



Spacer

#L 4pcs

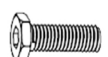

Bolt 5/16"×1-1/2"

ASSEMBLY INSTRUCTIONS

1

- Part #2 x1pc
- Part #5 x1pc
- Hardware #A x2pcs
- Hardware #B x2pcs
- Hardware #C x2pcs
- Hardware #E x1pc

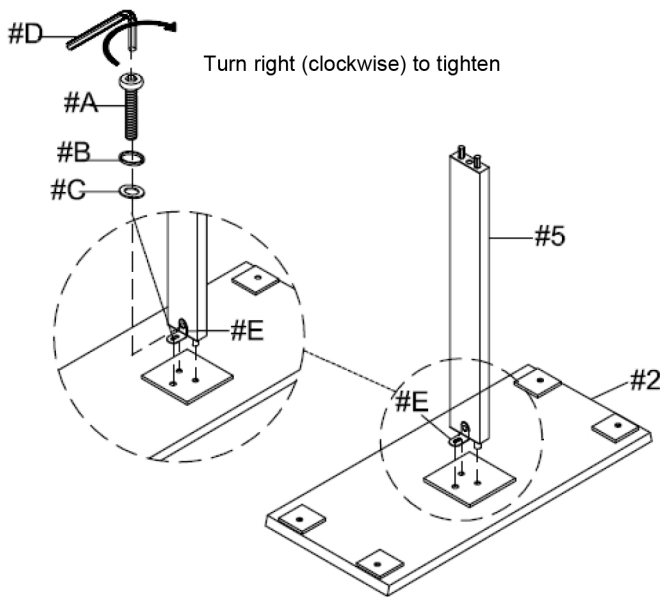

- I. Prepare 2 bolt assemblies by inserting FIRST the lock washer (#B) onto the bolt (#A) and then the flat washer (#C) onto the SAME bolt (#A), in that order.
- II. Align the short side of the L-bracket (#E) with the pre-drilled hole on the center support stand (#5). Insert one bolt assembly through the short side of the L-bracket (#E) and secure that bolt using the Allen wrench (#D) to lock it with the center support stand (#5).
- III. Insert the center support stand (#5) with the long side of the L-bracket (#E) into the bottom of the shelf (#2).
- IV. Insert the other bolt assembly through the long side of the L-bracket (#E) and secure that bolt using the Allen wrench (#D) to lock it with the shelf (#2).

2

- Part #3 x2pcs
- Hardware #A x8pcs
- Hardware #B x8pcs
- Hardware #C x8pcs
- Hardware #E x4pcs

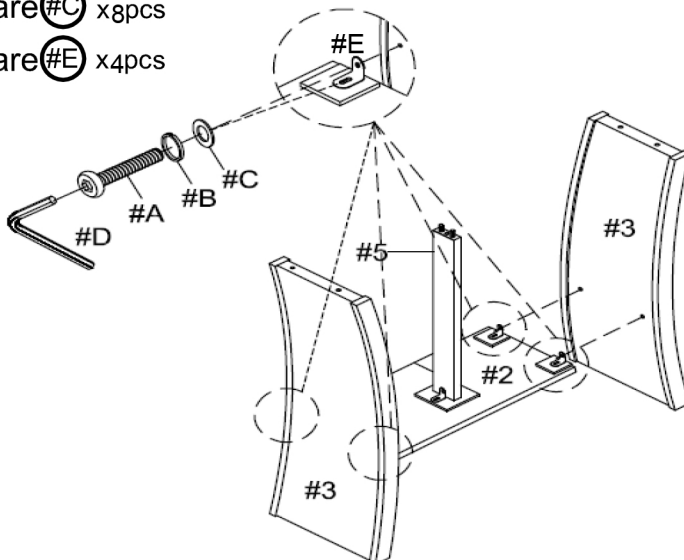

- I. Prepare 8 bolt assemblies by inserting FIRST the lock washer (#B) onto the bolt (#A) and then the flat washer (#C) onto the SAME bolt (#A), in that order.
- II. Align the long sides of the 4 L-brackets (#E) with the pre-drilled holes on the shelf (#2). Insert 4 bolt assemblies through the long sides of the L-brackets (#E) and secure those bolts using the Allen wrench (#D) to lock them with the shelf (#2).
- III. Align the two stands (#3) with the short sides of the 4 L-brackets (#E) assembled on the shelf (#2). Insert 4 bolt assemblies through the short sides of the L-brackets (#E) and secure those bolts using the Allen wrench (#D) to lock them with the stands (#3).

ASSEMBLY INSTRUCTIONS

3

Part (#4) x1pc

Hardware (#G) x5pcs

Hardware (#H) x5pcs

Hardware (#I) x5pcs

- I. Align the base (#4) with the pre-drilled holes on the stands (#3) and the center support stand (#5).
- II. Prepare 5 bolt assemblies by inserting FIRST the lock washer (#H) onto the bolt (#G) and then the flat washer (#I) onto the SAME bolt (#G), in that order.
- III. Insert the bolt assemblies through the base (#4) and secure those bolts using the Allen wrench (#J) to lock them with the stands (#3) and the center support stand (#5).

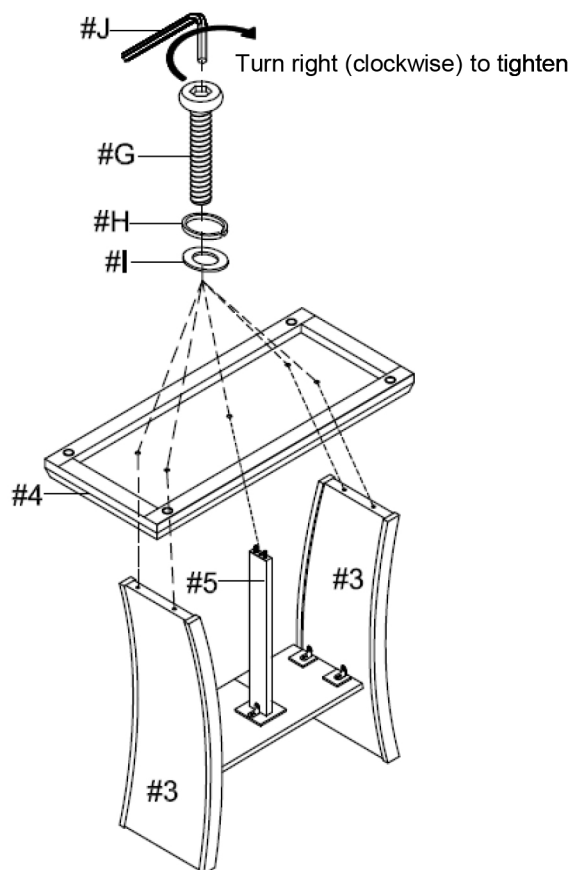

4

Part (#6) x1pc

Part (#7) x1pc

Hardware (#H) x4pcs

Hardware (#I) x4pcs

Hardware (#L) x4pcs

- I. Align the stand support A (#6) and the stand support B (#7) with the pre-drilled holes on the stands (#3).
- II. Prepare 4 bolt assemblies by inserting FIRST the lock washer (#H) onto the bolt (#L) and then the flat washer (#I) onto the SAME bolt (#L), in that order.
- III. Insert the bolt assemblies through the stand support A (#6) and the stand support B (#7) and secure those bolts using the Allen wrench (#J) to lock them with the stands (#3).

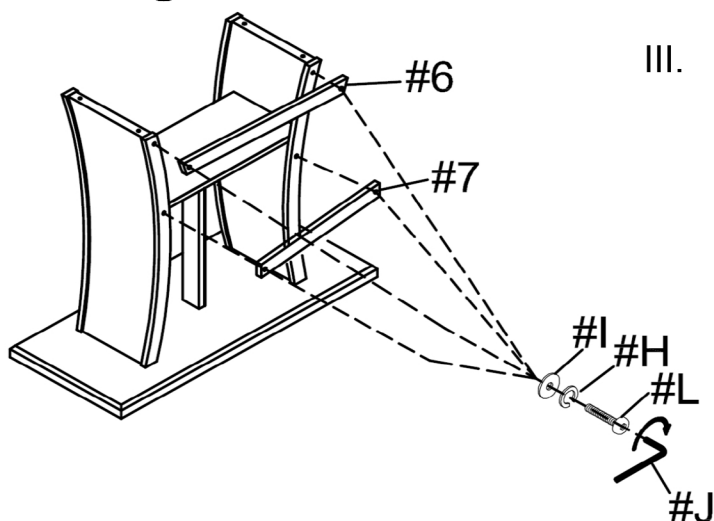

ASSEMBLY INSTRUCTIONS

5

Hardware  (#F) x4pcs

Hardware  (#K) x4pcs

Insert the 4 threaded studs (#F) into the top of the stands (#3). Then insert the 4 spacers (#K) onto the 4 threaded studs (#F).

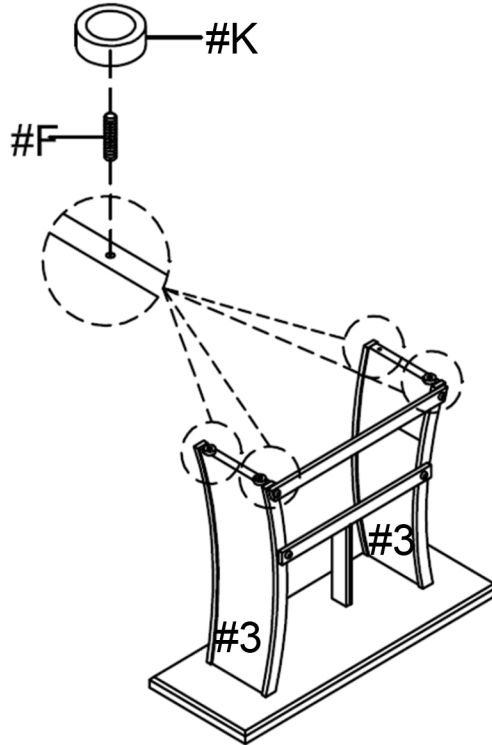

6

Part  (#1) x1pc

- I. With the help of another person, carefully place and center the glass top (#1) over the spacers (#K).
- II. Make sure the table is rested on a flat surface and does not feel loose or wobbly. If it does, double check that the bolts/screws are secured and properly tightened.

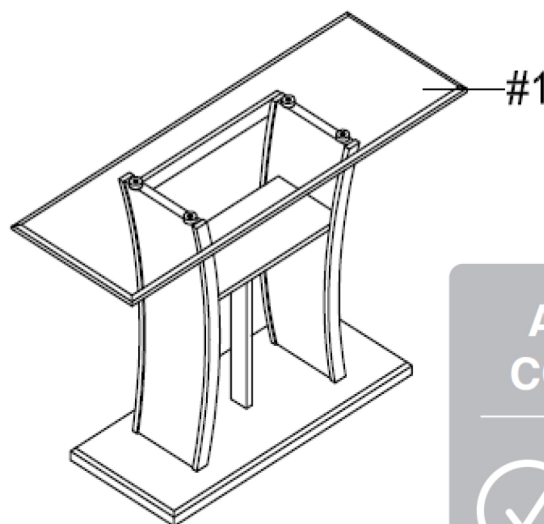

ASSEMBLY COMPLETED



Please ensure the furniture rests on an even and flat surface. If the product wobbles or feels loose, double-check all bolts and/or screws are properly tightened and secured.



Keep this handy!

Please retain this instruction manual and any order-related information for future reference.