

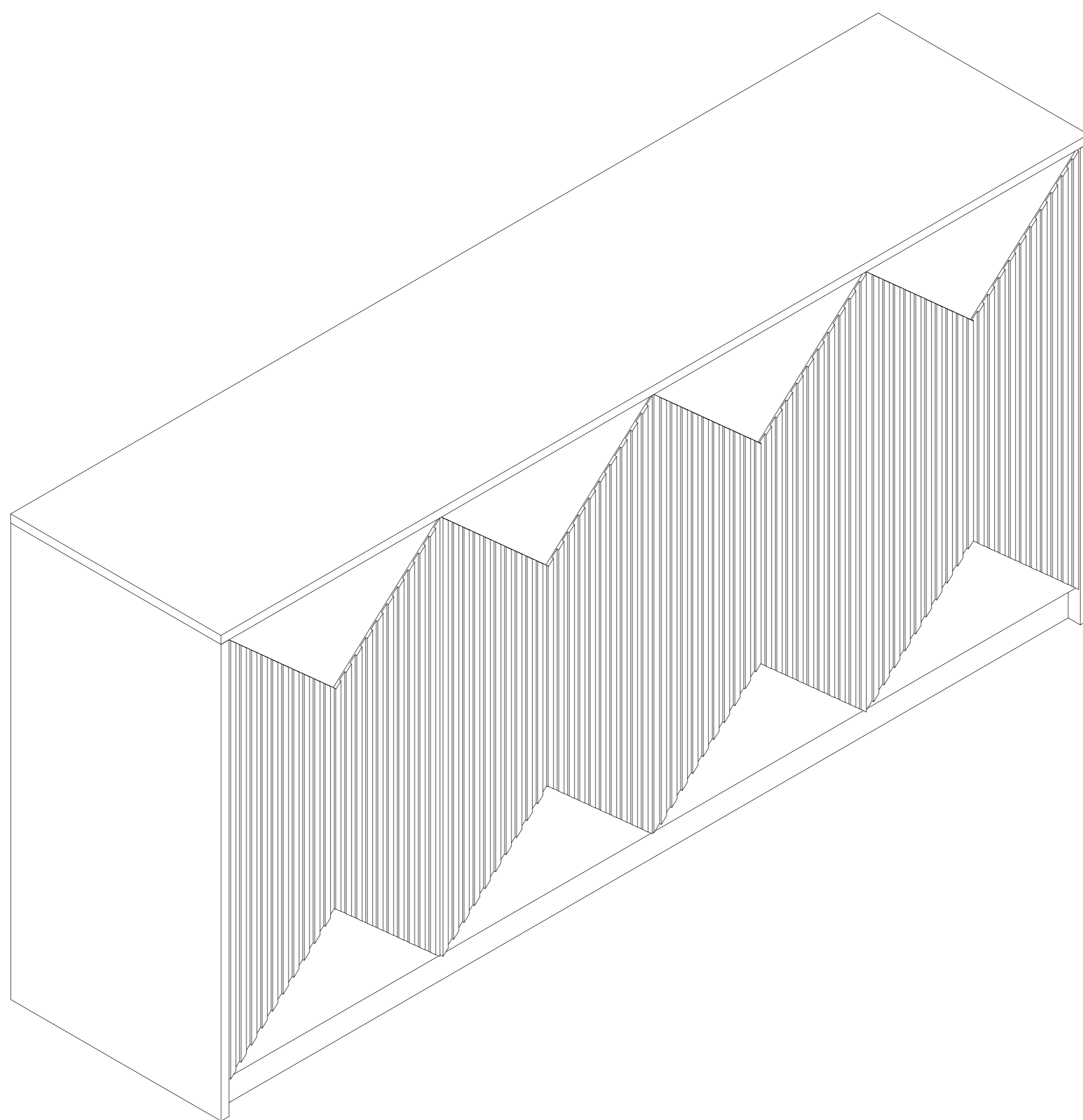

USER MANUAL

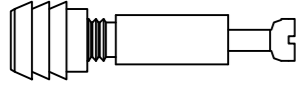

Thank you for choosing our products! To ensure a smooth and safe installation, please carefully read this manual and follow the instructions. For the video installation instructions, please refer to the product page.

- Before installation, please check the product list to make sure you have received all parts.
- During the installation, please operate carefully to avoid injury. Pay special attention to safety when carrying heavy objects or operating sharp tools.
- Please follow the steps in order. Do not skip any steps.
- If you encounter any problems during the installation process, please stop the operation immediately and contact our customer service team for help.
- Periodically check to ensure that all connectors (bolts, screws, etc.) are tight.

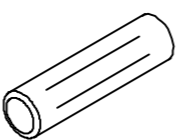
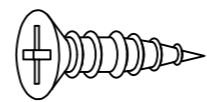
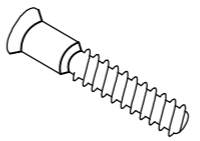
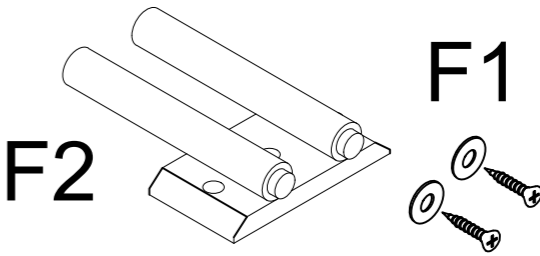
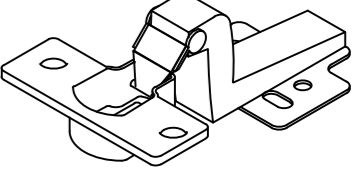
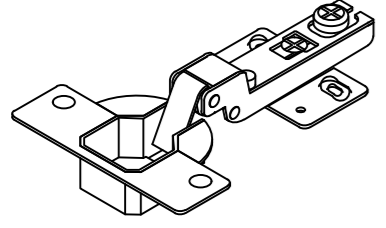
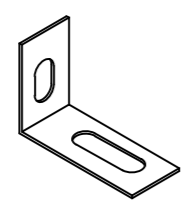
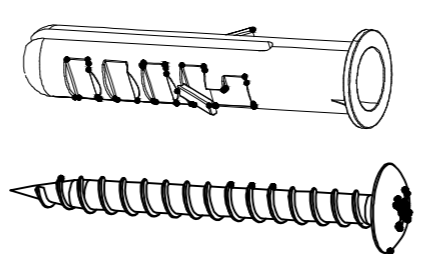
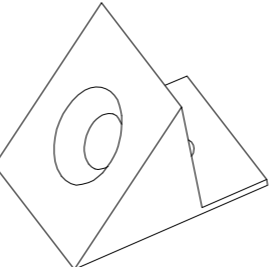
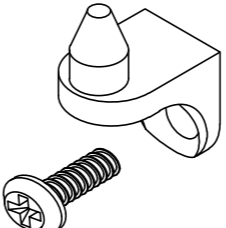
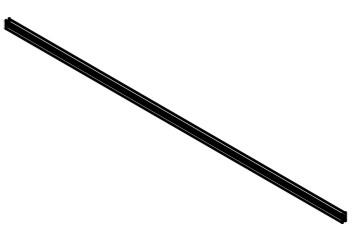
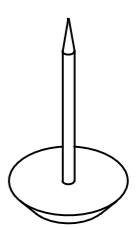
A 56+3	B 56+3	C 12+1	D 72+3	E 2	F 2	G 4
						
Ø6*35mm	Ø15*11.5mm	Ø8*30mm	M3.5*14mm	Ø6*38mm	F1 F2	
H 4	I 2	J 2	K 16	L 8	M 2	N 8+1
						
					708mm	

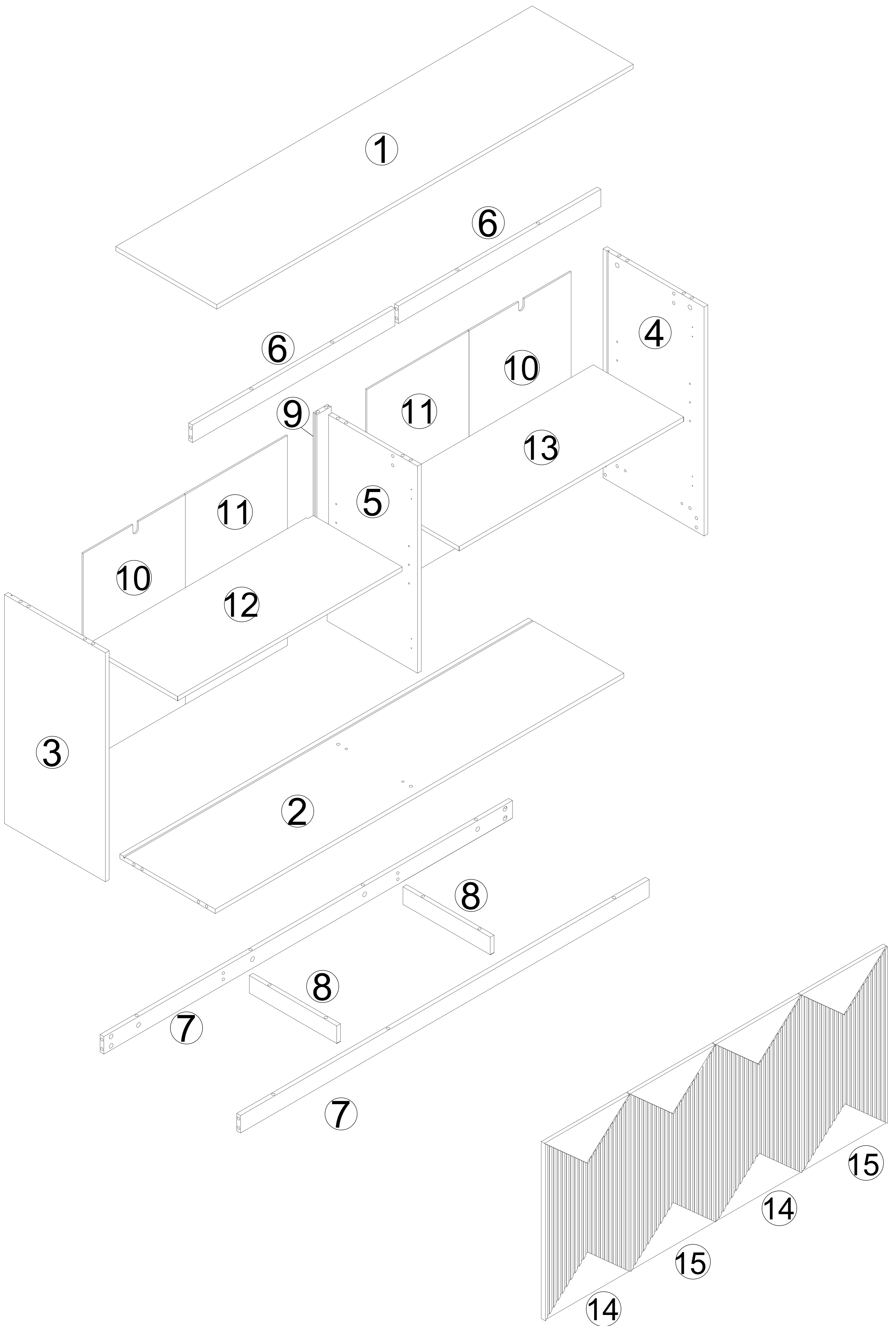

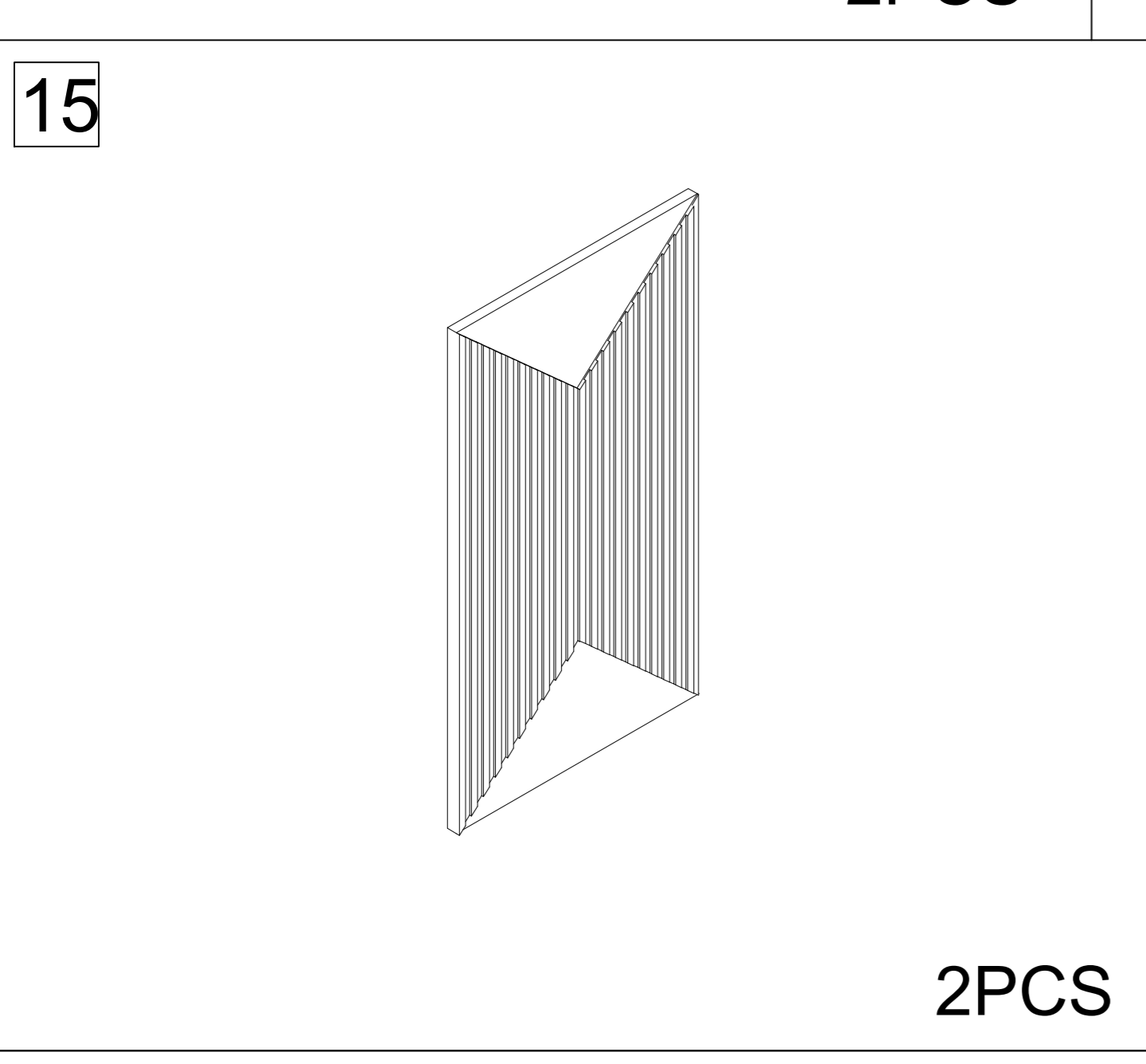
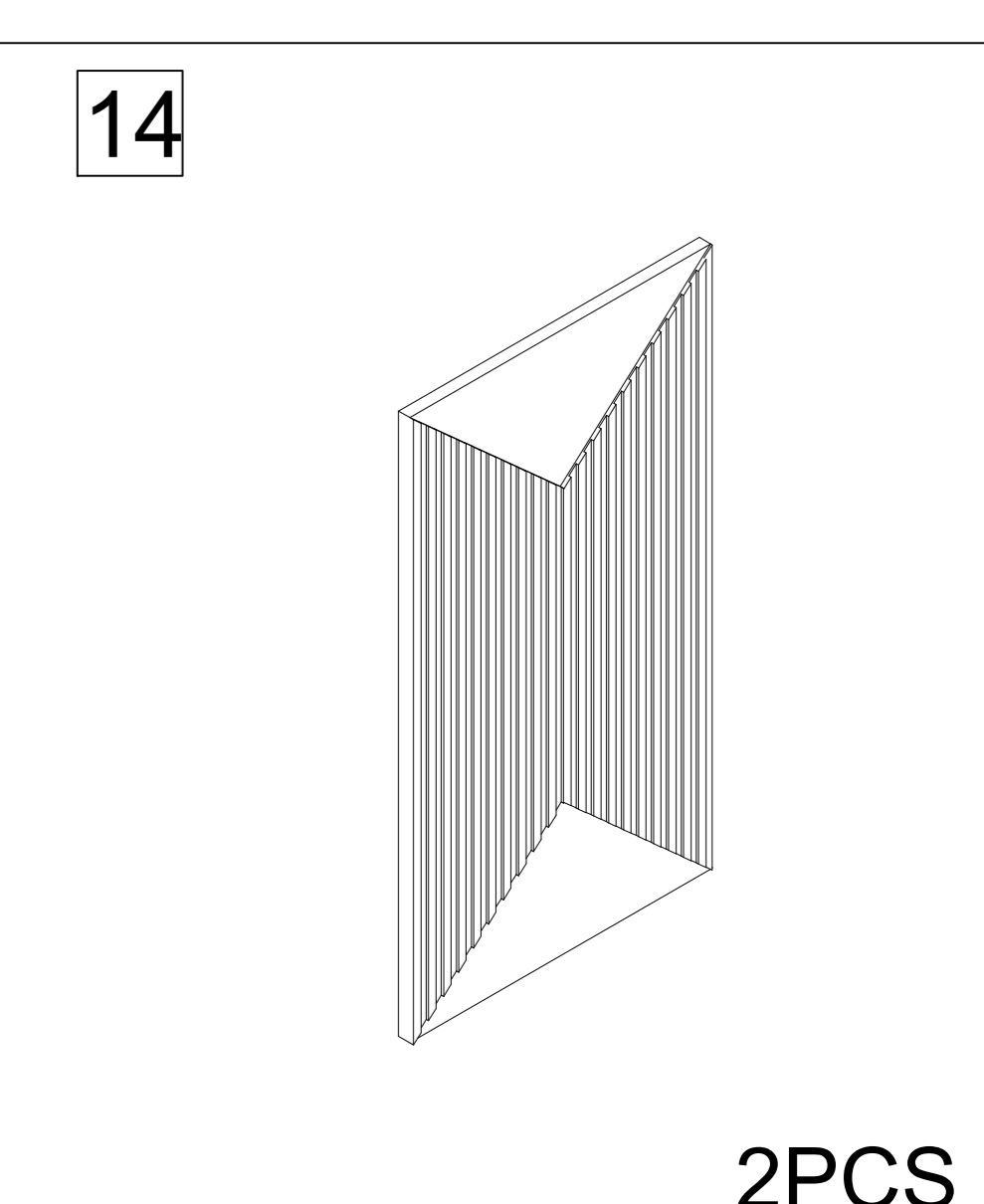
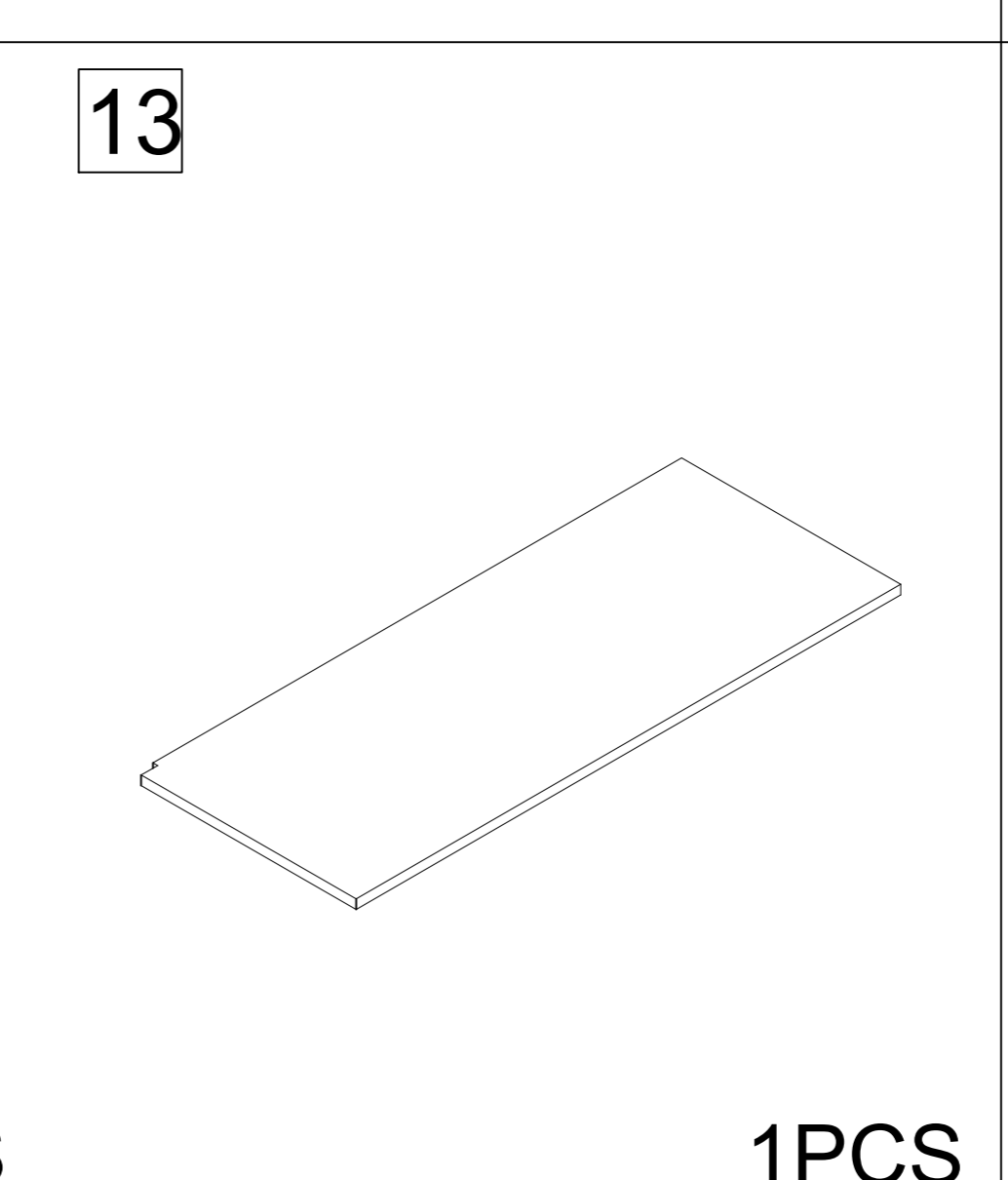
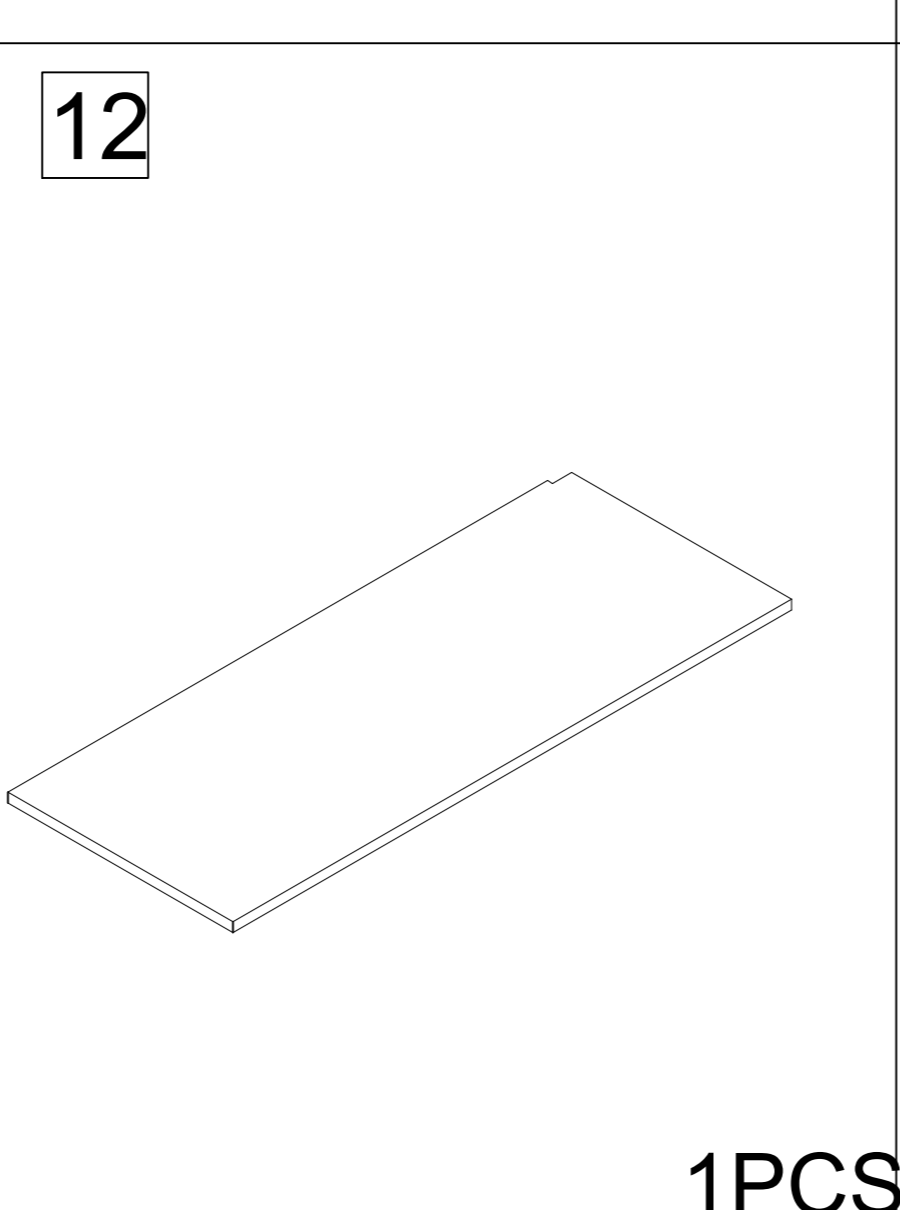
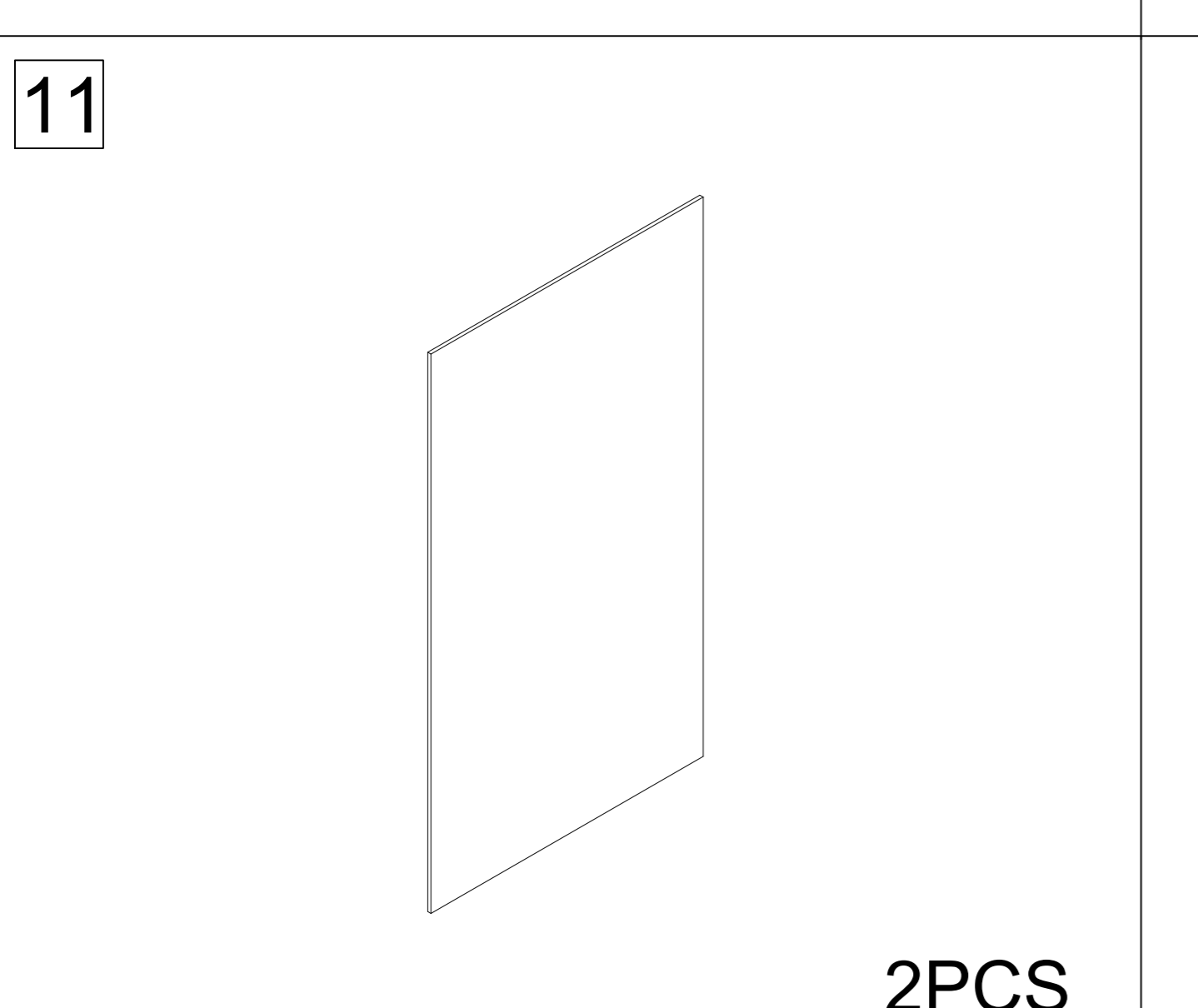
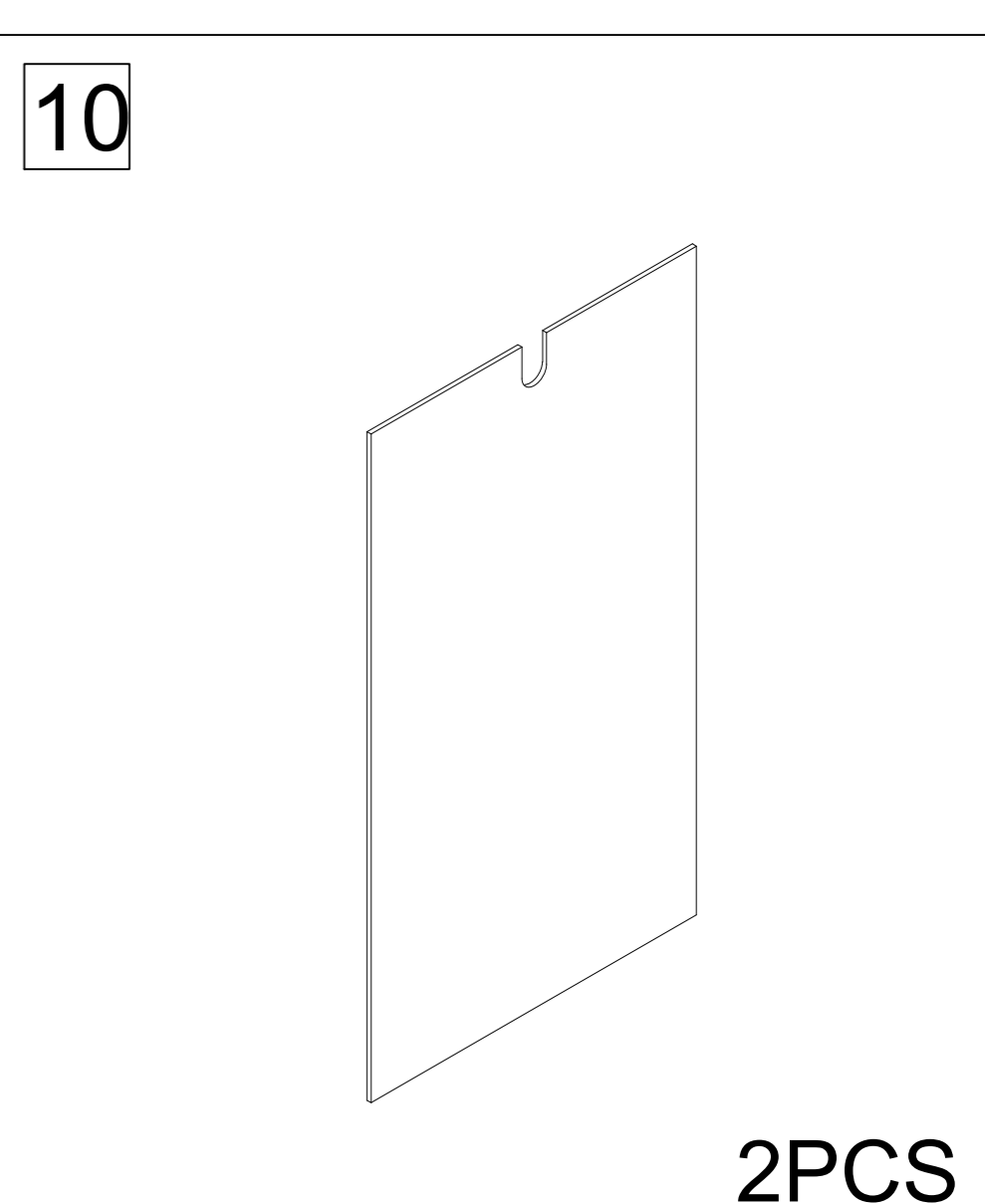
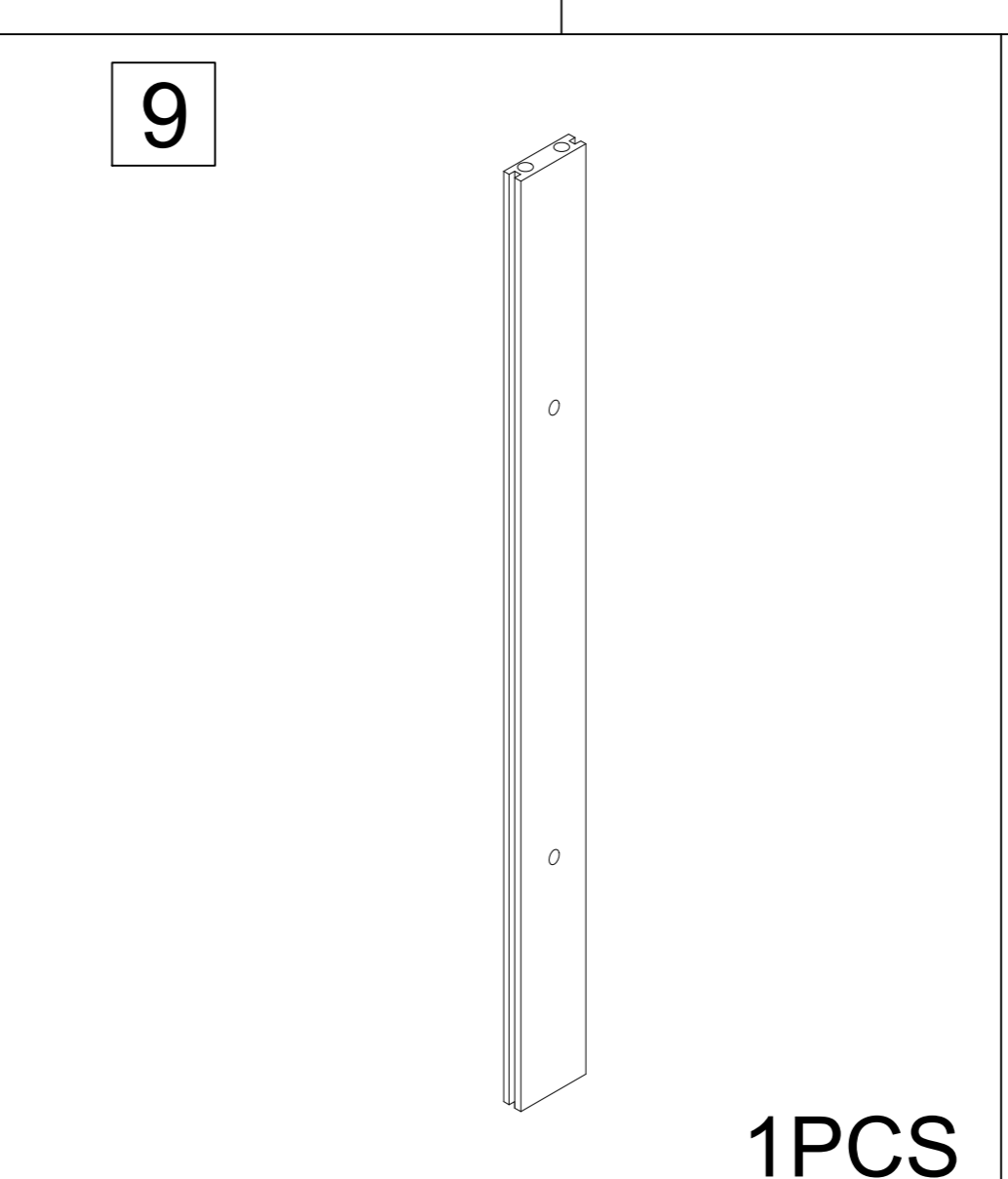
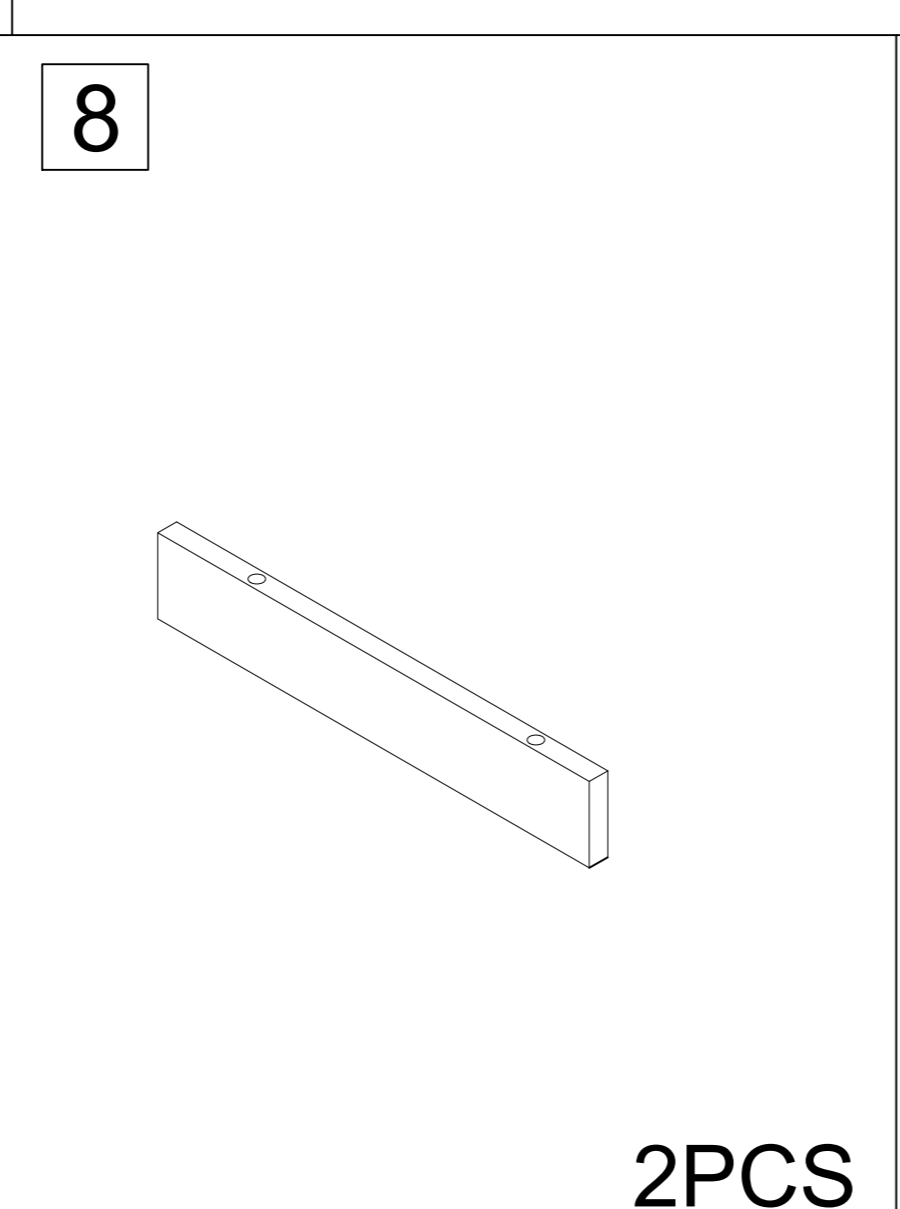
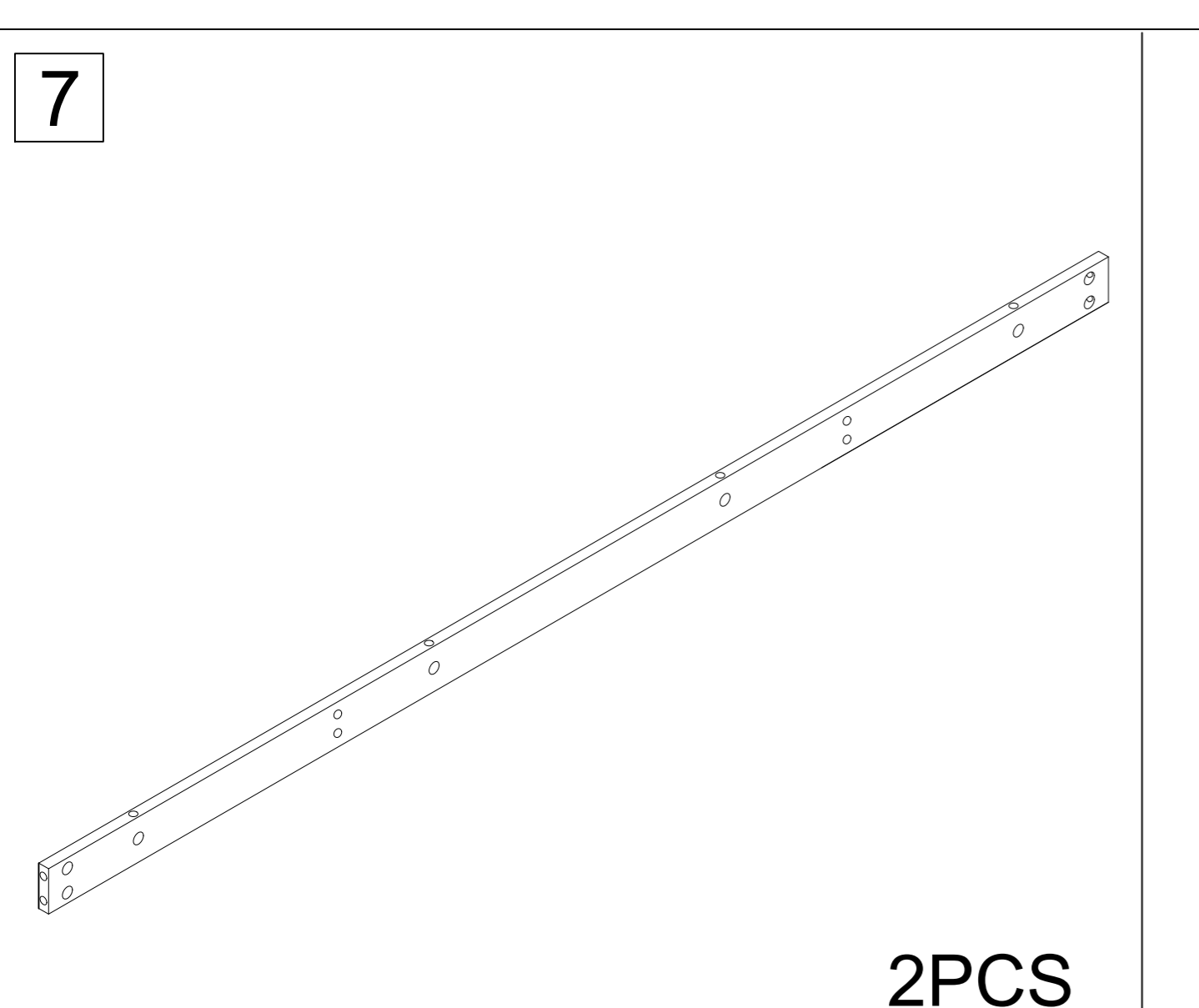
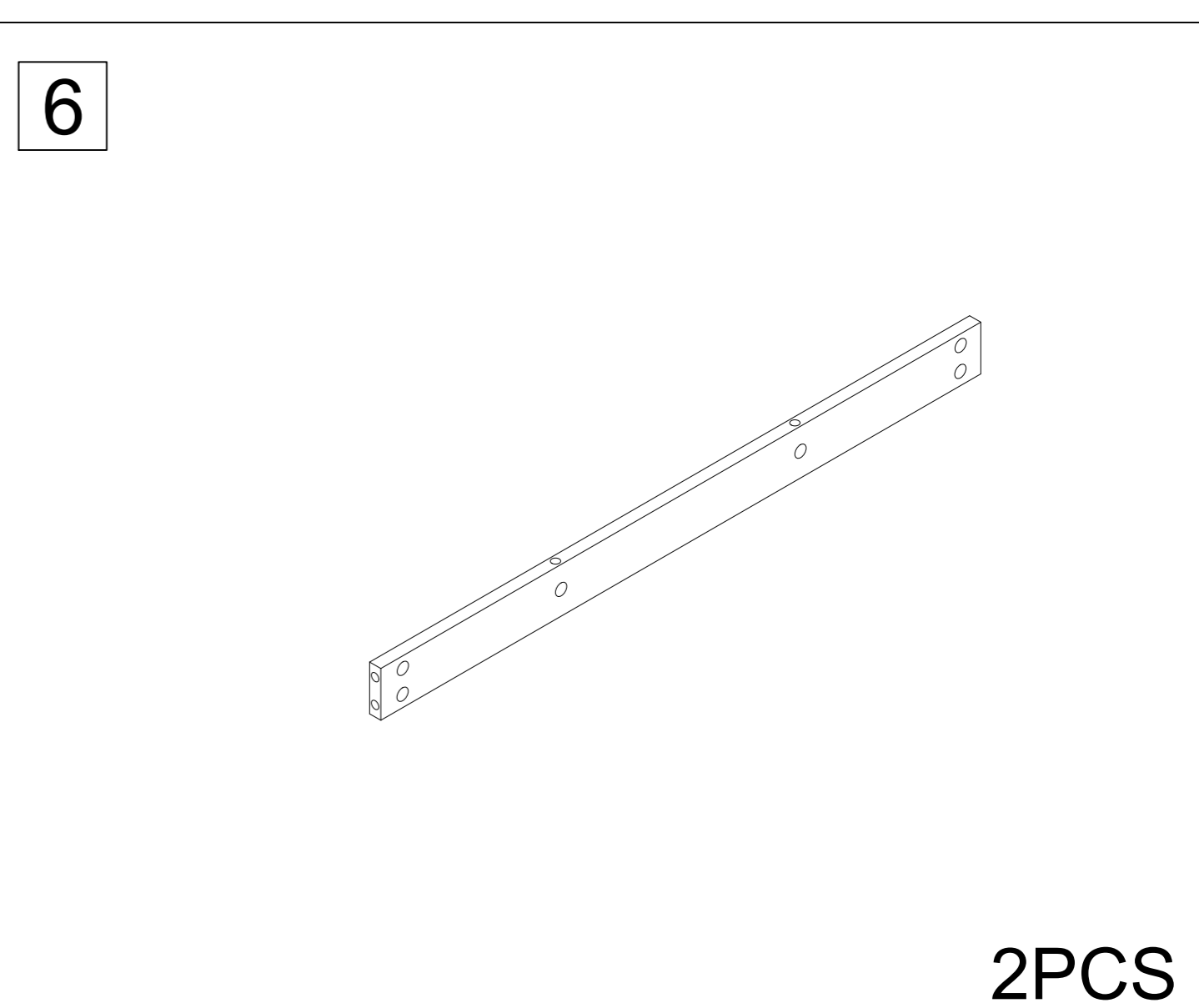
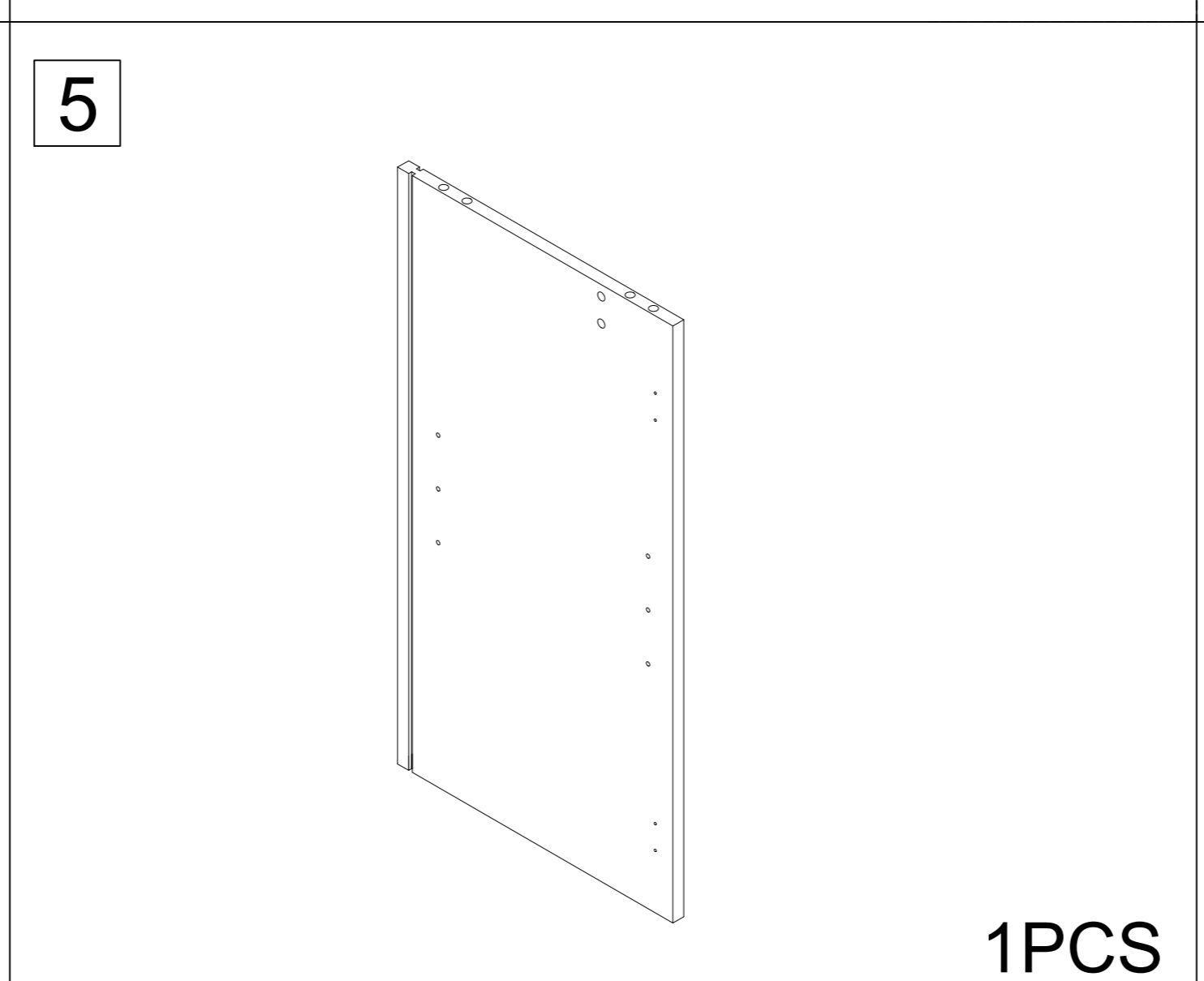
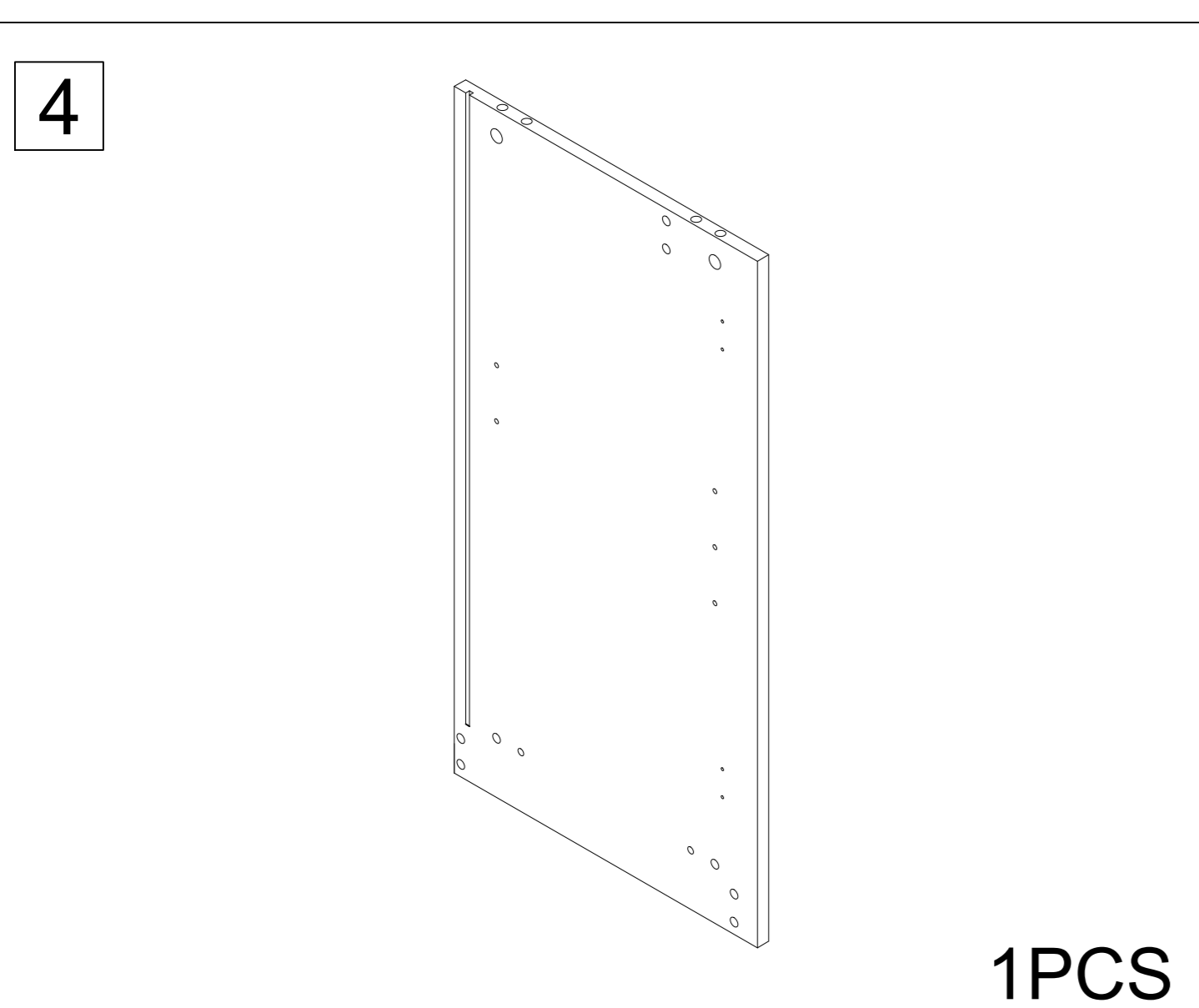
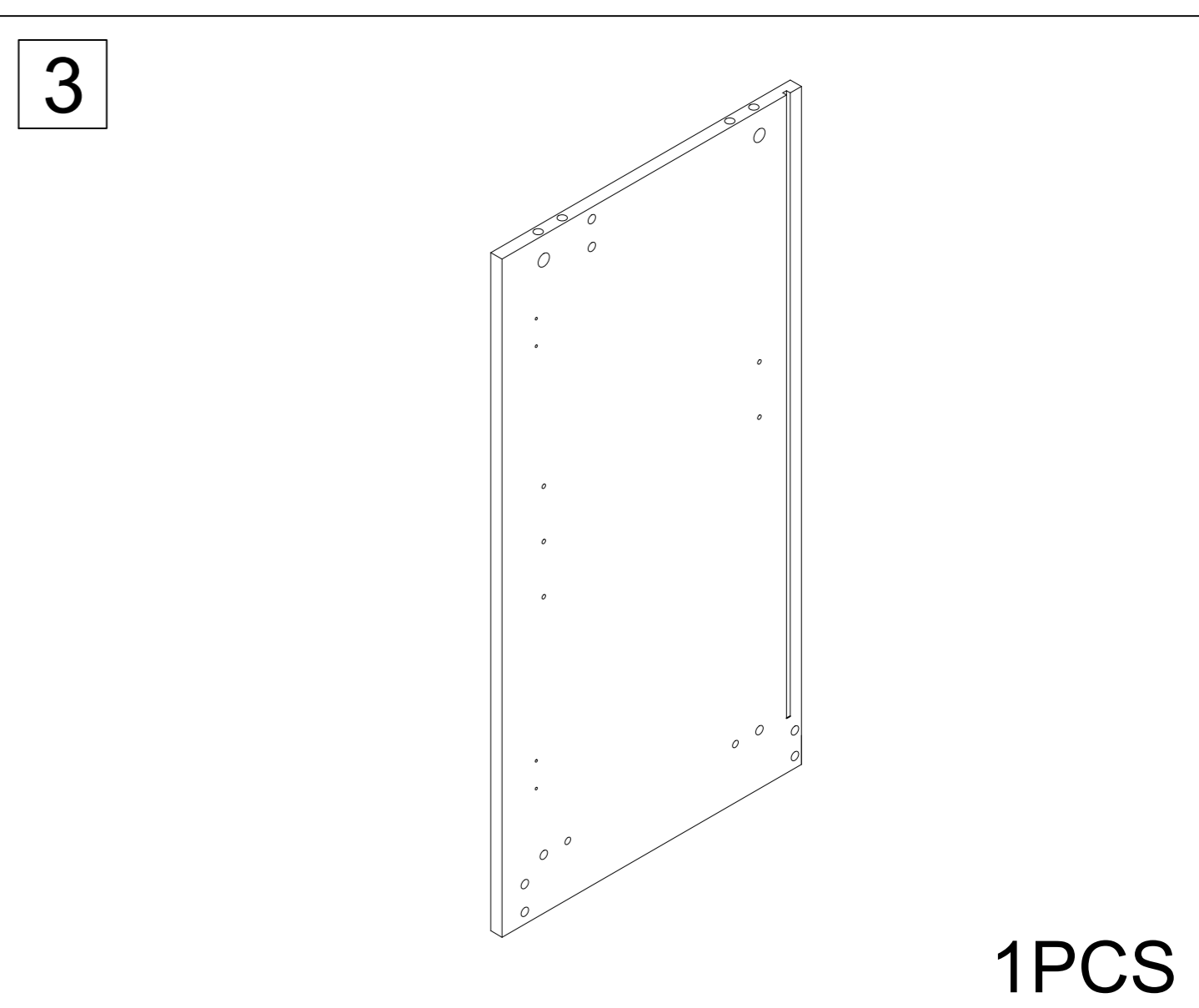
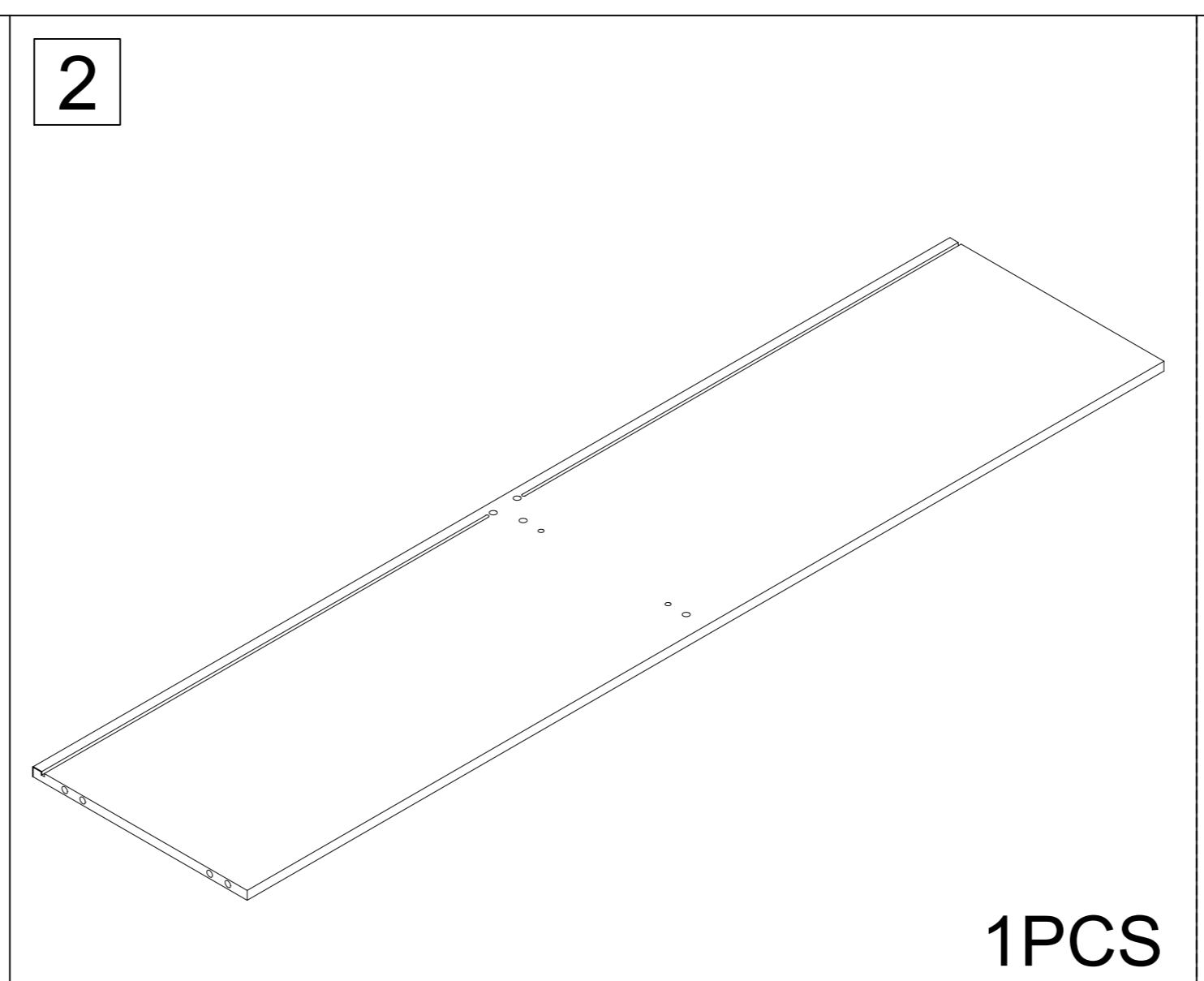
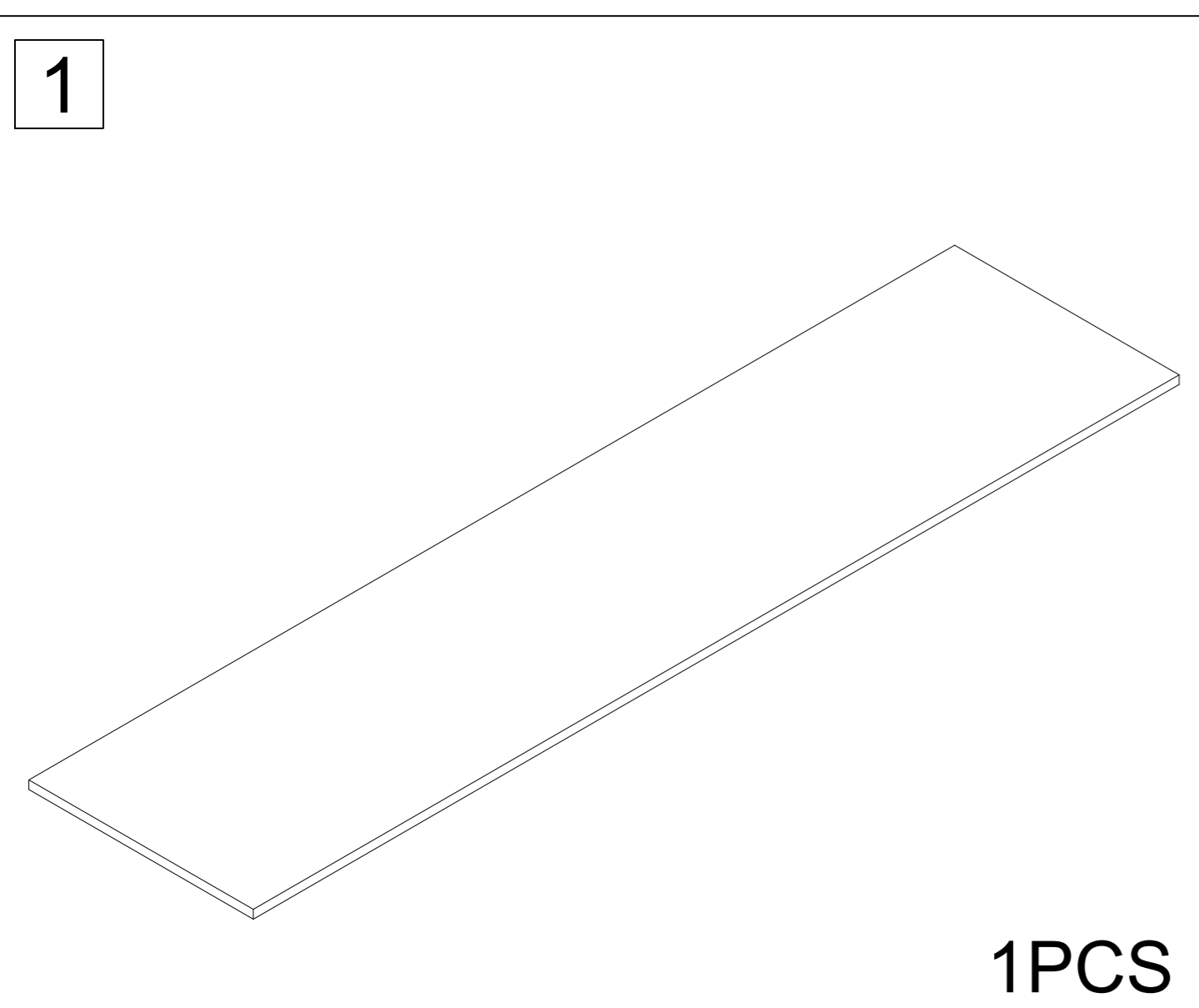

STEP 1

Make sure the screws are loose before pressing

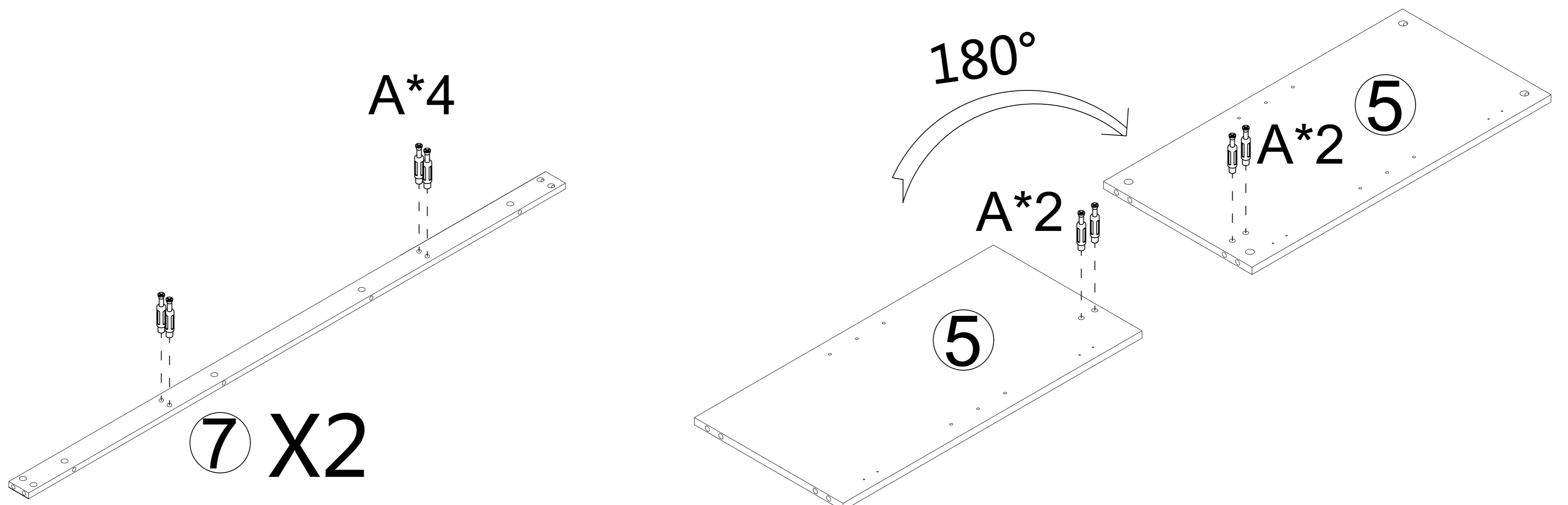
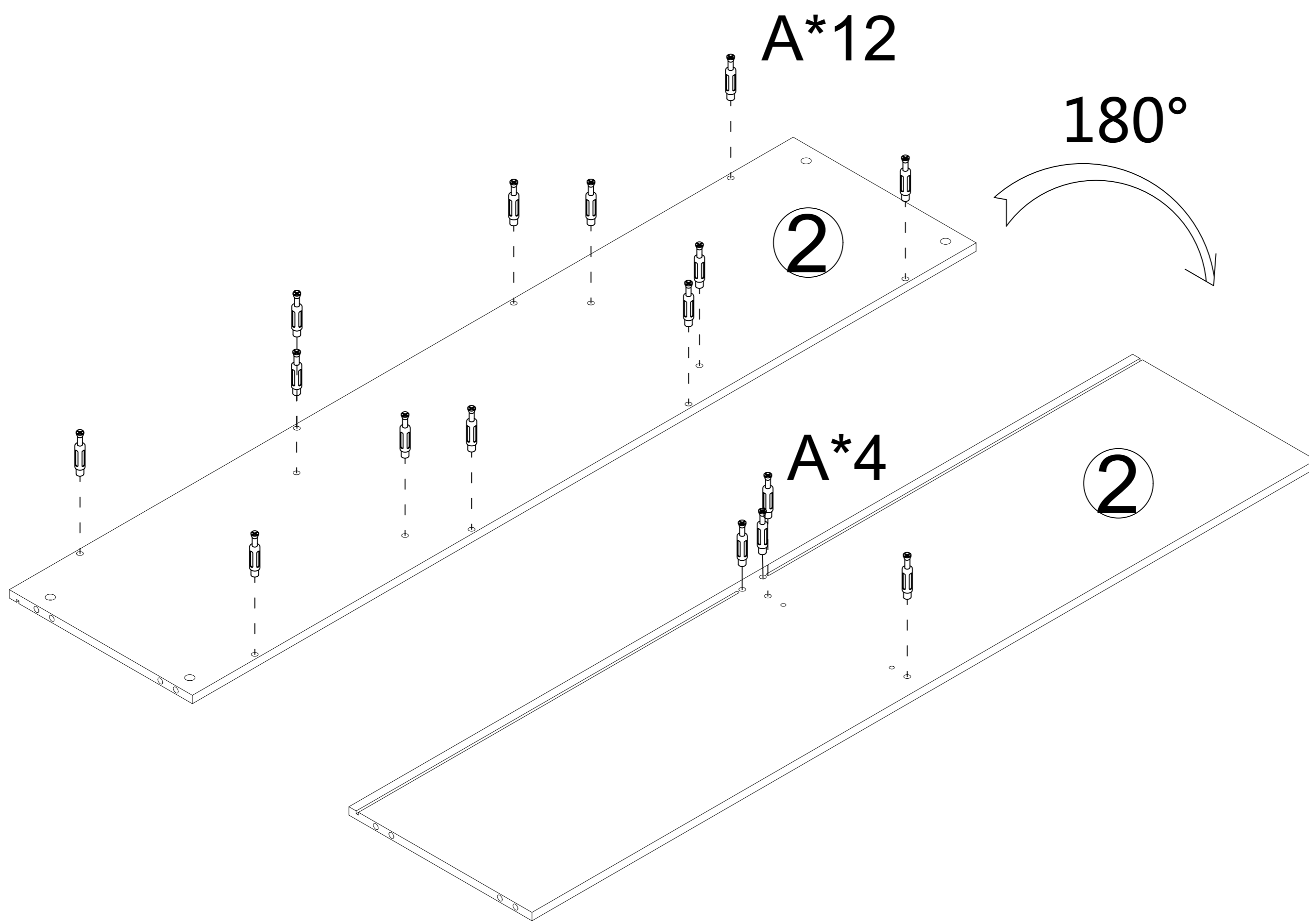
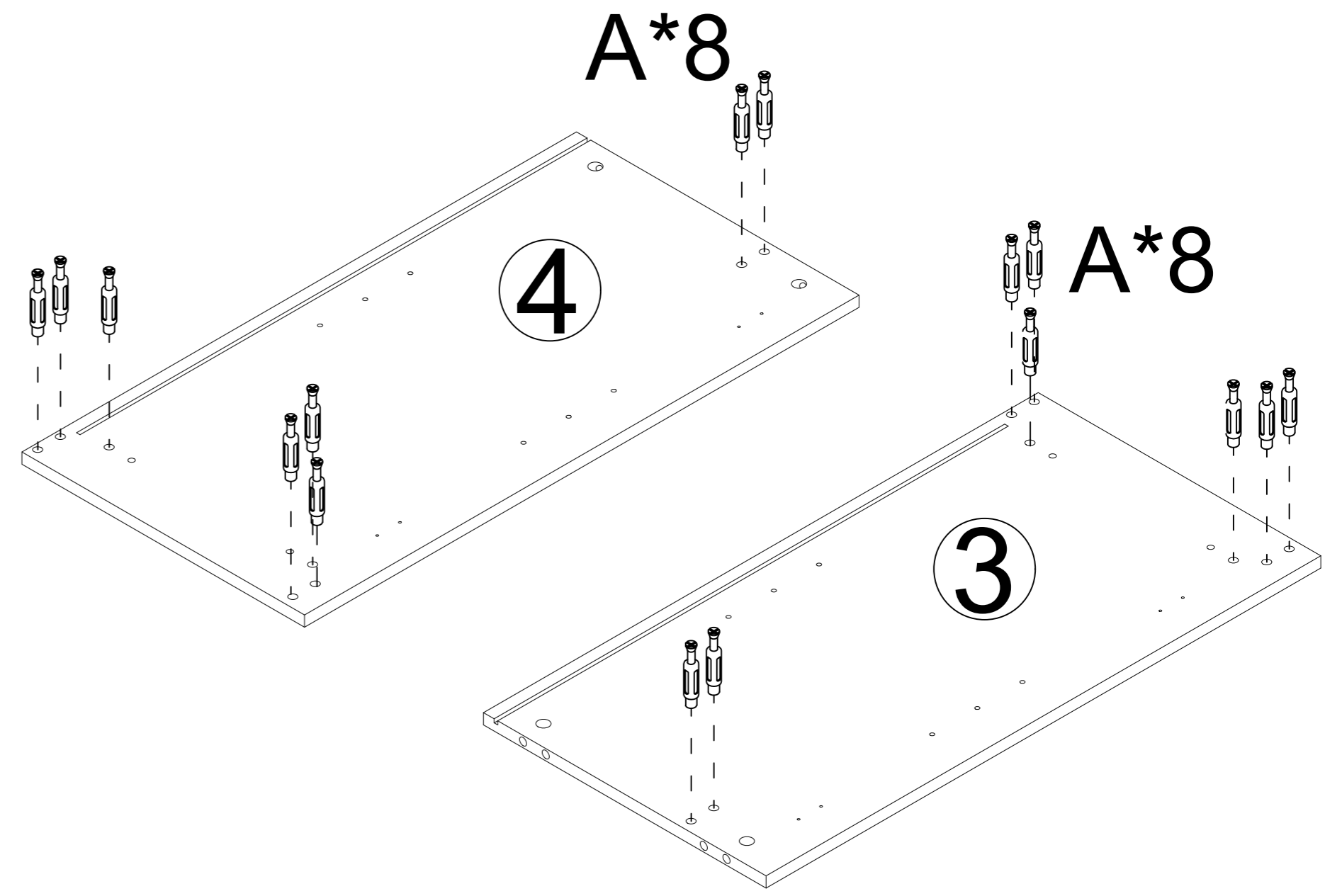
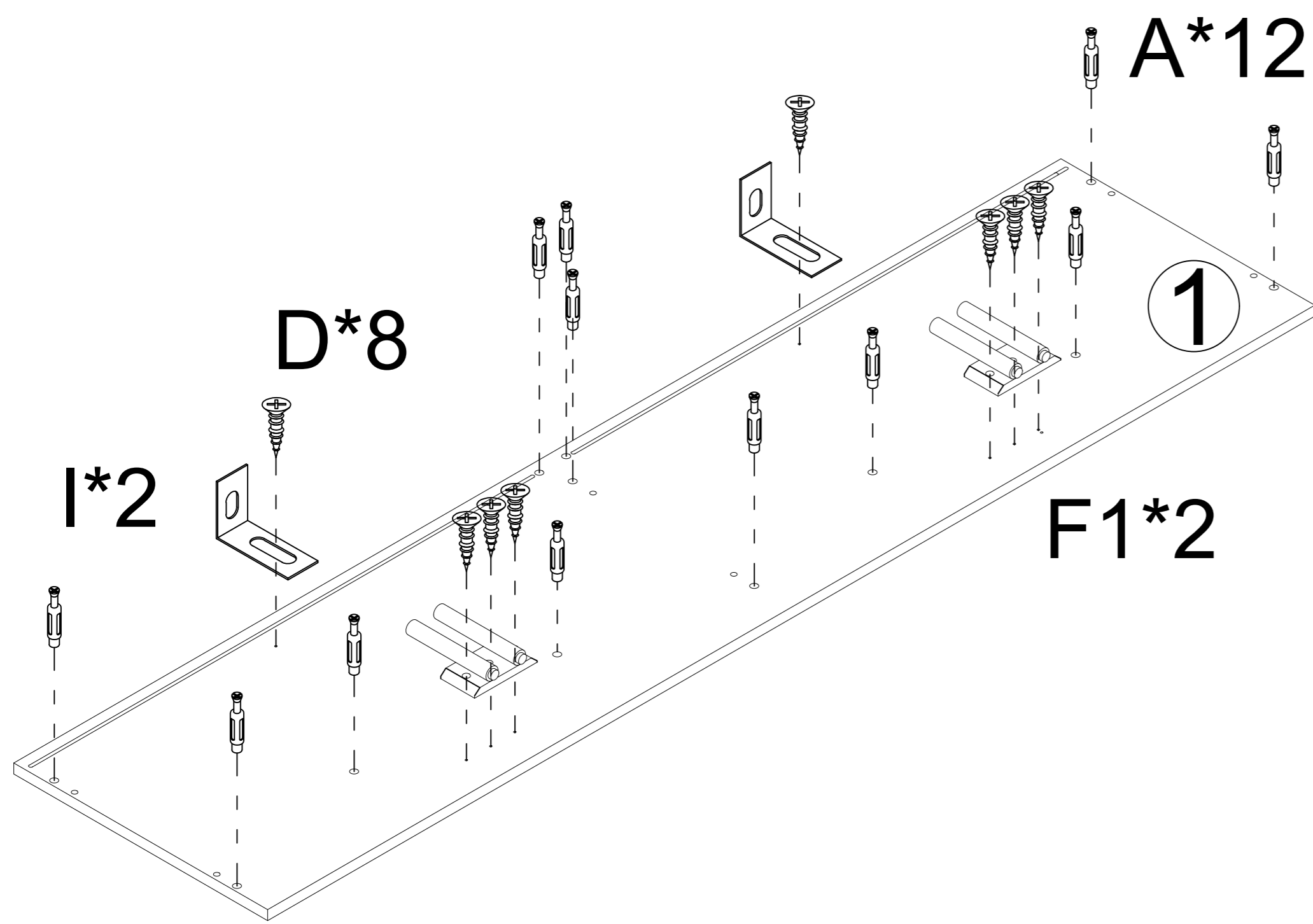
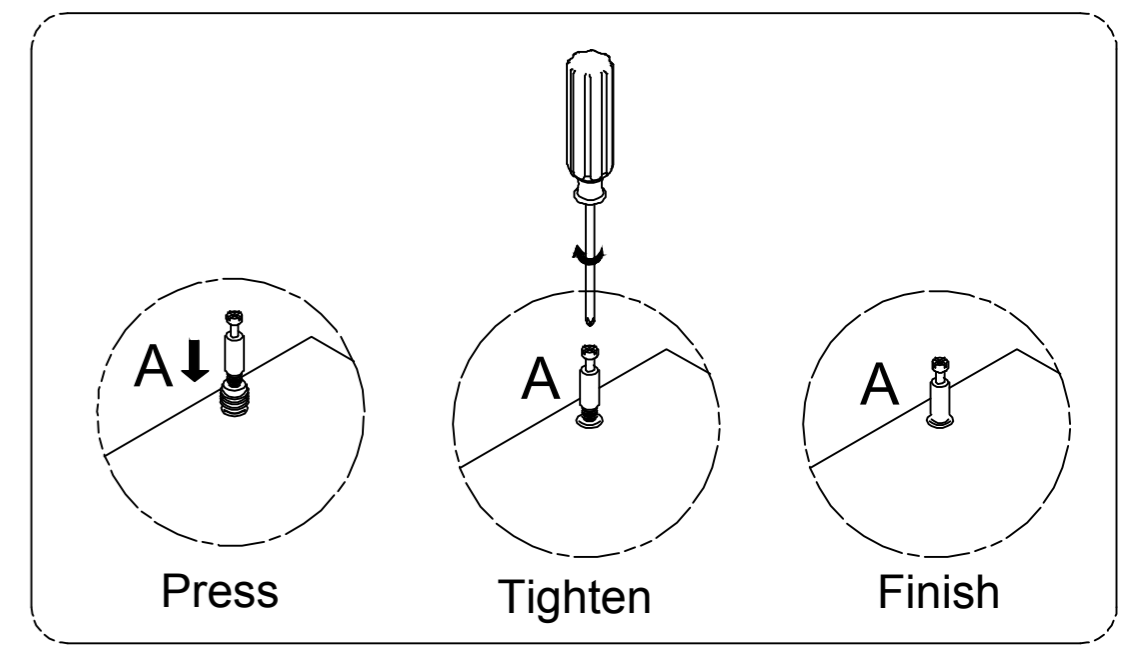
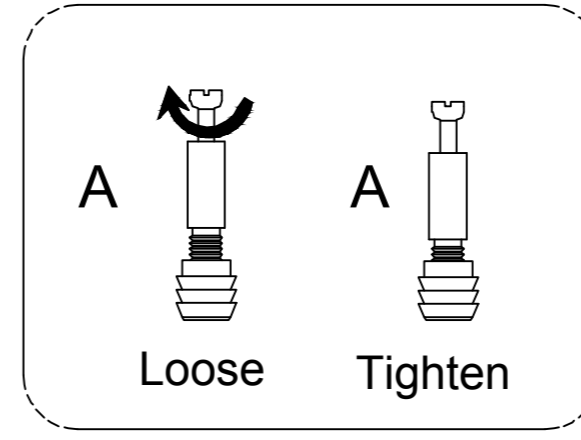

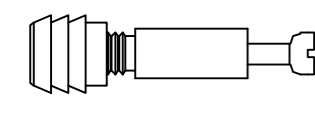
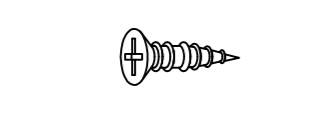
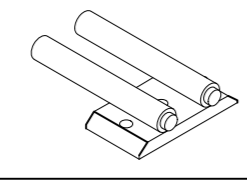
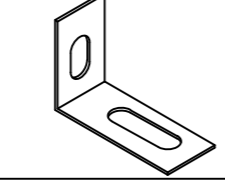
A 56PCS	D 8PCS	F1 2PCS	I 2PCS
			
Ø6*35mm	M3.5*14mm		

STEP 2

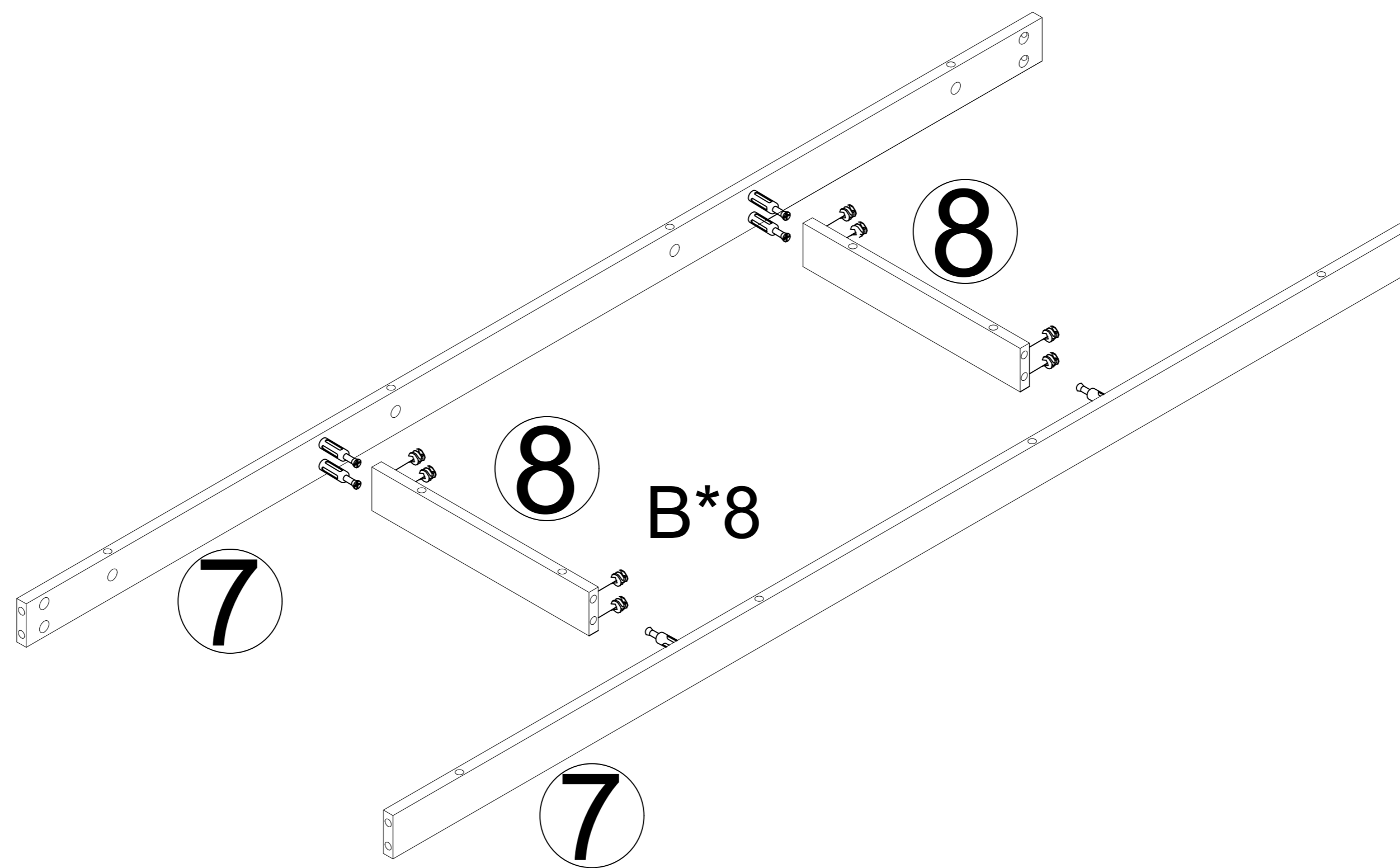

B	8PCS
	
Ø 15*11.5mm	

STEP 3

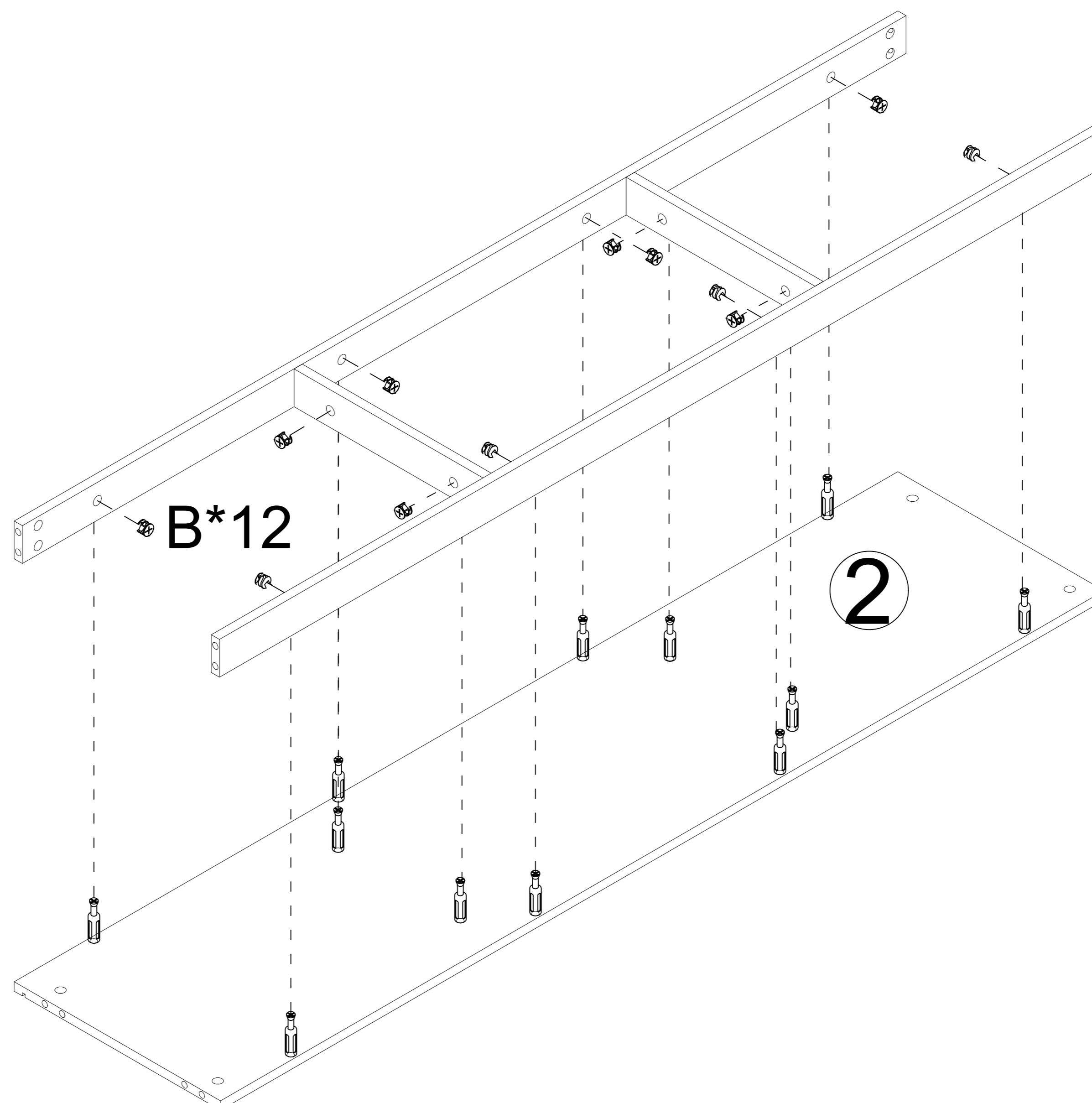

B	12PCS
	
Ø 15*11.5mm	

STEP 4

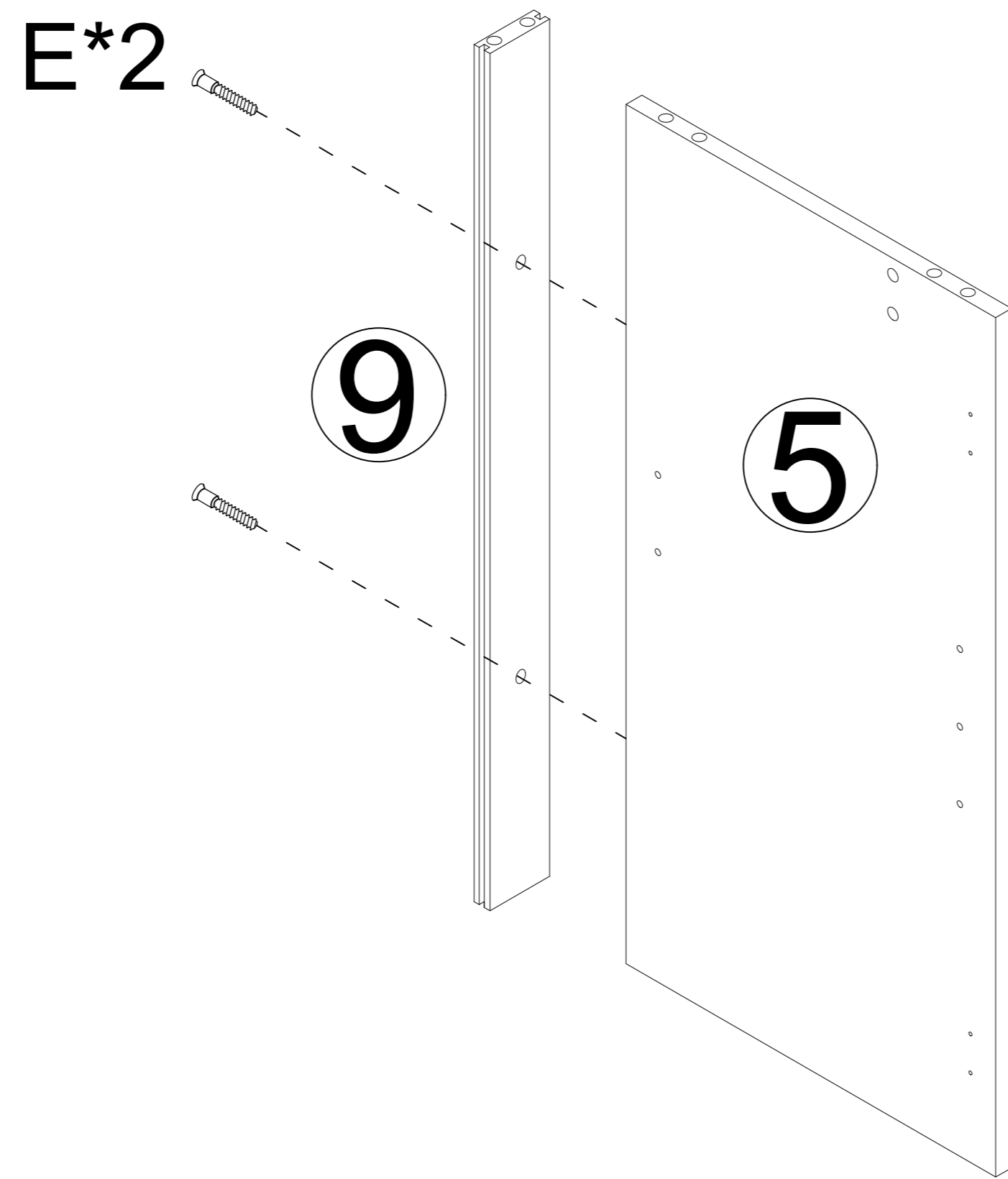

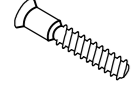
E	2PCS
	
Ø6*38mm	

STEP 5

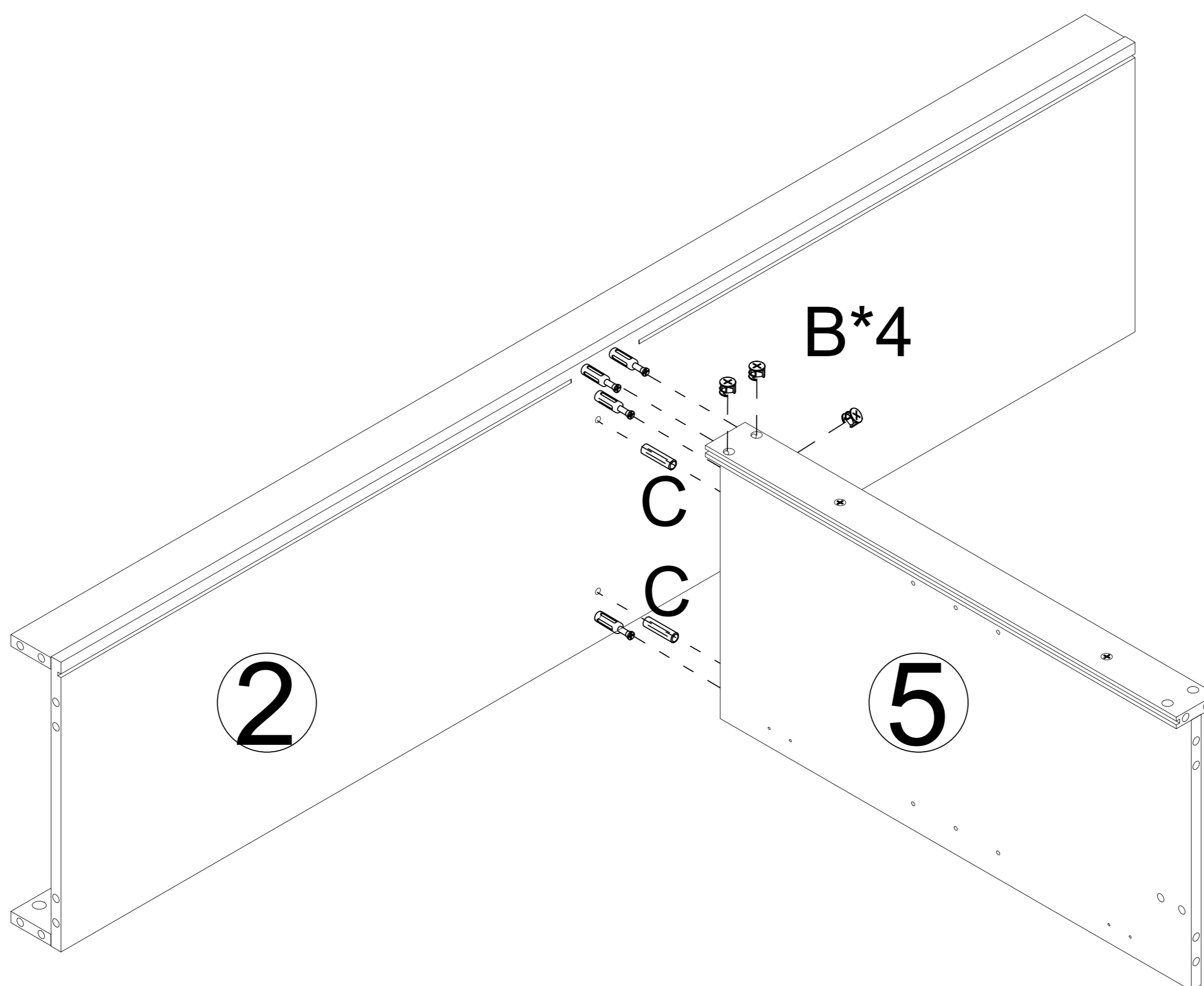

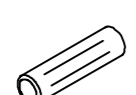
B	4PCS	C	2PCS
			
Ø 15*11.5mm		Ø8*30mm	

STEP 6

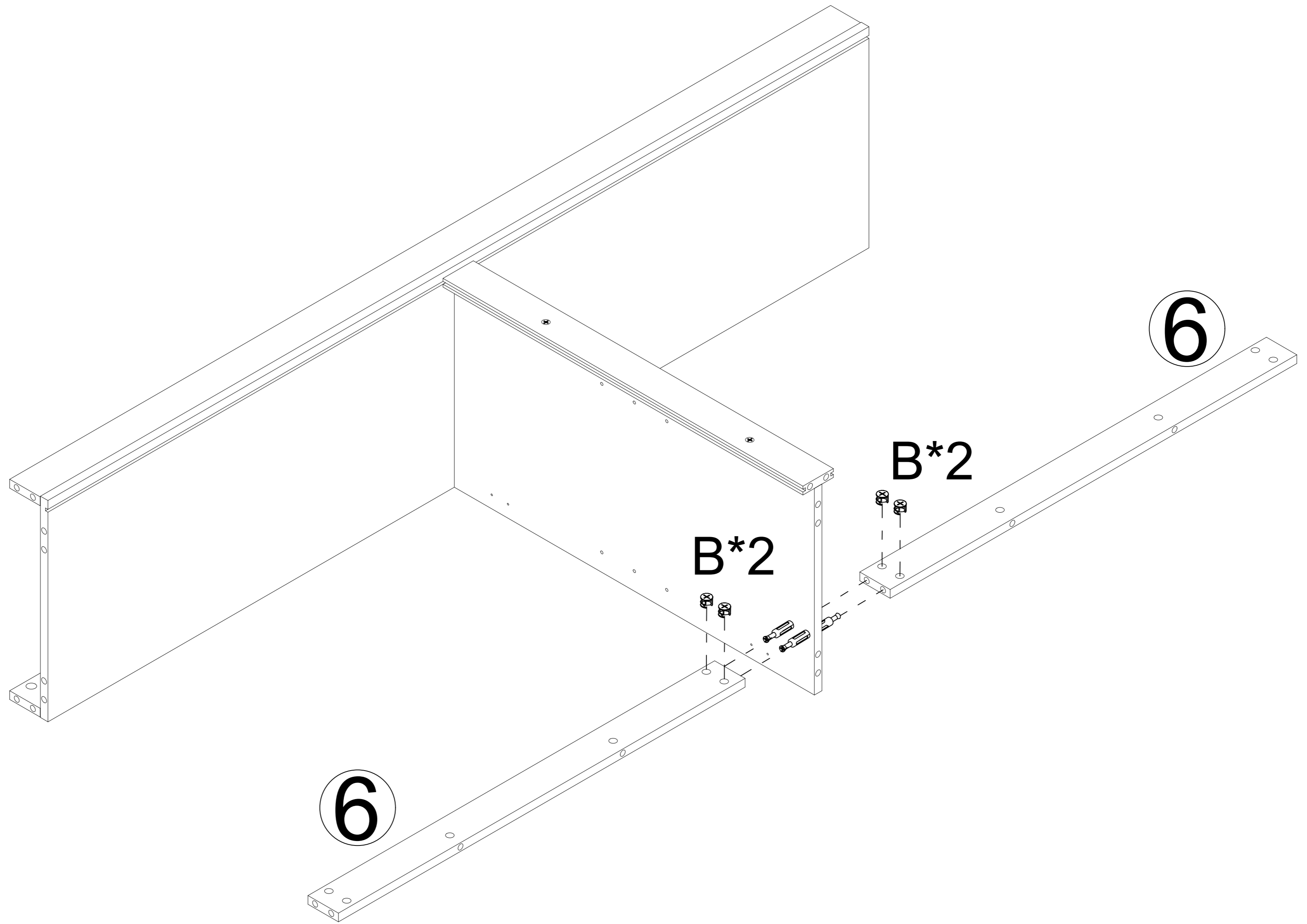

B	4PCS
Ø 15*11.5mm	

STEP 7

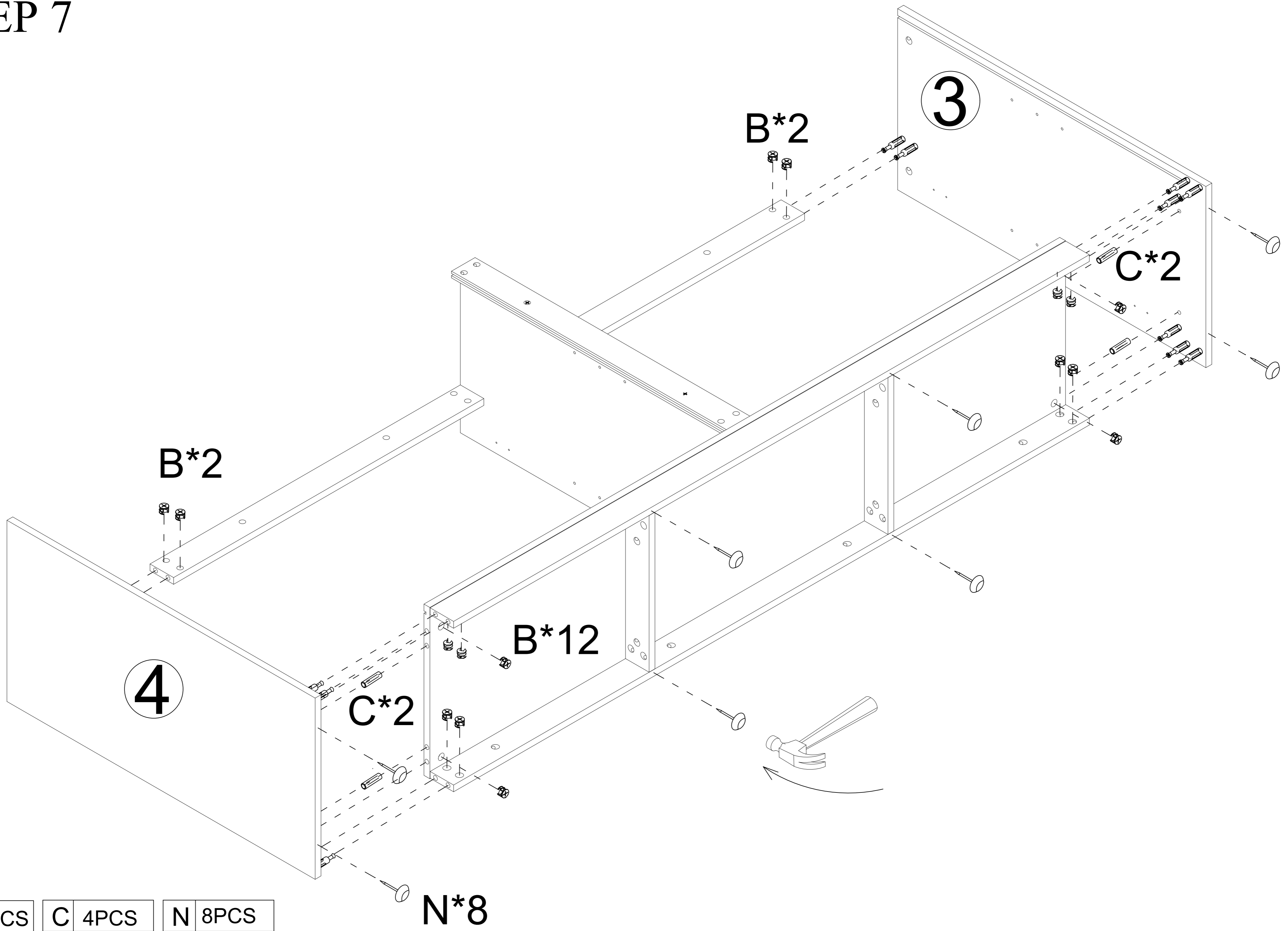

B	16PCS	C	4PCS	N	8PCS
Ø 15*11.5mm		Ø8*30mm			

STEP 8

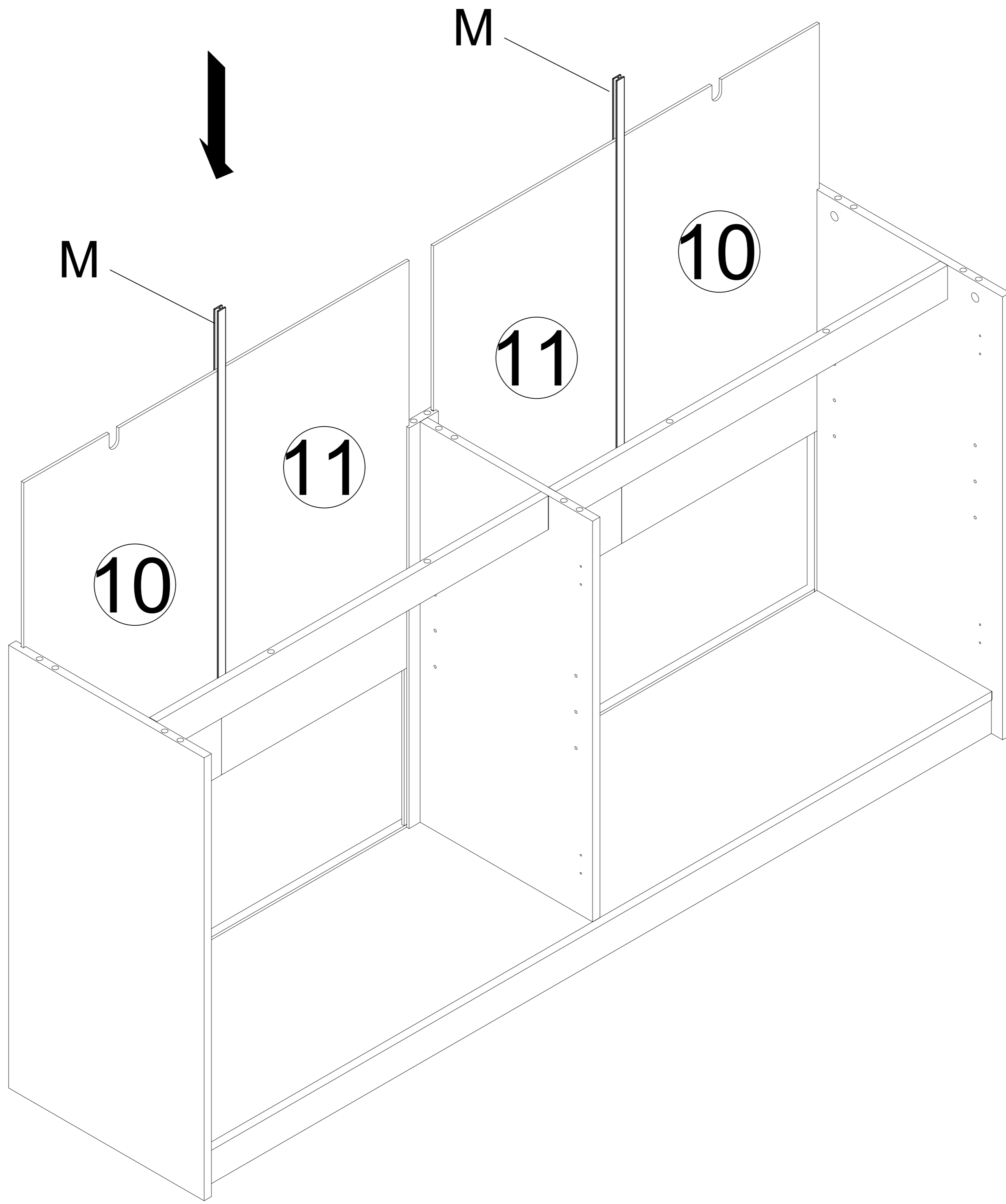

M 2PCS

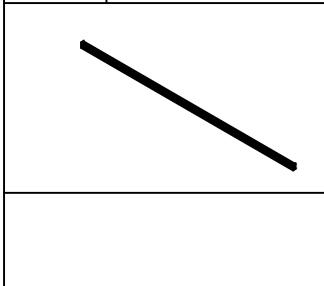

STEP 9

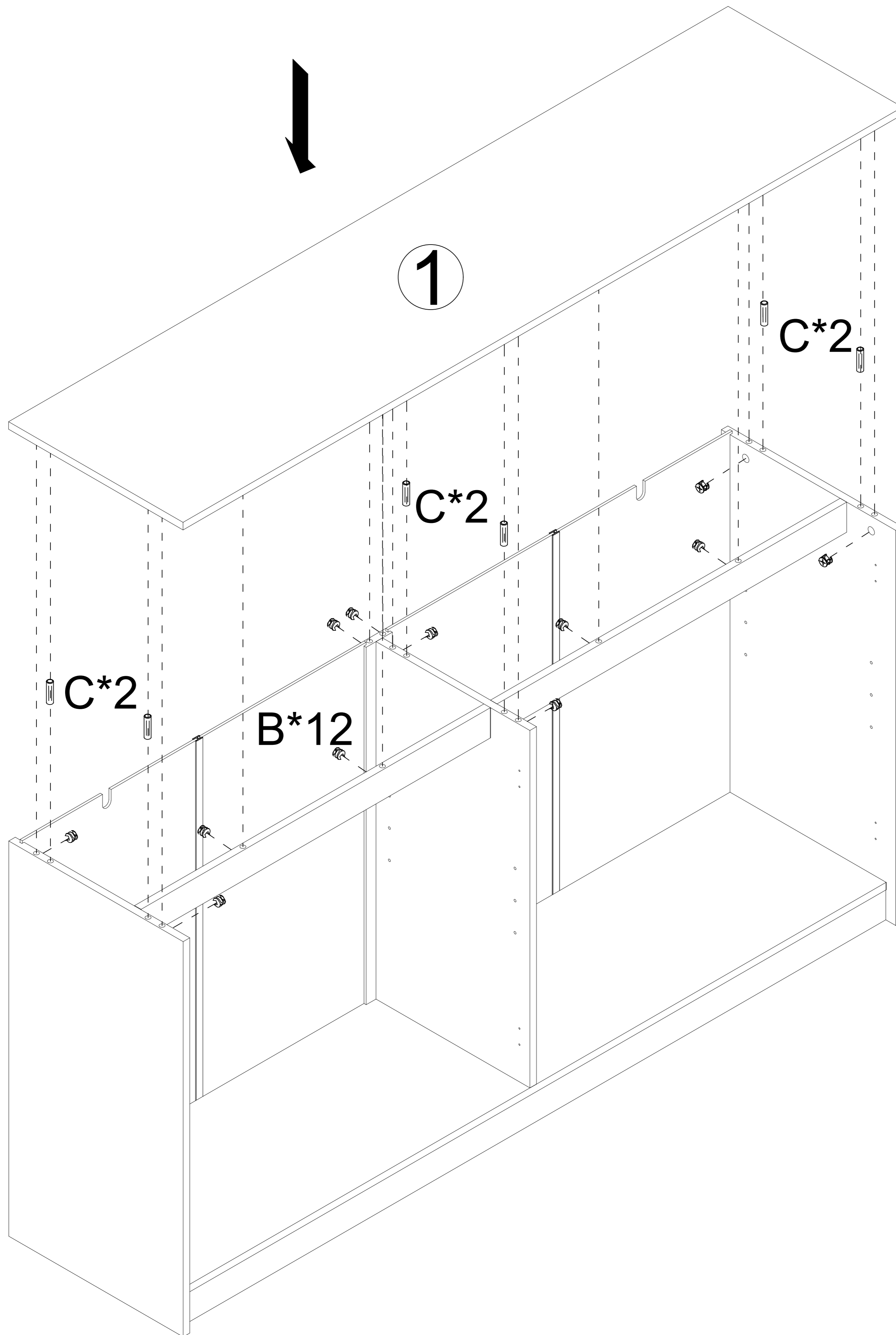

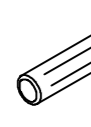
B	12PCS	C	6PCS
			
Ø 15*11.5mm		Ø8*30mm	

STEP 10

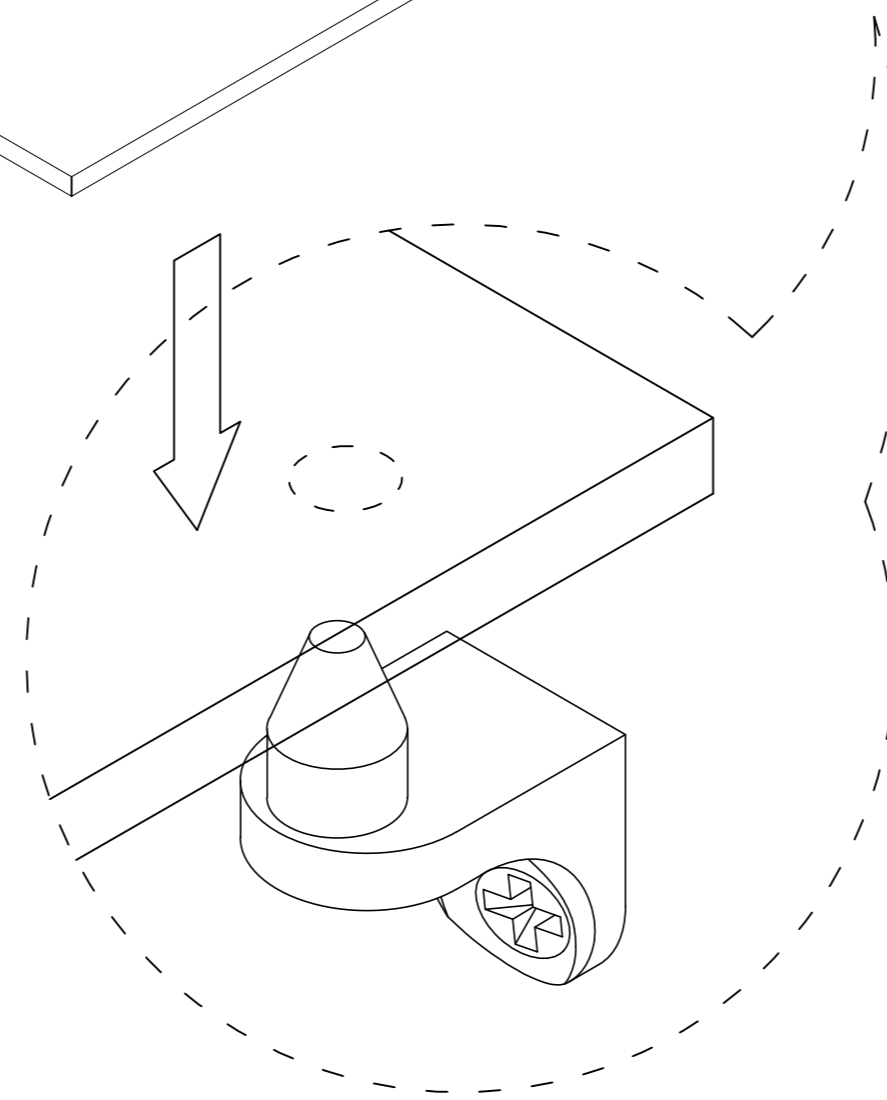
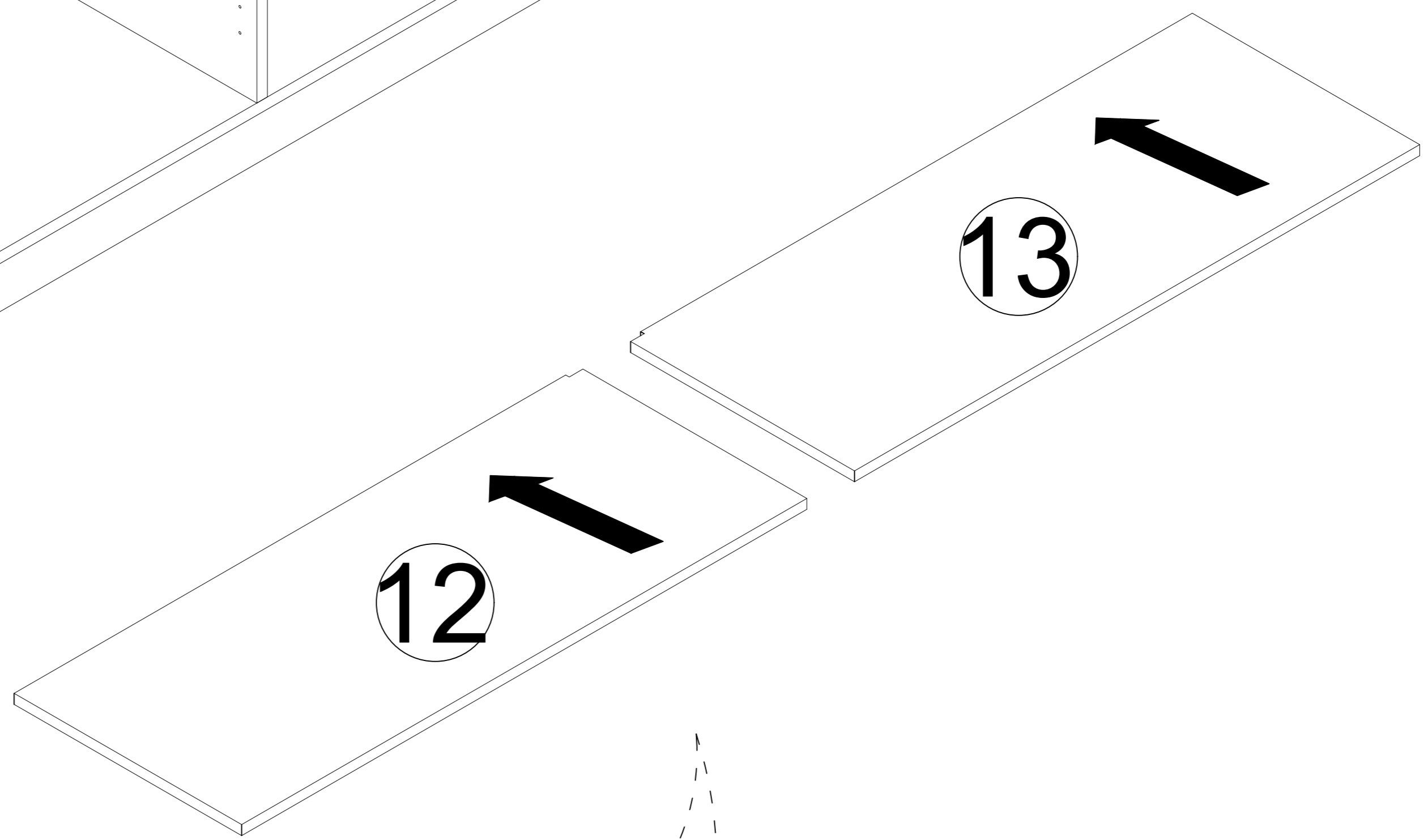
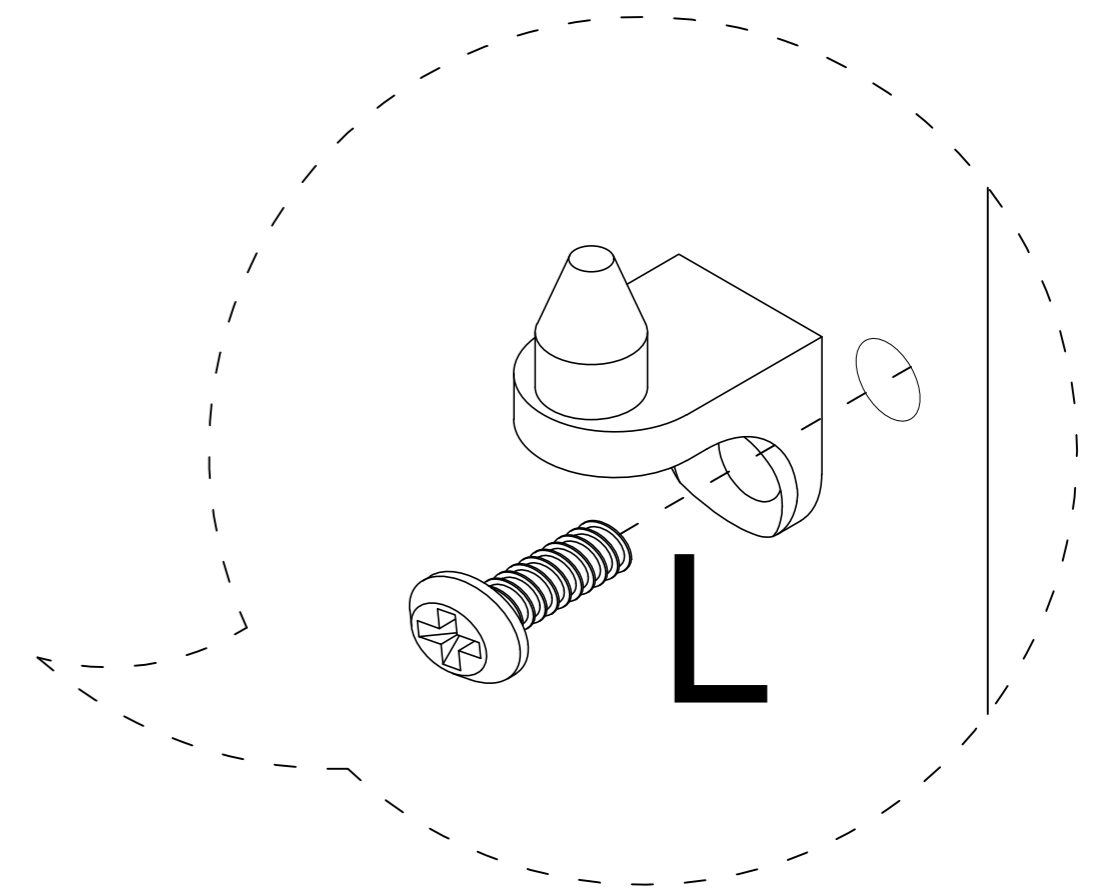
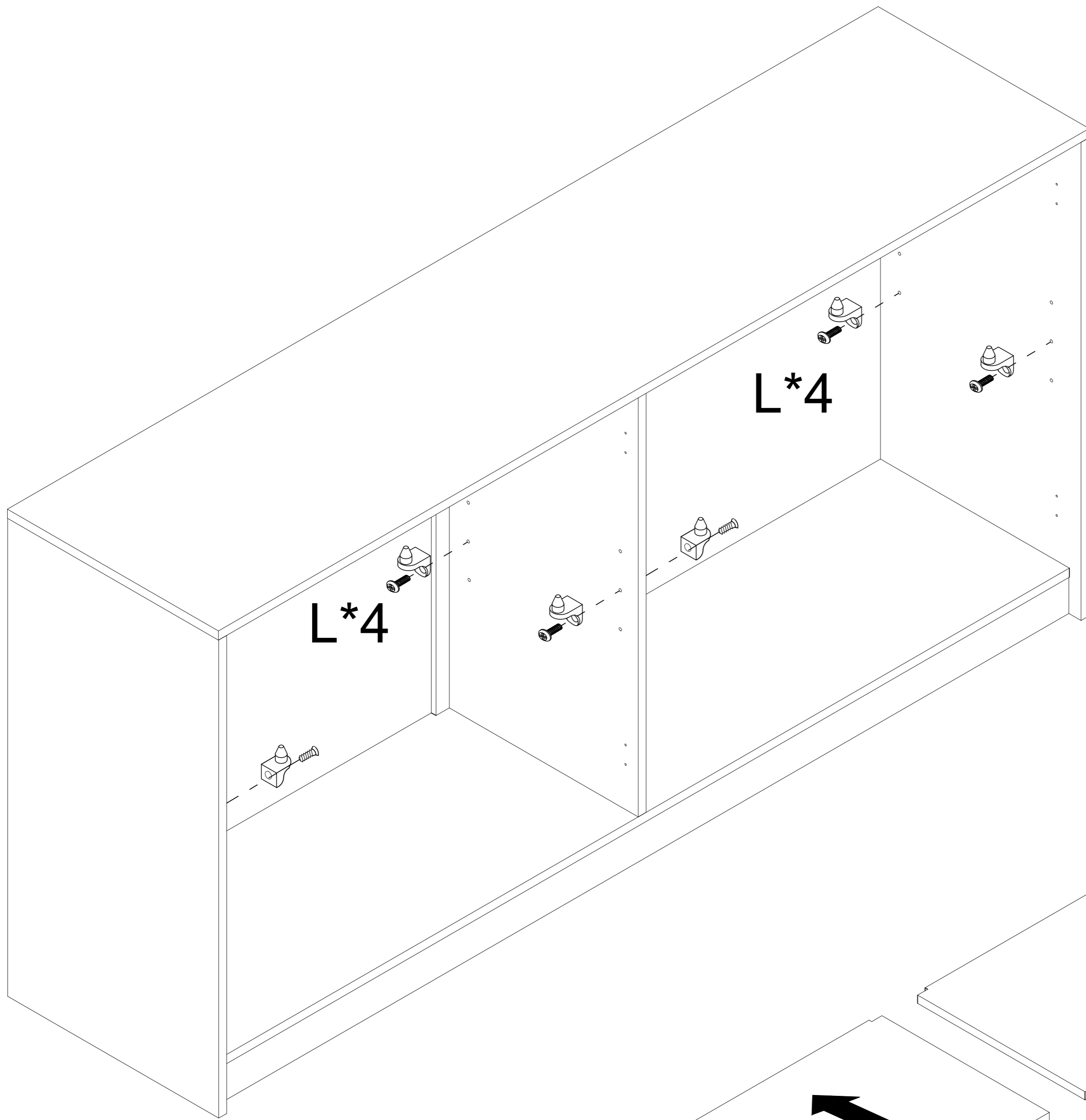

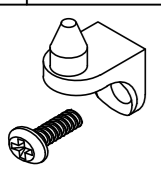

L 8PCS



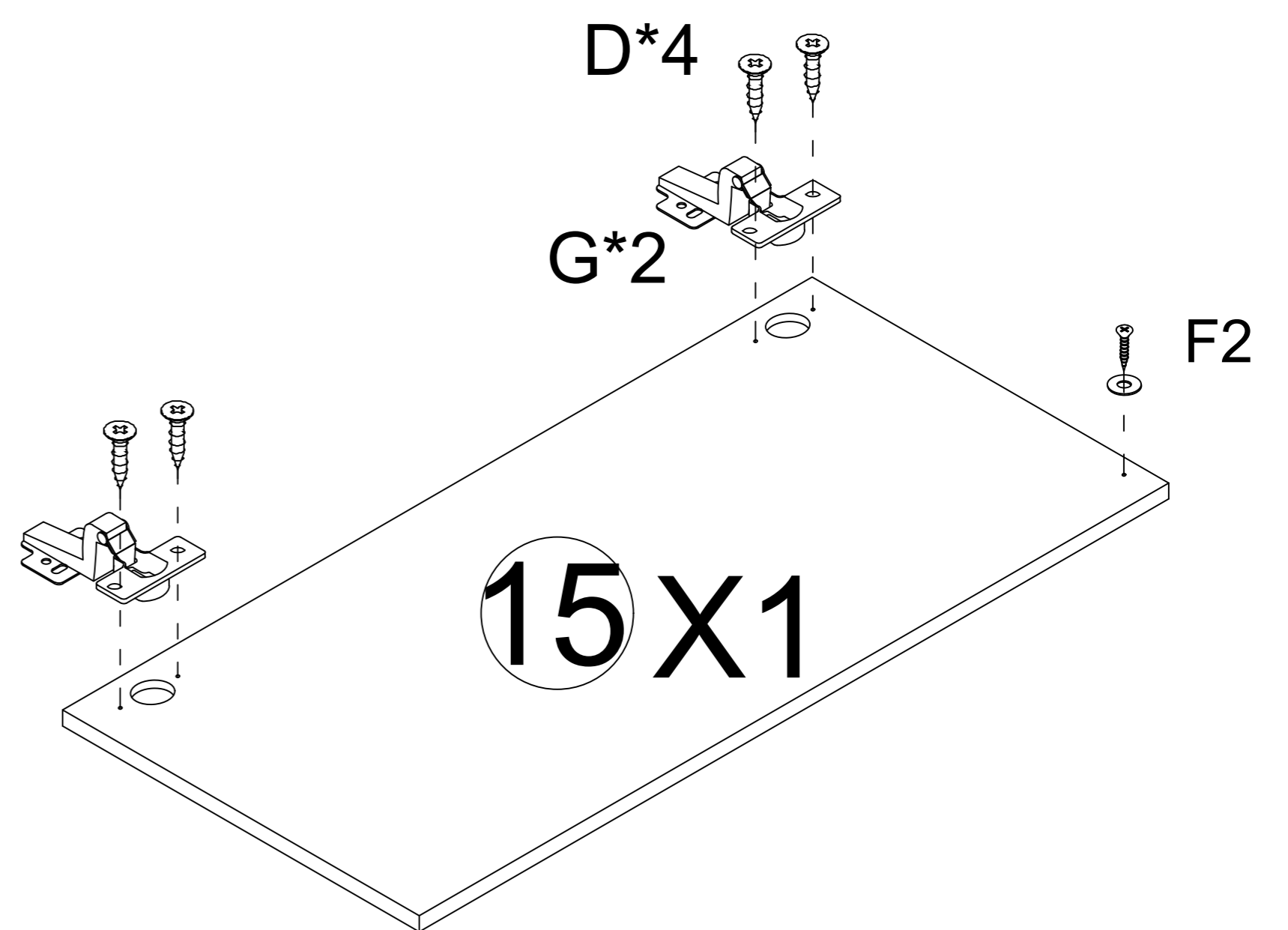
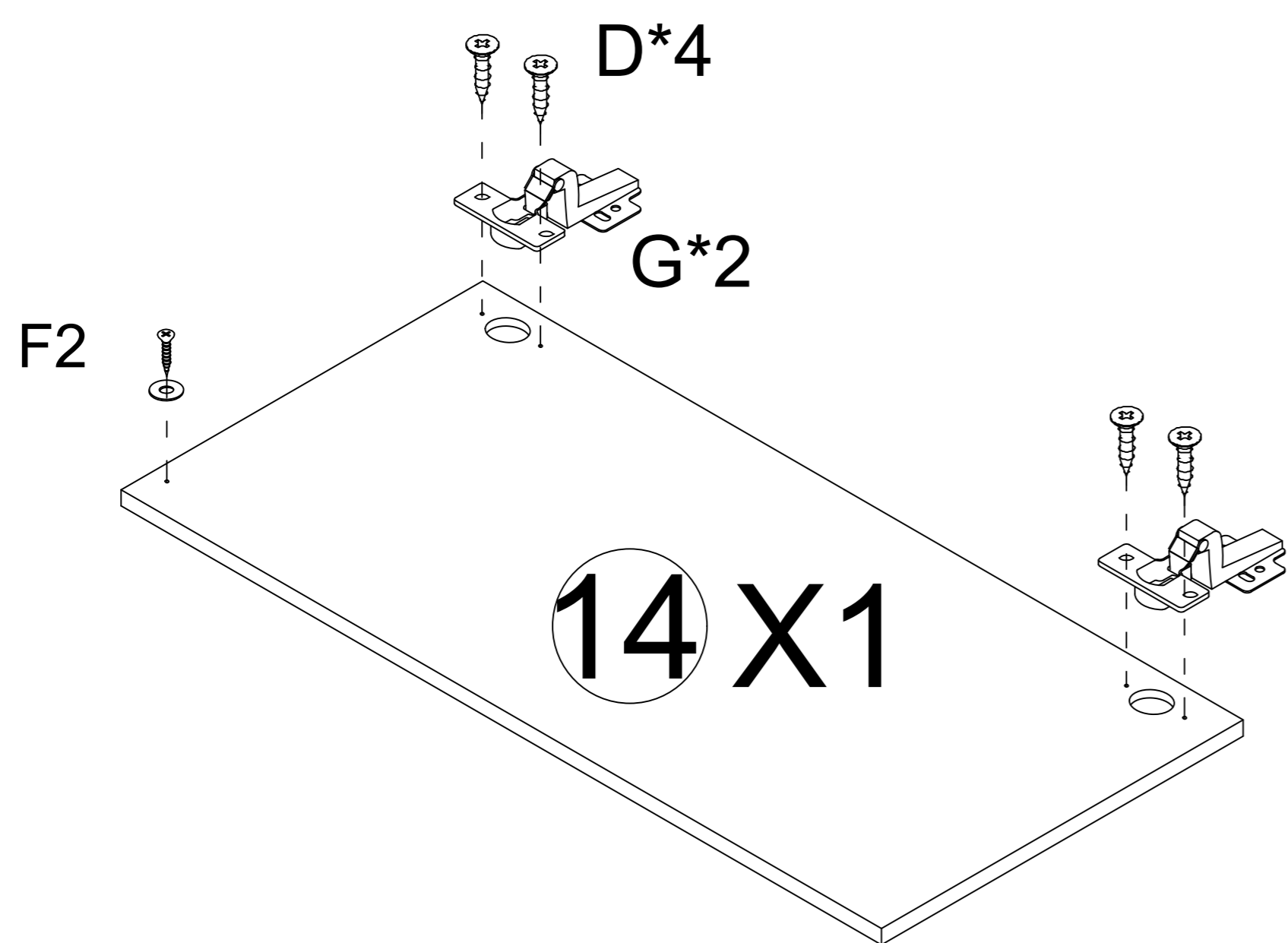

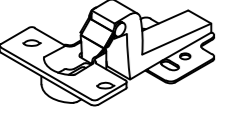
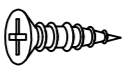
STEP 11

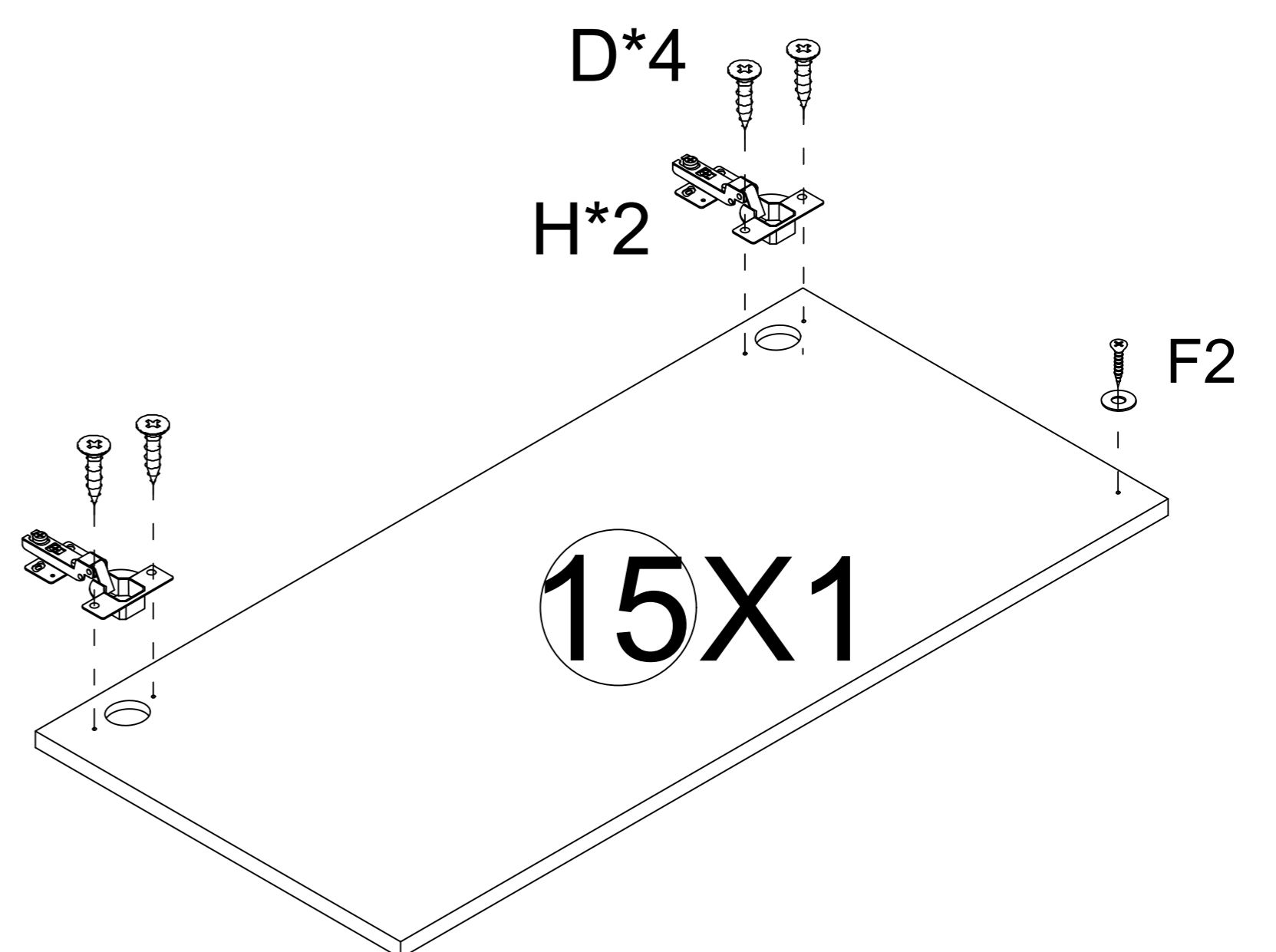
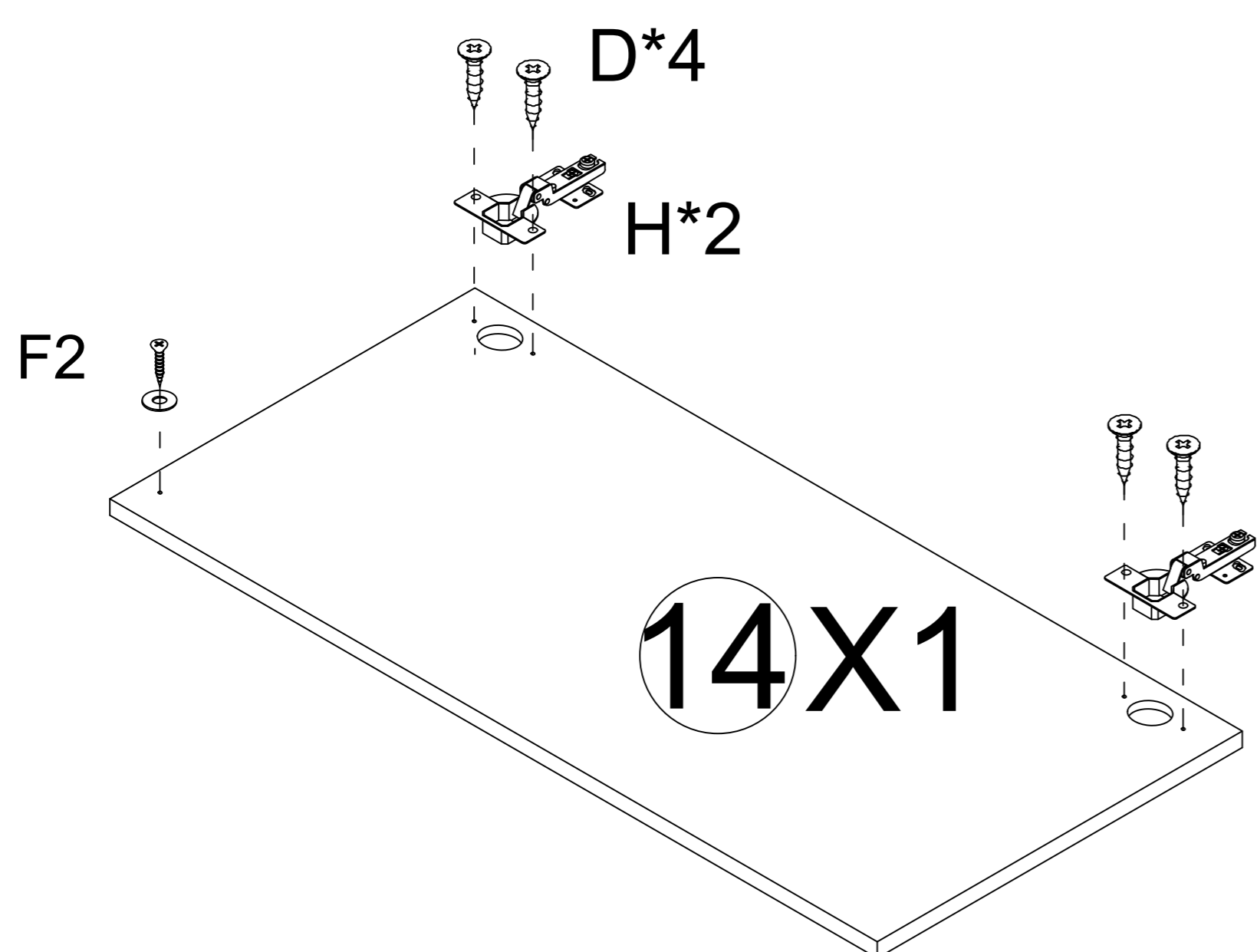

G 4PCS	D 8PCS	F2 2PCS
		
	M3.5*14mm	

STEP 12

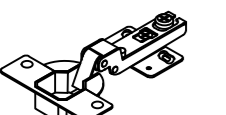

H 4PCS	D 8PCS	F2 2PCS
		
	M3.5*14mm	

STEP 13

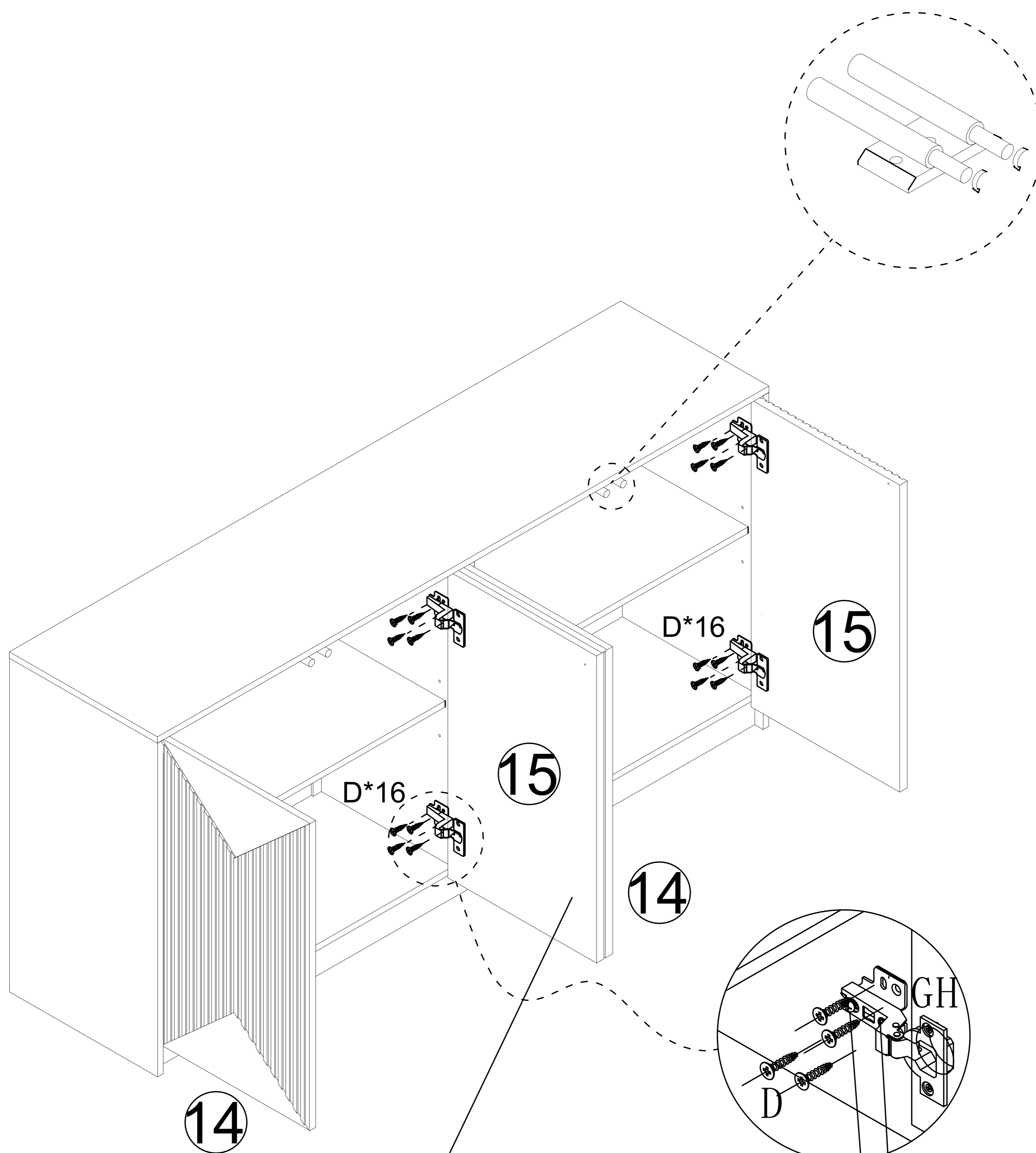

The two screws on the front and back can adjust the gap of the door panel.

Please note that for the door panel numbered 14 and 15, the hinge "H" should be installed.

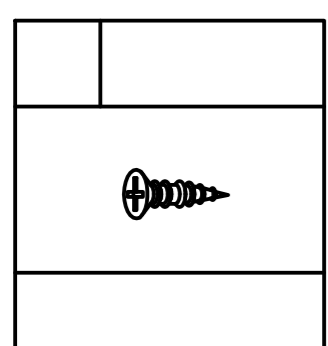

STEP 14

Door hinge adjustment method

Method 1:

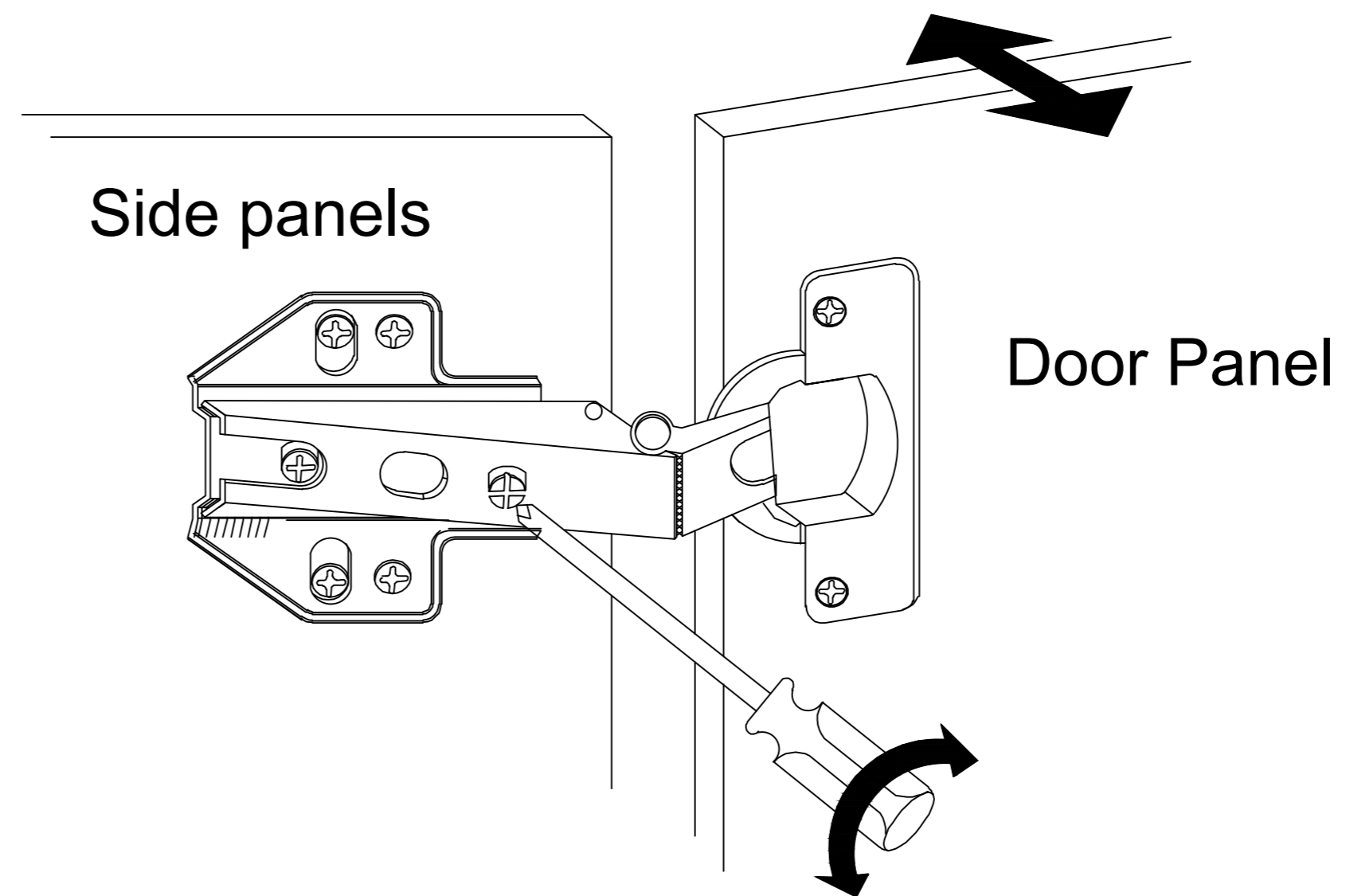
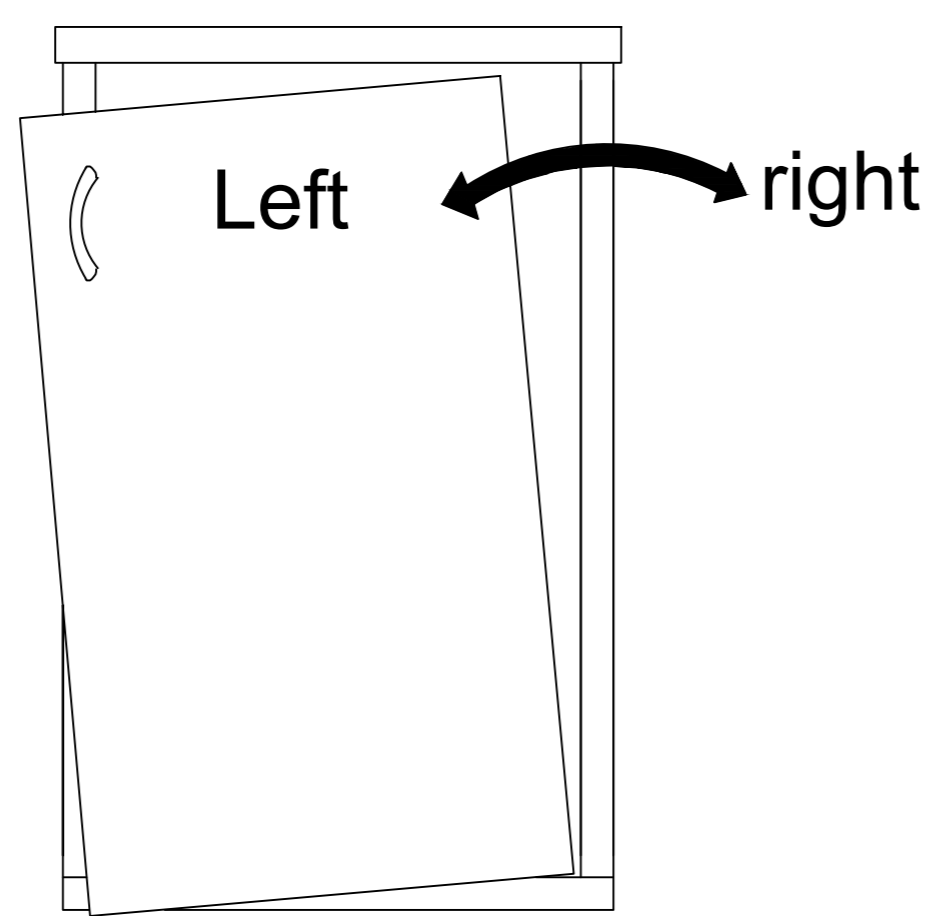

Method 2:

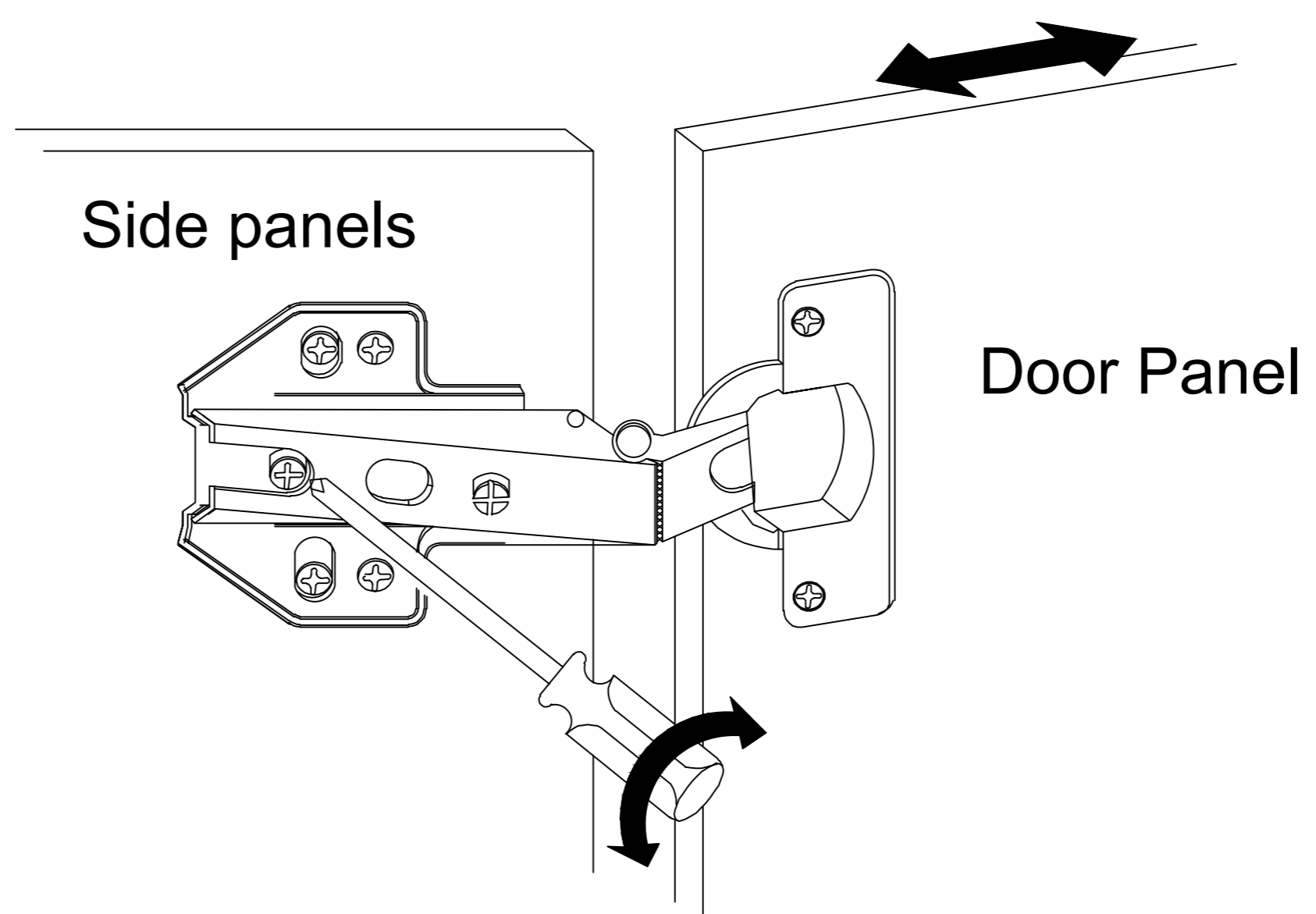
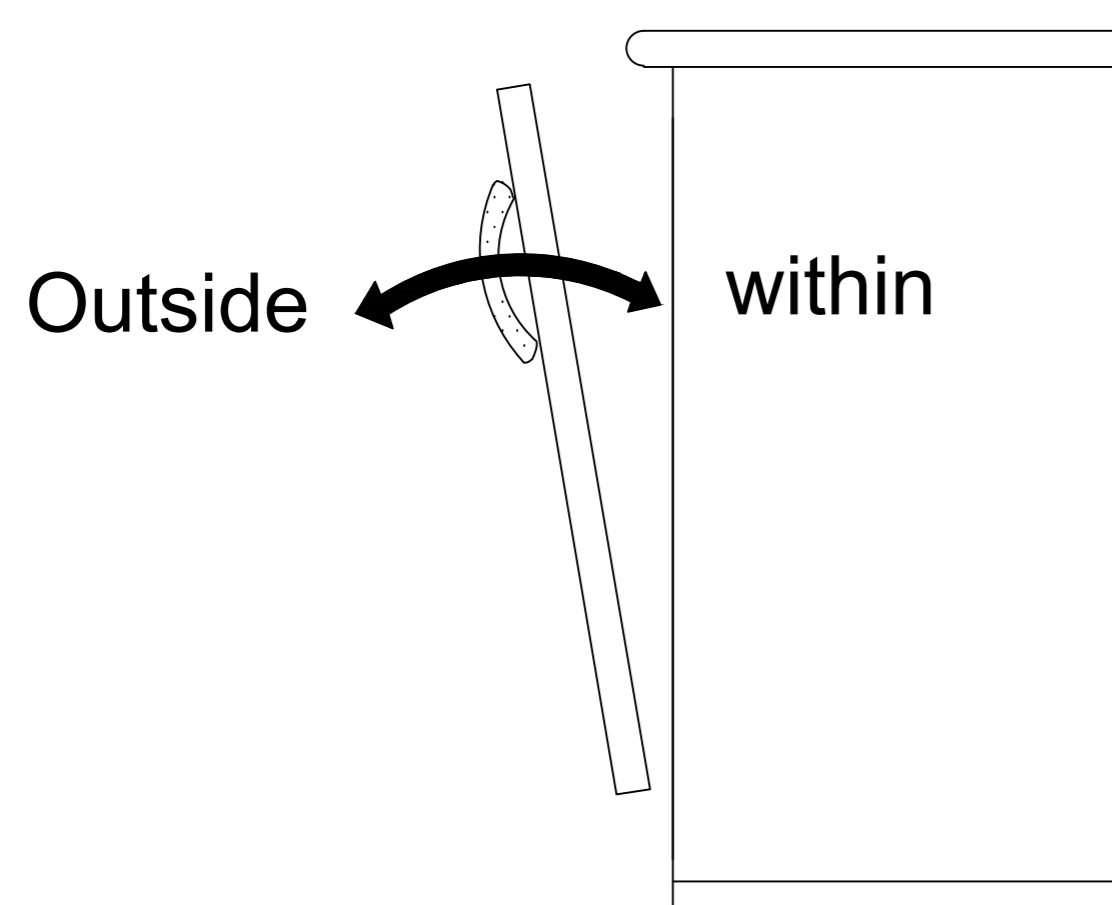

Method 3:

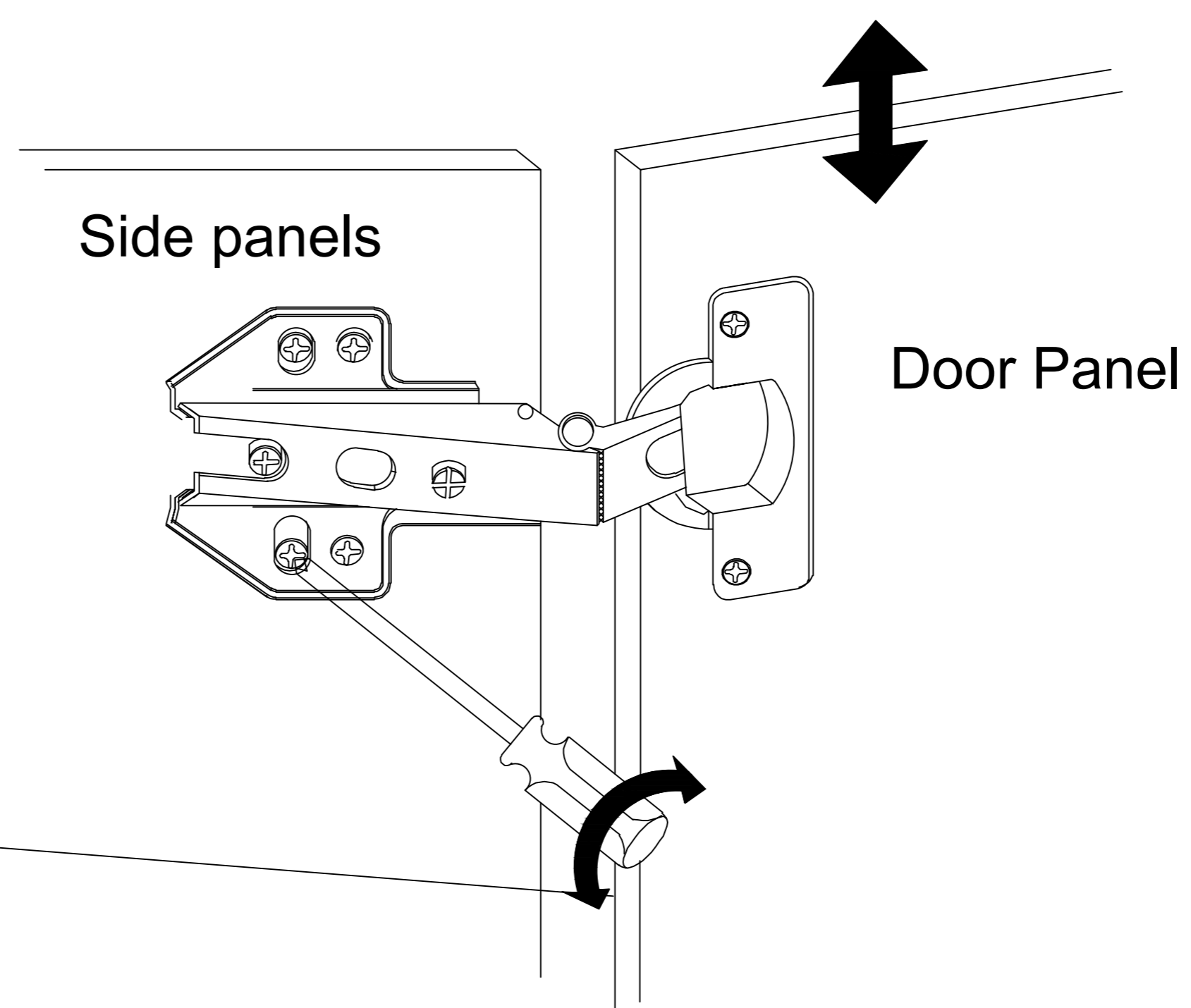
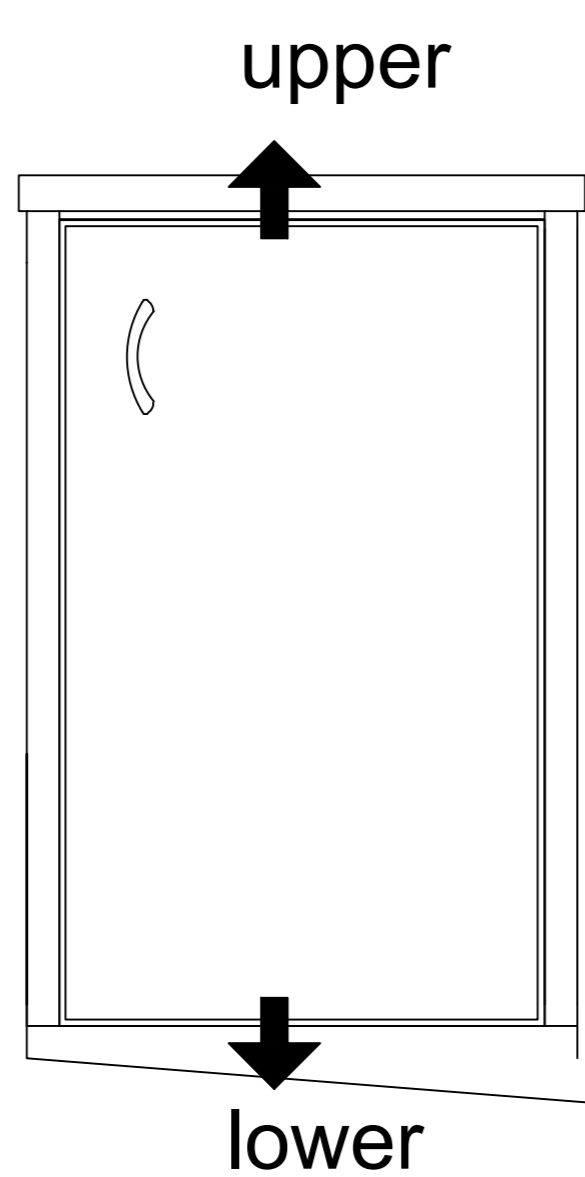

STEP 15

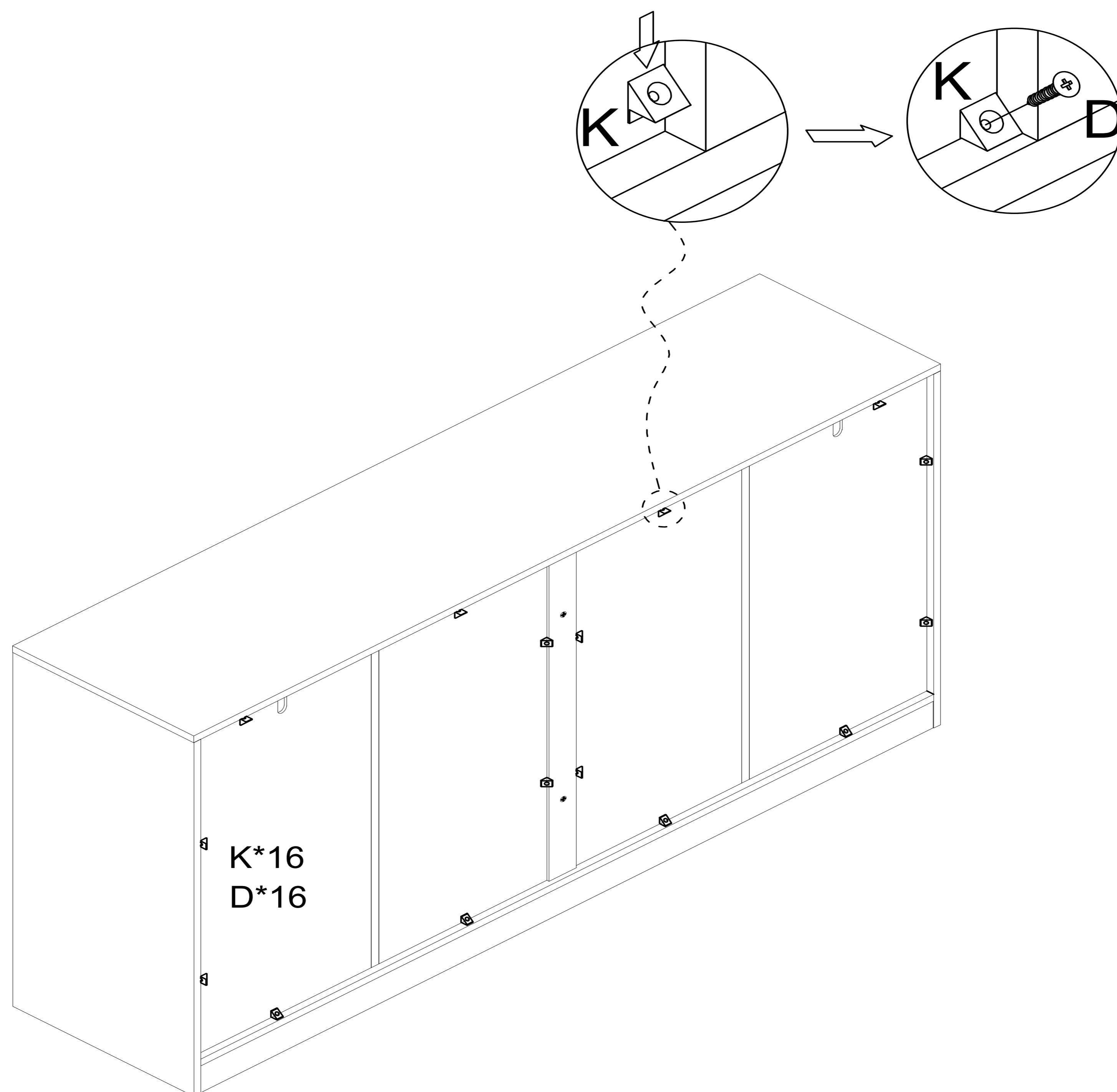

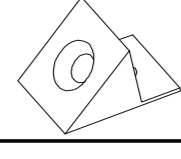
D	16PCS	K	16PCS
			
M3.5*14mm			

STEP 16

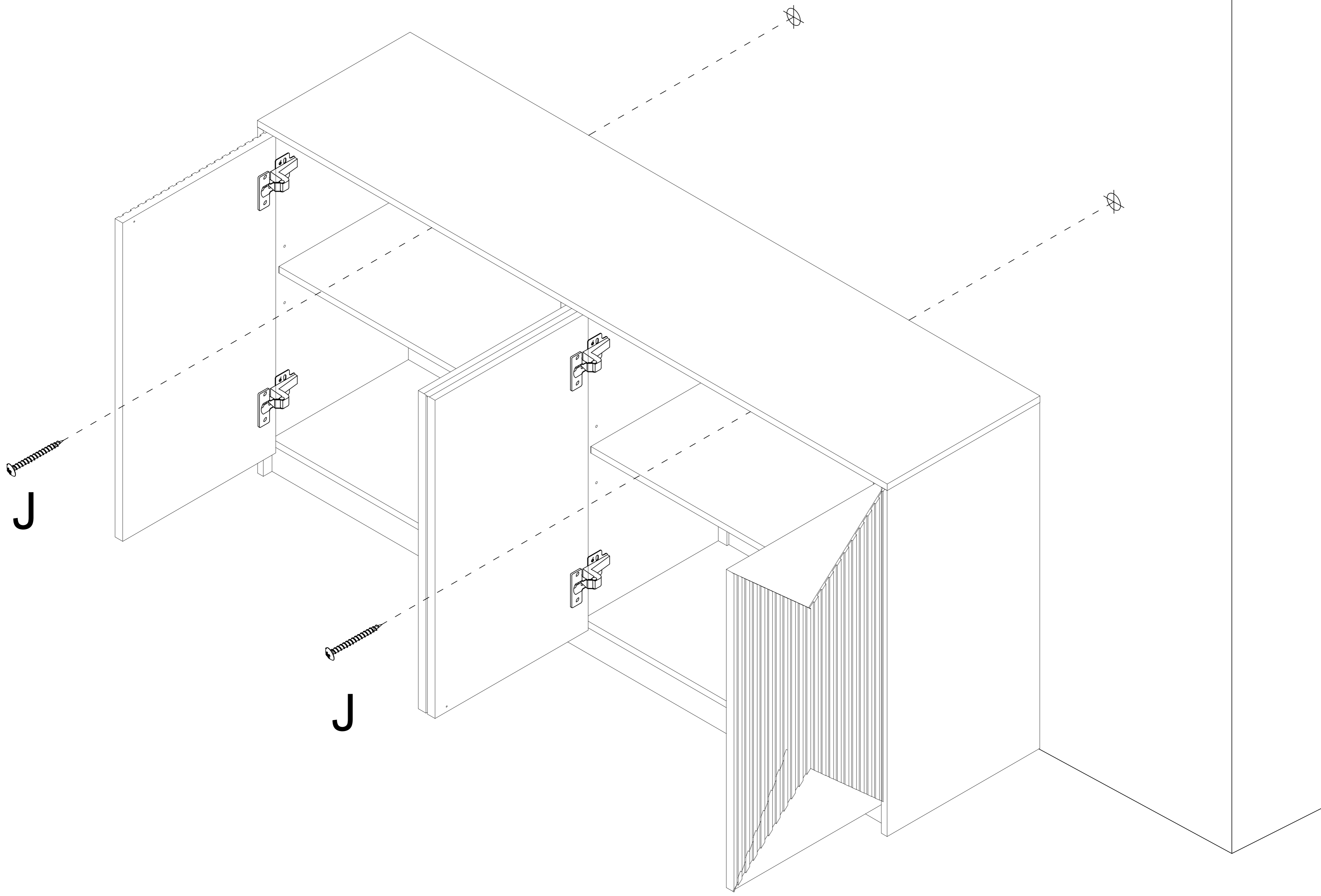
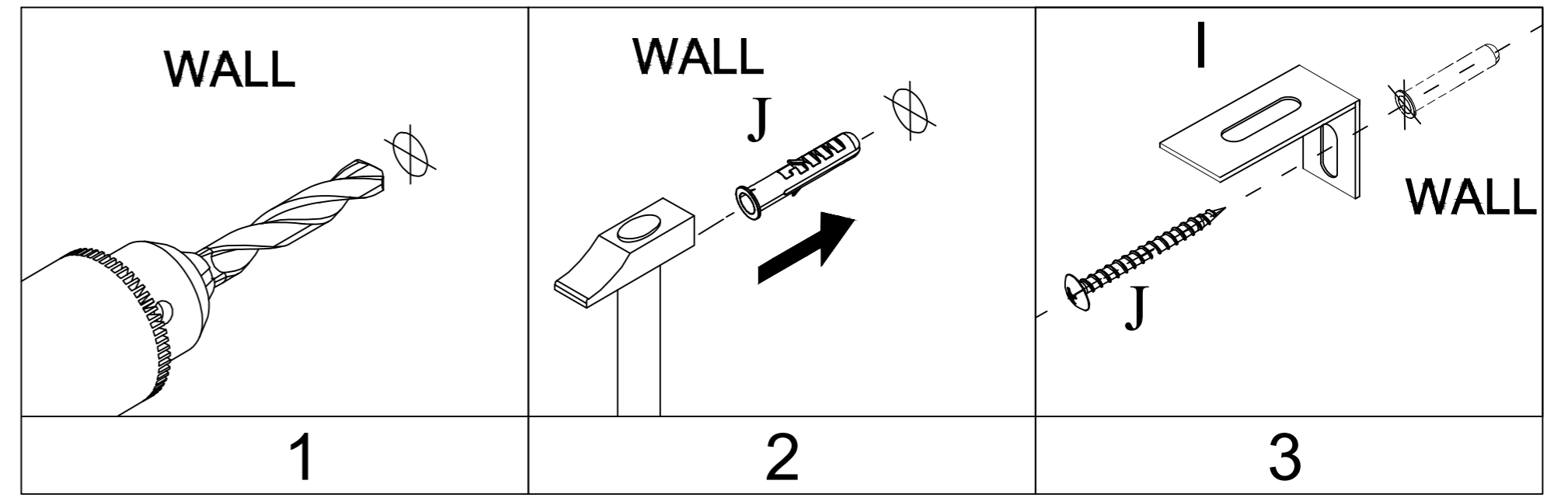

J	2PCS
