





CARE AND MAINTENANCE

Spot clean using a mild water-free solvent. Only a professional cleaner should undertake a complete overall cleaning.
The use of steam or water-based cleaners may cause excessive shrinking or staining.

NOTICE

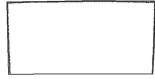
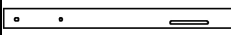
- * Please make sure that you have all parts indicated before you begin assembly of this item
- * This item should be assembled on a soft surface to prevent scratching the finish during assembly
- * This item may require periodic tightening

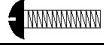
Part List and Hardware List

A	HEADBOARD		1X
B	METAL LEG		2X
H1	NUT		4X
H2	WASHER		12X
H3	BIG BOLT		4X
H4	SMALL BOLT		4X

THE HARDWARE THAT IS NEEDED TO CONNECT THE HEADBOARD TO THE BED FRAME IS INCLUDED.

ASSEMBLY INSTRUCTIONS APPLICABLE FOR ALL HEADBOARDS.

THE DESIGN OF THE HEADBOARD IN THE DRAWINGS MAY VARY FROM YOUR ACTUAL HEADBOARD, BUT ASSEMBLY IS THE SAME ON ALL MODELS AND SIZES.

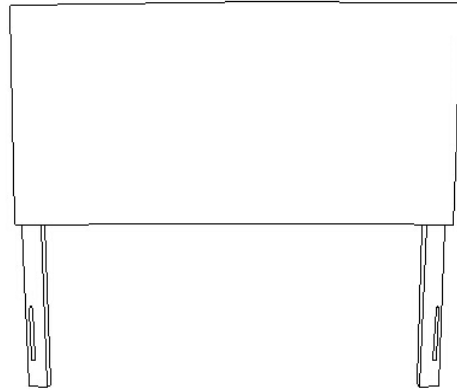

PREPARATION

Before beginning assembly of product, make sure all parts are present. Compare parts with package contents list and hardware contents list.
If any part is missing or damaged, do not attempt to assemble the product.
Estimated Assembly Time: 10 minutes.

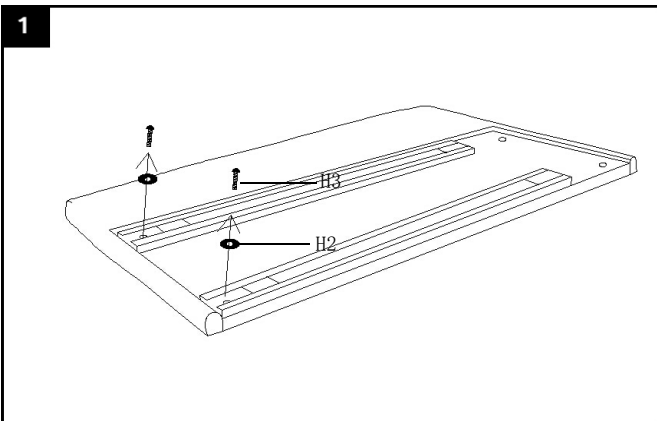

Step 1
Remove the legs from the back of the headboard.

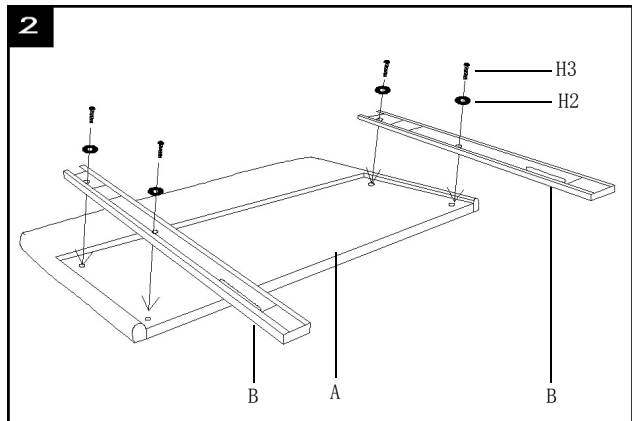

Step 2
Attach the two legs (B) to the headboard (A) using 4 big bolts (H3) and 4 washers (H2).
The vertical slots at the lower part of the leg must be facing the outside of the bed.

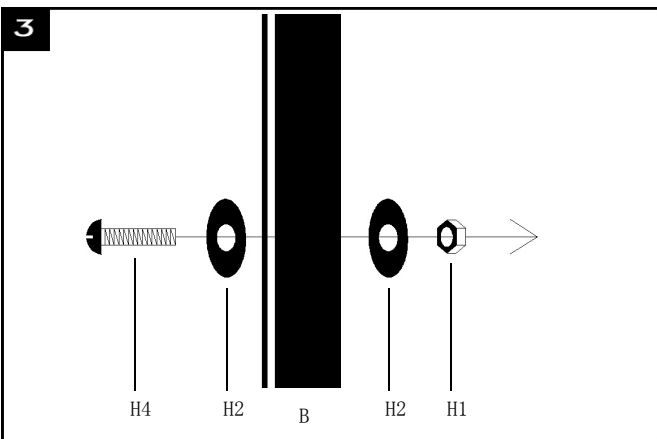

Step 3
The hardware needed to connect the headboard to the bed frame are 4 small bolts (H4), 8 washers (H2), and 4 nuts (H1)

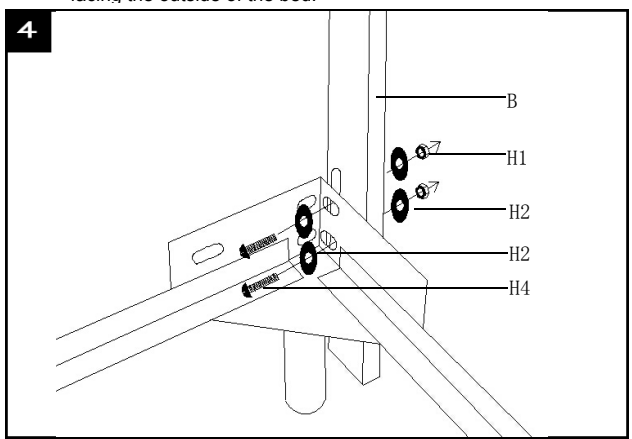

Step 4
Attach the legs of the headboard (B) to the bed frame by fixing them together through the 2 holes in the bed frame and the vertical slot in the leg using 4 small bolts (H4), 8 washers (H2) and 4 nuts (H1)